



February 2, 2017

Reference No. 082715

Ms. Beverly McKeone
Division of Air Quality
WV Department of Environmental Protection
601 57th Street, SE
Charleston, West Virginia 25304

Dear Ms. Beverly McKeone:

**Re: General Permit Registration G70-D Application
Addie Well Pad
Antero Resources Corporation**

GHD Services Inc. (GHD) would like to submit this General Permit Registration application that we prepared on behalf of Antero Resources Corporation for an oil and gas facility identified as Addie Well Pad.

Enclosed are the following documents:

- Original copy of the G70-D General Permit Application.
- Two CD copies of the G70-D General Permit Application.
- The application fee with check no. 468466 in the amount of \$1,500.00.

Please let us know if you have any questions or require additional information.

Sincerely,

GHD Services Inc.

A handwritten signature in black ink, appearing to read "Manuel Bautista", is written over a light blue horizontal line.

Manuel Bautista

MB/ma/293

Encl.

cc: Barry Schatz, Antero Resources Corporation
Elizabeth McLaughlin, Antero Resources Corporation



General Permit G70-D Application

Addie Well Pad

Antero Resources Corporation

GHD | 6320 Rothway Suite 100 Houston Texas 77040
082715 | Report No 293 | January 2017

Table of Contents

G70-D General Permit Application

Attachment A	Single Source Determination Form
Attachment B	Siting Criteria Waiver – Not Applicable
Attachment C	Current Business Certificate
Attachment D	Process Flow Diagram
Attachment E	Process Description
Attachment F	Plot Plan
Attachment G	Area Map
Attachment H	G70-D Section Applicability Form
Attachment I	Emission Units/ERD Table
Attachment J	Fugitive Emissions Summary Sheet
Attachment K	Gas Well Affected Facility Data Sheet
Attachment L	Storage Vessels Data Sheet
Attachment M	Natural Gas Fired Fuel Burning Units Data Sheet
Attachment N	Internal Combustion Engine Data Sheet
Attachment O	Tanker Truck Loading Data Sheet
Attachment P	Glycol Dehydration Unit Sheet(s) – Not Applicable
Attachment Q	Pneumatic Controllers Data Sheet – Not Applicable
Attachment R	Pneumatic Pump Data Sheet – Not Applicable
Attachment S	Air Pollution Control Device/ Emissions Reduction Devices Sheets
Attachment T	Emission Calculations
Attachment U	Facility-wide Emissions Summary Sheets
Attachment V	Class I Legal Advertisement



west virginia department of environmental protection

Division of Air Quality
601 57th Street SE
Charleston, WV 25304
Phone (304) 926-0475
Fax (304) 926-0479
www.dep.wv.gov

G70-D GENERAL PERMIT REGISTRATION APPLICATION

PREVENTION AND CONTROL OF AIR POLLUTION IN REGARD TO THE CONSTRUCTION, MODIFICATION,
RELOCATION, ADMINISTRATIVE UPDATE AND OPERATION OF
NATURAL GAS PRODUCTION FACILITIES LOCATED AT THE WELL SITE

- CONSTRUCTION CLASS I ADMINISTRATIVE UPDATE
MODIFICATION CLASS II ADMINISTRATIVE UPDATE
RELOCATION

SECTION 1. GENERAL INFORMATION

Name of Applicant (as registered with the WV Secretary of State's Office): Antero Resources Corporation

Federal Employer ID No. (FEIN): 80-0162034

Applicant's Mailing Address: 1615 Wynkoop Street

City: Denver

State: CO

ZIP Code: 80202

Facility Name: Addie Well Pad

Operating Site Physical Address: 8 Slaughter Run

City: West Union

Zip Code: 26456

County: Doddridge

Latitude & Longitude Coordinates (NAD83, Decimal Degrees to 5 digits):

Latitude: 39.33352

Longitude: -80.80567

SIC Code: 1311

DAQ Facility ID No. (For existing facilities)

NAICS Code: 21111

CERTIFICATION OF INFORMATION

This G70-D General Permit Registration Application shall be signed below by a Responsible Official. A Responsible Official is a President, Vice President, Secretary, Treasurer, General Partner, General Manager, a member of the Board of Directors, or Owner, depending on business structure. A business may certify an Authorized Representative who shall have authority to bind the Corporation, Partnership, Limited Liability Company, Association, Joint Venture or Sole Proprietorship. Required records of daily throughput, hours of operation and maintenance, general correspondence, compliance certifications and all required notifications must be signed by a Responsible Official or an Authorized Representative. If a business wishes to certify an Authorized Representative, the official agreement below shall be checked off and the appropriate names and signatures entered. Any administratively incomplete or improperly signed or unsigned G70-D Registration Application will be returned to the applicant. Furthermore, if the G70-D forms are not utilized, the application will be returned to the applicant. No substitution of forms is allowed.

I hereby certify that Barry Schatz is an Authorized Representative and in that capacity shall represent the interest of the business (e.g., Corporation, Partnership, Limited Liability Company, Association Joint Venture or Sole Proprietorship) and may obligate and legally bind the business. If the business changes its Authorized Representative, a Responsible Official shall notify the Director of the Division of Air Quality immediately.

I hereby certify that all information contained in this G70-D General Permit Registration Application and any supporting documents appended hereto is, to the best of my knowledge, true, accurate and complete, and that all reasonable efforts have been made to provide the most comprehensive information possible.

Responsible Official Signature:
Name and Title: Phone: Fax:
Email: Date:

If applicable:
Authorized Representative Signature: Barry Schatz
Name and Title: Barry Schatz/ Senior Environmental & Regulatory Manager Phone: 303-357-7276 Fax: 303-357-7315
Email: bschatz@anteroresources.com Date: 1/26/2017

If applicable:
Environmental Contact
Name and Title: Phone: Fax:
Email: Date:

OPERATING SITE INFORMATION

Briefly describe the proposed new operation and/or any change(s) to the facility: New construction of a natural gas and oil production facility.

Directions to the facility: From West Union, Head north on Neely Ave toward Marie St/Old U.S. 50 E and go 36 ft, Turn right at the 1st cross street onto Marie St/Old U.S. 50 E and go 0.2 mi, Turn left onto Davis St and go 0.2 mi, Turn right onto WV-18 N/Sistersville Pike and Continue to follow WV-18 N for 5.5 mi, Slight right onto Slaughter Run Rd and go for 98 ft, Turn right and go 0.2 mi to find the destination on the right.

ATTACHMENTS AND SUPPORTING DOCUMENTS

I have enclosed the following required documents:

Check payable to WVDEP – Division of Air Quality with the appropriate application fee (per 45CSR13 and 45CSR22).

- Check attached to front of application.
- I wish to pay by electronic transfer. Contact for payment (incl. name and email address):
- I wish to pay by credit card. Contact for payment (incl. name and email address):
- \$500 (Construction, Modification, and Relocation) \$300 (Class II Administrative Update)
- \$1,000 NSPS fee for 40 CFR60, Subpart IIII, JJJJ, OOOO and/or OOOOa ¹
- \$2,500 NESHAP fee for 40 CFR63, Subpart ZZZZ and/or HH ²

¹ Only one NSPS fee will apply.

² Only one NESHAP fee will apply. The Subpart ZZZZ NESHAP fee will be waived for new engines that satisfy requirements by complying with NSPS, Subparts IIII and/or JJJJ.

NSPS and NESHAP fees apply to new construction or if the source is being modified.

- Responsible Official or Authorized Representative Signature (if applicable)
- Single Source Determination Form (**must be completed in its entirety**) – Attachment A
- Siting Criteria Waiver (if applicable) – Attachment B Current Business Certificate – Attachment C
- Process Flow Diagram – Attachment D Process Description – Attachment E
- Plot Plan – Attachment F Area Map – Attachment G
- G70-D Section Applicability Form – Attachment H Emission Units/ERD Table – Attachment I
- Fugitive Emissions Summary Sheet – Attachment J
- Gas Well Affected Facility Data Sheet (if applicable) – Attachment K
- Storage Vessel(s) Data Sheet (include gas sample data, USEPA Tanks, simulation software (e.g. ProMax, E&P Tanks, HYSYS, etc.), etc. where applicable) – Attachment L
- Natural Gas Fired Fuel Burning Unit(s) Data Sheet (GPUs, Heater Treaters, In-Line Heaters if applicable) – Attachment M
- Internal Combustion Engine Data Sheet(s) (include manufacturer performance data sheet(s) if applicable) – Attachment N
- Tanker Truck Loading Data Sheet (if applicable) – Attachment O
- Glycol Dehydration Unit Data Sheet(s) (include wet gas analysis, GRI- GLYCalc™ input and output reports and information on reboiler if applicable) – Attachment P
- Pneumatic Controllers Data Sheet – Attachment Q
- Pneumatic Pump Data Sheet – Attachment R
- Air Pollution Control Device/Emission Reduction Device(s) Sheet(s) (include manufacturer performance data sheet(s) if applicable) – Attachment S
- Emission Calculations (please be specific and include all calculation methodologies used) – Attachment T
- Facility-wide Emission Summary Sheet(s) – Attachment U
- Class I Legal Advertisement – Attachment V
- One (1) paper copy and two (2) copies of CD or DVD with pdf copy of application and attachments

GHD SERVICES INC.

▼ PLEASE DETACH AND RETAIN FOR YOUR RECORDS ▼

INVOICE NUMBER	DATE	VOUCHER NO.	AMOUNT
----------------	------	-------------	--------

Account Number:
CR12417

1/24/2017

40WVDEPAQ

401041651

468466

1,500.00

TOTAL: 1,500.00

THIS DOCUMENT IS PROTECTED BY A MICRO-PRINT SIGNATURE LINE, FLUORESCENT PAPER FIBERS, A WATERMARKED BACKER, AND IS REACTIVE TO CHEMICAL ALTERATION

GHD SERVICES INC.

2055 NIAGARA FALLS BLVD, SUITE 3
NIAGARA FALLS, NY 14304

M&T BANK

MANUFACTURERS AND TRADERS TRUST COMPANY
Commercial Banking
Main Office, Ithaca, NY 14850
60-7063-2213

1/24/2017

NO. 468466

PAY

*****1,500

DOLLARS AND

CENTS

*****00

\$*****1,500.00

TO THE
ORDER
OF

**WEST VIRGINIA DEPT OF ENVIRONMENTAL
PROTECTION - DIVISION AIR QUALITY
601 57th Street SE
Charleston, WV 25304 US**

GHD SERVICES INC.

AUTHORIZED SIGNATURES

WARNING: THIS DOCUMENT IS VOID IF ACCOUNT NUMBER DOES NOT APPEAR ON THE REVERSE SIDE IN RED

⑈468466⑈ ⑆221370632⑆61000000118910⑈

Attachment R
AUTHORITY OF CORPORATION
OR OTHER BUSINESS ENTITY (DOMESTIC OR FOREIGN)

TO: The West Virginia Department of Environmental Protection,
Division of Air Quality

DATE: January 23, 2015

ATTN.: Director

Corporation's / other business entity's Federal Employer I.D. Number 80-0162034

The undersigned hereby files with the West Virginia Department of Environmental Protection, Division of Air Quality, a permit application and hereby certifies that the said name is a trade name which is used in the conduct of an incorporated business or other business entity.

Further, the corporation or the business entity certifies as follows:

(1) Barry Schatz (is/are) the authorized representative(s) and in that capacity may represent the interest of the corporation or the business entity and may obligate and legally bind the corporation or the business entity.

(2) The corporation or the business entity is authorized to do business in the State of West Virginia.

(3) If the corporation or the business entity changes its authorized representative(s), the corporation or the business entity shall notify the Director of the West Virginia Department of Environmental Protection, Division of Air Quality, immediately upon such change.



President or Other Authorized Officer
(Vice President, Secretary, Treasurer or other
official in charge of a principal business function of
the corporation or the business entity)

(If not the President, then the corporation or the business entity must submit certified minutes or bylaws stating legal authority of other authorized officer to bind the corporation or the business entity).

Secretary

Name of Corporation or business entity

Attachment A

Single Source Determination Form

ATTACHMENT A - SINGLE SOURCE DETERMINATION FORM

Classifying multiple facilities as one “stationary source” under 45CSR13, 45CSR14, and 45CSR19 is based on the definition of Building, structure, facility, or installation as given in §45-14-2.13 and §45-19-2.12. The definition states:

“Building, Structure, Facility, or Installation” means all of the pollutant-emitting activities which belong to the same industrial grouping, are located on one or more contiguous or adjacent properties, and are under the control of the same person (or persons under common control). Pollutant-emitting activities are a part of the same industrial grouping if they belong to the same “Major Group” (i.e., which have the same two (2)-digit code) as described in the Standard Industrial Classification Manual, 1987 (United States Government Printing Office stock number GPO 1987 0-185-718:QL3).

The Source Determination Rule for the oil and gas industry was published in the Federal Register on June 3, 2016 and will become effective on August 2, 2016. EPA defined the term “adjacent” and stated that equipment and activities in the oil and gas sector that are under common control will be considered part of the same source if they are located on the same site or on sites that share equipment and are within ¼ mile of each other.

Is there equipment and activities in the same industrial grouping (defined by SIC code)?

Yes No

Is there equipment and activities under the control of the same person/people?

Yes No

Is there equipment and activities located on the same site or on sites that share equipment and are within ¼ mile of each other?

Yes No

Addie Well Pad calculation of potential to emit included all of the emission sources that belong to the same industrial grouping, are located on contiguous or adjacent properties, and are under the control of the same person. The nearest emission source that belongs to the same industrial grouping and under the control of the same person but not located on contiguous or adjacent property is the Middle Well Pad. This is approximately 0.69 miles south of the facility.

There is a Compressor Station, identified by name South Canton Compressor Station, located within ¼ mile of the facility. However, the source aggregation does not apply due to the following reasons:

1. They are not directly dependent on each other and belong to the different major industrial group. Addie Pad facility will operate under 1311 SIC code, whereas South Canton Compressor Station belongs to SIC code 4923.
2. The two facilities are not adjacent or contiguous. Antero Midstream LLC or Antero Resources Corporation does not own or manage the area of land between the South Canton Compressor Station and Addie Well Pad.
3. The access roads to South Canton Compressor Station and the Addie Pad will be separate.

Attachment B Siting Criteria Waiver

Attachment B

Siting Waiver

Addie Well Pad

Antero Resources Corporation

Doddridge County, West Virginia

A Siting Waiver form is not required because there are no occupied dwelling structures within 300 feet of Addie Well Pad.

Attachment C

Current Business Certificate

State of West Virginia



Certificate

I, Natalie E. Tennant, Secretary of State of the State of West Virginia, hereby certify that

ANTERO RESOURCES CORPORATION

a corporation formed under the laws of Delaware, which is authorized to transact business in West Virginia by a Certificate of Authority has filed in my office as required by the provisions of the West Virginia Code, a copy of an amendment to its Articles of Incorporation authenticated by the proper office of the state or country of its incorporation and was found to conform to law.

Therefore, I issue this

CERTIFICATE OF AMENDMENT TO CERTIFICATE OF AUTHORITY



*Given under my hand and the
Great Seal of the State of
West Virginia on this day of
June 10, 2013*

Natalie E. Tennant

Secretary of State

FILED

JUN 10 2013

Natalie E. Tennant
Secretary of State
1900 Kanawha Blvd E
Bldg 1, Suite 157-K
Charleston, WV 25305



IN THE OFFICE OF
SECRETARY OF STATE

Penney Barker, Manager
Corporations Division
Tel: (304)558-8000
Fax: (304)558-8381
Website: www.wvsos.com
E-mail: business@wvsos.com

**APPLICATION FOR
AMENDED CERTIFICATE
OF AUTHORITY**

Office Hours: Monday – Friday
8:30 a.m. – 5:00 p.m. ET

FILE ONE ORIGINAL
(Two if you want a filed
stamped copy returned to you)
FEE: \$25.00

**** In accordance with the provisions of the West Virginia Code, the undersigned corporation hereby ****
applies for an Amended Certificate of Authority and submits the following statement:

- Name under which the corporation was authorized to transact business in WV: Antero Resources Appalachian Corporation
- Date Certificate of Authority was issued in West Virginia: 6/25/2008
- Corporate name has been changed to: Antero Resources Corporation
(Attach one Certified Copy of Name Change as filed in home State of Incorporation.)
- Name the corporation elects to use in WV: Antero Resources Corporation
(due to home state name not being available)
- Other amendments: _____
(attach additional pages if necessary)
- Name and phone number of contact person. (This is optional, however, if there is a problem with the filing, listing a contact person and phone number may avoid having to return or reject the document.)
Alvyn A. Schopp (303) 367-7310
Contact Name Phone Number
- Signature Information (See below *Important Legal Notice Regarding Signature*):
Print Name of Signer: Alvyn A. Schopp Title/Capacity: Authorized Person
Signature: Date: June 10, 2013

***Important Legal Notice Regarding Signature:** Per West Virginia Code §31D-1-129. Penalty for signing false document. Any person who signs a document he or she knows is false in any material respect and knows that the document is to be delivered to the secretary of state for filing is guilty of a misdemeanor and, upon conviction thereof, shall be fined not more than one thousand dollars or confined in the county or regional jail not more than one year, or both.

Delaware

PAGE 1

The First State

I, JEFFREY W. BULLOCK, SECRETARY OF STATE OF THE STATE OF DELAWARE, DO HEREBY CERTIFY THE ATTACHED IS A TRUE AND CORRECT COPY OF THE CERTIFICATE OF AMENDMENT OF "ANTERO RESOURCES APPALACHIAN CORPORATION", CHANGING ITS NAME FROM "ANTERO RESOURCES APPALACHIAN CORPORATION" TO "ANTERO RESOURCES CORPORATION", FILED IN THIS OFFICE ON THE TENTH DAY OF JUNE, A.D. 2013, AT 9:37 O'CLOCK A.M.

A FILED COPY OF THIS CERTIFICATE HAS BEEN FORWARDED TO THE NEW CASTLE COUNTY RECORDER OF DEEDS.

4520810 8100

130754186



You may verify this certificate online
at corp.delaware.gov/authver.shtml

Jeffrey W. Bullock, Secretary of State
AUTHENTICATION: 0496546

DATE: 06-10-13

AMENDMENT TO THE
AMENDED AND RESTATED
CERTIFICATE OF INCORPORATION
OF
ANTERO RESOURCES APPALACHIAN CORPORATION

Antero Resources Appalachian Corporation (the "Corporation"), a corporation organized and existing under the laws of the State of Delaware, hereby certifies as follows:

1. The original Certificate of Incorporation of the Corporation was filed under the name Antero Resources Barnett Corporation with the filing of the original Certificate of Incorporation of the Corporation with the Secretary of State of the State of Delaware on March 18, 2008.

2. This Amendment to the Amended and Restated Certificate of Incorporation has been duly adopted and approved in accordance with Sections 242 of the General Corporation Law of the State of Delaware.

3. Article FIRST of the Amended and Restated Certificate of Incorporation is hereby amended to read in its entirety as follows:

FIRST. The name of the Corporation is Antero Resources Corporation.

IN WITNESS WHEREOF, the Corporation has caused this Certificate of Amendment to be executed by its duly authorized officer on the 10th day of June, 2013.

ANTERO RESOURCES APPALACHIAN CORPORATION

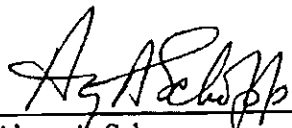
By: 
Name: Alwyn A. Schopp
Title: Vice President of Accounting &
Administration / Treasurer

Attachment D Process Flow Diagram

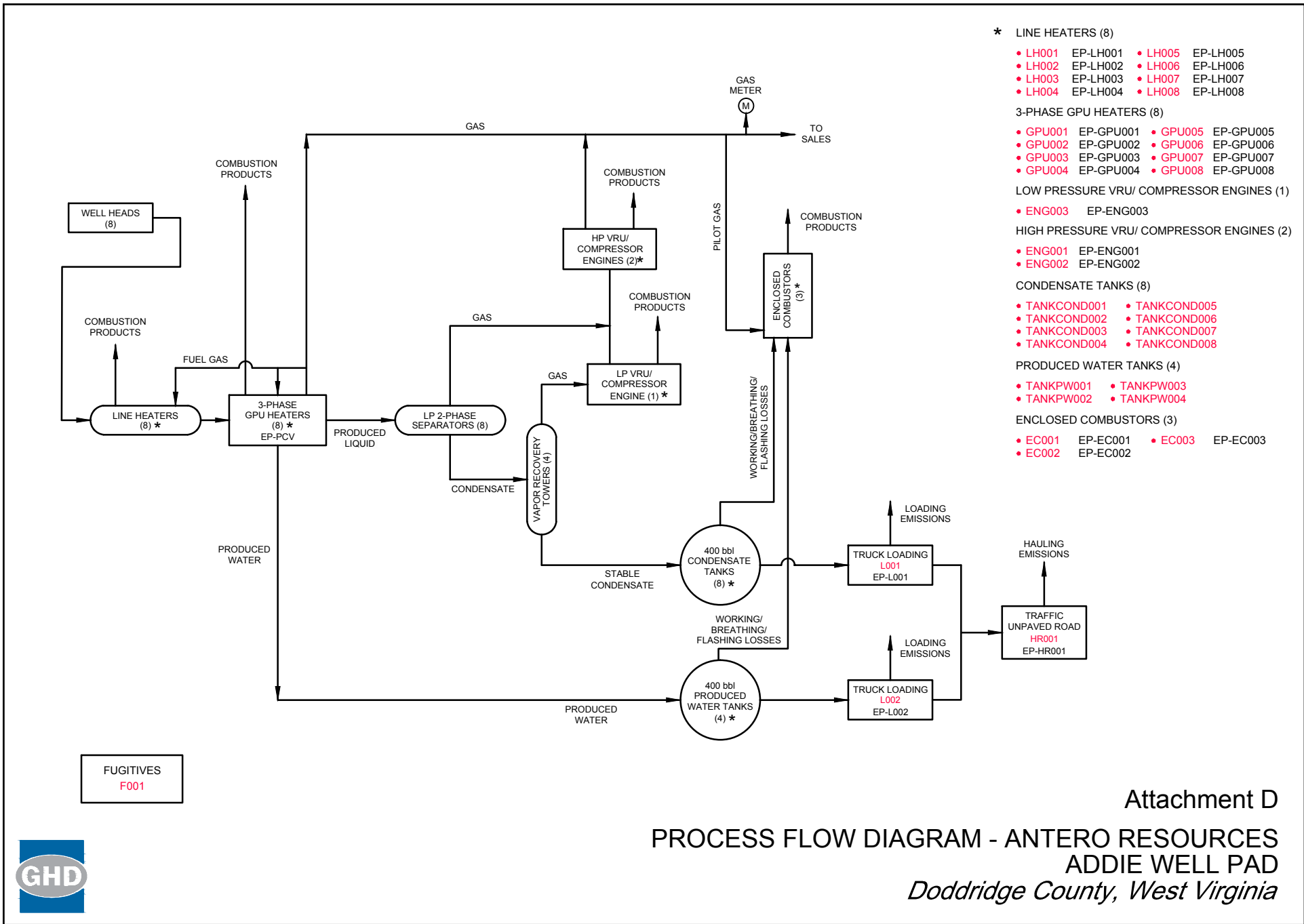

Attachment E Process Description

Attachment E

Process Description

Addie Well Pad

Antero Resources Corporation

Doddridge County, West Virginia

A mixture of condensate, water, and entrained gas from the condensate and gas wells enters the facility through a series of line heaters (LH001-008) and gas production units (GPU001-GPU008). GPUs are 3-phase separators where the gas, condensate, and produced water are separated. The line heaters and GPUs are fueled by a slip stream of the separated gas.

The gas from the three phase separators is metered and sent to the sales gas pipeline. The water flow to the produced water storage tanks (TANKPW001-004). The condensate is then sent to two phase low pressure separators where gas is separated. The gas is routed to the high pressure VRU driven by gas fueled engines (ENG001-002), compressed, metered and sent to the sales gas line. The condensate from the two phase separators then flows to the vapor recovery towers (VRT001-004) where gas is further separated. Gas from the VRTs is recovered via a low pressure VRU driven by gas fueled engine (ENG003), compressed, metered and sent to the sales gas line through the high pressure compressors. The condensate from the VRTs flows to the condensate storage tanks (TANKSCOND001-008). The line heaters are only used during the first several months from start of production and will be removed once production has normalized.

The facility has eight (08) tanks (TANKCOND001-008) on site to store condensate and four (4) tanks (TANKPW001-004) to store produced water prior to removal from the site. The flashing, working and breathing losses from the tanks are routed to three enclosed combustors (EC001-003) to control the emissions. The enclosed combustors that will be used to control emissions are designed to achieve a VOC destruction efficiency of 98 percent.

Condensate and produced water are transported off site on an as needed basis via tanker truck. Truck loading connections are in place to pump condensate (L001) and produced water (L002) from the storage tanks into tanker trucks. Emissions from the loading operations are vented to the atmosphere.

Emissions from the facility's emission sources were calculated using the extended condensate from Central Unit 2H well in Jonathan Davis Well Pad and gas analysis from Hiley Unit 1H well in Diane Davis Well Pad. The extended condensate analysis is considered representative of the materials from Addie Well Pad, being in the same Marcellus rock formation.

Attachment F Plot Plan



GPU001 (EP-GPU001)
 GPU002 (EP-GPU002)
 GPU003 (EP-GPU003)
 GPU004 (EP-GPU004)

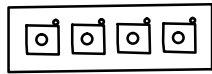

PRODUCTION
EQUIPMENT
(EP-PCV)

HIGH PRESSURE VRU/
COMPRESSOR ENGINE
ENG001 (EP-ENG001)

LOW PRESSURE VRU/
COMPRESSOR ENGINE
ENG003 (EP-ENG003)

HIGH PRESSURE VRU/
COMPRESSOR ENGINE
ENG002 (EP-ENG002)

GPU005 (EP-GPU005)
 GPU006 (EP-GPU006)
 GPU007 (EP-GPU007)
 GPU008 (EP-GPU008)

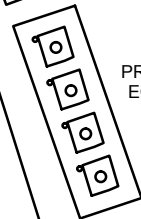

PRODUCTION
EQUIPMENT
(EP-PCV)

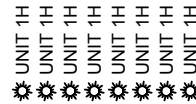

FACILITY
FUGITIVES
F001

HAULING ROUTE
(EP-HR001)
HR001

L001
L002
(EP-L001,
EP-L002)

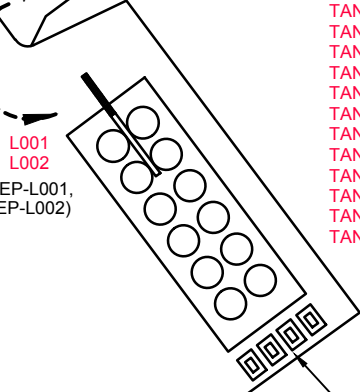

TANKCOND001
TANKCOND002
TANKCOND003
TANKCOND004
TANKCOND006
TANKCOND005
TANKCOND007
TANKCOND008
TANKPW001
TANKPW002
TANKPW003
TANKPW004

VRTs
VRT001
VRT002
VRT003
VRT004

ENCLOSED
COMBUSTORS
EC001 (EP-EC001)
EC002 (EP-EC002)
EC003 (EP-EC003)



Attachment F
 PLOT PLAN
 ADDIE WELL PAD
 ANTERO RESOURCES
 Doddridge County, West Virginia

Attachment G Area Map

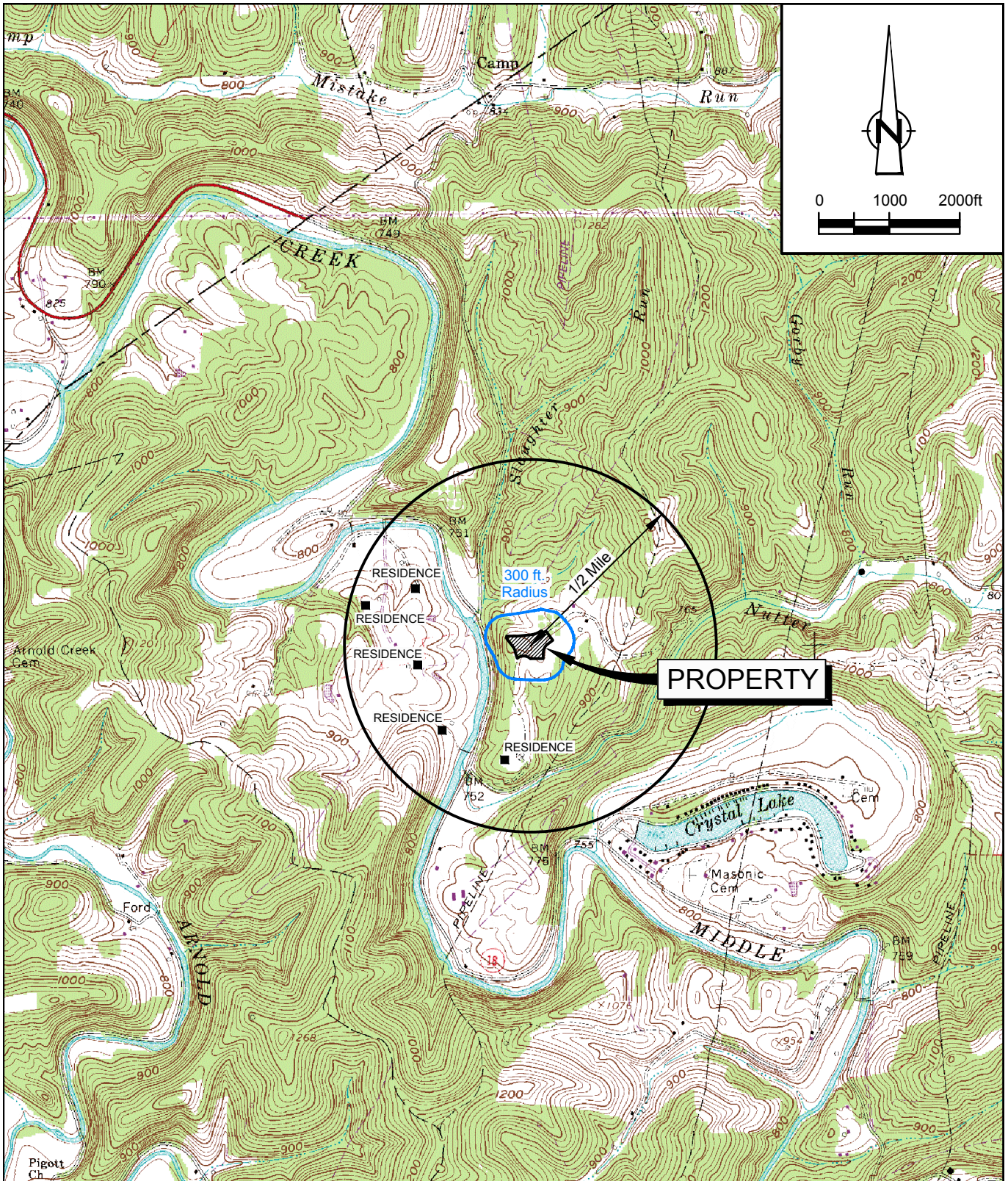

SOURCE: USGS QUADRANGLE MAP;
WEST UNION, WEST VIRGINIA

SITE COORDINATES: LAT. 39.333523, LONG. -80.805677
SITE ELEVATION: 890 ft AMSL



Attachment G
AREA MAP
ADDIE WELL PAD
ANTERO RESOURCES
Doddridge County, West Virginia

Attachment H G70-D Section Applicability Form

ATTACHMENT H – G70-D SECTION APPLICABILITY FORM

**General Permit G70-D Registration¹
Section Applicability Form**

General Permit G70-D was developed to allow qualified applicants to seek registration for a variety of sources. These sources include gas well affected facilities, storage vessels, gas production units, in-line heaters, heater treaters, glycol dehydration units and associated reboilers, pneumatic controllers, centrifugal compressors, reciprocating compressors, reciprocating internal combustion engines (RICES), tank truck loading, fugitive emissions, completion combustion devices, flares, enclosed combustion devices, and vapor recovery systems. All registered facilities will be subject to Sections 1.0, 2.0, 3.0, and 4.0.

General Permit G70-D allows the registrant to choose which sections of the permit they are seeking registration under. Therefore, please mark which additional sections that you are applying for registration under. If the applicant is seeking registration under multiple sections, please select all that apply. Please keep in mind, that if this registration is approved, the issued registration will state which sections will apply to your affected facility.

GENERAL PERMIT G70-D APPLICABLE SECTIONS	
<input checked="" type="checkbox"/> Section 5.0	Gas Well Affected Facility (NSPS, Subpart OOOO/OOOOa)
<input checked="" type="checkbox"/> Section 6.0	Storage Vessels Containing Condensate and/or Produced Water ¹
<input type="checkbox"/> Section 7.0	Storage Vessel Affected Facility (NSPS, Subpart OOOO/OOOOa)
<input checked="" type="checkbox"/> Section 8.0	Control Devices and Emission Reduction Devices not subject to NSPS Subpart OOOO/OOOOa and/or NESHAP Subpart HH
<input checked="" type="checkbox"/> Section 9.0	Small Heaters and Reboilers not subject to 40CFR60 Subpart Dc
<input type="checkbox"/> Section 10.0	Pneumatic Controllers Affected Facility (NSPS, Subpart OOOO/OOOOa)
<input type="checkbox"/> Section 11.0	Pneumatic Pump Affected Facility (NSPS, Subpart OOOOa)
<input checked="" type="checkbox"/> Section 12.0	Fugitive Emissions GHG and VOC Standards (NSPS, Subpart OOOOa)
<input checked="" type="checkbox"/> Section 13.0	Reciprocating Internal Combustion Engines, Generator Engines
<input checked="" type="checkbox"/> Section 14.0	Tanker Truck/Rail Car Loading ²
<input type="checkbox"/> Section 15.0	Glycol Dehydration Units ³

1 Applicants that are subject to Section 6 may also be subject to Section 7 if the applicant is subject to the NSPS, Subparts OOOO or OOOOa control requirements or the applicable control device requirements of Section 8.

2 Applicants that are subject to Section 14 may also be subject to control device and emission reduction device requirements of Section 8.

3 Applicants that are subject to Section 15 may also be subject to the requirements of Section 9 (reboilers). Applicants that are subject to Section 15 may also be subject to control device and emission reduction device requirements of Section 8.

Attachment I Emission Units/ERD Table

ATTACHMENT I – EMISSION UNITS / EMISSION REDUCTION DEVICES (ERD) TABLE

Include ALL emission units and air pollution control devices /ERDs that will be part of this permit application review. This information is required for all sources regardless of whether it is a construction, modification, or administrative update.

Emission Unit ID ¹	Emission Point ID ²	Emission Unit Description	Year Installed	Manufac. Date ³	Design Capacity	Type ⁴ and Date of Change	Control Device(s) ⁵	ERD (s) ⁶
GPU001-008	EP-GPU001-008	Gas Production Unit Heater	2017		1.5 MMBtu/hr	New	N/A	
LH001-008	EP-LH001-008	Line Heater	2017		2.0 MMBtu/hr	New	N/A	
F001	F001	Fugitives	2017		N/A	New	N/A	
TANKCOND001-008	EP-EC001, EP-EC002, EP-EC003	Condensate Tank F/W/B	2017		400 bbl each	New	EC001, EC002, EC003	
TANKPW001-004	EP-EC001, EP-EC002, EP-EC003	PW Tank F/W/B	2017		400 bbl each	New	EC001, EC002, EC003	
L001	EP-L001	Loading (Condensate)	2017		10080 gal/hr 17583510 gal/yr	New	N/A	
L002	EP-L002	Loading (Produced Water)	2017		10080 gal/hr 61320000 gal/yr	New	N/A	
HR001	EP-HR001	Haul Road	2017		Tanker Trucks Condensate: 2094 trips per year Tanker Trucks PW: 7300 trips per year Pick Up Truck: 730 trips per year	New	N/A	
EC001	EP-EC001	Enclosed Combustor	2017		12 MMBtu/hr	New	N/A	
EC002	EP-EC002	Enclosed Combustor	2017		12 MMBtu/hr	New	N/A	
EC003	EP-EC003	Enclosed Combustor	2017		12 MMBtu/hr	New	N/A	
PCV	EP-PCV	Pneumatic CV	2017		6.6 scf/day/PCV	New	N/A	
ENG001-002	EP-ENG001-002	High Pressure VRU Compressor Engine	2017	2015	76 HP	New	Non-Selective Catalytic Reduction	
ENG003	ENG003	Low Pressure VRU Compressor Engine	2017	2015	110 HP	New	Non-Selective Catalytic Reduction	

1 For Emission Units (or Sources) use the following numbering system: 1S, 2S, 3S, ... or other appropriate designation.

2 For Emission Points use the following numbering system: 1E, 2E, 3E, ... or other appropriate designation.

3 When required by rule.

4 New, modification, removal, existing.

5 For Control Devices use the following numbering system: 1C, 2C, 3C, ... or other appropriate designation.

6 For ERDs use the following numbering system: 1D, 2D, 3D, ... or other appropriate designation.

Attachment J

Fugitive Emissions Summary Sheet

ATTACHMENT J – FUGITIVE EMISSIONS SUMMARY SHEET

Sources of fugitive emissions may include loading operations, equipment leaks, blowdown emissions , etc.
Use extra pages for each associated source or equipment if necessary.

Source/Equipment:

Leak Detection Method Used		<input type="checkbox"/> Audible, visual, and olfactory (AVO) inspections		<input checked="" type="checkbox"/> Infrared (FLIR) cameras		<input type="checkbox"/> Other (please describe)		<input type="checkbox"/> None required	
Component Type	Closed Vent System	Count	Source of Leak Factors (EPA, other (specify))	Stream type (gas, liquid, etc.)	Estimated Emissions (tpy)				
					VOC	HAP	GHG (methane)	GHG (CO2e)	
Valves	<input type="checkbox"/> Yes <input checked="" type="checkbox"/> No	400	EPA	gas	2.032	0.268	11.499	287.466	
Valves	<input type="checkbox"/> Yes <input checked="" type="checkbox"/> No	416	EPA	liquid	9.590	1.057	0.132	3.306	
Connections (Not sampling)	<input type="checkbox"/> Yes <input checked="" type="checkbox"/> No	472	EPA	gas	0.107	0.014	0.603	15.076	
Flanges	<input type="checkbox"/> Yes <input checked="" type="checkbox"/> No	104	EPA	gas	0.046	0.006	0.259	6.478	

¹ Other equipment types may include compressor seals, relief valves, diaphragms, drains, meters, etc.

Please provide an explanation of the sources of fugitive emissions (e. g. pigging operations, equipment blowdowns, pneumatic controllers, etc.)

Please indicate if there are any closed vent bypasses (include component)

Specify all equipment used in the closed vent system (e. g. VRU, ERD, thief hatches, tanker truck loading, etc.)

Attachment K

Gas Well Affected Facility Data Sheet

ATTACHMENT K – GAS WELL AFFECTED FACILITY DATA SHEET

Complete this data sheet if you are the owner or operator of a gas well affected facility for which construction, modification or reconstruction commenced after August 23, 2011. This form must be completed for natural gas well affected facilities regardless of when flowback operations occur (or have occurred).

API Number	Date of Flowback	Date of Well Completion	Green Completion and/or Combustion Device	Subject to OOOO or OOOOa?
47-017-06764-00	6/1/2018	1/1/2018	Green	Yes
	6/1/2018	1/1/2018	Green	Yes
	6/1/2018	1/1/2018	Green	Yes
	6/1/2018	1/1/2018	Green	Yes
	6/1/2018	1/1/2018	Green	Yes
	6/1/2018	1/1/2018	Green	Yes
	6/1/2018	1/1/2018	Green	Yes
	6/1/2018	1/1/2018	Green	Yes

Note: If future wells are planned and no API number is available please list as PLANNED.

If there are existing wells that commenced construction prior to August 23, 2011, please acknowledge as existing.

This is the same API (American Petroleum Institute) well number(s) provided in the well completion notification and as provided to the WVDEP, Office of Oil and Gas for the well permit. The API number application without the state code (047).

Every oil and gas well permitted in West Virginia since 1929 has been issued an API number. This API is used by agencies to identify and track oil and gas wells.

The API number has the following format: 047-001-00001

Where,

- 047 = State code. The state code for WV is 047.*
- 001 = County Code. County codes are odd numbers, beginning with 001 (Barbour) and continuing to 109 (Wyoming).*
- 00001 = Well number. Each well will have a unique well number.*

Attachment L

Storage Vessel Data Sheet

ATTACHMENT L – STORAGE VESSEL DATA SHEET

Complete this data sheet if you are the owner or operator of a storage vessel that contains condensate and/or produced water. This form must be completed for each new or modified bulk liquid storage vessel(s) that contains condensate and/or produced water. (If you have more than one (1) identical tank (i.e. 4-400 bbl condensate tanks), then you can list all on one (1) data sheet). **Include gas sample analysis, flashing emissions, working and breathing losses, USEPA Tanks, simulation software (ProMax, E&P Tanks, HYSYS, etc.), and any other supporting documents where applicable.**

The following information is REQUIRED:

- Composition of the representative sample used for the simulation
- For each stream that contributes to flashing emissions:
 - Temperature and pressure (inlet and outlet from separator(s))
 - Simulation-predicted composition
 - Molecular weight
 - Flow rate
- Resulting flash emission factor or flashing emissions from simulation
- Working/breathing loss emissions from tanks and/or loading emissions if simulation is used to quantify those emissions

Additional information may be requested if necessary.

GENERAL INFORMATION (REQUIRED)

1. Bulk Storage Area Name	Tanks	2. Tank Name:	Condensate Tank 001-08
3. Emission Unit ID number:	TANKCOND001-008	4. Emission Point ID number.	EP-EC001, EP-EC002, EP-EC003
5. Date Installed , Modified or Relocated (for existing tanks) 2017	6. Type of change:		
Was the tank manufactured after August 23, 2011 and on or before September 18, 2015? <input type="checkbox"/> Yes <input checked="" type="checkbox"/> No	<input checked="" type="checkbox"/> New construction <input type="checkbox"/> New stored material <input type="checkbox"/> Other <input type="checkbox"/> Relocation		
Was the tank manufactured after September 18, 2015? <input checked="" type="checkbox"/> Yes <input type="checkbox"/> No			
7A. Description of Tank Modification (if applicable)			
7B. Will more than one material be stored in this tank? If so, a separate form must be completed for each material. <input type="checkbox"/> Yes <input checked="" type="checkbox"/> No			
7C. Was USEPA Tanks simulation software utilized? <input type="checkbox"/> Yes <input checked="" type="checkbox"/> No			
<i>If Yes, please provide the appropriate documentation and items 8-42 below are not required.</i>			

TANK INFORMATION

8. Design Capacity (specify barrels or gallons). Use the internal cross-sectional area multiplied by internal height. 400bbbls			
9A. Tank Internal Diameter (ft): 12		9B. Tank Internal Height (or Length) (ft):	20
10A. Maximum Liquid Height (ft): 18		10B. Average Liquid Height (ft):	10
11A. Maximum Vapor Space Height (ft): 18		11B. Average Vapor Space Height (ft):	10
12. Nominal Capacity (specify barrels or gallons). This is also known as "working volume" and considers design liquid levels and overflow valve heights.: 400bbbls			
13A. Maximum annual throughput (gal/yr):	17583510	13B. Maximum daily throughput (gal/day):	48174
14. Number of Turnovers per year (annual net throughput/maximum tank liquid volume):	131	15. Maximum tank fill rate (gal/min)	168
16. Tank fill method <input type="checkbox"/> Submerged <input checked="" type="checkbox"/> Splash <input type="checkbox"/> Bottom Loading			
17. Is the tank system a variable vapor space system? <input type="checkbox"/> Yes <input checked="" type="checkbox"/> No			
If yes, (A) What is the volume expansion capacity of the system (gal)? (B) What are the number of transfers into the system per year?			
18. Type of tank (check all that apply):			
<input checked="" type="checkbox"/> Fixed Roof <input checked="" type="checkbox"/> vertical <input type="checkbox"/> horizontal <input checked="" type="checkbox"/> flat roof <input type="checkbox"/> cone roof <input type="checkbox"/> dome roof <input type="checkbox"/> other (describe)			
<input type="checkbox"/> External Floating Roof <input type="checkbox"/> pontoon roof <input type="checkbox"/> double deck roof			
<input type="checkbox"/> Domed External (or Covered) Floating Roof <input type="checkbox"/> Internal Floating Roof <input type="checkbox"/> vertical column support <input type="checkbox"/> self-supporting			
<input type="checkbox"/> Variable Vapor Space <input type="checkbox"/> lifter roof <input type="checkbox"/> diaphragm <input type="checkbox"/> Pressurized <input type="checkbox"/> spherical <input type="checkbox"/> cylindrical <input type="checkbox"/> other			

ATTACHMENT L – STORAGE VESSEL DATA SHEET

PRESSURE/VACUUM CONTROL DATA

19. Check as many as apply:

Does Not Apply

Inert Gas Blanket of

Vent to Vapor Combustion Device (vapor combustors, flares, thermal oxidizers, enclosed)

Conservation Vent (psig)

Emergency relief Valve (psig) Vacuum Setting Pressure Setting

Thief Hatch Weighted Vacuum Setting Pressure Setting

Yes No

Complete appropriate Air Pollution Control Device Sheet

20. Expected Emission Rate (submit Test Data or Calculations here or elsewhere in the application).

Material Name	Flashing Loss		Breathing Loss		Working Loss		Total Emission Loss		Estimation Method
	lb/hr	tpy	lb/hr	tpy	lb/hr	tpy	lb/hr	tpy	
<i>Please see Table 6 and Table 7</i>									

TANK CONSTRUCTION & OPERATION INFORMATION

21. Tank Shell Construction:

Riveted Gunite lined Epoxy-coated Other (describe): Steel

21A. Shell Color: Green 21B. Roof Color: Green 21C. Year Last Painted 2017

22. Shell Condition (if metal and unlined):

No Rust Light Rust Dense Rust Not applicable

22A. Is the tank heated? 22B. If yes, operating temperature: 22C. If yes, how is heat provided to tank?

Yes No

23. Operating Pressure Range (psig): 0 psig, atmospheric

Must be listed for tanks using VRUs with closed vent system

24. Is the tank a Vertical Fixed Roof Tank? 24A. If yes, for dome roof provide radius (ft): NA 24B. If yes, for cone roof, provide slop (ft/ft): NA

Yes No

25. Complete the following section for **Floating Roof Tanks** Does Not Apply

25A. Year Internal Floaters Installed:

25B. Primary Seal Type: Metallic (mechanical) shoe seal Liquid mounted resilient seal

Vapor mounted resilient seal Other (describe):

25C. Is the Floating Roof equipped with a Secondary Seal? Yes No

25D. If YES, how is the secondary seal mounted? (check one)

Shoe Rim Other (describe)

25E. Is the Floating Roof equipped with a weather shield? Yes No

25F. Describe deck fittings

26. Complete the following section for Internal Floating Roof Tanks Does not apply

26A. Deck Type: Bolted Welded 26B. For bolted decks, provide deck construction

26C. Deck seam:

5 ft. wide 6 ft. wide 7 ft. wide 5 x 7.5 ft wide 5 x 12 ft wide Other (describe)

26D. Deck seam length (ft) 26E. Area of deck (ft²) 26F. For column supported tanks: Number of columns: 26G. For column supported tanks, Diameter of each column:

27. Closed Vent System with VRU Yes No

28. Closed Vent System with Enclosed Combustor? Yes No

ATTACHMENT L – STORAGE VESSEL DATA SHEET

SITE INFORMATION

29. Provide the city and state on which the data in this section are based.: West Union, WV			
30. Daily Average Ambient Temperature (°F):	72.10	31. Annual Average Maximum Temperature (°F):	75.94
32. Annual Average Minimum Temperature (°F):	46.56	33. Average Wind Speed (miles/hr): 18.5 mph	
34. Annual Average Solar Insulation Factor (BTU/(ft ² -day))	1030.236	35. Atmospheric Pressure (psia): 14.8 (based off local conditions, could not find annual)	

LIQUID INFORMATION

36. Average daily temperature range of bulk liquid (F):	72.10	36A. Minimum (°F):	46.56	36B. Maximum (°F)	75.94
37. Average operating pressure range of tank (psig):	atmosphere	37A. Minimum (psig)	0	37B. Maximum (psig)	atmosphere
38A. Minimum Liquid Surface Temperature (°F)	46.56	38B. Corresponding Vapor Pressure (psia)	1.8280		
39A. Average Liquid Surface Temperature (°F)	72.10	39B. Corresponding Vapor Pressure (psia)	3.0683		
40A. Maximum Liquid Surface Temperature (°F)	75.94	40B. Corresponding Vapor Pressure (psia)	3.3028		
41. Provide the following for <u>each</u> liquid or gas to be stored in tank. Add additional pages if necessary.					
41A. Material Name or Composition	Condensate				
41B. CAS Number	mix of HC				
41C. Liquid Density (lb/gal)	5.4900				
41D. Liquid Molecular Weight (lb/lb-mole)	83.00				
41E. Vapor Molecular Weight (lb/lb-mole)	42.6069				
Maximum Vapor Pressure	3.3028				
41F. True (psia)					
41G. Reid (psia)	4.41				
Months Storage per Year	year round				
41H. From - To					
Final maximum gauge pressure and temperature prior to transfer into tank used as inputs into flashing emission calculations	5 psig; 65 F				
42.					

ATTACHMENT L – STORAGE VESSEL DATA SHEET

Complete this data sheet if you are the owner or operator of a storage vessel that contains condensate and/or produced water. This form must be completed for each new or modified bulk liquid storage vessel(s) that contains condensate and/or produced water. (If you have more than one (1) identical tank (i.e. 4-400 bbl condensate tanks), then you can list all on one (1) data sheet). **Include gas sample analysis, flashing emissions, working and breathing losses, USEPA Tanks, simulation software (ProMax, E&P Tanks, HYSYS, etc.), and any other supporting documents where applicable.**

The following information is **REQUIRED**:

- Composition of the representative sample used for the simulation
- For each stream that contributes to flashing emissions:
 - Temperature and pressure (inlet and outlet from separator(s))
 - Simulation-predicted composition
 - Molecular weight
 - Flow rate
- Resulting flash emission factor or flashing emissions from simulation
- Working/breathing loss emissions from tanks and/or loading emissions if simulation is used to quantify those emissions

Additional information may be requested if necessary.

GENERAL INFORMATION (REQUIRED)

1. Bulk Storage Area Name Tanks	2. Tank Name: Produced Water Tank 001-004
3. Emission Unit ID number: TANKPW001-004	4. Emission Point ID number. EP-EC001, EP-EC002, EP-EC003
5. Date Installed, Modified or Relocated (for existing tanks) 2016	6. Type of change: <input checked="" type="checkbox"/> New construction <input type="checkbox"/> New stored material <input type="checkbox"/> Other <input type="checkbox"/> Relocation
Was the tank manufactured after August 23, 2011 and on or before September 18, 2015? <input type="checkbox"/> Yes <input checked="" type="checkbox"/> No	
Was the tank manufactured after September 18, 2015? <input checked="" type="checkbox"/> Yes <input type="checkbox"/> No	
7A. Description of Tank Modification (if applicable)	
7B. Will more than one material be stored in this tank? If so, a separate form must be completed for each material. <input type="checkbox"/> Yes <input checked="" type="checkbox"/> No	
7C. Was USEPA Tanks simulation software utilized? <input type="checkbox"/> Yes <input checked="" type="checkbox"/> No	

If Yes, please provide the appropriate documentation and items 8-42 below are not required.

TANK INFORMATION

8. Design Capacity (specify barrels or gallons). Use the internal cross-sectional area multiplied by internal height. 400bbbls			
9A. Tank Internal Diameter (ft): 12	9B. Tank Internal Height (or Length) (ft):		20
10A. Maximum Liquid Height (ft): 18	10B. Average Liquid Height (ft):		10
11A. Maximum Vapor Space Height (ft): 18	11B. Average Vapor Space Height (ft):		10
12. Nominal Capacity (specify barrels or gallons). This is also known as "working volume" and considers design liquid levels and overflow valve heights.: 400bbbls			
13A. Maximum annual throughput (gal/yr):	61320000	13B. Maximum daily throughput (gal/day):	168000
14. Number of Turnovers per year (annual net throughput/maximum tank liquid volume):	913	15. Maximum tank fill rate (gal/min)	168
16. Tank fill method <input type="checkbox"/> Submerged <input checked="" type="checkbox"/> Splash <input type="checkbox"/> Bottom Loading			
17. Is the tank system a variable vapor space system? <input type="checkbox"/> Yes <input checked="" type="checkbox"/> No			
If yes, (A) What is the volume expansion capacity of the system (gal)? (B) What are the number of transfers into the system per year?			
18. Type of tank (check all that apply): <input checked="" type="checkbox"/> Fixed Roof <input checked="" type="checkbox"/> vertical <input type="checkbox"/> horizontal <input checked="" type="checkbox"/> flat roof <input type="checkbox"/> cone roof <input type="checkbox"/> dome roof <input type="checkbox"/> other (describe) <input type="checkbox"/> External Floating Roof <input type="checkbox"/> pontoon roof <input type="checkbox"/> double deck roof <input type="checkbox"/> Domed External (or Covered) Floating Roof <input type="checkbox"/> Internal Floating Roof <input type="checkbox"/> vertical column support <input type="checkbox"/> self-supporting <input type="checkbox"/> Variable Vapor Space <input type="checkbox"/> lifter roof <input type="checkbox"/> diaphragm <input type="checkbox"/> Pressurized <input type="checkbox"/> spherical <input type="checkbox"/> cylindrical			

ATTACHMENT L – STORAGE VESSEL DATA SHEET

SITE INFORMATION

29. Provide the city and state on which the data in this section are based.: West Union, WV			
30. Daily Average Ambient Temperature (°F):	72.10	31. Annual Average Maximum Temperature (°F):	75.94
32. Annual Average Minimum Temperature (°F):	46.56	33. Average Wind Speed (miles/hr): 5.9 mph	
34. Annual Average Solar Insulation Factor (BTU/(ft ² -day))	1030.235999	35. Atmospheric Pressure (psia): 14.8 (based off local conditions, could not find annual)	

LIQUID INFORMATION

36. Average daily temperature range of bulk liquid (F):	72.10	36A. Minimum (°F):	46.56	36B. Maximum (°F)	75.94
37. Average operating pressure range of tank (psig):	atmosphere	37A. Minimum (psig)	0	37B. Maximum (psig)	atmosphere
38A. Minimum Liquid Surface Temperature (°F)	46.56	38B. Corresponding Vapor Pressure (psia)	0.2282		
39A. Average Liquid Surface Temperature (°F)	72.10	39B. Corresponding Vapor Pressure (psia)	0.4528		
40A. Maximum Liquid Surface Temperature (°F)	75.94	40B. Corresponding Vapor Pressure (psia)	0.4991		

41. Provide the following for each liquid or gas to be stored in tank. Add additional pages if necessary.

41A. Material Name or Composition	Produced Water		
41B. CAS Number	mix of HC and water		
41C. Liquid Density (lb/gal)	8.3300		
41D. Liquid Molecular Weight (lb/lb-mole)	18.56		
41E. Vapor Molecular Weight (lb/lb-mole)	18.5618		
Maximum Vapor Pressure	0.4991		
41F. True (psia)			
41G. Reid (psia)	1.0339		
Months Storage per Year	year round		
41H. From - To			
Final maximum gauge pressure and temperature prior to transfer into tank used as inputs into flashing emission calculations	238 psig; 70 F		
42.			

Attachment M
Natural Gas Fired Fuel Burning Unit(s)
Data Sheet

**ATTACHMENT M – SMALL HEATERS AND REBOILERS NOT SUBJECT TO
40CFR60 SUBPART DC
DATA SHEET**

Complete this data sheet for each small heater and reboiler not subject to 40CFR60 Subpart Dc at the facility. *The Maximum Design Heat Input (MDHI) must be less than 10 MMBTU/hr.*

Emission Unit ID#	Emission Point ID#	Emission Unit Description (Manufacturer, model#)	Year Installed/Modified	Type and Date of Change	Maximum Design Heat Input (MMBTU/hr)	Fuel Heating Value (BTU/scf)
GPU001	EP-GPU001	Gas Production Unit Heater	2017	New	1.5	1206.8951
GPU002	EP-GPU002	Gas Production Unit Heater	2017	New	1.5	1206.8951
GPU003	EP-GPU003	Gas Production Unit Heater	2017	New	1.5	1206.8951
GPU004	EP-GPU004	Gas Production Unit Heater	2017	New	1.5	1206.8951
GPU005	EP-GPU005	Gas Production Unit Heater	2017	New	1.5	1206.8951
GPU006	EP-GPU006	Gas Production Unit Heater	2017	New	1.5	1206.8951
GPU007	EP-GPU007	Gas Production Unit Heater	2017	New	1.5	1206.8951
GPU008	EP-GPU008	Gas Production Unit Heater	2017	New	1.5	1206.8951
LH001	EP-LH001	Line Heater	2017	New	2	1206.8951
LH002	EP-LH002	Line Heater	2017	New	2	1206.8951
LH003	EP-LH003	Line Heater	2017	New	2	1206.8951
LH004	EP-LH004	Line Heater	2017	New	2	1206.8951
LH005	EP-LH005	Line Heater	2017	New	2	1206.8951
LH006	EP-LH006	Line Heater	2017	New	2	1206.8951
LH007	EP-LH007	Line Heater	2017	New	2	1206.8951
LH008	EP-LH008	Line Heater	2017	New	2	1206.8951

1. Enter the appropriate Emission Unit (or Source) identification number for each fuel burning unit located at the production pad. Gas Producing Unit Burners should be designated GPU-1, GPU-2, etc. Heater Treaters should be designated HT-1, HT-2, etc. Heaters or Line Heaters should be designated LH-1, LH-2, etc. For sources, use 1S, 2S, 3S...or other appropriate designation. Enter glycol dehydration unit Reboiler Vent data on the Glycol Dehydration Unit Data Sheet.

2. Enter the appropriate Emission Point identification numbers for each fuel burning unit located at the production pad. Gas Producing Unit Burners should be designated GPU-1, GPU-2, etc. Heater Treaters should be designated HT-1, HT-2, etc. Heaters or Line Heaters should be designated LH-1, LH-2, etc. For emission points, use 1E, 2E, 3E...or other appropriate designation.

3. New, modification, removal.

4. Enter design heat input capacity in MMBtu/hr.

5. Enter the fuel heating value in BTU/standard cubic foot.

Attachment N

Internal Combustion Engine Data Sheet

ATTACHMENT N – INTERNAL COMBUSTION ENGINE DATA SHEET

Complete this data sheet for each internal combustion engine at the facility. Include manufacturer performance data sheet(s) or any other supporting document if applicable. Use extra pages if necessary. *Generator(s) and microturbine generator(s) shall also use this form.*

Emission Unit ID#		ENG001-002		ENG003			
Engine Manufacturer/Model		Ford MSG425 2.5L Engine		Ford CSG-637 3.7L Engine			
Manufacturers Rated bhp/rpm		76 HP @ 3200 rpm		110 HP @ 3200 rpm			
Source Status		NS		NS			
Date Installed/ Modified/ Removed/ Relocated		2017		2017			
Engine Manufacturer/ Reconstruction Date		2015		2015			
Check all applicable Federal Rules for the engine (include EPA Certification of Conformity if applicable)		<input checked="" type="checkbox"/> 40CFR60 Subpart JJJJ <input checked="" type="checkbox"/> JJJJ Certified? <input type="checkbox"/> 40CFR60 Subpart IIII <input type="checkbox"/> IIII Certified? <input checked="" type="checkbox"/> 40CFR63 Subpart ZZZZ <input type="checkbox"/> NESHAP ZZZZ/NSPS JJJJ Window <input type="checkbox"/> NESHAP ZZZZ Remote Sources		<input checked="" type="checkbox"/> 40CFR60 Subpart JJJJ <input checked="" type="checkbox"/> JJJJ Certified? <input type="checkbox"/> 40CFR60 Subpart IIII <input type="checkbox"/> IIII Certified? <input checked="" type="checkbox"/> 40CFR63 Subpart ZZZZ <input type="checkbox"/> NESHAP ZZZZ/NSPS JJJJ Window <input type="checkbox"/> NESHAP ZZZZ Remote Sources		<input type="checkbox"/> 40CFR60 Subpart JJJJ <input type="checkbox"/> JJJJ Certified? <input type="checkbox"/> 40CFR60 Subpart IIII <input type="checkbox"/> IIII Certified? <input type="checkbox"/> 40CFR63 Subpart ZZZZ <input type="checkbox"/> NESHAP ZZZZ/NSPS JJJJ Window <input type="checkbox"/> NESHAP ZZZZ Remote Sources	
Engine Type		4SRB		4SRB			
APCD Type		NSCR		NSCR			
Fuel Type		RG		RG			
H2S (gr/ 100 scf)		0		0			
Operating bhp/rpm		50 HP @ 2300 rpm		77 HP @ 2200 rpm			
BSFC (BTU/bhp-hr)		8328		7724			
Hourly Fuel Throughput (Must use 8,760 hrs/yr unless emergency generator)		345.00 ft ³ /hr gal/hr		435.20 ft ³ /hr gal/hr		ft ³ /hr gal/hr	
Fuel Usage or Hours of Operation Metered		3.022 MMft ³ /yr gal/yr		3.812352 MMft ³ /yr gal/yr		MMft ³ /yr gal/yr	
Calculation Methodology	Pollutant	Hourly PTE (lb/hr)	Annual PTE (tons/year)	Hourly PTE (lb/hr)	Annual PTE (tons/year)	Hourly PTE (lb/hr)	Annual PTE (tons/year)
MD	NOx	0.1250	0.5477	0.0724	0.3171		
MD	CO	0.8253	3.6146	0.5972	2.6158		
AP	VOC	0.0375	0.1641	0.0251	0.1102		
AP	SO2	0.0007	0.0033	0.0005	0.0022		
AP	PM10	0.0120	0.0527	0.0081	0.0354		
AP	Formaldehyde	0.0259	0.1137	0.0174	0.0763		
AP	Total HAPs	0.0291	0.1273	0.0195	0.0854		
OT	GHG (CO2e)	146.5154	641.7373	98.3475	430.7619		

Installation Drawings

Front End View

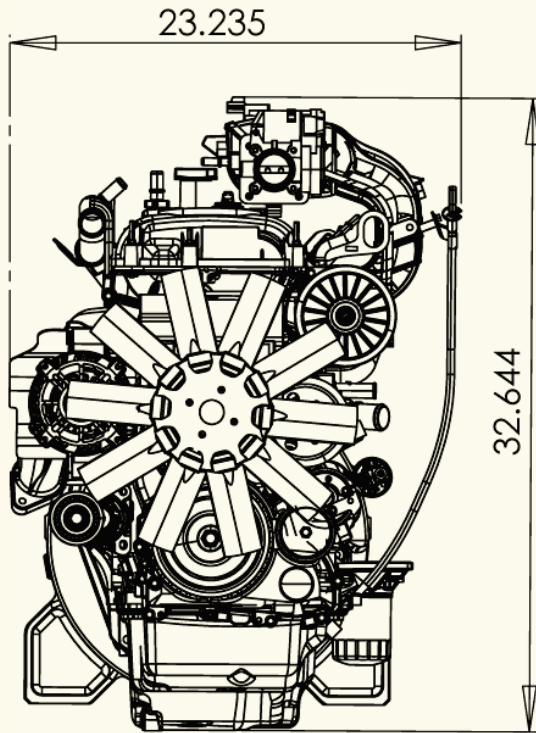

Left Side View

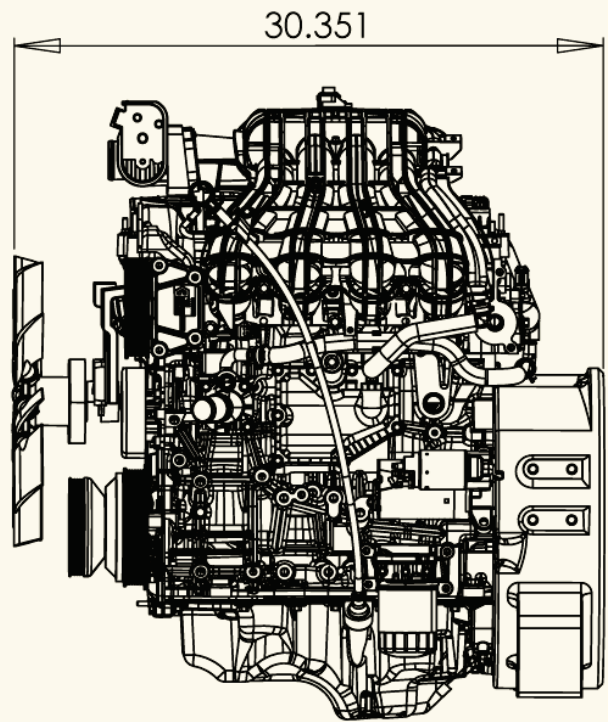

Power Curves (corrected per SAE J1349)

Gasoline

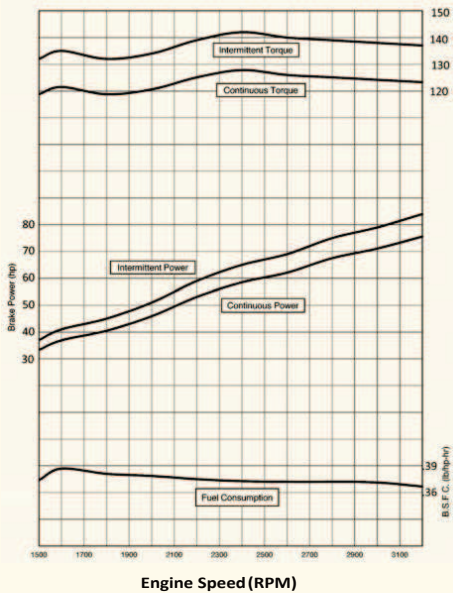

Natural Gas

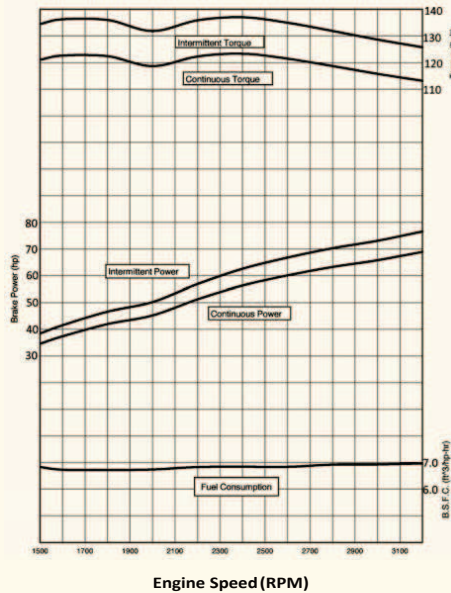

Liquefied Petroleum Gas

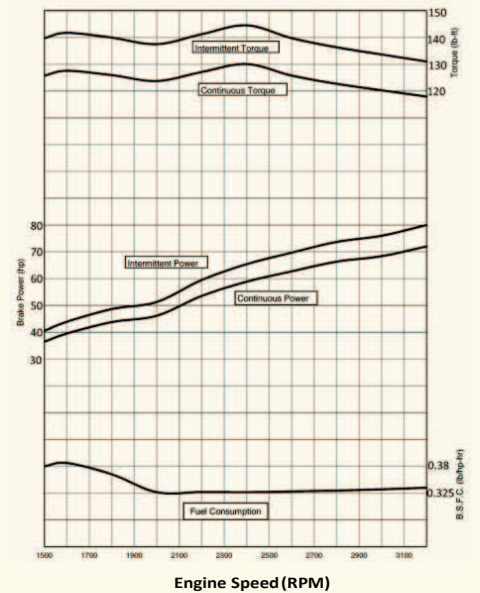

Powertrain Assemblies
& Components
Provided By Ford
Component Sales

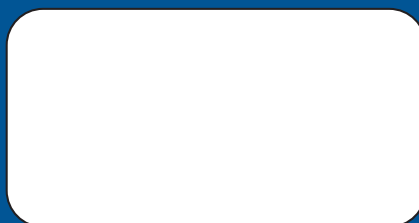

MSG-425^{EFI}

2.5 Liter 4-Cylinder



Options

Engine Cooling Fans

- 15" (381mm) diameter suction
- 15" (381mm) diameter pusher

Flywheels

- 10" (254mm) SAE over-center clutch
- flat face flywheel

Flywheel Housings

- SAE #4

Exhaust Manifold

- rear dump down

Power Steering Pump

Wiring Harnesses

Discrete Speed Switch

Variable Speed Hand Throttle

Variable Speed Foot Pedal

Engine Mounts

- Automotive with insulators
- Open power unit

Electronic Instrument Panel, Gauges

Three Way Catalyst / Muffler Standard

Transmissions

6R80 electronic shift

C6 Mechanical

Emissions Information

California Air Resources Board (CARB)

Environmental Protection Agency (EPA)

Emission Certified Packages Available.

Warranty

Contact Engine Distributors, Inc
for warranty details.



Powertrain Assemblies
& Components
Provided By Ford
Component Sales

Specifications

Engine Type	I-4
Bore and Stroke	3.5"x3.93" (89mmx100mm)
Displacement	2.5L Liter (152.5 CID)
Compression Ratio.....	9.7:1
Oil Capacity.....	7 qts. including filter
Net Weight	351 Lbs. with accessories (159 Kgs.)
Dimensions	L 30.3" x W 23.3" x H 32.6" (769 mm x 589 mm x 828 mm)

GASOLINE (corrected per SAE J1349)

Unleaded 87 or 89 octane		
Intermittent Power	84 [HP] @ 3200rpm	(62 [kW] @ 3200rpm)
Continuous power	75 [HP] @ 3200rpm	(56 [kW] @ 3200rpm)
Intermittent Torque	137 [ft-lbs] @ 3200rpm	(185 [N-m] @ 3200rpm)
Continuous Torque	123 [ft-lbs] @ 3200rpm	(166 [N-m] @ 3200rpm)

NATURAL GAS (corrected per SAE J1349)

Fuel Specification	1050 BTU/FT3	
Intermittent Power	76 [HP] @ 3200rpm	(56 [kW] @ 3200rpm)
Continuous power	68 [HP] @ 3200rpm	(50 [kW] @ 3200rpm)
Intermittent Torque	125 [ft-lbs] @ 3200rpm	(169 [N-m] @ 3200rpm)
Continuous Torque	113 [ft-lbs] @ 3200rpm	(153 [N-m] @ 3200rpm)

LIQUEFIED PETROLEUM GAS (corrected per SAE J1349)

Fuel Specification	HD-5	
Intermittent Power	80 [HP] @ 3200rpm	(59 [kW] @ 3200rpm)
Continuous power	72 [HP] @ 3200rpm	(53 [kW] @ 3200rpm)
Intermittent Torque	131 [ft-lbs] @ 3200rpm	(177 [N-m] @ 3200rpm)
Continuous Torque	118 [ft-lbs] @ 3200rpm	(160 [N-m] @ 3200rpm)

Standard Features / Benefits

Set-for-life valvetrain

Deep skirted, ribbed cylinder block casting for rigidity

Aluminum AA319 cylinder block cast with the Cosworth process,
including cast-in-place iron cylinder liners.

Chain driven dual camshafts with automatic tensioning system

Structural front cover and oil pan

Alternate fuel ready valvetrain components

Individual coil on plug electronic ignition

Cast aluminum camshaft cover to ensure warp-free sealing

Sintered metal connecting rods

Nodular iron crankshaft, featuring five main bearings,
eight counterweights

Broadband knock sensor, calibrated for individual cylinder use

Gasoline Sequential Port Fuel Injection

Closed loop fuel control for all fuels

Electronic engine management system with built-in engine
protection against detonation, high coolant temperature, low oil
pressure, over speed shutdown and starter lockout

Next generation governing - discrete speeds, variable speeds,
drive by wire - using the highest quality components.

Pursuant to the authority vested in the Air Resources Board by the Health and Safety Code, Division 26, Part 5, Chapters 1 and 2; and

Pursuant to the authority vested in the undersigned by Health and Safety Code Sections 39515 and 39516 and Executive Order G-14-012;

IT IS ORDERED AND RESOLVED: That the following new large spark-ignition engines and emission control systems produced by the manufacturer are certified for use in off-road equipment as described below. Production engines shall be in all material respects the same as those for which certification is granted.

MODEL YEAR	ENGINE FAMILY NAME	ENGINE DISPLACEMENT (liters)	FUEL TYPE
2015	FEDIB02.5MSG	2.5	Gasoline, LPG, CNG, Gasoline-LPG Dual Fuel
DURABILITY HOURS	SPECIAL FEATURES & EMISSION CONTROL SYSTEMS		TYPICAL EQUIPMENT USAGE
5000	Three-Way Catalytic Converter, Heated Oxygen Sensor, Sequential Multiport Fuel Injection (Gas), Gaseous Fuel Mixer (LPG, CNG)		Forklift, Aerial Lift, Generator, Compressor, Pump, Other Industrial Equipment
ENGINE MODELS (rated power in kilowatt, kW)		MSG425-DF (64.3 kW), MSG425-GAS (64.3 kW), MSG425-LPG (59.8 kW), MSG425-LP VAPOR (59.8 kW), MSG425-NG (57.3 kW)	

The following are the hydrocarbon plus oxides of nitrogen (HC+NOx) and carbon monoxide (CO) exhaust certification emission standards (Title 13, California Code of Regulations, (13 CCR) Section 2433(b)(1)) and certification emission levels for this engine family in grams per kilowatt-hour (g/kW-hr). Engines within this engine family shall have closed crankcases in conformance with 13 CCR Section 2433(b)(3).

(g/kW-hr)	HC+NOx	CO
Exhaust Standards	0.8	20.6
Certification Levels	0.5	3.3

The following is the evaporative hydrocarbon emission standard (13 CCR Section 2433(b)(4)) and certification emission level for this engine family in grams per gallon of fuel tank capacity (g/gallon).

Evaporative Certification Method	HC Certification Level (g/gallon)	HC Certification Standard (g/gallon)
Design Based	N/A	0.2

BE IT FURTHER RESOLVED: That for the listed engines for the aforementioned model-year, the manufacturer has submitted, and the Executive Officer hereby approves, the information and materials to demonstrate certification compliance with 13 CCR Section 2433(c) (certification and test procedures), 13 CCR Section 2434 (emission control labels), and 13 CCR Sections 2435 and 2436 (emission control system warranty).

Engines certified under this Executive Order must conform to all applicable California emission regulations.

This Executive Order is only granted to the engine family and model-year listed above. Engines in this family that are produced for any other model-year are not covered by this Executive Order.

Executed at El Monte, California on this 14th day of November 2014.

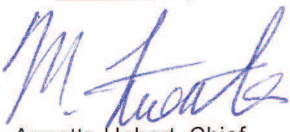
 Annette Hebert, Chief
 Emissions Compliance, Automotive Regulations and Science Division



**UNITED STATES ENVIRONMENTAL PROTECTION AGENCY
2015 MODEL YEAR
CERTIFICATE OF CONFORMITY
WITH THE CLEAN AIR ACT**

**OFFICE OF TRANSPORTATION
AND AIR QUALITY
ANN ARBOR, MICHIGAN 48105**

Certificate Issued To: Engine Distributors, Inc.
(U.S. Manufacturer or Importer)
Certificate Number: FEDIB02.5MSG-002

Effective Date:
12/09/2014

Expiration Date:
12/31/2015

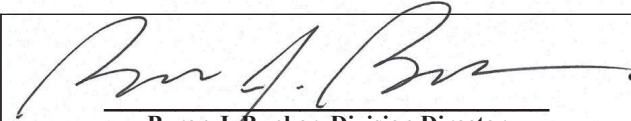
Byron J. Bunker, Division Director
Compliance Division

Issue Date:
12/09/2014

Revision Date:
N/A

Manufacturer: Engine Distributors, Inc.
Engine Family: FEDIB02.5MSG
Certification Type: Mobile and Stationary
Fuel : LPG/Propane
Gasoline (up to and including 10% Ethanol)
Natural Gas (CNG/LNG)
Emission Standards : NMHC + NOx (g/kW-hr) : 0.8
HC + NOx (g/kW-hr) : 0.8
CO (g/kW-hr) : 20.6
NMHC + NOx (g/kW-hr) : 0.8
HC + NOx (g/kW-hr) : 0.8
CO (g/kW-hr) : 20.6
Emergency Use Only : N

Pursuant to Section 213 of the Clean Air Act (42 U.S.C. section 7547) and 40 CFR Part 60, 40 CFR Part 1048, 1065, 1068, and 60 (stationary only and combined stationary and mobile) and subject to the terms and conditions prescribed in those provisions, this certificate of conformity is hereby issued with respect to the test engines which have been found to conform to applicable requirements and which represent the following nonroad engines, by engine family, more fully described in the documentation required by 40 CFR Part 60, 40 CFR Part 1048 and produced in the stated model year.

This certificate of conformity covers only those new nonroad spark-ignition engines which conform in all material respects to the design specifications that applied to those engines described in the documentation required by 40 CFR Part 60, 40 CFR Part 1048 and which are produced during the model year stated on this certificate of the said manufacturer, as defined in 40 CFR Part 60, 40 CFR Part 1048. This certificate of conformity does not cover nonroad engines imported prior to the effective date of the certificate.

It is a term of this certificate that the manufacturer shall consent to all inspections described in 40 CFR 1068.20 and authorized in a warrant or court order. Failure to comply with the requirements of such a warrant or court order may lead to revocation or suspension of this certificate for reasons specified in 40 CFR Part 60, 40 CFR Part 1048. It is also a term of this certificate that this certificate may be revoked or suspended or rendered void *ab initio* for other reasons specified in 40 CFR Part 60, 40 CFR Part 1048.

This certificate does not cover large nonroad engines sold, offered for sale, or introduced, or delivered for introduction, into commerce in the U.S. prior to the effective date of the certificate.

Gasoline

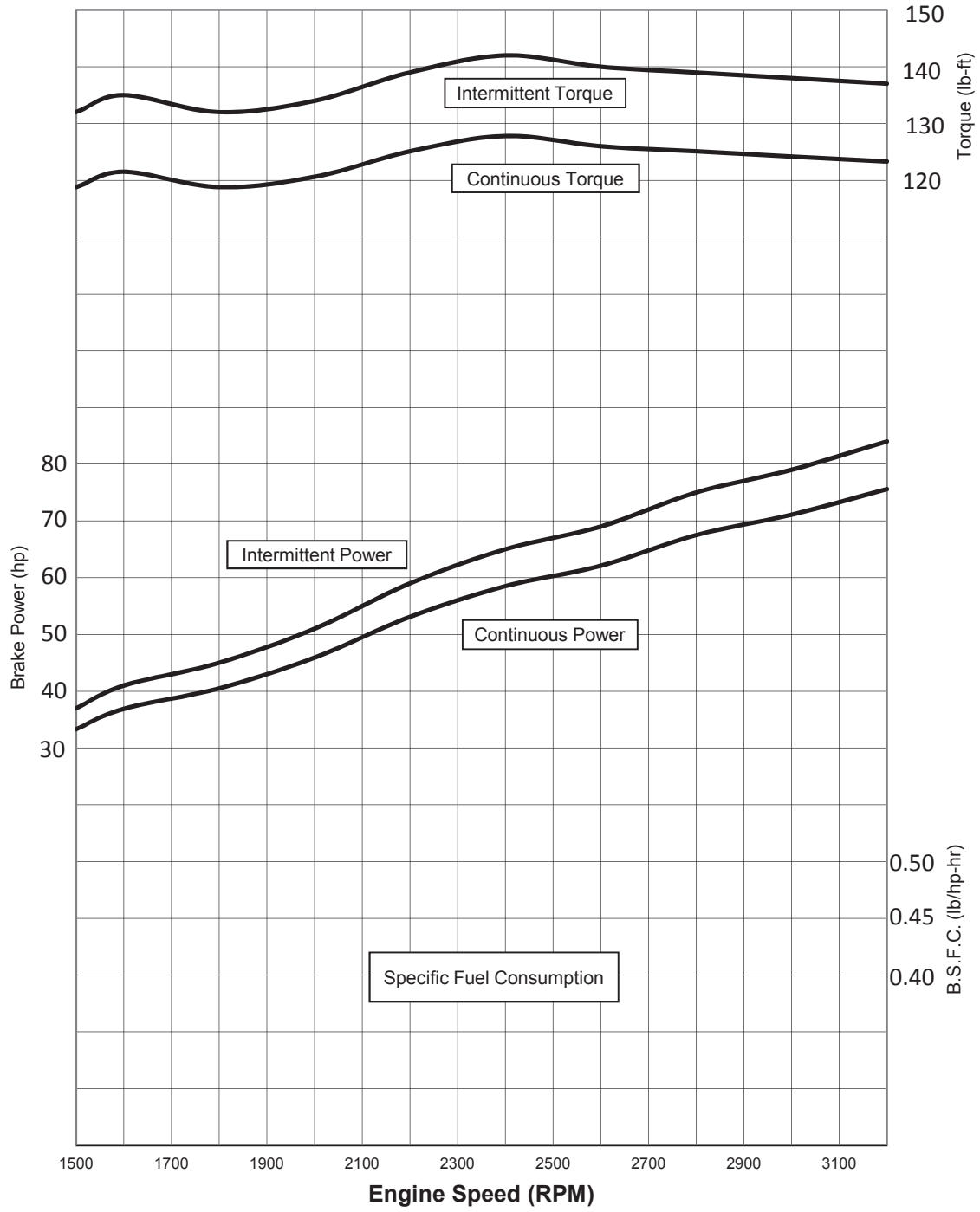

LP

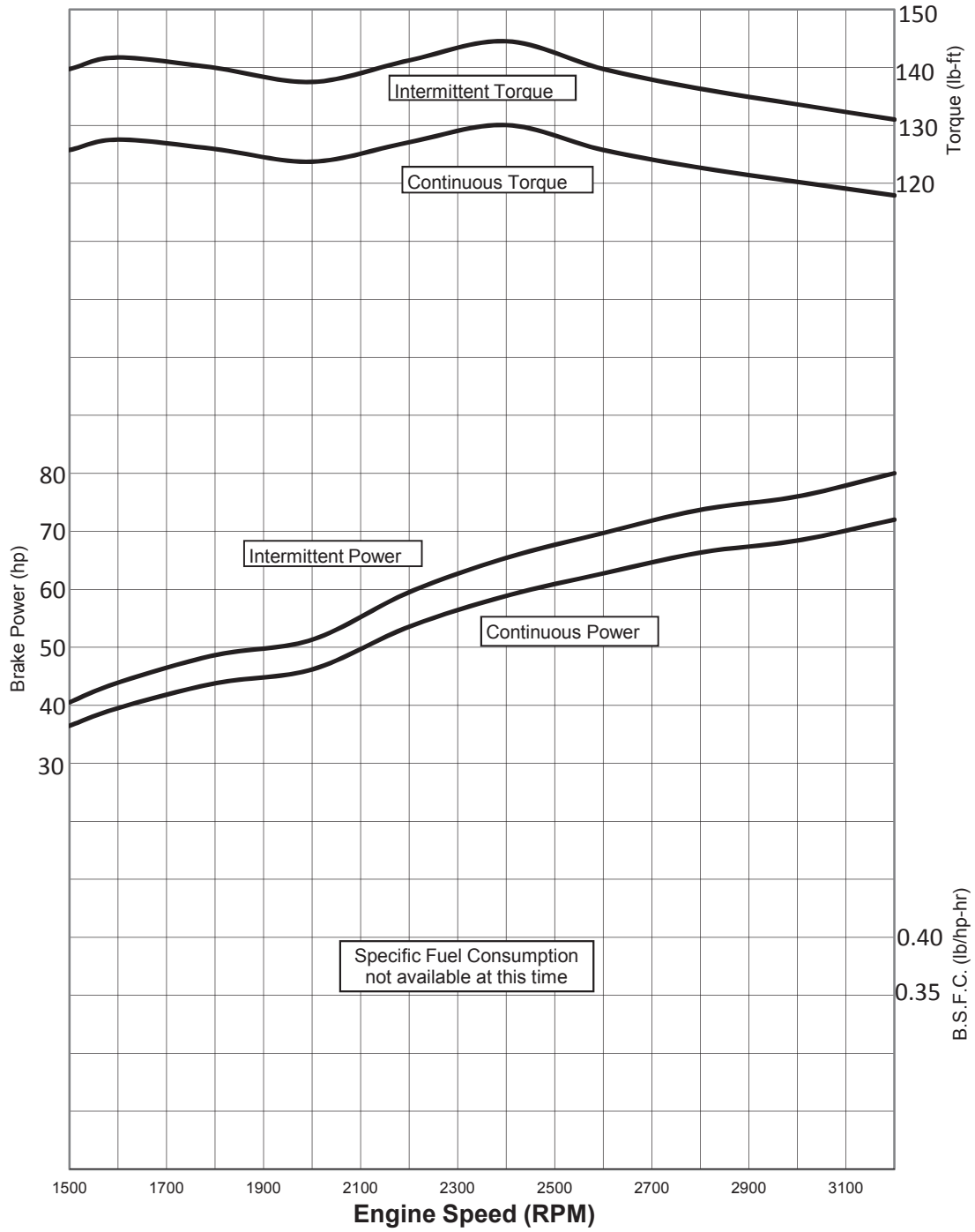

NG

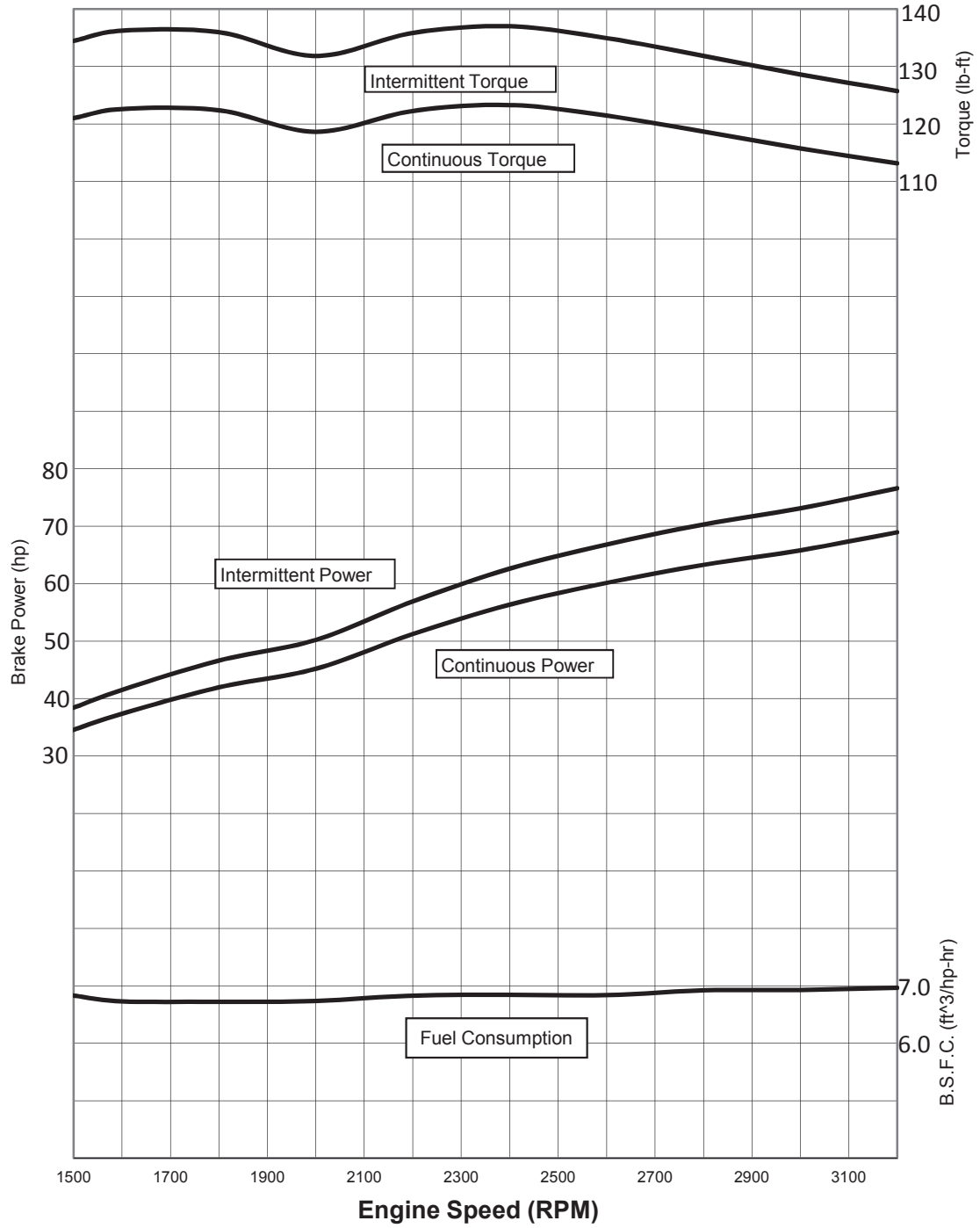

Installation Drawings

Front End View

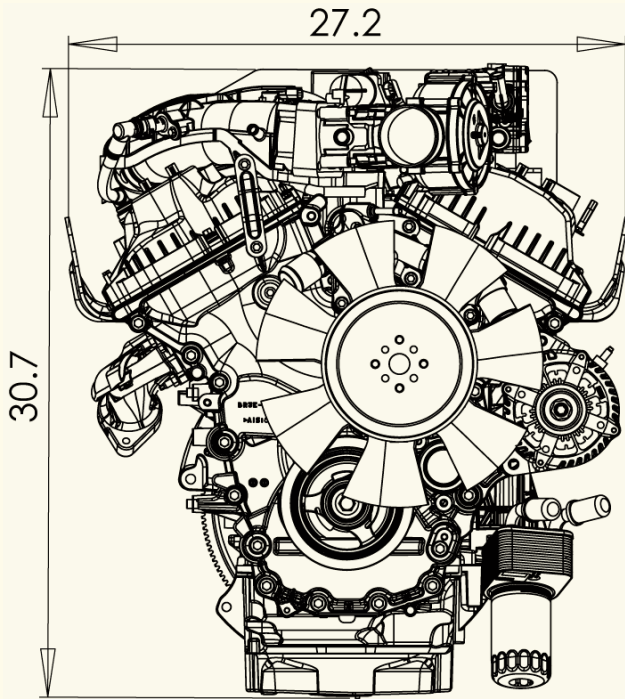

Left Side View

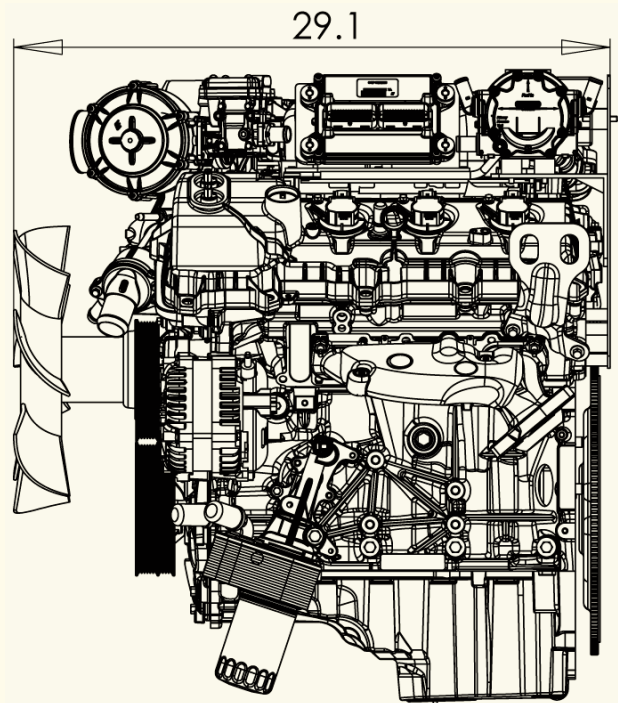

Power Curves (corrected per SAE J1349)

Gasoline

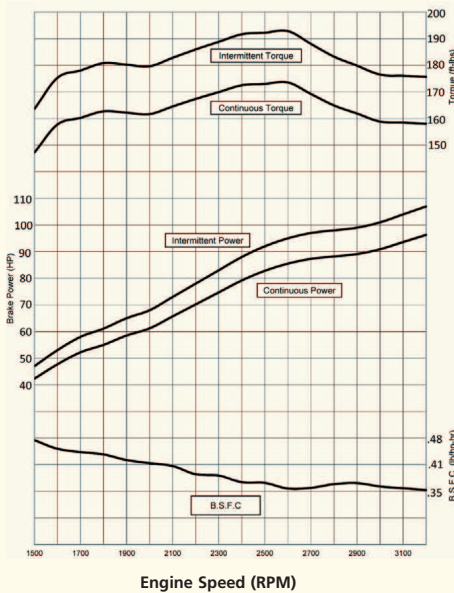

Natural Gas

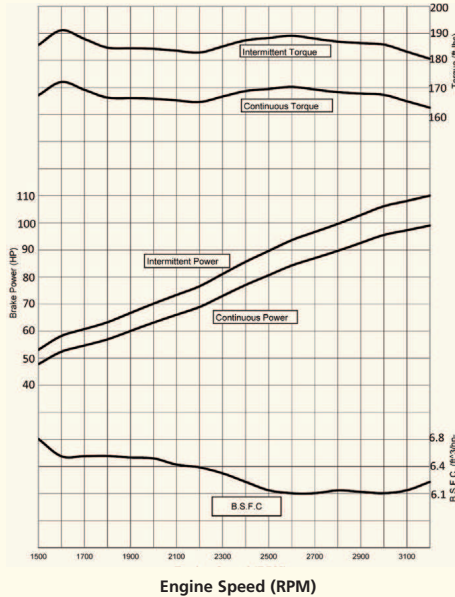

Liquefied Petroleum Gas



Powertrain Assemblies
& Components
Provided By Ford
Component Sales

For additional information Contact:



400 University Ct • Blackwood NJ 08012
856/228-7298 • Fax:856/228-5531
www.edi-dist.com

CSG-637 ^{EFI}

3.7 Liter 6-Cylinder

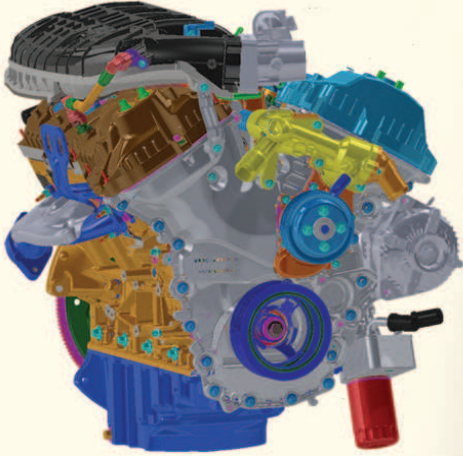

Options

Engine Cooling Fans

- 14" (355mm) diameter suction
- 14" (355mm) diameter pusher

Flywheels

- 11.5" (292mm) SAE over-center clutch
- flat face flywheel

Flywheel Housings

- SAE #3

Exhaust Manifold

- rear dump down

Power Steering Pump

Air Conditioning

Wiring Harnesses

Discrete Speed Switch

Variable Speed Hand Throttle

Variable Speed Foot Pedal

Engine Mounts

- Automotive with insulators
- Open power unit

Electronic Instrument Panel, Gauges

Three Way Catalyst / Muffler Standard

Transmissions

6R80 electronic shift

Emissions Information

California Air Resources Board (CARB)
Environmental Protection Agency (EPA)
Emission Certified Packages

Warranty

Contact Engine Distributors, Inc
for warranty details.



Powertrain Assemblies
& Components
Provided By Ford
Component Sales

Specifications

Engine Type	V-6
Bore and Stroke	3.7" x 3.4" (94mm x 86mm)
Displacement	3.7L Liter (225.7 CID)
Compression Ratio	10.5:1
Oil Capacity	6 qts. including filter
Net Weight	355 Lbs. with accessories (161 Kgs.)
Dimensions	L 25.4" x W 29.5" x H 29.4" (646 mm x 751 mm x 748 mm)

Gasoline (corrected per SAE J1349)

Unleaded 87 or 89 octane		
Intermittent Power	107 [HP] @ 3200rpm	(80 [kW] @ 3200rpm)
Continuous Power	96 [HP] @ 3200rpm	(72 [kW] @ 3200rpm)
Intermittent Torque	193 [ft-lbs] @ 2600rpm	(261 [N-m] @ 2600rpm)
Continuous Torque	173 [ft-lbs] @ 2600rpm	(235 [N-m] @ 3200rpm)

Natural Gas (corrected per SAE J1349)

Fuel Specification	1050 BTU/FT3	
Intermittent Power	110 [HP] @ 3200rpm	(82 [kW] @ 3200rpm)
Continuous Power	99 [HP] @ 3200rpm	(74 [kW] @ 3200rpm)
Intermittent Torque	191 [ft-lbs] @ 1600rpm	(259 [N-m] @ 1600rpm)
Continuous Torque	172 [ft-lbs] @ 1600rpm	(233 [N-m] @ 1600rpm)

Liquefied Petroleum Gas (corrected per SAE J1349)

Fuel Specification	HD-5	
Intermittent Power	118 [HP] @ 3200rpm	(88 [kW] @ 3200rpm)
Continuous Power	106 [HP] @ 3200rpm	(79 [kW] @ 3200rpm)
Intermittent Torque	209 [ft-lbs] @ 2600rpm	(284 [N-m] @ 2600rpm)
Continuous Torque	188 [ft-lbs] @ 2600rpm	(255 [N-m] @ 2600rpm)

Standard Features / Benefits

Set-for-life valvetrain

Deep skirted, ribbed cylinder block casting for rigidity

150 AMP Alternator

Aluminum cylinder block and heads.

Chain driven dual camshafts with automatic tensioning system

Structural front cover and deep sump oil pan

Alternate fuel ready valvetrain components

Individual coil on plug electronic ignition

Four main bolts with side bolts through block for strength
and durability

Gasoline Sequential Port Fuel Injection

Closed loop fuel control for all fuels

Electronic engine management system with built-in engine
protection against detonation, high coolant temperature, low oil
pressure, over speed shutdown and starter lockout

Next generation governing – discrete speeds, variable speeds,
drive by wire – using the highest quality components.

Variable CAM Timing for intake camshafts - advances or retards
timing to maximize engine power and fuel efficiency

Forged steel crankshaft

Pursuant to the authority vested in the Air Resources Board by the Health and Safety Code, Division 26, Part 5, Chapters 1 and 2; and

Pursuant to the authority vested in the undersigned by Health and Safety Code Sections 39515 and 39516 and Executive Order G-14-012;

IT IS ORDERED AND RESOLVED: That the following new large spark-ignition engines and emission control systems produced by the manufacturer are certified for use in off-road equipment as described below. Production engines shall be in all material respects the same as those for which certification is granted.

MODEL YEAR	ENGINE FAMILY NAME	ENGINE DISPLACEMENT (liters)	FUEL TYPE
2016	GEDIB03.7CSG	3.7	Gasoline, LPG, CNG, Gasoline-LPG Dual Fuel, Gasoline-NG Dual Fuel
DURABILITY HOURS	SPECIAL FEATURES & EMISSION CONTROL SYSTEMS		TYPICAL EQUIPMENT USAGE
5000	Three-Way Catalytic Converter, Heated Oxygen Sensor, Sequential Multiport Fuel Injection (Gas), Gaseous Fuel Mixer (LPG, CNG)		Forklift, Aerial Lift, Generator, Compressor, Pump, Other Industrial Equipment
ENGINE MODELS (rated power in kilowatt, kW)		CSG637-DF-LPG-Gas (88.0 kW), CSG637-GAS (80.0 kW), CSG637-LPG (88.0 kW), CSG637-LP VAPOR (88.0 kW), CSG637-NG (82.0 kW), CSG637-DF-NG-GAS (82.0 kW)	

The following are the hydrocarbon plus oxides of nitrogen (HC+NOx) and carbon monoxide (CO) exhaust certification emission standards (Title 13, California Code of Regulations, (13 CCR) Section 2433(b)(1)) and certification emission levels for this engine family in grams per kilowatt-hour (g/kW-hr). Engines within this engine family shall have closed crankcases in conformance with 13 CCR Section 2433(b)(3).

(g/kW-hr)	HC+NOx	CO
Exhaust Standards	0.8	20.6
Certification Levels	0.4	3.3

The following is the evaporative hydrocarbon emission standard (13 CCR Section 2433(b)(4)) and certification emission level for this engine family in grams per gallon of fuel tank capacity (g/gallon).

Evaporative Certification Method	HC Certification Level (g/gallon)	HC Certification Standard (g/gallon)
Design Based	N/A	0.2

BE IT FURTHER RESOLVED: That for the listed engines for the aforementioned model-year, the manufacturer has submitted, and the Executive Officer hereby approves, the information and materials to demonstrate certification compliance with 13 CCR Section 2433(c) (certification and test procedures), 13 CCR Section 2434 (emission control labels), and 13 CCR Sections 2435 and 2436 (emission control system warranty).

Engines certified under this Executive Order must conform to all applicable California emission regulations.

This Executive Order is only granted to the engine family and model-year listed above. Engines in this family that are produced for any other model-year are not covered by this Executive Order.

Executed at El Monte, California on this 24 day of November 2015.



Annette Hebert, Chief
 Emissions Compliance, Automotive Regulations and Science Division



**UNITED STATES ENVIRONMENTAL PROTECTION AGENCY
2016 MODEL YEAR
CERTIFICATE OF CONFORMITY
WITH THE CLEAN AIR ACT**

**OFFICE OF TRANSPORTATION
AND AIR QUALITY
ANN ARBOR, MICHIGAN 48105**

Certificate Issued To: Engine Distributors, Inc.
(U.S. Manufacturer or Importer)
Certificate Number: GEDIB03.7CSG-002

Effective Date:
10/20/2015

Expiration Date:
12/31/2016

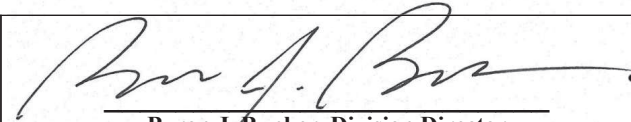
Byron J. Bunker, Division Director
Compliance Division

Issue Date:
10/20/2015
Revision Date:
N/A

Manufacturer: Engine Distributors, Inc.
Engine Family: GEDIB03.7CSG
Mobile/Stationary Certification Type: Mobile and Stationary
Fuel : Gasoline (up to and including 10% Ethanol)
Natural Gas (CNG/LNG)
LPG/Propane
Emission Standards :
Part 60 Subpart JJJJ Table 1
CO (g/kW-hr) : 20.6
NOx (g/kW-hr) : 1.3
CO (g/kW-hr) : 2.7
VOC (g/kW-hr) : 0.9
HC + NOx (g/kW-hr) : 0.8
Mobile Part 1048
CO (g/kW-hr) : 20.6
HC + NOx (g/kW-hr) : 0.8
NMHC + NOx (g/kW-hr) : 0.8
Emergency Use Only : N

Pursuant to Section 213 of the Clean Air Act (42 U.S.C. section 7547) and 40 CFR Part 60, 40 CFR Part 1048, 1065, 1068, and 60 (stationary only and combined stationary and mobile) and subject to the terms and conditions prescribed in those provisions, this certificate of conformity is hereby issued with respect to the test engines which have been found to conform to applicable requirements and which represent the following nonroad engines, by engine family, more fully described in the documentation required by 40 CFR Part 60, 40 CFR Part 1048 and produced in the stated model year.

This certificate of conformity covers only those new nonroad spark-ignition engines which conform in all material respects to the design specifications that applied to those engines described in the documentation required by 40 CFR Part 60, 40 CFR Part 1048 and which are produced during the model year stated on this certificate of the said manufacturer, as defined in 40 CFR Part 60, 40 CFR Part 1048. This certificate of conformity does not cover nonroad engines imported prior to the effective date of the certificate.

It is a term of this certificate that the manufacturer shall consent to all inspections described in 40 CFR 1068.20 and authorized in a warrant or court order. Failure to comply with the requirements of such a warrant or court order may lead to revocation or suspension of this certificate for reasons specified in 40 CFR Part 60, 40 CFR Part 1048. It is also a term of this certificate that this certificate may be revoked or suspended or rendered void *ab initio* for other reasons specified in 40 CFR Part 60, 40 CFR Part 1048.

This certificate does not cover large nonroad engines sold, offered for sale, or introduced, or delivered for introduction, into commerce in the U.S. prior to the effective date of the certificate.

CSG637 Gasoline

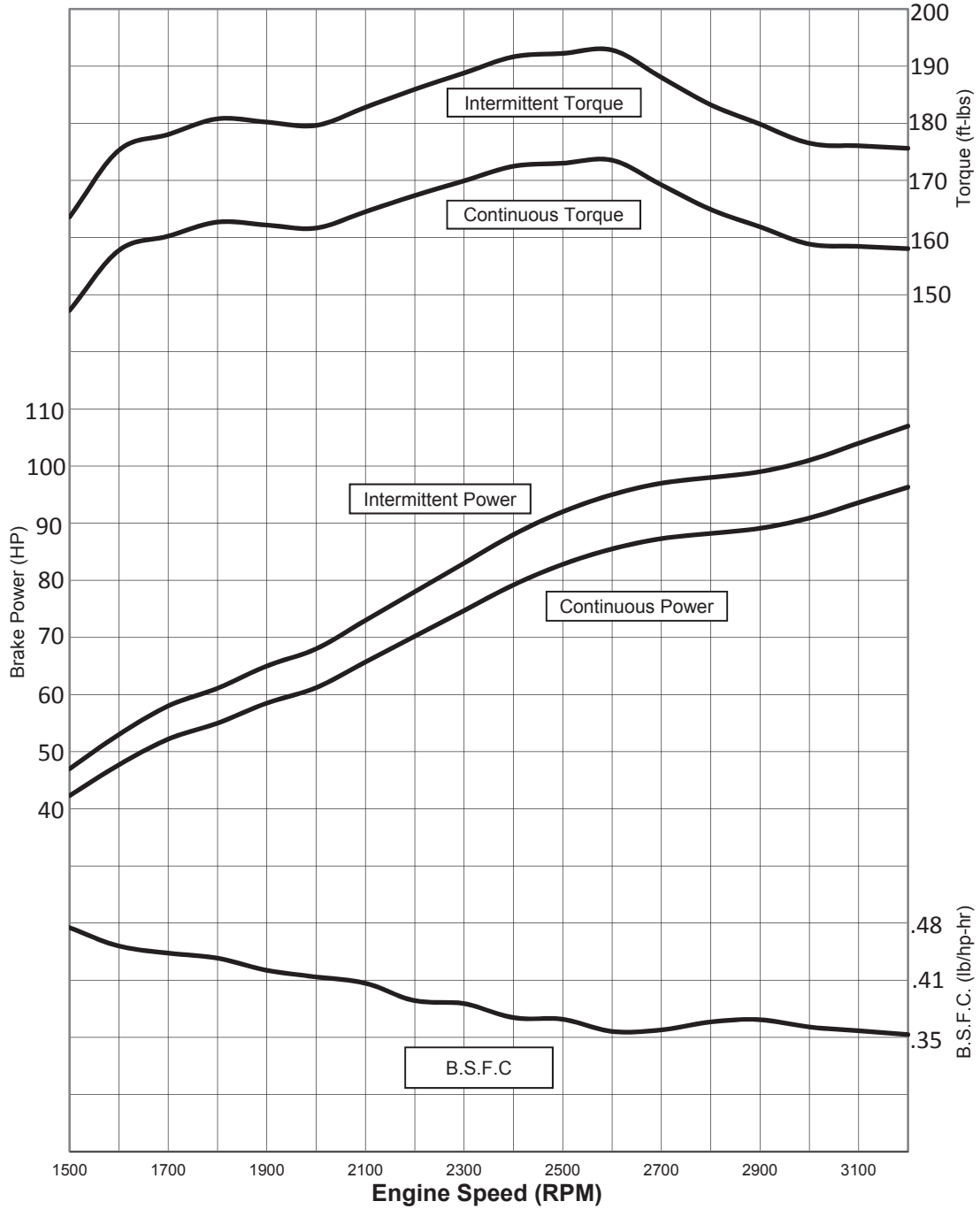

CSG637 Propane

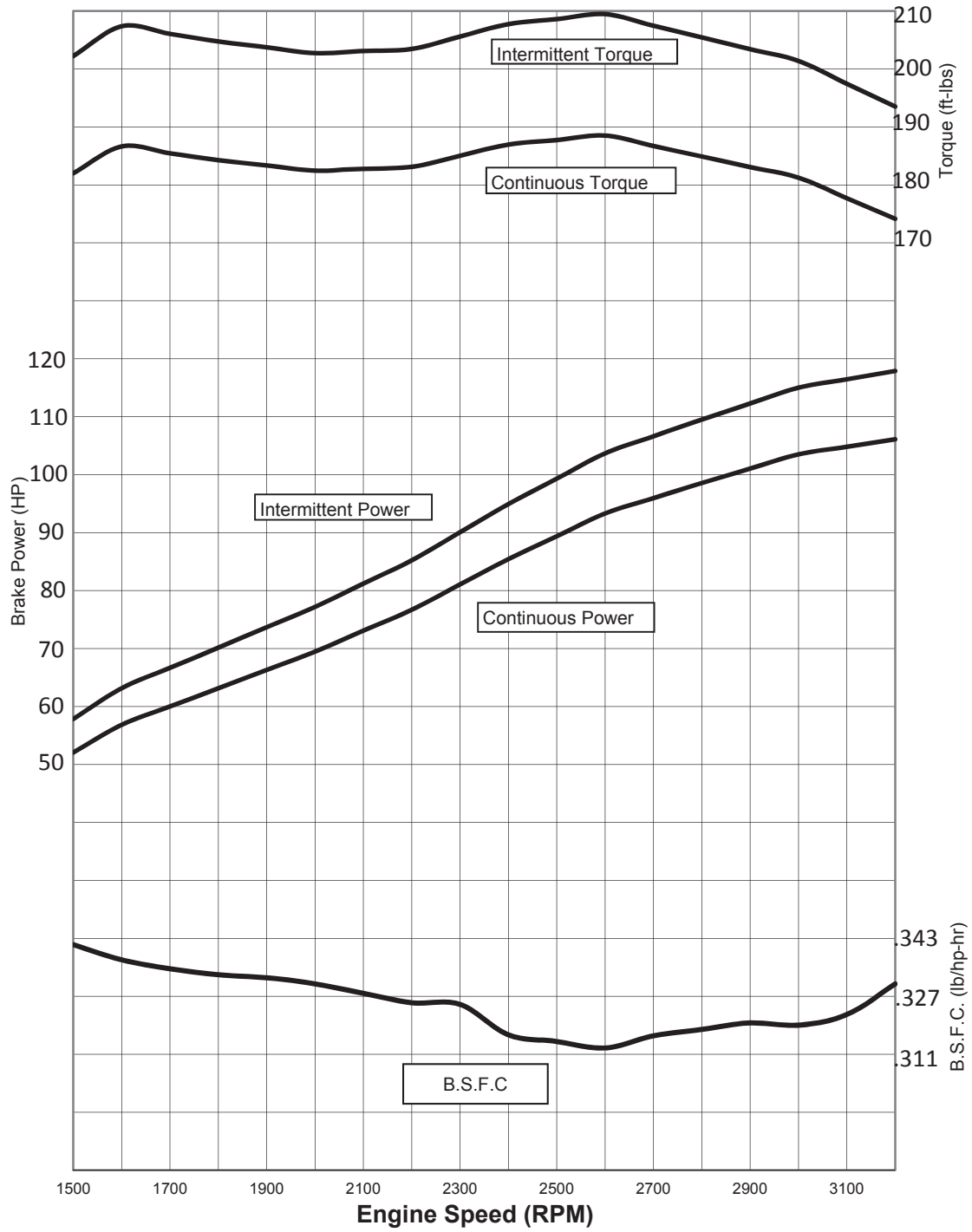

CSG637 Natural Gas

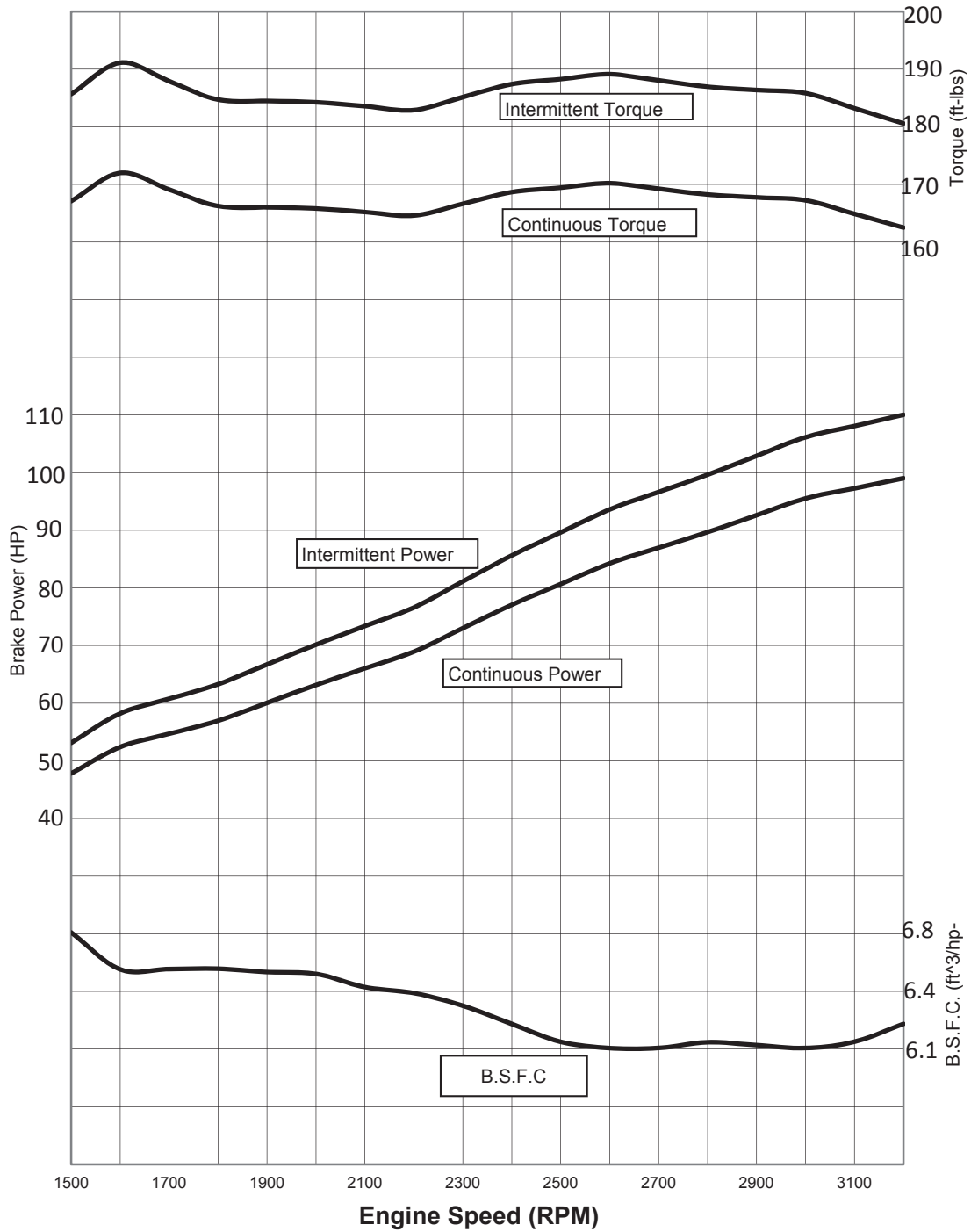

Attachment O

Tanker Truck Loading Data Sheet

ATTACHMENT O – TANKER TRUCK LOADING DATA SHEET

Complete this data sheet for each new or modified bulk liquid transfer area or loading rack at the facility. This is to be used for bulk liquid transfer operations to tanker trucks. Use extra pages if necessary.

Truck Loadout Collection Efficiencies

The following applicable capture efficiencies of a truck loadout are allowed:

- For tanker trucks passing the MACT level annual leak test – 99.2%
- For tanker trucks passing the NSPS level annual leak test – 98.7%
- For tanker trucks not passing one of the annual leak tests listed above – 70%

Compliance with this requirement shall be demonstrated by keeping records of the applicable MACT or NSPS Annual Leak Test certification for **every** truck and railcar loaded/unloaded. This requirement can be satisfied if the trucking company provided certification that its entire fleet was compliant. This certification must be submitted in writing to the Director of the DAQ. These additional requirements must be noted in the Registration Application.

Emission Unit ID#: L001, L002	Emission Point ID#: EP-L001, EP-L002	Year Installed/ Modified: 2017
-------------------------------	--------------------------------------	-----------------------------------

Emission Unit Description: **Condensate Loading, Produced Water Loading**

Loading Area Data

Number of Pumps: **2** Number of Liquids Loaded: **2** Max number of trucks loading at one time: **2**

Are Tanker trucks pressure tested for leaks at this any other location? Yes No Not Required

If Yes, Please Describe: Tank trucks are pressure tested for leaks at the location of the leak testing company. Trucks are tested using EPA Method 27-internal vapor valve test and issued certification that DOT requirements are met.

Provide description of closed vent system and any bypasses

Are any of the following truck loadout systems utilized? **No**

- Closed System to Tanker Truck passing a MACT level annual leak test?
- Closed System to Tanker Truck passing a NSPS level annual leak test?
- Closed System to Tanker Truck not passing an annual leak test and has vapor return?

Projected Maximum Operating Schedule (for rack or transfer point as a whole)

Time	Jan - Mar	Apr - Jun	Jul - Sept	Oct - Dec
Hours/day	11	11	11	11
Days/week	7	7	7	7

Bulk Liquid Data (use extra pages as necessary)

Liquid Name	Condensate	Produced Water	
Max. Daily Throughput (1000 gal/day)	48.17	168.00	
Max. Annual Throughput (1000 gal/yr)	17583.51	61320.00	
Loading Method	BF	BF	
Max. Fill Rate (gal/min)	168	168	
Average Fill Time (min/loading)	50	50	
Max. Bulk Liquid Temperature (F)	72.1	72.1	
True Vapor Pressure	3.1	0.5	
Cargo Vessel Condition	U	U	
Control Equipment or Method	None	None	
Max. Collection Efficiency (%)	0	0	
Max. Control Efficiency (%)	0	0	
Max VOC Emission Rate	Loading (lb/hr)	11.8212	0.0011
	Annual (ton/yr)	10.3104	0.0035
Max HAP Emission Rate	Loading (lb/hr)	1.2352	1.32E-05
	Annual (ton/yr)	1.0773	4.01E-05
Estimation Method	Promax	Promax	

- 1 BF Bottom Fill SP Splash Fill SUB Submerged Fill
- 2 At maximum bulk liquid temperature
- 3 B Ballasted Vessel C Cleaned U Uncleaned (dedicated servi O Other (describe)
- 4 List as many as apply (complete and submit appropriate Air Pollution Control Device Sheets)
- CA Carbon Adsorption VB Dedicated Vapor Balance (closed system)
- ECD Enclosed Combustion Device F Flare
- TO Thermal Oxidization or Incineration
- 5 EPA EPA Emission Factor in AP-42 MB Material Balance
- TM Test Measurement based upon test data submittal O Other (describe)

Attachment S
Air Pollution Control Device – Emission
Reduction Device Sheets

ATTACHMENT S – AIR POLLUTION CONTROL DEVICE / EMISSION REDUCTION DEVICE SHEETS

Complete the applicable air pollution control device sheet s for each flare, vapor combustor, thermal oxidizer, condenser, adsorption system, vapor recovery unit , BTEX Eliminator, Reboiler with and without Glow Plug, etc. at the facility. Use extra pages if necessary.

Emissions calculations must be performed using the most conservative control device efficiency.

The following five (5) rows are only to be completed if registering an alternative air pollution control device.

Emission Unit ID:	NA	Make/Model:	NA
Primary Control Device ID:	NA	Make/Model	NA
Control Efficiency (%):	NA	APCD/ERD Data Sheet Completed	<input type="checkbox"/> Yes <input type="checkbox"/> No
Secondary Control Device ID:	NA	Make/Model	NA
Control Efficiency (%):	NA	APCD/ERD Data Sheet Completed	<input type="checkbox"/> Yes <input type="checkbox"/> No

VAPOR COMBUSTION (Including Enclosed Combustors)

General Information

Control Device ID#:	EC001-003	Installation Date: <input checked="" type="checkbox"/> New <input type="checkbox"/> Modified <input type="checkbox"/> Relocated	
Maximum Rated Total Flow Capacity 5458 scfh	131000 scfd	Maximum Design Heating Input (from mfg. spec sheet) 12.0 MMBTU/hr	Design Heat Content 2300 BTU/scf

Control Device Information

Type of Vapor Combustion Control?

- Enclosed Combustion Device Elevated Flare Ground Flare
 Thermal Oxidizer

Manufacturer: Cimarron	Hours of operation per year?	8760
Model: 48" HV ECD		

List the emission units whose emissions are controlled by this vapor control device (Emission Point ID# NA)

Emission Unit ID#	Emission Source Description	Emission Unit ID#	Emission Source Description
TANKCOND001-008	Condensate Tanks		
TANKPW001-004	Produced Water Tanks		

If this vapor combustor controls emissions from more than six (6) emission units, please attach additional pages.

Assist Type (Flares only) <input type="checkbox"/> Steam <input type="checkbox"/> Air <input type="checkbox"/> Pressure <input checked="" type="checkbox"/> Non	Flare height 25 feet	Tip Diameter 3.33 feet	Was the design per §60.18? <input checked="" type="checkbox"/> Yes <input type="checkbox"/> No Provide determination
---	-------------------------	---------------------------	--

Waste Gas Information

Maximum Waste Gas Flow Rate 27.50 (scfm)	Heat Value of Waste Gas Stream 1,932.52 BTU/ft ³	Exit Velocity of the Emission Stream 0.0526 (ft/s)
---	--	---

Please see Attachment S, Tables 6 & 7 for VOC composition/ characteristics of the waste gas stream to be burned.

Pilot Gas Information

Number of Pilot Lights 3	Fuel Flow Rate to Pilot Flame per Pilot 17 scfh	Heat Input per Pilot 12800 BTU/hr	Will automatic re-ignition be used? <input checked="" type="checkbox"/> Yes <input type="checkbox"/> No
-----------------------------	--	--------------------------------------	--

If automatic re-ignition is used, please describe the method. **Flame Rectification, a thermocouple equivalent**

Is pilot flame equipped with a monitor to detect the presence of the flame? <input checked="" type="checkbox"/> Yes <input type="checkbox"/> No	If Yes, What type? <input checked="" type="checkbox"/> Thermocouple <input type="checkbox"/> Infrared <input type="checkbox"/> Ultraviolet <input type="checkbox"/> Camera <input type="checkbox"/> Other:
--	--

Describe all operating ranges and maintenance procedures required by the manufacturer to maintain the warranty. *(If unavailable, please indicate).*

Additional information attached? Yes No **Manufacturer's specs sheet**

Please attach copies of manufacturer's data sheets, drawings, flame demonstration per §60.18 or §63.11 (b) and performance testing.

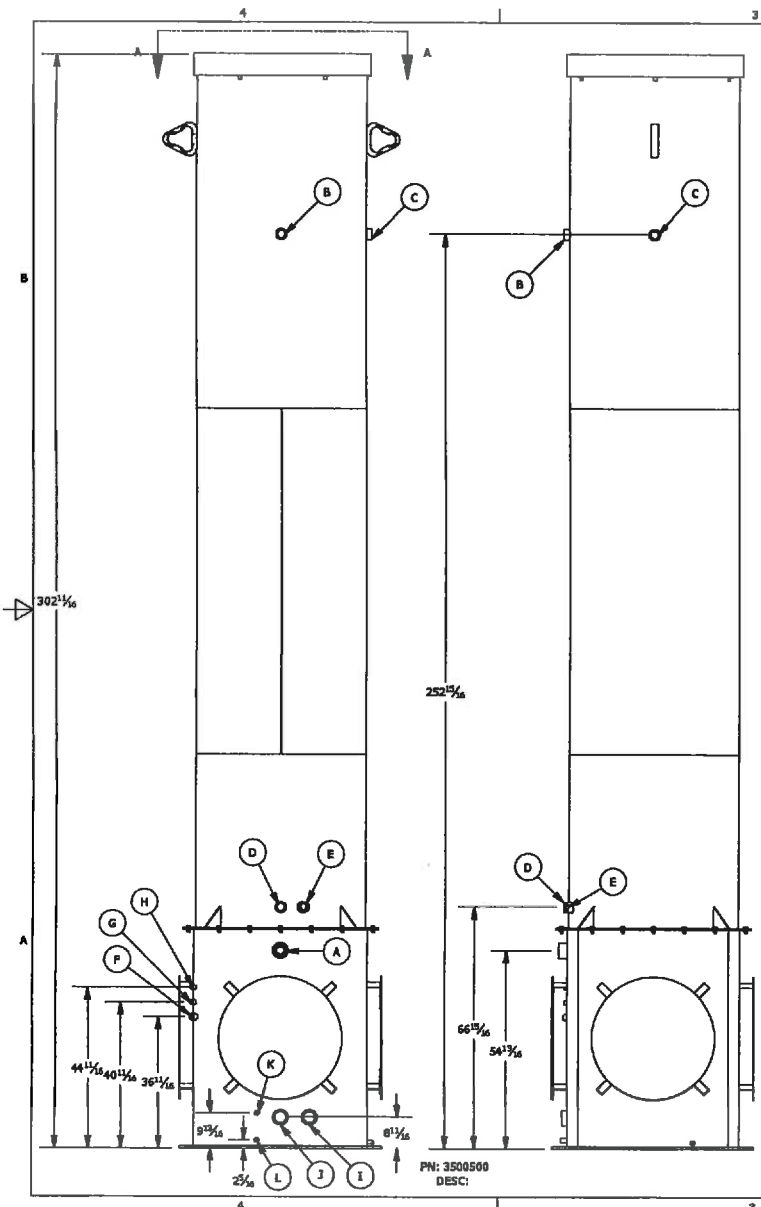

**48" DIA x 302 5/8" HEIGHT, 88 ORIFICES
EMISSION CONTROL DEVICE**

- * >98% TVOC DRE, CERTIFIED USEPA 40 CFR 60, APPENDIX A, SOURCE EMISSIONS TEST METHODS REFERENCED. MEETS ALL EPA & CDPHE REGULATIONS.
- * DESTROYS OIL/CONDENSATE PRODUCTION TANK VAPORS W/ NO VISIBLE FLAME.
- * EXCELLENT OPACITY AND SMOKELESS OPERATION.
- * RELIABLE AND CUSTOMIZABLE IGNITION.
- * VERY LOW CAPITAL AND OPERATING COST.
- * EASY TO OPERATE AND MAINTAIN.
- * FIELD TESTED TO DESTROY UP TO 119.5 MDSCFD (131 MCFD) @ 10 oz/in²; 2300 BTU/CF WASTE GAS (SG 1.45)
- * STRUCTURE CERTIFIED FOR 90 MPH 3-SEC WIND GUST PER ASCE 7-05 & IBC 2006 STANDARDS. HIGHER WIND LOAD RATED STRUCTURES AVAILABLE.

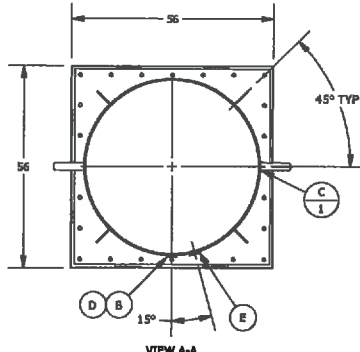

PN: 3500500
DESC:

SCHEDULE OF NOZZLES			
MARK	QTY	DESCRIPTION	SERVICE
A	1	3" HALF COUPLING	2000# BURNER WASTE GAS IN
B	1	2" FULL COUPLING	3000# FLOW TEST/AUTOMATION
C	1	2" FULL COUPLING	3000# FLOW TEST/AUTOMATION
D	1	2" FULL COUPLING	3000# SIGHT GLASS
E	1	2" FULL COUPLING	3000# MANUAL LIGHTING
F	1	1" FULL COUPLING	3000# PILOT GAS IN
G	1	1/2" FULL COUPLING	3000# IGNITOR CABLE
H	1	1/2" FULL COUPLING	3000# AUTOMATION
I	1	3" HALF COUPLING	3000# DRIP TANK WASTE GAS IN
J	1	3" HALF COUPLING	3000# DRIP TANK WASTE GAS OUT
K	1	1/2" FULL COUPLING	3000# AUTOMATION
L	1	1/2" FULL COUPLING	3000# LIQUID DRAIN

- UNLESS OTHERWISE SPECIFIED
1. REMOVE ALL BURRS AND SHARP CORNERS.
 2. COR. RAD .03
 3. DO NOT SCALE DRAWING.
 4. ALL DIMENSIONS ARE IN INCHES.
 5. MACHINE FIN.
 6. FABRICATION AND SHARP CORNERS.
 - .X = ± 0.25
 - .XX = ± 0.125
 - .XXX = ± 0.06
 - ANGLES ± 3°
 7. MACHINE
 - .X = ± 0.030
 - .XX = ± 0.015
 - .XXX = ± 0.005
 - ANGLES ± 1/2°
 - CONTRICTY WITHIN 0.010 TIR

APPROVED FOR A.S.M.E CODE, SECTION VIII DIV 1
ED, ADDENDA BY, DATE

CIMARRON
Energy Inc.

TITLE:
48" HIGH VOLLUME BCD

DATE: _____ WO No.: _____ SHEET: 1 OF 1

DRAWN BY: TDS | REV. | DRAW NO.: 3500500

Attachment T

Emissions Calculations

Table 1

**Facility Information
Addie Well Pad
Doddridge County, West Virginia
Antero Resources Corporation**

Oil and Gas Site General Information

Administrative Information	
Company Name	Antero Resources Corporation
Facility/Well Name	Addie Well Pad
Nearest City/Town	West Union
API Number/SIC Code	1311
Latitude/Longitude	39.333523, -80.805677
County	Doddridge County

Technical Information	
Max Condensate Site Throughput (bbl/day):	1,147
Max Produced Water Site Throughput (bbl/day):	4,000
Are there any sour gas streams at this site?	No
Is this site currently operational/producing?	No

Equipment/Processes at Site	
Equipment/Process Types	How many for this site?
Fugitives	8
IC Engines	3
Gas Production Unit Heaters	8
Line Heaters	8
Condensate Tanks	8
Produced Water Tanks	4
Loading Jobs	2
Vapor Recovery Towers	4
Enclosed Combustors	3

Table 2

**Uncontrolled/Controlled Emissions Summary
Addie Well Pad
Doddridge County, West Virginia
Antero Resources Corporation**

Emission Source	VOC		NO _x		CH ₄		CO _{2e}		CO		SO ₂		PM _{2.5}		PM ₁₀		Lead		Total HAPs		Benzene		Xylenes		Formaldehyde		
	(lbs/hr)	(ton/yr)	(lbs/hr)	(ton/yr)	(lbs/hr)	(ton/yr)	(lbs/hr)	(ton/yr)	(lbs/hr)	(ton/yr)	(lbs/hr)	(ton/yr)	(lbs/hr)	(ton/yr)	(lbs/hr)	(ton/yr)	(lbs/hr)	(ton/yr)	(lbs/hr)	(ton/yr)	(lbs/hr)	(ton/yr)	(lbs/hr)	(ton/yr)	(lbs/hr)	(ton/yr)	
UNCONTROLLED (Fugitives, Storage Tanks, Engine, Gas Production Unit Heaters, Line Heaters)																											
Fugitive Emissions (Component Count, PCV and Hauling) ¹	2.7412	12.0065			3.1532	13.8109	78.831	345.28							1.0619	2.4321			0.3142	1.3763	0.0021	0.0091	5.41E-02	2.37E-01			
Flashing, Working and Breathing (F/W/B) Losses ²	82.7892	362.6168			18.4350	80.7455	461.9867	2023.5017											8.9144	39.0450	0.0297	0.1299	0.1307	0.5724			
VRU Engine Emissions ³	0.0626	0.2743	0.1974	0.8647	0.4866	2.1311	244.8628	1072.4993	1.4225	6.2305	0.0012	0.0054	0.0201	0.0880	0.0201	0.0880			0.0486	0.2127	0.0033	0.0146	0.0004	0.0018	0.0434	0.1899	
Gas Production Unit Heater Emissions ⁵	0.0547	0.2395	0.9943	4.3550	0.0534	0.2337	1,193.14	5,225.97	0.8352	3.6582	0.0060	0.0261	0.0756	0.3310	0.0756	0.3310	4.97E-06	2.18E-05	0.019	0.082	2.09E-05	9.15E-05			0.0007	0.0033	
Line Heater Emissions ⁴	0.0729	0.3194	1.3257	5.8066			1,590.86	6,967.96	1.1136	4.8776	0.0080	0.0348	0.1008	0.4413	0.1008	0.4413	6.63E-06	2.90E-05	0.025	0.109	2.78E-05	1.22E-04			0.0010	0.0044	
TOTALS:	85.7206	375.4564	2.5174	11.0264	22.1281	96.9212	3569.6840	15635.2158	3.3713	14.7662	0.0152	0.0664	0.1964	0.8603	1.2584	3.2924	1.16E-05	5.08E-05	9.3208	40.8253	0.0351	0.1538	0.1852	0.8111	0.0451	0.1976	
UNCONTROLLED (Truck Loading Emissions)																											
Truck Loading Emissions ⁶	11.8223	10.3139			0.1128	0.1788	2.8938	4.6482											1.2352	1.0774	0.0020	1.79E-03	0.0088	0.0077			
CONTROLLED EMISSIONS																											
Enclosed Combustor Emissions (from F/W/B losses) ⁷	1.6561	7.2536	2.4531	10.7446	0.4039	1.7692	454.1136	1989.0175	11.1643	48.8996	3.06E-05	0.0001	0.0097	0.0425	0.0129	0.0566	8.51E-07	3.73E-06	0.1784	0.7813	0.0006	0.0026	0.0026	0.0114	3.83E-06	1.68E-05	
Controlled Fugitive Emissions from Hauling															0.5310	1.2160											
TOTALS:	1.656	7.254	2.453	10.745	0.404	1.769	454.114	1989.017	11.164	48.900	3.06E-05	1.34E-04	0.010	0.042	0.544	1.273	8.51E-07	3.73E-06	0.178	0.781	5.93E-04	2.60E-03	2.61E-03	0.011	3.83E-06	1.68E-05	
POTENTIAL TO EMIT⁸	4.5875	30.4071	4.9705	21.7709	4.0970	18.1238	3561.8109	15605.3797	14.5356	63.6658	0.0152	0.0666	0.2061	0.9028	0.7403	2.1330	1.25E-05	5.45E-05	0.5848	3.6389	0.0061	0.0283	0.0571	0.2579	0.0451	0.1976	
POTENTIAL TO EMIT (Excluding Fugitives)	1.8463	18.4006	4.9705	21.7709	0.9438	4.3129	3482.9798	15260.0995	14.5356	63.6658	0.0152	0.0666	0.2061	0.9028	0.2093	0.9169	1.25E-05	5.45E-05	0.2706	2.2627	0.0040	0.0192	0.0030	0.0210	0.0451	0.1976	

Enter any notes here:	1 - See Tables 4 and 5 for fugitive emission calculations; Table 12 for PM emissions from hauling.
	2 - See Tables 6 and 7 for tanks emission calculations
	3 - See Table 13 for engine emissions
	4 - See Table 9 for line heaters emissions calculations
	5 - See Table 9 for gas production unit heaters emission calculations
	6 - The maximum emission was calculated based on tank truck capacity of 200 barrels and actual fill rate of 50 minutes per tank truck. At a production rate of 1147 barrels per day, VOC emissions would be 11.8223 pounds per hour when there are truck loading activities. Average hourly VOC emissions from truck loading is 2.3548 pound per hour.
	7 - See Table 10 and 11 for enclosed combustion emission calculations.
	8 - The hourly potential to emit is the sum of emissions from gas production unit heaters, line heaters, engines, storage tanks, enclosed combustors, and fugitives. Does not include emissions from loading (see footnote 6). The total TPY PTE is the sum of all emissions. PM 10 TPY is the sum of uncontrolled hauling and other PM10 sources.

Table 3

**Permits Summary
Addie Well Pad
Doddridge County, West Virginia
Antero Resources Corporation**

Pollutant		Emissions		Threshold Exceeded?		
		Uncontrolled	Controlled	Threshold	Uncontrolled	Controlled
VOC	lbs/hr	85.7206	4.5875	6	Yes	
	tons/yr	385.7703	30.4071	10	Yes	Yes
NO _x	lbs/hr	2.5174	4.9705	6		
	tons/yr	11.0264	21.7709	10	Yes	Yes
CH ₄	lbs/hr	22.1281	4.0970			
	tons/yr	97.1000	18.1238			
CO	lbs/hr	3.3713	14.5356	6		Yes
	tons/yr	14.7662	63.6658	10	Yes	Yes
SO ₂	lbs/hr	0.0152	0.0152	6		
	tons/yr	0.0664	0.0666	10		
PM _{2.5}	lbs/hr	0.1964	0.2061	6		
	tons/yr	0.8603	0.9028	10		
PM ₁₀	lbs/hr	1.2584	0.7403	6		
	tons/yr	3.2924	2.1330	10		
Lead	lbs/hr	1.16E-05	1.25E-05	6		
	tons/yr	5.08E-05	5.45E-05	10		
Total HAPs	lbs/hr	9.3208	0.5848	2	Yes	
	tons/yr	41.9027	3.6389	5	Yes	
Total TAPs	lbs/hr	0.0802	0.0512	1.14		
n-Hexane	lbs/hr	8.8329	0.4327			
	tons/yr	39.7443	2.9518			
Toluene	lbs/hr	0.1437	0.0216			
	tons/yr	0.6371	0.1023			
Ethylbenzene	lbs/hr	0.0786	0.0220			
	tons/yr	0.3481	0.1000			
Xylenes	lbs/hr	0.1852	0.0571			
	tons/yr	0.8188	0.2579			
Benzene	lbs/hr	0.0351	0.0061			
	tons/yr	0.1556	0.0283			

Enter any notes here:	<p>1. Emissions are based on 98% Enclosed Combustor DRE operating 100% of the time.</p> <p>2. Please see Attachment J - Fugitive Emissions Data Summary Sheet and Attachment T - Emission Points Summary Sheet for sitewide sources and breakdown of emission quantities.</p>
------------------------------	---

Table 4

**Fugitive Emissions
Addie Well Pad
Doddridge County, West Virginia
Antero Resources Corporation**

VOC Type:	Condensate VOC
Emission Type:	Steady State (continuous)

Gas Weight Fraction From Analysis:	VOC frac	0.117
	Benzene frac	0.000
	Toluene	0.000
	Ethylbenzene	0.000
	Xylenes	0.000
	n-Hexane	0.015
	HAPs	0.015
	Methane	0.663

Gas					
Number	Component	Pollutant	Emission Factor (kg/hr of THC per component)	kg/hr	lb/yr
400	Valves	Gas VOC	0.004500	0.21	4,063.53
		Non VOC	0.004500	1.59	30,626.07
		HAPs	0.004500	0.03	536.24
		CO2e	0.004500	29.83	574,931.35
472	Connectors	VOC	0.000200	0.01	213.11
		Non-VOC	0.000200	0.08	1,606.17
		HAPs	0.000200	0.00	28.12
		CO2e	0.000200	1.56	30,151.96
104	Flanges	VOC	0.000390	0.00	91.56
		Non-VOC	0.000390	0.04	690.11
		HAPs	0.000390	0.00	12.08
		CO2e	0.000390	0.672225	12955.119675
Total VOCs:				0.23	4368.20
Total THC:				1.93	37290.55
Total CH4:				1.28	24721.54

Light Liquid Weight Fraction From Analysis:	VOC frac	0.957
	Benzene frac	0.001
	Toluene	0.008
	Ethylbenzene	0.009
	Xylenes	0.024
	n-hexane	0.064
	HAPs	0.106
	Methane	0.013

Light Liquid					
Number	Component	Pollutant	Emission Factor (kg/hr of THC per component)	kg/hr	lb/yr
416	Valves	Light Liquid VOC	0.002500	1.00	19,179.06
		Light Liquid Non-VOC	0.002500	0.04	863.82
		Light Liquid HAPs	0.002500	0.11	2,114.67
		CO2e	0.002500	0.34	6612.99
Total VOC:				1.00	19,179.06
Total THC:				1.04	20,042.88
Total CH4:				0.01	264.52

Fugitive Total Emissions			
	Annual Emissions (lb/yr)	Annual Emissions (lb/hr)	Annual Emissions (tpy)
VOC	23,547.26	2.69	11.77
Ethylbenzene		0.02	0.09
Toluene		0.02	0.08
Xylenes		0.05	0.24
n-Hexane		0.21	0.93
TAPs (Benzene)		0.00	0.01
HAPs		0.31	1.35
CH ₄ ³		2.85	12.49
CO _{2e}	624,651.42	71.31	312.33

Enter Notes Here: Fugitive emissions based on an estimated component count
Global Warming Potentials from EPA site
Reference to Emission factors used:
1. Emission factors are for oil and gas production facilities (not refineries) come from the EPA's "Protocol for Equipment Leak Emission Estimates" November 1995, EPA 4531, R-95-017, Table 2-4.
2. Percent of speciated VOCs used in fugitive calculations are based on the total hydrocarbons, not of the total sample.
3. CH₄ emissions are based on percent of CH4 of the total hydrocarbons

Table 5

**Pneumatic Control Valve Emissions
Addie Well Pad
Doddridge County, West Virginia
Antero Resources Corporation**

Number of PCVs	32
Bleed Rate (scf/day/PCV)	6.6
Total Bleed Rate (scf/day)	211.2

Component	Mol%	Molecular Weight (lb/lb-mole)	Component Flow (scf/day)	Component Moles (lb-moles)	Component Emissions		
					(lbs/day)	(lbs/hr)	(tons/year)
H2S	0.00E+00	34.08	0.00E+00	0.00E+00	0.00E+00	0.00E+00	0.00E+00
Nitrogen	0.4085	14.01	0.862752	2.27E-03	0.03	1.33E-03	0.01
Carbon Dioxide	0.1743	44.01	0.3681216	9.70E-04	0.04	1.78E-03	7.79E-03
Methane	80.8909	16.04	170.8415808	0.45	7.22	0.30	1.32
Ethane	14.3137	30.07	30.2305344	0.08	2.40	0.10	0.44
Propane	2.2213	44.1	4.6913856	0.01	0.55	0.02	0.10
Isobutane	0.4547	58.12	0.9603264	2.53E-03	0.15	0.01	0.03
n-Butane	0.7773	58.12	1.6416576	4.33E-03	0.25	0.01	0.05
Isopentane	0.2153	72.15	0.4547136	1.20E-03	0.09	3.60E-03	0.02
n-Pentane	0.1929	72.15	0.4074048	1.07E-03	0.08	3.23E-03	0.01
2-Methylpentane	0.00E+00	86.18	0.00E+00	0.00E+00	0.00E+00	0.00E+00	0.00E+00
3-Methylpentane	0.00E+00	86.18	0.00E+00	0.00E+00	0.00E+00	0.00E+00	0.00E+00
n-Hexane	0.3511	86.18	0.7415232	1.95E-03	0.17	0.01	0.03
Methylcyclopentane	0.00E+00	84.16	0.00E+00	0.00E+00	0.00E+00	0.00E+00	0.00E+00
Benzene	0.00E+00	78.11	0.00E+00	0.00E+00	0.00E+00	0.00E+00	0.00E+00
2-Methylhexane	0.00E+00	100.2	0.00E+00	0.00E+00	0.00E+00	0.00E+00	0.00E+00
3-Methylhexane	0.00E+00	100.2	0.00E+00	0.00E+00	0.00E+00	0.00E+00	0.00E+00
Heptane	0.00E+00	100.21	0.00E+00	0.00E+00	0.00E+00	0.00E+00	0.00E+00
Methylcyclohexane	0.00E+00	98.186	0.00E+00	0.00E+00	0.00E+00	0.00E+00	0.00E+00
Toluene	0.00E+00	92.14	0.00E+00	0.00E+00	0.00E+00	0.00E+00	0.00E+00
Octane	0.00E+00	114.23	0.00E+00	0.00E+00	0.00E+00	0.00E+00	0.00E+00
Ethylbenzene	0.00E+00	106.17	0.00E+00	0.00E+00	0.00E+00	0.00E+00	0.00E+00
m & p-Xylene	0.00E+00	106.16	0.00E+00	0.00E+00	0.00E+00	0.00E+00	0.00E+00
o-Xylene	0.00E+00	106.16	0.00E+00	0.00E+00	0.00E+00	0.00E+00	0.00E+00
Nonane	0.00E+00	128.2	0.00E+00	0.00E+00	0.00E+00	0.00E+00	0.00E+00
C10+	0.00E+00	174.28	0.00E+00	0.00E+00	0.00E+00	0.00E+00	0.00E+00

	lb/hr	tpy
VOC Emissions	0.0532	0.2329
Benzene Emissions	0.00E+00	0.00E+00
Toluene Emissions	0.00E+00	0.00E+00
Ethylbenzene Emissions	0.00E+00	0.00E+00
Xylene Emissions	0.00E+00	0.00E+00
n-Hexane Emissions	0.0070	0.0307
HAPs Emissions	0.0070	0.0307
TAPs Emissions	0.00E+00	0.00E+00
CH ₄ Emissions	0.3009	1.3179
CO _{2e} emissions	7.5239	32.9545

Enter any notes here:	1. PCV bleed rate obtained from the user manual for PCV
	2. Emissions per hour= Mol % x no. of PCV x bleed rate x MW / 379.48 / 24

Table 6

Uncontrolled Flashing Emissions
Addie Well Pad
Doddridge County, West Virginia
Antero Resources Corporation

# Hours Operational	8760
---------------------	------

	Condensate Tank Flashing Losses			Produced Water Tank Flashing Losses		
	Vapor Mass Fraction wt%	Flashing Losses		Vapor Mass Fraction wt%	Flashing Losses	
		lbs/hr	tpy		lbs/hr	tpy
Water	0.1044	0.0908	0.3975	2.4327	0.6867	3.0079
H2S	0.0000	0.0000	0.0000	0.0000	0.0000	0.0000
Nitrogen	0.0008	0.0007	0.0030	0.2677	0.0756	0.3310
Carbon Dioxide	0.1494	0.1299	0.5688	3.3082	0.9339	4.0905
Methane	2.3488	2.0411	8.9398	57.5713	16.2520	71.1836
Ethane	29.8444	25.9339	113.5906	25.8765	7.3047	31.9948
Propane	21.8873	19.0194	83.3051	4.0704	1.1490	5.0328
Isobutane	7.9356	6.8958	30.2038	3.6249	1.0233	4.4820
n-Butane	14.9049	12.9519	56.7293	1.6243	0.4585	2.0084
Isopentane	5.5673	4.8378	21.1898	0.3939	0.1112	0.4870
n-Pentane	5.3480	4.6472	20.3549	0.1456	0.0411	0.1801
2-Methylpentane	0.6954	0.6043	2.6467	0.0256	0.0072	0.0317
3-Methylpentane	0.4631	0.4024	1.7624	0.0414	0.0117	0.0512
n-Hexane	7.3321	6.3714	27.9065	0.1323	0.0373	0.1635
Methylcyclopentane	0.1666	0.1447	0.6339	0.0245	0.0069	0.0302
Benzene	0.0196	0.0170	0.0745	0.0320	0.0090	0.0395
2-Methylhexane	0.5228	0.4543	1.9900	0.0138	0.0039	0.0171
3-Methylhexane	0.4186	0.3637	1.5932	0.0133	0.0038	0.0165
Heptane	0.7585	0.6591	2.8870	0.0102	0.0029	0.0126
Methylcyclohexane	0.4064	0.3532	1.5469	0.0593	0.0167	0.0733
Toluene	0.0833	0.0724	0.3172	0.1289	0.0364	0.1594
Octane	0.7091	0.6162	2.6989	0.0040	0.0011	0.0049
Ethylbenzene	0.0386	0.0335	0.1469	0.0581	0.0164	0.0719
m & p-Xylene	0.0423	0.0368	0.1610	0.0591	0.0167	0.0730
o-Xylene	0.0467	0.0406	0.1778	0.0740	0.0209	0.0915
Nonane	0.1459	0.1268	0.5554	0.0009	0.0003	0.0011
C10+	0.0600	0.0522	0.2285	0.0071	0.0020	0.0088
Total VOCs	67.552	58.70	257.1	10.544	2.9764	13.0365
Total CO _{2e}		51.16	224.1		407.23	1,783.7
CH ₄		2.04	8.94		16.25	71.18
Total TAPs (Benzene)		0.0170	0.0745		0.0090	0.0395
Toluene		0.0724	0.3172		0.0364	0.1594
Ethylbenzene		0.0335	0.1469		0.0164	0.0719
Xylenes		0.0774	0.3388		0.0376	0.1645
n-Hexane		6.371	27.907		0.0373	0.1635
Total HAPs		6.572	28.784		0.1367	0.5989
Total	100.00	86.90	380.6	100.00	28.229	123.64

Enter any notes here:	Vapor mass fractions and Flashing losses from Promax output
-----------------------	---

Table 7

Uncontrolled Working and Breathing Losses
Addie Well Pad
Doddridge County, West Virginia
Antero Resources Corporation

Condensate Tank Information	
Number of Tanks	8
Maximum Working Losses (lbs/hr)	10.1684
Maximum Breathing Losses (lbs/hr)	22.9178
# Hours Operational	8760

	Condensate Tank W/B Losses						
	Vapor Mass Fraction wt%	Working Losses		Breathing Losses		Max W/B Losses	
		lbs/hr	tpy	lbs/hr	tpy	lbs/hr	tpy
H2S	0.00E+00	0.00E+00	0.00E+00	0.00E+00	0.00E+00	0.00E+00	0.00E+00
Nitrogen	0.0000	1.84E-06	8.04E-06	0.0000	0.0000	0.0000	0.0000
Carbon Dioxide	0.1133	0.0115	0.0505	0.0260	0.1138	0.0375	0.1642
Methane	0.4089	0.0416	0.1821	0.0937	0.4104	0.1353	0.5925
Ethane	35.6692	3.6270	15.8862	8.1746	35.8048	11.8016	51.6910
Propane	22.3468	2.2723	9.9527	5.1214	22.4318	7.3937	32.3845
Isobutane	7.7630	0.7894	3.4574	1.7791	7.7925	2.5685	11.2499
n-Butane	14.2556	1.4496	6.3491	3.2671	14.3097	4.7166	20.6588
Isopentane	4.8549	0.4937	2.1622	1.1126	4.8734	1.6063	7.0356
n-Pentane	4.6127	0.4690	2.0544	1.0571	4.6302	1.5262	6.6845
2-Methylpentane	0.6028	0.0613	0.2685	0.1382	0.6051	0.1995	0.8736
3-Methylpentane	0.4011	0.0408	0.1787	0.0919	0.4027	0.1327	0.5813
n-Hexane	6.5374	0.6647	2.9116	1.4982	6.5622	2.1630	9.4738
Methylcyclopentane	0.1315	0.0134	0.0586	0.0301	0.1320	0.0435	0.1905
Benzene	0.0110	1.12E-03	0.0049	0.0025	0.0110	0.0036	0.0159
2-Methylhexane	0.1237	1.26E-02	0.0551	0.0283	0.1241	0.0409	0.1792
3-Methylhexane	0.3626	0.0369	0.1615	0.0831	0.3640	0.1200	0.5255
Heptane	0.6255	0.0636	0.2786	0.1434	0.6279	0.2070	0.9065
Methylcyclohexane	0.3442	0.0350	0.1533	0.0789	0.3455	0.1139	0.4988
Toluene	0.0478	4.86E-03	2.13E-02	0.0109	0.0479	0.0158	0.0692
Octane	0.5670	0.0576	0.2525	0.1299	0.5691	0.1876	0.8216
Ethylbenzene	0.0237	2.41E-03	1.05E-02	0.0054	0.0238	0.0078	0.0343
m & p-Xylene	0.0238	2.42E-03	1.06E-02	0.0055	0.0239	0.0079	0.0345
o-Xylene	0.0238	2.42E-03	0.0106	0.0055	0.0239	0.0079	0.0345
Nonane	0.1139	0.0116	0.0507	0.0261	0.1143	0.0377	0.1650
C10+	0.0359	3.65E-03	0.0160	0.0082	0.0360	0.0119	0.0520
Total VOCs	63.809	6.4883	28.419	14.6235	64.0510	21.1118	92.470
Total CO _{2e}		1.0509	4.6028	2.3685	10.3740	3.4194	14.977
CH ₄		0.0416	0.1821	0.0937	0.4104	0.1353	0.5925
Total TAPs (Benzene)		1.12E-03	4.89E-03	0.0025	0.0110	0.0036	0.0159
Toluene		4.86E-03	2.13E-02	0.0109	0.0479	0.0158	0.0692
Ethylbenzene		2.41E-03	1.05E-02	0.0054	0.0238	0.0078	0.0343
Xylenes		4.84E-03	0.0212	0.0109	0.0478	0.0158	0.0690
n-Hexane		0.6647	2.9116	1.4982	6.5622	2.1630	9.4738
Total HAPs		0.6780	2.9695	1.5280	6.6927	2.2060	9.6622
Total	100.00	10.1684	44.5374	22.9178	100.3801	33.0862	144.917

Table 7

Uncontrolled Working and Breathing Losses
Addie Well Pad
Doddridge County, West Virginia
Antero Resources Corporation

Produced Water Tank Information	
Number of Tanks	4
Maximum Working Losses (lbs/hr)	0.1995
Maximum Breathing Losses (lbs/hr)	0.0168

	Produced Water Tank W/B Losses						
	Vapor Mass Fraction wt%	Working Losses		Breathing Losses		Max W/B Losses	
		lbs/hr	tpy	lbs/hr	tpy	lbs/hr	tpy
Water	90.7213	0.1809	0.7926	0.0152	0.0667	0.1962	0.8592
H2S	0.00E+00	0.00E+00	0.00E+00	0.00E+00	0.00E+00	0.00E+00	0.00E+00
Nitrogen	0.0052	1.04E-05	4.54E-05	8.73E-07	3.82E-06	1.12E-05	4.93E-05
Carbon Dioxide	4.3877	0.0088	0.0383	0.0007	0.0032	0.0095	0.0416
Methane	3.1128	0.0062	0.0272	0.0005	0.0023	0.0067	0.0295
Ethane	1.6776	0.0033	0.0147	0.0003	0.0012	0.0036	0.0159
Propane	0.0412	8.22E-05	0.0004	6.92E-06	3.03E-05	8.92E-05	0.0004
Isobutane	0.0492	9.80E-05	4.29E-04	8.25E-06	3.61E-05	1.06E-04	4.66E-04
n-Butane	0.0037	7.40E-06	3.24E-05	6.22E-07	2.73E-06	8.02E-06	3.51E-05
Isopentane	0.0002	4.71E-07	2.06E-06	3.96E-08	1.74E-07	5.11E-07	2.24E-06
n-Pentane	0.0000	4.97E-08	2.18E-07	4.18E-09	1.83E-08	5.39E-08	2.36E-07
2-Methylpentane	2.45E-06	4.89E-09	2.14E-08	4.11E-10	1.80E-09	5.30E-09	2.32E-08
3-Methylpentane	8.84E-06	1.76E-08	7.73E-08	1.48E-09	6.50E-09	1.91E-08	8.38E-08
n-Hexane	4.42E-06	8.81E-09	3.86E-08	7.41E-10	3.25E-09	9.55E-09	4.18E-08
Methylcyclopentane	6.28E-06	1.25E-08	5.49E-08	1.05E-09	4.62E-09	1.36E-08	5.95E-08
Benzene	4.97E-04	9.92E-07	4.35E-06	8.35E-08	3.66E-07	1.08E-06	4.71E-06
2-Methylhexane	7.93E-08	1.58E-10	6.92E-10	1.33E-11	5.83E-11	1.71E-10	7.51E-10
3-Methylhexane	3.03E-07	6.04E-10	2.64E-09	5.08E-11	2.22E-10	6.54E-10	2.87E-09
Heptane	7.35E-08	1.47E-10	6.42E-10	1.23E-11	5.40E-11	1.59E-10	6.96E-10
Methylcyclohexane	4.93E-06	9.82E-09	4.30E-08	8.27E-10	3.62E-09	1.07E-08	4.67E-08
Toluene	4.34E-04	8.65E-07	3.79E-06	7.28E-08	3.19E-07	9.37E-07	4.11E-06
Octane	3.54E-09	7.06E-12	3.09E-11	5.94E-13	2.60E-12	7.65E-12	3.35E-11
Ethylbenzene	5.93E-05	1.18E-07	5.18E-07	9.96E-09	4.36E-08	1.28E-07	5.62E-07
m & p-Xylene	3.80E-05	7.57E-08	3.32E-07	6.37E-09	2.79E-08	8.21E-08	3.60E-07
o-Xylene	7.38E-05	1.47E-07	6.44E-07	1.24E-08	5.42E-08	1.60E-07	6.99E-07
Nonane	2.51E-10	5.01E-13	2.19E-12	4.21E-14	1.85E-13	5.43E-13	2.38E-12
C10+	6.73E-09	1.34E-11	5.88E-11	1.13E-12	4.95E-12	1.46E-11	6.37E-11
Total VOCs	0.0955	1.90E-04	0.0008	1.60E-05	7.02E-05	2.06E-04	0.0009
Total CO _{2e}		0.1640	0.7182	0.0138	0.0604	0.1778	0.7786
CH ₄		0.0062	0.0272	0.0005	0.0023	0.0067	0.0295
Total TAPs (Benzene)		9.92E-07	4.35E-06	8.35E-08	3.66E-07	1.08E-06	4.71E-06
Toluene		8.65E-07	3.79E-06	7.28E-08	3.19E-07	9.37E-07	4.11E-06
Ethylbenzene		1.18E-07	5.18E-07	9.96E-09	4.36E-08	1.28E-07	5.62E-07
Xylenes		2.23E-07	9.76E-07	1.88E-08	8.21E-08	2.42E-07	1.06E-06
n-Hexane		8.81E-09	3.86E-08	7.41E-10	3.25E-09	9.55E-09	4.18E-08
Total HAPs		2.21E-06	9.67E-06	1.86E-07	8.13E-07	2.39E-06	1.05E-05
Total	100.00	0.1995	0.8736	0.0168	0.0735	0.2162	0.9471

Enter any notes here:	Vapor mass fractions, working losses and breathing losses from Promax output
------------------------------	--

Table 8

Loading Emissions
Addie Well Pad
Doddridge County, West Virginia
Antero Resources Corporation

Annual Loading	Oil Truck Loading	Water Truck Loading
RVP	4.41	1.0339
Annual Average Temp (F)	72.1	72.1
S (saturation factor)	0.6	0.6
P (true vapor pressure)	3.07	0.45
M (MW of vapor)	42.61	18.56
Collection Efficiency (%)	0.00	0.00
Total Hydrocarbon Loading Loss (lb/10 ³ gal)*	1.84	0.12
Maximum Throughput (gallons/hr)**	10,080	10,080
Average Throughput (gallons/yr)	17,583,510	61,320,000
Total Hydrocarbon Loading Emissions (lbs/hr)	18.53	1.19
Total Hydrocarbon Loading Emissions (tpy)	16.16	3.62

	Condensate Tank Loading Losses			Produced Water Tank Loading Losses		
	Vapor Mass Fraction wt%	Loading Losses lbs/hr	Loading Losses tpy	Vapor Mass Fraction wt%	Loading Losses lbs/hr	Loading Losses tpy
H2S	0.0000	0.00E+00	0.00E+00	0.00E+00	0.00E+00	0.00E+00
Nitrogen	0.0000	3.34E-06	2.92E-06	0.0052	6.20E-05	1.88E-04
Carbon Dioxide	0.1133	0.0210	1.83E-02	4.3877	5.23E-02	1.59E-01
Methane	0.4089	0.0757	6.61E-02	3.1128	3.71E-02	1.13E-01
Ethane	35.6692	6.6081	5.7636	1.6776	2.00E-02	6.08E-02
Propane	22.3468	4.1400	3.61E+00	0.0412	4.91E-04	1.49E-03
Isobutane	7.7630	1.4382	1.25E+00	0.0492	5.86E-04	1.78E-03
n-Butane	14.2556	2.6410	2.30E+00	0.0037	4.42E-05	1.34E-04
Isopentane	4.8549	0.8994	7.84E-01	0.0002	2.81E-06	8.56E-06
n-Pentane	4.6127	0.8545	7.45E-01	0.0000	2.97E-07	9.03E-07
2-Methylpentane	0.6028	0.1117	9.74E-02	2.45E-06	2.92E-08	8.88E-08
3-Methylpentane	0.4011	0.0743	6.48E-02	8.84E-06	1.05E-07	3.20E-07
n-Hexane	6.5374	1.2111	1.06E+00	4.42E-06	5.26E-08	1.60E-07
Methylcyclopentane	0.1315	0.0244	2.12E-02	6.28E-06	7.48E-08	2.28E-07
Benzene	0.0110	0.0020	1.78E-03	0.0005	5.92E-06	1.80E-05
2-Methylhexane	0.1237	0.0229	2.00E-02	7.93E-08	9.44E-10	2.87E-09
3-Methylhexane	0.3626	0.0672	5.86E-02	3.03E-07	3.60E-09	1.10E-08
Heptane	0.6255	0.1159	1.01E-01	7.35E-08	8.75E-10	2.66E-09
Methylcyclohexane	0.3442	0.0638	5.56E-02	4.93E-06	5.87E-08	1.78E-07
Toluene	0.0478	0.0088	7.72E-03	0.0004	5.16E-06	1.57E-05
Octane	0.5670	0.1050	9.16E-02	3.54E-09	4.22E-11	1.28E-10
Ethylbenzene	0.0237	0.0044	3.83E-03	5.93E-05	7.07E-07	2.15E-06
m & p-Xylene	0.0238	0.0044	3.85E-03	3.80E-05	4.52E-07	1.38E-06
o-Xylene	0.0238	0.0044	3.85E-03	7.38E-05	8.79E-07	2.67E-06
Nonane	0.1139	0.0211	1.84E-02	2.51E-10	2.99E-12	9.10E-12
C10+	0.0359	0.0067	5.80E-03	6.73E-09	8.02E-11	2.44E-10
Total VOCs	63.8085	11.8212	10.3104	0.0955	1.14E-03	3.46E-03
Total CH ₄		0.0757	0.0661		0.0371	0.1128
Total CO _{2e}		1.9146	1.6699		0.9791	2.9782
Total TAPs (Benzene)		0.0020	1.78E-03		5.92E-06	1.80E-05
Toluene		0.0088	7.72E-03		5.16E-06	1.57E-05
Ethylbenzene		0.0044	3.83E-03		7.07E-07	2.15E-06
Xylenes		0.0088	7.69E-03		1.33E-06	4.05E-06
n-Hexane		1.2111	1.06E+00		5.26E-08	1.60E-07
Total HAPs		1.2352	1.08E+00		1.32E-05	4.01E-05
Total	100.0000	18.5261	16.1584	100.0000	1.1911	3.6229

Enter any notes here

Vapor mass fractions and loading losses from Promax output

*Using equation $L_i = 12.46 \cdot SPM/T$ from AP-42, Chapter 5, Section 5.2-4

MW was obtained by Promax; RVP was taken from laboratory reports

Annual Average Temp (F) obtained from Charleston, WV (preset in Promax)

S (saturation factor) is based on submerged loading, dedicated service as it was most representative

True vapor pressure (TVP) equation from AP-42, Chapter 7, Figure 7.1-13a

** Maximum throughput in gallons per hour obtained from actual transfer rate of 200 barrels in 50 minutes. (10,080 gal/hr = 200 bbl / 50 min x 42 gal/bbl x 60 min/hr)

Loading emissions are vented to the atmosphere.

Table 9

Gas Production Unit Heater and Line Heater Emissions
Addie Well Pad
Doddridge County, West Virginia
Antero Resources Corporation

Gas Production Unit Heater Emissions

Number of Units	8
GPU Heater Rating (MMBtu/hr)	1.50
Operating hours/year	8760
Fuel Heat Value (Btu/scf)	1,206.8951

Pollutant	Emission Factors (lb/MMscf)	lb/hr	tpy
NOx	100	0.994	4.355
CO	84	0.835	3.658
CO ₂	120,000	1193.144	5225.972
Lead	0.0005	4.97E-06	2.18E-05
N ₂ O	2.2	0.022	0.096
PM (Total)	7.6	0.076	0.331
SO ₂	0.6	0.006	0.026
TOC	11	0.109	0.479
Methane	2.3	0.023	0.100
VOC	5.5	0.055	0.240
HAPS			
2-Methylnaphthalene	2.40E-05	2.39E-07	1.05E-06
Benzene	2.10E-03	2.09E-05	9.15E-05
Dichlorobenzene	1.20E-03	1.19E-05	5.23E-05
Fluoranthene	3.00E-06	2.98E-08	1.31E-07
Fluorene	2.80E-06	2.78E-08	1.22E-07
Formaldehyde	7.50E-02	7.46E-04	3.27E-03
Hexane	1.80E+00	1.79E-02	7.84E-02
Naphthalene	6.10E-04	6.07E-06	2.66E-05
Phenanthrene	1.70E-05	1.69E-07	7.40E-07
Toluene	3.40E-03	3.38E-05	1.48E-04

	lb/hr	tpy
TOTAL Uncontrolled VOC	0.128	0.559
TOTAL Uncontrolled HAPS	0.044	0.191
TOTAL Uncontrolled TAPs (Benzene)	4.87E-05	2.13E-04
TOTAL Uncontrolled Toluene	7.89E-05	3.45E-04
TOTAL Uncontrolled Hexane	0.042	0.183
TOTAL Uncontrolled TAPs (Formaldehyde)	0.002	0.008
TOTAL CH ₄	0.053	0.234
TOTAL CO _{2e} Emissions	2,800.55	12,266.40

Enter any notes here:

All Emission Factors based off AP-42 Sec 1.4 Natural Gas Combustion

Line Heater Emissions

Number of Units	8
Line Heater Rating (MMBtu/hr)	2.00
Operating hours/year	8760
Fuel Heat Value (Btu/scf)	1,206.8951

Pollutant	Emission Factors (lb/MMscf)	lb/hr	tpy
NOx	100	1.326	5.807
CO	84	1.114	4.878
CO ₂	120,000	1590.859	6967.963
Lead	0.0005	6.63E-06	2.90E-05
N ₂ O	2.2	0.029	0.128
PM (Total)	7.6	0.101	0.441
SO ₂	0.6	0.008	0.035
TOC	11	0.146	0.639
Methane	2.3	0.030	0.134
VOC	5.5	0.073	0.319
HAPS			
2-Methylnaphthalene	2.40E-05	3.18E-07	1.39E-06
Benzene	2.10E-03	2.78E-05	1.22E-04
Dichlorobenzene	1.20E-03	1.59E-05	6.97E-05
Fluoranthene	3.00E-06	3.98E-08	1.74E-07
Fluorene	2.80E-06	3.71E-08	1.63E-07
Formaldehyde	7.50E-02	9.94E-04	4.35E-03
Hexane	1.80E+00	2.39E-02	1.05E-01
Naphthalene	6.10E-04	8.09E-06	3.54E-05
Phenanthrene	1.70E-05	2.25E-07	9.87E-07
Toluene	3.40E-03	4.51E-05	1.97E-04

Table 10

**Enclosed Combustor Emissions
Addie Well Pad
Doddridge County, West Virginia
Antero Resources Corporation**

General Information	
Unit Name:	EC001, EC002, EC003

Pollutant	Emission Factor (lb/MMscf)
NOx	100
CO	84
PM10	7.6
PM2.5	5.7
SO ₂	0.6
CO ₂	120,000
VOC	5.5
benzene	2.10E-03
Hexane	1.80E+00
Toluene	3.40E-03
Formaldehyde	7.50E-02
N ₂ O	2.20
Lead	5.00E-04

Pollutant	Emission Factor ² (lb/MMBtu)
NO _x	0.068
CO	0.31

Constants	
Btu/MMBtu	1,000,000
scf/MMscf	1,000,000
lb/ton	2,000
H ₂ S molecular wei	34.08
SO ₂ molecular	64.06
seconds/hour	3,600
inches/ft	12

Destruction Efficiency	
VOC percent destruction efficiency (%)	98
H ₂ S percent destruction efficiency (%)	98

Enclosed Combustor operating hours	8760
No. of Enclosed Combustors	3
Maximum Design Heat Input Per Enclosed Combustor (MMBtu/hr)	12

Stream Information							
	1	2	3	4	5	6	Total
Stream Sent to Enclosed/Vapor Combustor (Enter Name of Each Stream Here)	pilot(s)	added fuel stream(s)	Oil Tank Flash Emissions	Water Tank Flash Emissions	Oil Tank W/B Emissions	Water Tank W/B Emissions	-
Maximum Expected Hourly Volumetric Flow Rate of Stream (scf/hr)	51	--	773.96	577.13	294.68	4.42	1,701.19
Maximum Expected Annual Volumetric Flow Rate of Stream (scf/yr)	446,760.00	--	6,779,859.19	5,055,616.70	2,581,439.13	38,726.35	14,902,401.36
Heating Content (Btu/ft3)	1,207		2,443.65	1,179.14	2,427.45	102.72	1,932.52

Mass Flow Rates of the Vapors Sent to this Control Device, Hourly Basis (lb/hr)							
	1	2	3	4	5	6	Total
Stream Sent to Enclosed Combustor/Vapor Combustor	pilot(s)	added fuel stream(s)	Oil Tank Flash Emissions	Water Tank Flash Emissions	Oil Tank W/B Emissions	Water Tank W/B Emissions	-
H2S	-	-	0.000	0.000	0.000	0.000	0.000
Total VOC	-	-	58.701	2.976	21.112	0.000	82.79
Benzene	-	-	0.017	0.009	0.004	0.000	0.030
Toluene	-	-	0.072	0.036	0.016	0.000	0.125
Ethylbenzene	-	-	0.034	0.016	0.008	0.000	0.058
Xylenes	-	-	0.077	0.038	0.016	0.000	0.131
n-Hexane	-	-	6.371	0.037	2.163	0.000	8.572
HAPs	-	-	6.572	0.137	2.206	0.000	8.914
Total Mass Flow	-	-	86.897	28.229	33.086	0.216	148.429
Mass Flow Rates of the Vapors Sent to this Control Device, Annual Basis (tpy)							
H2S	-	-	0.000	0.000	0.000	0.000	0.000
Total VOC	-	-	257.110	13.037	92.470	0.001	362.617
Benzene	-	-	0.074	0.040	0.016	0.000	0.130
Toluene	-	-	0.317	0.159	0.069	0.000	0.546
Ethylbenzene	-	-	0.147	0.072	0.034	0.000	0.253
Xylenes	-	-	0.339	0.165	0.069	0.000	0.572
n-Hexane	-	-	27.907	0.164	9.474	0.000	37.544
HAP	-	-	28.784	0.599	9.662	0.000	39.045
Total Mass Flow	-	-	380.609	123.644	144.917	0.947	650.118

Table 10

**Enclosed Combustor Emissions
Addie Well Pad
Doddridge County, West Virginia
Antero Resources Corporation**

Controlled Emissions							
Hourly (lb/hr)							
	1	2	3	4	5	6	Total
Stream Sent to Enclosed Combustor/Vapor Combustor	pilot(s)	added fuel stream(s)	Oil Tank Flash Emissions	Water Tank Flash Emissions	Oil Tank W/B Emissions	Water Tank W/B Emissions	-
NOx	0.005	-	2.448				2.45
CO	0.004	-	11.160				11.16
PM2.5	0.000	-	0.004	0.003	0.002	0.000	0.01
PM10	0.000	-	0.006	0.004	0.002	0.000	0.01
H2S	0.000	-	0.000	0.000	0.000	0.000	0.00
SO ₂	0.000	-	0.000	0.000	0.000	0.000	0.00
CO ₂	6.120	-	-	-	-	-	6.12
Total VOC	0.000	-	1.174	0.060	0.422	0.000	1.66
Benzene	0.000	-	0.000	0.000	0.000	0.000	0.00
Toluene	0.000	-	0.001	0.001	0.000	0.000	0.00
Ethylbenzene	0.000	-	0.001	0.000	0.000	0.000	0.00
Xylenes	0.000	-	0.002	0.001	0.000	0.000	0.00
n-Hexane	0.000	-	0.127	0.001	0.043	0.000	0.17
HAP	0.000	-	0.131	0.003	0.044	0.000	0.18
N ₂ O	0.000	-	0.002	0.001	0.001	0.000	0.00
Lead	0.000	-	0.000	0.000	0.000	0.000	0.00
Formaldehyde	0.000	-	-	-	-	-	0.00
Annual (tpy)							
	1	2	3	4	5	6	Total
Stream Sent to Enclosed Combustor/Vapor Combustor	pilot(s)	added fuel stream(s)	Oil Tank Flash Emissions	Water Tank Flash Emissions	Oil Tank W/B Emissions	Water Tank W/B Emissions	-
NOx	0.022	-	10.722				10.74
CO	0.019	-	48.881				48.90
PM2.5	0.001	-	0.019	0.014	0.007	0.000	0.04
PM10	0.002	-	0.026	0.019	0.010	0.000	0.06
H ₂ S	0.000	-	0.000	0.000	0.000	0.000	0.00
SO ₂	0.000	-	0.000	0.000	0.000	0.000	0.00
CO ₂	26.806	-	-	-	-	-	26.81
Total VOC	0.001	-	5.142	0.261	1.849	0.000	7.25
Benzene	0.000	-	0.001	0.001	0.000	0.000	0.00
Toluene	0.000	-	0.006	0.003	0.001	0.000	0.01
Ethylbenzene	0.000	-	0.003	0.001	0.001	0.000	0.01
Xylenes	0.000	-	0.007	0.003	0.001	0.000	0.01
n-Hexane	0.000	-	0.558	0.003	0.189	0.000	0.75
HAP	0.000	-	0.576	0.012	0.193	0.000	0.78
N ₂ O	0.000	-	0.007	0.006	0.003	0.000	0.02
Lead	0.000	-	0.000	0.000	0.000	0.000	0.00
Formaldehyde	0.000	-	-	-	-	-	0.00

Enclosed Combustor/Vapor Combustor Total Emissions		
	Hourly Emissions (lb/hr)	Annual Emissions (tpy)
Total VOC	1.66	7.25
NOx	2.453	10.745
CO	11.164	48.900
PM2.5	0.010	0.042
PM10	0.013	0.057
H ₂ S	1.63E-05	7.13E-05
SO ₂	3.06E-05	1.34E-04
Benzene (TAPs)	5.93E-04	2.60E-03
Toluene	2.49E-03	1.09E-02
Ethylbenzene	1.16E-03	5.06E-03
Xylenes	2.61E-03	0.011
Hexanes	0.172	0.751
Formaldehyde (TAPs)	3.83E-06	1.68E-05
HAPs	0.18	0.78
CH ₄	0.40	1.77
CO ₂ e	454.11	1989.02
N ₂ O	0.004	0.016
Lead	8.51E-07	3.73E-06

Enter any notes here as needed

1. Emission Factors from AP-42 Tables 1.4-1, 1.4-2, and 1.4.3
 2. Emission Factors from AP-42 Tables 13.5-1 and 13.5-2 for industrial flares

Table 11

**Enclosed Combustor GHG Emissions
Addie Well Pad
Doddridge County, West Virginia
Antero Resources Corporation**

Enclosed Combustor CO₂ and CH₄ Emissions

Components	Mole fraction of oil flash gas constituents ^a	Volume of oil flash gas sent to Enclosed Combustor <i>scf/year</i>	Mole fraction of water flash gas constituents ^a	Volume of water flash gas sent to Enclosed Combustor <i>scf/year</i>	Mole fraction of oil tank vapors constituents ^a	Volume of oil tank vapor sent to Enclosed Combustor <i>scf/year</i>	Mole fraction of water tank vapors constituents ^a	Volume of water tank vapors sent to Enclosed Combustor <i>scf/year</i>	Component volume of gas sent to Enclosed Combustor <i>scf/year</i>	Number of carbon atoms	Combustion Efficiency	Combusted CO ₂ Volume ^b <i>scf/year</i>	Uncombusted CO ₂ and CH ₄ Volume ^b <i>scf/year</i>	Volume GHGs Emitted <i>scf/year</i>
CO ₂	0.001	6,779,859	0.0154	5,055,617	0.0011	2,581,439	0.018	38,726	91,409	1	0	--	91,409	32,995,161
Methane	0.063	6,779,859	0.7360	5,055,617	0.0109	2,581,439	0.036	38,726	4,178,463	1	0.98	4,094,894	83,569	83,569
Ethane	0.428	6,779,859	0.1765	5,055,617	0.5065	2,581,439	0.010	38,726	5,099,783	2	0.98	9,995,575	--	
Propane	0.214	6,779,859	0.0189	5,055,617	0.2164	2,581,439	0.000	38,726	2,104,348	3	0.98	6,186,784	--	
i-Butane	0.059	6,779,859	0.0128	5,055,617	0.0570	2,581,439	0.000	38,726	610,808	4	0.98	2,394,368	--	
n-Butane	0.111	6,779,859	0.0057	5,055,617	0.1047	2,581,439	0.000	38,726	1,048,584	4	0.98	4,110,448	--	
Pentane	0.065	6,779,859	0.0015	5,055,617	0.0560	2,581,439	0.000	38,726	594,403	5	0.98	2,912,574	--	
Hexane	0.042	6,779,859	0.0005	5,055,617	0.0374	2,581,439	0.000	38,726	386,707	6	0.98	2,273,834	--	
Benzene	0.000	6,779,859	0.0001	5,055,617	0.0001	2,581,439	0.000	38,726	1,311	6	0.98	7,709	--	
Heptanes	0.008	6,779,859	0.0001	5,055,617	0.0054	2,581,439	0.000	38,726	69,988	7	0.98	480,119	--	
Toluene	0.000	6,779,859	0.0003	5,055,617	0.0002	2,581,439	0.000	38,726	4,664	7	0.98	31,997	--	
Octane	0.004	6,779,859	0.0001	5,055,617	0.0036	2,581,439	0.000	38,726	40,228	8	0.98	315,384	--	
Ethyl benzene	0.000	6,779,859	0.0001	5,055,617	0.0001	2,581,439	0.000	38,726	1,876	8	0.98	14,707	--	
Xylenes	0.000	6,779,859	0.0003	5,055,617	0.0002	2,581,439	0.000	38,726	4,244	8	0.98	33,272	--	
Nonane	0.000	6,779,859	0.0000	5,055,617	0.0004	2,581,439	0.000	38,726	4,312	9	0.98	38,029	--	
Decane plus	0.000	6,779,859	0.0000	5,055,617	0.0001	2,581,439	0.000	38,726	1,434	10	0.98	14,058	--	
Subtotal												32,903,752	--	

Pollutant	Volume Emitted <i>scf/year</i>	Density of GHG ^c <i>lb/scf</i>	Conversion Factor <i>lb/ton</i>	GWF	Emissions ^c	
					<i>lbs/hr</i>	<i>(tons/yr)</i>
CO ₂	32,995,161	0.12	2000	1	436.78	1,913.11
CH ₄	83,569	0.04	2000	25	0.40	1.77
CO₂e Emissions					446.9	1957.33

GHG Emissions Summary

Notes

a Flashing/Working/Breathing Losses from ProMax output reports

b 40 CFR 98.233 (n)(4): Eqns: W-19, W-20 and W-21

c 40 CFR 98.233(v) Eqn W-36 - density at 60° F and 14.7 psia

Table 12

**Haul Road Emissions
Addie Well Pad
Doddridge County, West Virginia
Antero Resources Corporation**

	PM	PM10
Particle Size Multiplier (k)	0.8	0.36
Silt Content of Road Surface Material (s) (%)	5.1	5.1
Days per Year with Precipitation > 0.01 in (p)	150	150
Control Efficiency for Watering ¹ (%)	50	50

Tanker Truck Trip Calculation	
Condensate Production (bbl/day)	1,147
PW Production (bbl/day)	4,000
Truck Capacity (bbl)	200

Pick Up Truck Trip Calculation	
No of Trips Per day	2
Trips Per Year	730

	# of Wheels	Mean Vehicle Weight (W) (tons)	Mean Vehicle Speed (S) (mph)	Miles Per Trip (miles)	Maximum Trips per Hour	Maximum Trips per Year	Vehicle Miles Travelled		PM	PM10
							(miles/hr)	(miles/year)	(lbs/VMT)	(lbs/VMT)
Tanker Trucks Condensate	10	40	10	0.3000	1	2094	0.3000	628.2000	3.8175	1.7179
Tanker Trucks PW	10	40	10	0.3000	1	7300	0.3000	2190.0000	3.8175	1.7179
Pick Up Truck	4	3	10	0.2000	1	730	0.2000	146.0000	0.3467	0.1560

	Uncontrolled Emissions						Controlled Emissions					
	(lbs/hr)	PM (lbs/year)	(tpy)	(lbs/hr)	PM10 (lbs/year)	(tpy)	(lbs/hr)	PM (lbs/year)	(tpy)	(lbs/hr)	PM10 (lbs/year)	(tpy)
Tanker Trucks Condensate	1.1453	2398.1720	1.1991	0.5154	1079.1774	0.5396	0.5726	1199.0860	0.5995	0.2577	539.5887	0.2698
Tanker Trucks PW	1.1453	8360.3894	4.1802	0.5154	3762.1752	1.8811	0.5726	4180.1947	2.0901	0.2577	1881.0876	0.9405
Pick Up Truck	0.0693	50.6152	0.0253	0.0312	22.7769	0.0114	0.0347	25.3076	0.0127	0.0156	11.3884	0.0057
Total Emissions	2.3599	10,809.1766	5.4046	1.0619	4,864.1295	2.4321	1.1799	5,404.5883	2.7023	0.5310	2,432.0647	1.2160

Enter any notes here:	1 EPA, AP-42, Volume I, Section 13.2.2 Unpaved Roads (11/06); assume 2:1 moisture ratio Section 13.2.2 Unpaved Roads (11/06) Source: Attachment L, Fugitive Emissions from Unpaved Haul Roads, Rev 03/2007, West Virginia Department of Environmental Protection
------------------------------	---

Table 13

Vapor Recovery Unit Emissions
 Addie Well Pad
 Doddridge County, West Virginia
 Antero Resources Corporation

Ford MSG425 2.5L Engine

Power (hp) ¹	76
Fuel consumption (lbs/BHP-hr) ¹	0.3864
Heat Content of Fuel (Btu/scf)	1206.8951
Density of NG (lb/scf)	0.056
Operating Hours/year	8760
No. of Engines	2

Ford CSG-637 3.7L Engine

Power (hp) ¹	110
Fuel consumption (lbs/BHP-hr) ¹	0.3584
Heat Content of Fuel (Btu/scf)	1206.8951
Density of NG (lb/scf)	0.056
Operating Hours/year	8760
No. of Engines	1

Pollutant	Emission Factors		lb/hr	tpy
	(g/hp-hr)	(lb/MMBtu)		
NOx ²	0.3731		0.1250	0.5477
CO ²	2.4627		0.8253	3.6146
CO ₂		110.000	139.2371	609.86
PM _{2.5}		9.500E-03	0.0120	0.0527
PM ₁₀		9.500E-03	0.0120	0.0527
PM (Total)		9.910E-03	0.0125	0.0549
SO ₂		5.880E-04	0.0007	0.0033
TOC		0.358	0.4532	1.9848
Methane		0.230	0.2911	1.2752
VOC ³		0.0296	0.0375	0.1641
HAPS				
Benzene		0.0016	0.0020	0.0088
Ethylbenzene		2.48E-05	3.14E-05	1.37E-04
Formaldehyde		0.0205	0.0259	0.1137
Naphthalene		9.71E-05	1.23E-04	0.0005
Toluene		5.58E-04	0.0007	0.0031
Xylene		1.95E-04	2.47E-04	0.0011

Pollutant	Emission Factors		lb/hr	tpy
	(g/hp-hr)	(lb/MMBtu)		
NOx ²	0.2985		0.0724	0.3171
CO ²	2.4627		0.5972	2.6158
CO ₂		110.000	93.4620	409.36
PM _{2.5}		9.500E-03	0.0081	0.0354
PM ₁₀		9.500E-03	0.0081	0.0354
PM (Total)		9.910E-03	0.0084	0.0369
SO ₂		5.880E-04	0.0005	0.0022
TOC		0.358	0.3042	1.3323
Methane		0.230	0.1954	0.8559
VOC ³		0.0296	0.0251	0.1102
HAPS				
Benzene		0.0016	0.0013	0.0059
Ethylbenzene		2.48E-05	2.11E-05	9.23E-05
Formaldehyde		0.0205	0.0174	0.0763
Naphthalene		9.71E-05	8.25E-05	3.61E-04
Toluene		5.58E-04	4.74E-04	0.0021
Xylene		1.95E-04	1.66E-04	0.0007

	lb/hr	tpy
TOTAL Uncontrolled VOC	0.0626	0.2743
TOTAL Uncontrolled NOx	0.1974	0.8647
TOTAL Uncontrolled HAPs	0.0486	0.2127
TOTAL Uncontrolled TAPs (Benzene)	0.0033	0.0146
TOTAL Uncontrolled Toluene	0.0012	0.0052
TOTAL Uncontrolled Ethylbenzene	0.0001	0.0002
TOTAL Uncontrolled Xylene	0.0004	0.0018
TOTAL Uncontrolled TAPs (Formaldehyde)	0.0434	0.1899
TOTAL CH ₄ Emissions	0.4866	2.1311
TOTAL CO _{2e} Emissions	244.8628	1072.4993

Enter Any Notes Here:

- Engines were manufactured in 2015 for MSG-425 and 2016 for CSG-637. Both engine ratings were taken from manufacturer engine specifications. Please see copies of manufacturer engine specifications in Appendix N.
- Emission factors used for the 76 HP engine NOx and CO emissions are certification levels indicated on MSG-425 CARB document. See MSG-425 CARB document in Appendix N. Emission factors used for the 110 HP engine NOx and CO emissions are certification levels indicated on CSG-637 CARB document. See CSG-637 CARB document in Appendix N.
- Emission factors for all other contaminants including VOCs were obtained from AP-42, Section 3.2 "Natural Gas-fired Reciprocating Engines", Table 3.2-3.
- Hours of operation was calculated based on the 100% operation of the VRU.



Bryan Research & Engineering, Inc.

ProMax[®] 3.2

with
TSWEET[®] & PROSIM[®]

Copyright © BRE Group, Ltd. 2002-2011. All Rights Reserved.

Simulation Report

Client Name:	Antero Resources
Location:	Doddridge County, WV
Job:	Addie Well Pad
Project Name:	Antero Promax Model- VRT
File Name:	\\det-s1.cra.int\Shared\AirQuality\ANTERO RESOURCES\ProMax\Antero WV_VRT\ProMax Model\Antero Promax Model- VRT.pmx
ProMax Version:	4.0.16071.0
Report Created:	1/24/2017 13:44

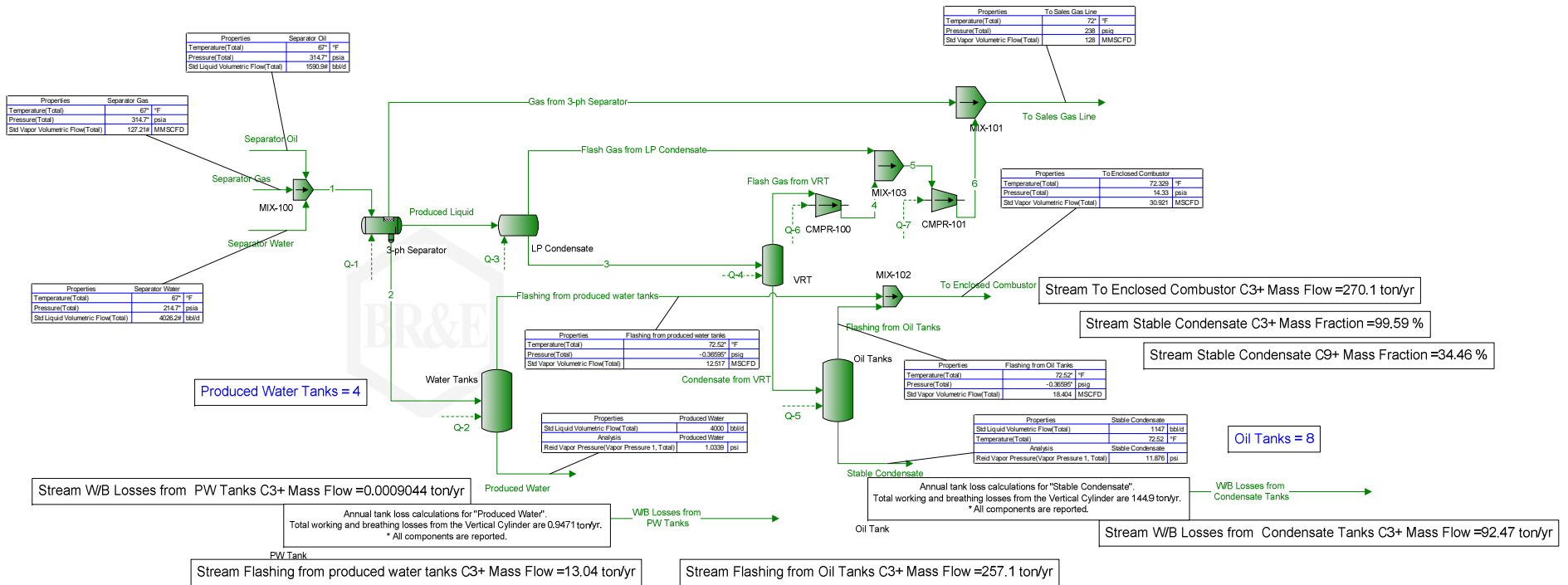

FESCO, Ltd.
1100 FESCO Avenue - Alice, Texas 78332

For: Antero Resources Appalachian Corp.
 1625 17th Street
 Denver, Colorado 80202

Sample: Central No. 2H (Jonathan Davis Well Pad)
 Separator Hydrocarbon Liquid
 Sampled @ 300 psig & 70 °F

Date Sampled: 09/20/13

Job Number: 35821.002

CHROMATOGRAPH EXTENDED ANALYSIS - GPA 2186-M

COMPONENT	MOL %	LIQ VOL %	WT %
Nitrogen	0.015	0.004	0.005
Carbon Dioxide	0.026	0.011	0.014
Methane	6.886	2.920	1.331
Ethane	8.322	5.569	3.014
Propane	8.761	6.040	4.653
Isobutane	2.532	2.073	1.772
n-Butane	7.165	5.652	5.015
2,2 Dimethylpropane	0.118	0.113	0.102
Isopentane	4.261	3.899	3.702
n-Pentane	5.583	5.064	4.851
2,2 Dimethylbutane	0.243	0.254	0.252
Cyclopentane	0.000	0.000	0.000
2,3 Dimethylbutane	0.401	0.411	0.416
2 Methylpentane	2.739	2.845	2.843
3 Methylpentane	1.887	1.927	1.958
n-Hexane	4.725	4.862	4.904
Heptanes Plus	<u>46.337</u>	<u>58.355</u>	<u>65.167</u>
Totals:	100.000	100.000	100.000

Characteristics of Heptanes Plus:

Specific Gravity ----- 0.7352 (Water=1)
 °API Gravity ----- 60.96 @ 60°F
 Molecular Weight ----- 116.8
 Vapor Volume ----- 19.98 CF/Gal
 Weight ----- 6.13 Lbs/Gal

Characteristics of Total Sample:

Specific Gravity ----- 0.6584 (Water=1)
 °API Gravity ----- 83.42 @ 60°F
 Molecular Weight ----- 83.0
 Vapor Volume ----- 25.17 CF/Gal
 Weight ----- 5.49 Lbs/Gal

Base Conditions: 14.850 PSI & 60 °F

Certified: FESCO, Ltd. - Alice, Texas

Analyst: XG
 Processor: JCdjv
 Cylinder ID: T-3044

 David Dannhaus 361-661-7015

TANKS DATA INPUT REPORT

COMPONENT	Mol %	LiqVol %	Wt %
Carbon Dioxide	0.026	0.011	0.014
Nitrogen	0.015	0.004	0.005
Methane	6.886	2.920	1.331
Ethane	8.322	5.569	3.014
Propane	8.761	6.040	4.653
Isobutane	2.532	2.073	1.772
n-Butane	7.282	5.765	5.118
Isopentane	4.261	3.899	3.702
n-Pentane	5.583	5.064	4.851
Other C-6's	5.270	5.438	5.470
Heptanes	12.718	14.211	15.025
Octanes	14.320	17.030	18.719
Nonanes	6.129	8.438	9.360
Decanes Plus	9.786	15.535	17.888
Benzene	0.097	0.068	0.091
Toluene	0.708	0.593	0.786
E-Benzene	0.715	0.690	0.914
Xylenes	1.865	1.790	2.384
n-Hexane	4.725	4.862	4.904
2,2,4 Trimethylpentane	<u>0.000</u>	<u>0.000</u>	<u>0.000</u>
Totals:	100.000	100.000	100.000

Characteristics of Total Sample:

Specific Gravity -----	0.6584 (Water=1)
°API Gravity -----	83.42 @ 60°F
Molecular Weight-----	83.0
Vapor Volume -----	25.17 CF/Gal
Weight -----	5.49 Lbs/Gal

Characteristics of Decanes (C10) Plus:

Specific Gravity -----	0.7581 (Water=1)
Molecular Weight-----	151.8

Characteristics of Atmospheric Sample:

°API Gravity -----	68.98 @ 60°F
Reid Vapor Pressure (ASTM D-5191)-----	4.41 psi

QUALITY CONTROL CHECK			
	Sampling Conditions	Test Samples	
Cylinder Number	-----	T-3044*	T-1105
Pressure, PSIG	300	246	238
Temperature, °F	70	70	70

* Sample used for analysis

TOTAL EXTENDED REPORT

COMPONENT	Mol %	LiqVol %	Wt %
Nitrogen	0.015	0.004	0.005
Carbon Dioxide	0.026	0.011	0.014
Methane	6.886	2.920	1.331
Ethane	8.322	5.569	3.014
Propane	8.761	6.040	4.653
Isobutane	2.532	2.073	1.772
n-Butane	7.165	5.652	5.015
2,2 Dimethylpropane	0.118	0.113	0.102
Isopentane	4.261	3.899	3.702
n-Pentane	5.583	5.064	4.851
2,2 Dimethylbutane	0.243	0.254	0.252
Cyclopentane	0.000	0.000	0.000
2,3 Dimethylbutane	0.401	0.411	0.416
2 Methylpentane	2.739	2.845	2.843
3 Methylpentane	1.887	1.927	1.958
n-Hexane	4.725	4.862	4.904
Methylcyclopentane	0.750	0.664	0.760
Benzene	0.097	0.068	0.091
Cyclohexane	0.855	0.728	0.866
2-Methylhexane	3.019	3.512	3.643
3-Methylhexane	2.570	2.952	3.101
2,2,4 Trimethylpentane	0.000	0.000	0.000
Other C-7's	1.170	1.328	1.398
n-Heptane	4.355	5.028	5.256
Methylcyclohexane	3.005	3.023	3.554
Toluene	0.708	0.593	0.786
Other C-8's	8.306	10.150	11.026
n-Octane	3.008	3.857	4.139
E-Benzene	0.715	0.690	0.914
M & P Xylenes	0.802	0.779	1.026
O-Xylene	1.062	1.011	1.358
Other C-9's	4.456	6.081	6.775
n-Nonane	1.673	2.356	2.585
Other C-10's	3.766	5.649	6.408
n-decane	0.826	1.268	1.415
Undecanes(11)	2.552	3.927	4.518
Dodecanes(12)	1.336	2.221	2.591
Tridecanes(13)	0.741	1.321	1.563
Tetradecanes(14)	0.329	0.627	0.752
Pentadecanes(15)	0.124	0.253	0.307
Hexadecanes(16)	0.056	0.123	0.151
Heptadecanes(17)	0.026	0.061	0.075
Octadecanes(18)	0.012	0.028	0.035
Nonadecanes(19)	0.006	0.015	0.019
Eicosanes(20)	0.002	0.005	0.006
Heneicosanes(21)	0.001	0.003	0.004
Docosanes(22)	0.001	0.002	0.002
Tricosanes(23)	0.000	0.001	0.002
Tetracosanes(24)	0.000	0.001	0.001
Pentacosanes(25)	0.000	0.001	0.001
Hexacosanes(26)	0.000	0.001	0.001
Heptacosanes(27)	0.000	0.001	0.001
Octacosanes(28)	0.000	0.001	0.001
Nonacosanes(29)	0.000	0.001	0.002
Triacotanes(30)	0.001	0.002	0.003
Hentriacotanes Plus(31+)	<u>0.005</u>	<u>0.022</u>	<u>0.031</u>
Total	100.000	100.000	100.000



FESCO, Ltd.
1100 Fesco Avenue - Alice, Texas 78332

For: Antero Resources Appalachian Corp.
 1625 17th Street
 Denver, Colorado 80202

Date Sampled: 09/20/13

Date Analyzed: 10/02/13

Sample: Central No. 2H (Jonathan Davis Well Pad)

Job Number: J35821

FLASH LIBERATION OF HYDROCARBON LIQUID		
	Separator HC Liquid	Stock Tank
Pressure, psig	300	0
Temperature, °F	70	70
Gas Oil Ratio (1)	-----	365
Gas Specific Gravity (2)	-----	1.408
Separator Volume Factor (3)	1.2406	1.000

STOCK TANK FLUID PROPERTIES	
Shrinkage Recovery Factor (4)	0.8060
Oil API Gravity at 60 °F	68.98
Reid Vapor Pressure, psi (5)	4.41

Quality Control Check			
	Sampling Conditions	Test Samples	
Cylinder No.	-----	T-3044*	T-1105
Pressure, psig	300	246	238
Temperature, °F	70	70	70

(1) - Scf of flashed vapor per barrel of stock tank oil

(2) - Air = 1.000

(3) - Separator volume / Stock tank volume

(4) - Fraction of first stage separator liquid

(5) - Absolute pressure at 100 deg F

Analyst: _____ M. G. _____

* Sample used for flash study

Base Conditions: 14.85 PSI & 60 °F

Certified: FESCO, Ltd. - Alice, Texas

 David Dannhaus 361-661-7015

FESCO, Ltd.
1100 Fesco Ave. - Alice, Texas 78332

For: Antero Resources Appalachian Corp.
 1625 17th Street
 Denver, Colorado 80202

Sample: Central No. 2H (Jonathan Davis Well Pad)
 Gas Evolved from Hydrocarbon Liquid Flashed
 From 300 psig & 70 °F to 0 psig & 70 °F

Date Sampled: 09/20/13

Job Number: 35821.001

CHROMATOGRAPH EXTENDED ANALYSIS - SUMMATION REPORT

COMPONENT	MOL%	GPM
Hydrogen Sulfide*	< 0.001	
Nitrogen	0.053	
Carbon Dioxide	0.107	
Methane	23.624	
Ethane	26.392	7.114
Propane	22.728	6.311
Isobutane	4.750	1.567
n-Butane	10.798	3.431
2-2 Dimethylpropane	0.127	0.049
Isopentane	3.304	1.218
n-Pentane	3.382	1.236
Hexanes	2.805	1.165
Heptanes Plus	<u>1.930</u>	<u>0.855</u>
Totals	100.000	22.945

Computed Real Characteristics Of Heptanes Plus:

Specific Gravity ----- 3.556 (Air=1)
 Molecular Weight ----- 101.39
 Gross Heating Value ----- 5420 BTU/CF

Computed Real Characteristics Of Total Sample:

Specific Gravity ----- 1.408 (Air=1)
 Compressibility (Z) ----- 0.9845
 Molecular Weight ----- 40.14
 Gross Heating Value
 Dry Basis ----- 2354 BTU/CF
 Saturated Basis ----- 2314 BTU/CF

*Hydrogen Sulfide tested in laboratory by: Stained Tube Method (GPA 2377)

Results: <0.013 Gr/100 CF, <0.2 PPMV or <0.001 Mol %

Base Conditions: 14.850 PSI & 60 Deg F

Certified: FESCO, Ltd. - Alice, Texas

Analyst: MR
 Processor: ANB
 Cylinder ID: CYL-1

David Dannhaus 361-661-7015

**CHROMATOGRAPH EXTENDED ANALYSIS
TOTAL REPORT**

COMPONENT	MOL %	GPM	WT %
Hydrogen Sulfide*	< 0.001		< 0.001
Nitrogen	0.053		0.037
Carbon Dioxide	0.107		0.117
Methane	23.624		9.441
Ethane	26.392	7.114	19.772
Propane	22.728	6.311	24.970
Isobutane	4.750	1.567	6.879
n-Butane	10.798	3.431	15.637
2,2 Dimethylpropane	0.127	0.049	0.228
Isopentane	3.304	1.218	5.939
n-Pentane	3.382	1.236	6.080
2,2 Dimethylbutane	0.117	0.049	0.251
Cyclopentane	0.000	0.000	0.000
2,3 Dimethylbutane	0.166	0.069	0.356
2 Methylpentane	0.881	0.369	1.892
3 Methylpentane	0.543	0.223	1.166
n-Hexane	1.098	0.455	2.358
Methylcyclopentane	0.079	0.027	0.166
Benzene	0.022	0.006	0.043
Cyclohexane	0.125	0.043	0.262
2-Methylhexane	0.233	0.109	0.582
3-Methylhexane	0.233	0.107	0.582
2,2,4 Trimethylpentane	0.000	0.000	0.000
Other C7's	0.228	0.100	0.564
n-Heptane	0.296	0.138	0.739
Methylcyclohexane	0.195	0.079	0.477
Toluene	0.043	0.015	0.099
Other C8's	0.271	0.127	0.744
n-Octane	0.068	0.035	0.194
Ethylbenzene	0.002	0.001	0.005
M & P Xylenes	0.022	0.009	0.058
O-Xylene	0.003	0.001	0.008
Other C9's	0.076	0.039	0.239
n-Nonane	0.014	0.008	0.045
Other C10's	0.018	0.011	0.063
n-Decane	0.002	0.001	0.007
Undecanes (11)	<u>0.000</u>	<u>0.000</u>	<u>0.000</u>
Totals	100.000	22.945	100.000

Computed Real Characteristics Of Total Sample:

Specific Gravity -----	1.408	(Air=1)
Compressibility (Z) -----	0.9845	
Molecular Weight -----	40.14	
Gross Heating Value		
Dry Basis -----	2354	BTU/CF
Saturated Basis -----	2314	BTU/CF

Gas Analytical

Report Date: Jun 8, 2016 8:11a

Client:	Antero Resources	Date Sampled:	Jun 3, 2016
Client Code:	9569	Analysis Date:	Jun 6, 2016 11:57a
Site:	Hiley Unit 2H	Collected By:	Doug Lipscomb
Field No:	9998	Date Effective:	Jun 3, 2016 12:00a
Meter:		Sample Pressure (PSI):	201.4
Source Laboratory	Clarksburg (Bridgeport), WV	Sample Temp (°F):	63
Lab File No:	X_CH1-12112.CHR	Field H2O:	No Test
Sample Type:	Spot	Field H2S:	No Test
Reviewed By:			
Analysis Status:	good		

Component	Mol %	Gal/MSCF
Methane	80.8909	
Ethane	14.3137	3.8050
Propane	2.2213	0.6106
I-Butane	0.4547	0.1485
N-Butane	0.7773	0.2446
I-Pentane	0.2153	0.0786
N-Pentane	0.1929	0.0698
Nitrogen	0.4085	
Oxygen	<MDL	
Carbon Dioxide	0.1743	
Hexanes+	0.3511	0.1442
TOTAL	100.0000	5.1014

Analytical Results at Base Conditions (Real)	
BTU/SCF (Dry):	1,206.8951 BTU/ft ³
BTU/SCF (Saturated):	1,186.7210 BTU/ft ³
PSIA:	14.696 PSI
Temperature (°F):	60.0 °F
Z Factor (Dry):	0.99683
Z Factor (Saturated):	0.99643

Analytical Results at Contract Conditions (Real)	
BTU/SCF (Dry):	1,206.9040 BTU/ft ³
BTU/SCF (Saturated):	1,186.7763 BTU/ft ³
PSIA:	14.730 PSI
Temperature (°F):	60.0 °F
Z Factor (Dry):	0.99682
Z Factor (Saturated):	0.99643

Calculated Specific Gravities		
Ideal Gravity:	0.6833	Real Gravity: 0.6852
Molecular Wt:	19.7893	lb/lbmol

Gross Heating Values are Based on:
GPA 2145-09, 2172
Compressibility is Calculated using AGA-8.

Source	Date	Notes

Attachment U

Facility-wide Emissions Summary Sheet(s)

ATTACHMENT U – FACILITY-WIDE CONTROLLED EMISSIONS SUMMARY SHEET

List all sources of emissions in this table. Use extra pages if necessary.

Emission Point ID#	NOx		CO		VOC		SO2		PM10		PM2.5		CH ₄		GHG (CO ₂ e)	
	lb/hr	tpy	lb/hr	tpy	lb/hr	tpy	lb/hr	tpy	lb/hr	tpy	lb/hr	tpy	lb/hr	tpy	lb/hr	tpy
EP-HR001									0.5310	1.2160						
EP-PCV					0.0532	0.2329							0.3009	1.3179	7.5239	32.9545
F001					2.6880	11.7736							2.8523	12.4930	71.3072	312.3257
EP-L001					11.8212	10.3104							0.0757	0.0661	1.9146	1.6699
EP-L002					1.14E-03	3.46E-03							0.0371	0.1128	0.9791	2.9782
EP-ENG001-002 (emissions per EPN)	0.0625	0.2738	0.4126	1.8073	0.0187	0.0821	0.0004	0.0016	0.0060	0.0263	0.0060	0.0263	0.1456	0.6376	73.2577	320.8687
EP-ENG003 (emissions per EPN)	0.0724	0.3171	0.5972	2.6158	0.0251	0.1102	0.0005	0.0022	0.0081	0.0354	0.0081	0.0354	0.1954	0.8559	98.3475	430.7619
EP-GPU001-008 (emissions per EPN)	0.1243	0.5444	0.1044	0.4573	0.0068	0.0299	0.0007	0.0033	0.0094	0.0414	0.0094	0.0414	0.0029	0.0125	149.1430	653.2465
EP-LH001 -008 (emissions per EPN)	0.1657	0.7258	0.1392	0.6097	0.0091	0.0399	0.0010	0.0044	0.0126	0.0552	0.0126	0.0552	0.0038	0.0167	198.8574	870.9953
EP-EC001 -003 (emissions per EPN)	0.8177	3.5815	3.7214	16.2999	0.5520	2.4179	0.0000	0.0000	0.0043	0.0189	0.0032	0.0142	0.1346	0.5896	151.3712	663.0058
TOTAL	4.9705	21.7709	14.5356	63.6658	1.8463	18.4006	0.0152	0.0666	0.2093	0.9169	0.2061	0.9028	0.9438	4.3129	3482.9798	15260.0995

Annual emissions shall be based on 8760 hours per year of operation for all emission units except emergency generators.

According to 45CSR14 Section 2.43.e, fugitive emissions are not included in the major source determination because it is not listed as one of the source categories in Table 1. Therefore, fugitive emissions shall not be included in the PTE above

ATTACHMENT U – FACILITY-WIDE CONTROLLED EMISSIONS SUMMARY SHEET

List all sources of emissions in this table. Use extra pages if necessary.

Emission Point ID#	Formaldehyde		Benzene		Toluene		Ethylbenzene		Xylenes		Hexane		Total HAPs	
	lb/hr	tpy	lb/hr	tpy	lb/hr	tpy	lb/hr	tpy	lb/hr	tpy	lb/hr	tpy	lb/hr	tpy
EP-HR001														
EP-PCV			0.00E+00	0.00E+00	0.00E+00	0.00E+00	0.00E+00	0.00E+00	0.00E+00	0.00E+00	0.0070	0.0307	0.0070	0.0307
F001			0.0021	0.0091	0.0178	0.0781	0.0208	0.0909	0.0541	0.2370	0.2124	0.9305	0.3072	1.3456
EP-L001			2.04E-03	1.78E-03	8.85E-03	7.72E-03	4.39E-03	3.83E-03	0.009	7.69E-03	1.211	1.056	1.235	1.077
EP-L002			5.92E-06	1.80E-05	5.16E-06	1.57E-05	7.07E-07	2.15E-06	1.33E-06	4.05E-06	5.26E-08	1.60E-07	1.32E-05	4.01E-05
EP-ENG001-002(emissions per EPN)	0.0130	0.0568	0.0010	0.0044	0.0004	0.0015	1.57E-05	6.87E-05	0.0001	0.0005			0.0145	0.0636
EP-ENG003(emissions per EPN)	0.0174	0.0763	0.0013	0.0059	0.0005	0.0021	2.11E-05	9.23E-05	0.0002	0.0007			0.0195	0.0854
EP-GPU001-008 (emissions per EPN)	0.0001	0.0004	2.61E-06	1.14E-05	4.23E-06	1.85E-05			0.00E+00	0.00E+00	0.0022	0.0098	0.0023	0.0102
EP-LH001 -008 (emissions per EPN)	0.0001	0.0005	3.48E-06	1.52E-05	5.63E-06	2.47E-05			0.00E+00	0.00E+00	0.0030	0.0131	0.0031	0.0137
EP-EC001 -003 (emissions per EPN)	1.28E-06	5.58E-06	0.0002	0.0009	0.0008	0.0036	0.0004	0.0017	0.0009	0.0038	0.0572	0.2504	0.0595	0.2604
TOTAL	0.0451	0.1976	0.0040	0.0192	0.0038	0.0242	0.0012	0.0091	0.0030	0.0210	0.2133	1.9905	0.2706	2.2627

Annual emissions shall be based on 8760 hours per year of operation for all emission units except emergency generators.

According to 45CSR14 Section 2.43.e, fugitive emissions are not included in the major source determination because it is not listed as one of the source categories in Table 1. Therefore, fugitive emissions shall not be included in the PTE above

Attachment V Class I Legal Advertisement

Attachment V

**Air Quality Permit Notice
Notice of Application
Addie Well Pad
Antero Resources Corporation
Doddridge County, West Virginia**

Notice is given that Antero Resources Corporation has applied to the West Virginia Department of Environmental Protection, Division of Air Quality, for a G70-D General Permit Registration for an Oil and Natural Gas Production facility located at 8 Slaughter Run West Union, WV 26456, in Doddridge County, West Virginia.

The latitude and longitude coordinates are: 39.333523 and -80.805677

The applicant estimates the potential to discharge the following Regulated Air Pollutants will be:

Pollutants	TOTALS (tpy):
NO _x	21.7709
CO	63.6658
PM _{2.5}	0.9028
PM ₁₀	0.9169
VOC	18.4006
SO ₂	0.0666
CO _{2e}	15260.0995
CH ₄	4.3129
Formaldehyde	0.1976
Benzene	0.0192
Toluene	0.0242
Ethylbenzene	0.0091
Xylenes	0.0210
Hexane	1.9905
Total HAPs	2.2627

Proposed new equipment will be installed by December 01, 2017 and the facility is expected to begin the operations by June 01, 2018. Written comments will be received by the West Virginia Department of Environmental Protection, Division of Air Quality, 601 57th Street, SE, Charleston, WV 25304, for at least 30 calendar days from the date of publication of this notice.

Any questions regarding this permit application should be directed to the DAQ at (304) 926-0499, extension 1250, during normal business hours.

Dated this the ___ day of _____, 2017

By: Antero Resources Corporation
Barry Schatz
Senior Environmental & Regulatory Manager
1615 Wynkoop Street
Denver, CO 80202

www.ghd.com

