



Appalachia Midstream Services, LLC
100 Teletech Drive, Suite 2
Moundsville, WV 26041-2352

February 2, 2018
(Via Federal Express)

Beverly D. McKeone
New Source Review Program Manager
Division of Air Quality
West Virginia Department of Environmental Protection
601 57th Street SE
Charleston, WV 25304-2345

**Subject: Application for 45CSR13 NSR Permit Modification
Appalachia Midstream Services, LLC (AMS)
Battle Run Compressor Station (BRCS)
Permit No. R13-2916A - Plant ID No 069-00107
Ohio County, West Virginia**

Dear Ms. McKeone:

Appalachia Midstream Services, LLC (AMS) is submitting one (1) original paper copy and two (2) CD-ROMs of an Application for 45CSR13 New Source Review (NSR) Permit Modification for the existing Battle Run Compressor Station (BRCS), located at 297 Windmill Truckers Rd, Valley Grove, in Ohio County, West Virginia.

This application for Permit Modification has been prepared and submitted as the previous application, and consequentially the current permit, did not include all potential emission sources at the facility.

The most significant changes to the potential to emit (PTE) are the results of:

- 1) The previous application did not include the Compressor Rod Packing (CRP) emissions. **(Increases the VOC point source emission estimate by 47.00 tpy.)**
- 2) The previous application used less conservative parameters and assumptions for estimating the Dehydrator (DHY-01 thru DHY-03) emissions. **(Increases the VOC point source emission estimate by 6.90 tpy per dehydrator and by 20.70 tpy for all three dehydrators.)**
- 3) The previous application used less conservative parameters and assumptions for estimating the Compressor Blowdown (CBD) and did not include the Emergency Shutdown (ESD) Testing emissions. **(Increases the VOC point source emission estimate by 17.97 tpy.)**
- 4) The previous application used less conservative parameters and assumptions for estimating the Piping and Equipment Leak (FUG-G, FUG-O) emissions and did not include the Engine Crankcase (ECC) emissions. **(Increases the VOC fugitive source emission estimate by 45.09 tpy.)**

These changes, and other less substantial changes, are summarized on the following page:

Appalachia Midstream Services, LLC (AMS)
Battle Run Compressor Station (BRCS)
 Application for 45CSR13 New Source Review Permit Modification (NSR)
Comparison: "Current" Permit (R13-2916A - 03/13/13) vs. "New" Permit (R13-2916B) Application

Source ID	Description	NO _x		CO		VOC		PM		SO ₂		HCHO		TOT HAPs		CO _{2e}	
		"Current"	"New"	"Current"	"New"	"Current"	"New"	"Current"	"New"	"Current"	"New"	"Current"	"New"	"Current"	"New"	"Current"	"New"
Battle Run Compressor Station (BRCS) - Point Sources																	
CE-01	Compressor Engine 01 - CAT G3516B (OxCat)	6.66	6.66	6.20	3.04	3.38	0.49	0.03	0.03	0.03	0.27	0.48	1.25	0.67	7.095	8.563	
CE-02	Compressor Engine 02 - CAT G3516B (OxCat)	6.66	6.66	6.20	3.04	3.38	0.54	0.03	0.03	0.03	0.27	0.48	1.25	0.67	7.095	8.563	
CE-03	Compressor Engine 03 - CAT G3516B (OxCat)	6.66	6.66	6.20	3.04	3.38	0.54	0.03	0.03	0.03	0.27	0.48	1.25	0.67	7.095	8.563	
CE-04	Compressor Engine 04 - CAT G3516B (OxCat)	6.66	6.66	6.20	3.04	3.38	0.54	0.03	0.03	0.03	0.27	0.48	1.25	0.67	7.095	8.563	
CE-05	Compressor Engine 05 - CAT G3516B (OxCat)	6.66	6.66	6.20	3.04	3.38	0.54	0.03	0.03	0.03	0.27	0.48	1.25	0.67	7.095	8.563	
CE-06	Compressor Engine 06 - CAT G3516B (OxCat)	6.66	6.66	6.20	3.04	3.38	0.54	0.03	0.03	0.03	0.27	0.48	1.25	0.67	7.095	8.563	
CE-07	Compressor Engine 07 - CAT G3516B (OxCat)	6.66	6.66	6.20	3.04	3.38	0.54	0.03	0.03	0.03	0.27	0.48	1.25	0.67	7.095	8.563	
CE-08	Compressor Engine 08 - CAT G3516B (OxCat)	6.66	6.66	6.20	3.04	3.38	0.54	0.03	0.03	0.03	0.27	0.48	1.25	0.67	7.095	8.563	
CE-09	Compressor Engine 09 - CAT G3516B (OxCat)	6.66	6.66	6.20	3.04	3.38	0.54	0.03	0.03	0.03	0.27	0.48	1.25	0.67	7.095	8.563	
CE-10	Compressor Engine 10 - CAT G3516B (OxCat)	6.66	6.66	6.20	3.04	3.38	0.54	0.03	0.03	0.03	0.27	0.48	1.25	0.67	7.095	8.563	
CE-11	Compressor Engine 11 - CAT G3516B (OxCat)	6.66	6.66	6.20	3.04	3.38	0.54	0.03	0.03	0.03	0.27	0.48	1.25	0.67	7.095	8.563	
CE-12	Compressor Engine 12 - CAT G3516B (OxCat)	6.66	6.66	6.20	3.04	3.38	0.54	0.03	0.03	0.03	0.27	0.48	1.25	0.67	7.095	8.563	
CRP	Compressor Rod Packing					47.00								1.52		2.445	
GEN	Generator Engine - Baldor IGLC420-2N (NSCR)	5.84	5.84	11.68	4.09	4.60	0.48	0.39	0.01	0.01	0.51	0.51	0.70	0.75	2.900	2.298	
DHY-01	Dehydrator 01 (BTEX Buster)				1.39	8.29							0.05	1.34	3	12.00	
DHY-02	Dehydrator 02 (BTEX Buster)				1.39	8.29							0.05	1.34	3	12.00	
DHY-03	Dehydrator 03 (BTEX Buster)				1.39	8.29							0.05	1.34	3	12.00	
BLR-01	Reboiler 01	0.33	0.43	0.28	0.36	0.02	0.02	0.03	3E-03	3E-03	3E-04	3E-04	0.01	0.01	512	518	
BLR-02	Reboiler 02	0.33	0.43	0.28	0.36	0.02	0.02	0.03	3E-03	3E-03	3E-04	3E-04	0.01	0.01	512	518	
BLR-03	Reboiler 03	0.33	0.43	0.28	0.36	0.02	0.02	0.03	3E-03	3E-03	3E-04	3E-04	0.01	0.01	512	518	
HTR-01	Heater-Treater Burner 01	0.16	0.21	0.14	0.18	0.01	0.01	0.02	1E-03	1E-03	2E-04	2E-04	4E-03	4E-03	256	259	
HTR-02	Heater-Treater Burner 02	0.16	0.21	0.14	0.18	0.01	0.01	0.02	1E-03	1E-03	2E-04	2E-04	4E-03	4E-03	256	259	
TK-01	Storage Tank 01 - Stabilized Condensate (SC) (VRU)					1.53	0.17						0.08	0.05	58		
TK-02	Storage Tank 02 - Stabilized Condensate (SC) (VRU)					1.53	0.17						0.08	0.05	58		
TK-03	Storage Tank 03 - Stabilized Condensate (SC) (VRU)					1.53	0.17						0.08	0.05	58		
TK-04	Storage Tank 04 - Stabilized Condensate (SC) (VRU)					1.53	0.17						0.08	0.05	58		
TK-05	Storage Tank 05 - Stabilized Condensate (SC) (VRU)					1.53	0.17						0.08	0.05	58		
TK-06	Storage Tank 06 - Stabilized Condensate (SC) (VRU)					1.53	0.17						0.08	0.05	58		
TK-07	Storage Tank 07 - Stabilized Condensate (SC) (VRU)					1.53	0.17						0.08	0.05	58		
TK-08	Storage Tank 08 - Stabilized Condensate (SC) (VRU)					1.53	0.17						0.08	0.05	58		
WTK-01	Storage Tank W01 - Produced Water (PW)					0.90	0.03						0.05	0.01	36		
WTK-02	Storage Tank W02 - Produced Water (PW)					0.90	0.03						0.05	0.01	36		
TLO	Truck Loading - Stabilized Condensate (SC) (CarbCan)					8.15	8.52						0.41	2.56	53		
WTLO	Truck Loading - Produced Water (PW)					9.14	27.11						0.01	0.02	0.08		
CBD/ESD	Compressor Blowdown/Emergency Shutdown Tests												0.16	0.88	605	1,410	
PIG	Pigging Operations															214	
Battle Run Compressor Station (BRCS) - Point Sources		87.10	87.51	22.72	87.48	76.16	158.43	7.05	6.41	0.40	0.37	3.71	6.27	17.16	18.37	91,298	111,233
Battle Run Compressor Station (BRCS) - Fugitives																	
FUG-G	Piping & Equip Leaks - Gas					8.78	21.61						0.22	0.70	584	1,124	
FUG-O	Piping & Equip Leaks - Light Liquid					1.01	32.68							1.06		0	
ECC	Engine Crankcase Fugitives		0.21		1.28		0.60		0.02		9E-04		0.15	0.18		265	
Battle Run Compressor Station (BRCS) - Fugitives			0.21		1.28	9.79	54.88		0.02		9E-04		0.15	0.22	1.94	584	1,389
Battle Run Compressor Station (BRCS) - Total		87.10	87.72	22.72	88.76	85.95	213.31	7.05	6.43	0.40	0.37	3.71	6.42	17.38	20.30	91,882	112,622
Increase/(Decrease):		0.62		66.05		127.36		(0.62)		(0.03)		2.71		2.92		20,740	

The revised VOC PTE is greater than the Title V Major Source Threshold. Accordingly, Appalachia Midstream Services, LLC will prepare and submit a Title V Operating Permit application in the first quarter of 2018.

Appalachia Midstream Services, LLC (AMS)
Battle Run Compressor Station (BRCS)
 Application for 45CSR13 New Source Review Permit Modification (NSR)

EMISSIONS SUMMARY

Facility-Wide Emissions Summary [Tons per Year]			
Criteria Pollutants	Potential Emissions (Including Fugitives)		
	R13-2916A	CHANGE	R13-2916B (Proposed)
Nitrogen Oxides (NOX)	87.10	0.62	87.72
Carbon Monoxide (CO)	22.72	66.05	88.76
Volatile Organic Compounds (VOC)	85.95	127.36	213.31
Particulate Matter (PM10/2.5)	7.05	(0.62)	6.43
Sulfur Dioxide (SO2)	0.40	(0.03)	0.37
Hazardous Air Pollutants	Potential Emissions (Including Fugitives)		
	R13-2916A	CHANGE	R13-2916B (Proposed)
Acetaldehyde	5.50	(4.44)	1.06
Acrolein	3.40	(2.73)	0.67
Benzene	0.37	0.99	1.36
Butadiene, 1,3-	---	0.05	0.05
Ethylbenzene	0.08	0.39	0.47
Formaldehyde (HCHO)	3.71	2.71	6.42
n-Hexane	---	6.73	6.73
Methanol (MeOH)	1.94	(1.58)	0.36
Polycyclic Organic Matter (POM)	1.62	(1.58)	0.04
Toluene	0.38	1.31	1.69
2,2,4-Trimethylpentane (TMP)	---	0.47	0.47
Xylenes	0.36	0.59	0.95
Other/Trace HAP*	---	0.04	0.04
Total Hazardous Air Pollutants (HAPs)	17.38	2.92	20.30
Other Regulated Pollutants (Other than Criteria and HAP)	Potential Emissions (Including Fugitives)		
	R13-2916A	CHANGE	R13-2916B (Proposed)
Carbon Dioxide (CO ₂)	90,016	(1,274)	88,742
Methane (CH ₄)	86.62	867	953
Nitrous Oxide (N ₂ O)	0.15	0.02	0.17
CO ₂ equivalent (CO ₂ e)	91,882	20,740	112,622

*Other/Trace HAPs include: Carbon Tetrachloride, Chlorobenzene, Chloroform, Dichloropropene, 1,3-Dichloropropene, Ethylene Dibromide, Methylene Chloride, Phenol, Propylene Oxide, Styrene, 1,1,2,2-Tetrachloroethane, 1,1,2-Trichloroethane, and Vinyl Chloride (as per AP-42).

Beverly McKeone
WVDEP – Division of Air Quality
February 2, 2018
Page 04 of 04

This application is prepared and submitted to request modifications to the facility's potential-to-emit (PTE). Although these modifications are significant, the only physical or operational changes proposed are:

- Remove the requirements to control the Produced Water (PW) Storage Tank (WTK-01 and WTK-02) and the Produced Water (PW) Truck Load-Out (WTLO) emissions. (The combined uncontrolled VOC emissions from WTK and WTLO operations is estimated at 0.14 tpy.)

Proposed modifications to current permit (R13-2916A) are provided in Attachment L – Emission Unit Data Sheet(s).

If you have any questions concerning this submittal, or need additional information, please contact me by telephone at (304) 843-3125 or by e-mail at Dave.Morris@Williams.com.

Sincerely,

David Morris
Environmental Specialist

Enclosures:

Application for NSR Permit Modification
Attachments A thru S
Supplements S1 thru S4
Check for Application Fee

**Application for
45CSR13 New Source Review
Permit Modification (NSR)**

For the:

Appalachia Midstream Services, LLC (AMS)
Battle Run Compressor Station (BRCS)
Plant ID No. 069-00107
Ohio County, West Virginia

Submitted to:



**West Virginia
Department of Environmental Protection
Division of Air Quality**

Submitted by:



Appalachia Midstream Services, LLC
100 Teletech Drive, Suite 2
Moundsville, WV 26041-2352

Prepared by:



EcoLogic Environmental Consultants, LLC
864 Windsor Court
Santa Barbara, CA 93111-1037

February 2018

**Application for
45CSR13 New Source Review
Permit Modification (NSR)**

Appalachia Midstream Services, LLC (AMS)
Battle Run Compressor Station (BRCS)
Plant ID No. 069-00107
Ohio County, West Virginia

Table of Contents

Cover Letter

Title Page / Table of Contents

Application for NSR Permit Modification

- Section I. General Information
- Section II. Additional Attachments and Supporting Documents
- Section III. Certification of Information

Attachments to the NSR Application

- Attachment A Business Certificate
- Attachment B Map(s)
- Attachment C Installation and Start-Up Schedule
- Attachment D Regulatory Discussion
- Attachment E Plot Plan
- Attachment F Process Flow Diagram(s) (PFD)
- Attachment G Process Description
- Attachment H Safety Data Sheets (MSDS)
- Attachment I Emission Units Table
- Attachment J Emission Points Data Summary Sheet(s)
- Attachment K Fugitive Emissions Data Summary Sheet(s)
- Attachment L Emissions Unit Data Sheet(s)
- Attachment M Air Pollution Control Device Sheet(s)
- Attachment N Supporting Emissions Calculations
- Attachment O Monitoring/Recordkeeping/Reporting/Testing Plans
- Attachment P Public Notice
- Attachment Q Business Confidential Claims (NOT APPLICABLE)
- Attachment R Authority Forms (NOT APPLICABLE)
- Attachment S Title V Permit Revision Information (NOT APPLICABLE)

Supplements to the NSR Application

- Supplement S1 Lab Analysis (Inlet Gas)
- Supplement S2 Vendor Data (CAT G3516B / Baldor IGLC420-2N / (BTEX Buster / VRU / CarbCan)
- Supplement S3 Emission Program Data (TANKS-4.0.9d / GRI-GLYCalc)
- Supplement S4 AP-42 / EPA Emission Factors

Application Fee

**Application for
45CSR15 New Source Review
Permit Modification (NSR)**

- **Section I. General**
 - **Section II. Additional Attachments and Supporting Documents**
 - **Section III. Certification of Information**
-



NTAL PROTECTION
DIVISION OF AIR QUALITY
 601 57th Street, SE
 Charleston, WV 25304
 (304) 926-0475
www.dep.wv.gov/daq

**APPLICATION FOR NSR PERMIT
 AND
 TITLE V PERMIT REVISION
 (OPTIONAL)**

PLEASE CHECK ALL THAT APPLY TO **NSR (45CSR13)** (IF KNOWN):

- CONSTRUCTION MODIFICATION RELOCATION
 CLASS I ADMINISTRATIVE UPDATE TEMPORARY
 CLASS II ADMINISTRATIVE UPDATE AFTER-THE-FACT

PLEASE CHECK TYPE OF **45CSR30 (TITLE V)** REVISION (IF ANY):

- ADMINISTRATIVE AMENDMENT MINOR MODIFICATION
 SIGNIFICANT MODIFICATION NOT APPLICABLE

IF ANY BOX ABOVE IS CHECKED, INCLUDE TITLE V REVISION INFORMATION AS **ATTACHMENT S** TO THIS APPLICATION

FOR TITLE V FACILITIES ONLY: Please refer to "Title V Revision Guidance" in order to determine your Title V Revision options (Appendix A, "Title V Permit Revision Flowchart") and ability to operate with the changes requested in this Permit Application.

Section I. General

1. Name of applicant (as registered with the WV Secretary of State's Office): Appalachia Midstream Services, LLC (AMS)	2. Federal Employer ID No. (FEIN): 26-3678972
3. Name of facility (if different from above): Battle Run Compressor Station (BRCS)	4. The applicant is the: <input type="checkbox"/> OWNER <input type="checkbox"/> OPERATOR <input checked="" type="checkbox"/> BOTH
5A. Applicant's mailing address: 100 Teletech Drive, Suite 2 Moundsville, WV 26041	5B. Facility's present physical address: 297 Windmill Truckers Rd Valley Grove, Ohio County, WV 26060
6. West Virginia Business Registration. Is the applicant a resident of the State of West Virginia? <input type="checkbox"/> YES <input checked="" type="checkbox"/> NO - If YES, provide a copy of the Certificate of Incorporation/Organization/Limited Partnership (one page) including any name change amendments or other Business Registration Certificate as Attachment A . - If NO, provide a copy of the Certificate of Authority/Authority of L.L.C./Registration (one page) including any name change amendments or other Business Certificate as Attachment A .	
7. If applicant is a subsidiary corporation, please provide the name of parent corporation: The Williams Companies, Inc.	
8. Does the applicant own, lease, have an option to buy, or otherwise have control of the <i>proposed site</i> ? <input checked="" type="checkbox"/> YES <input type="checkbox"/> NO - If YES, please explain: Applicant owns the Compressor Station - If NO, you are not eligible for a permit for this source.	
9. Type of plant or facility (stationary source) to be constructed, modified, relocated, administratively updated or temporarily permitted (e.g., coal preparation plant, primary crusher, etc.): Natural Gas Compressor Station	10. North American Industry Classification System (NAICS) code for the facility: 213112-Support Activities for Oil and Gas Operations
11A. DAQ Plant ID No. (existing facilities): 069-00107	11B. List all current 45CSR13 and 45CSR30 (Title V) permit numbers associated with this process (existing facilities): R13-2916A - Issued 03/13/13
12A. Directions to the facility: - For Modifications, Administrative Updates or Temporary permits at an existing facility, please provide directions to the <i>present location</i> of the facility from the nearest state road; - For Construction or Relocation permits , please provide directions to the <i>proposed new site location</i> from the nearest state road. Include a MAP as Attachment B . From Wheeling, WV: 1) Head East on I-70 ~9.3 mi; 2) Take Exit 11 ~0.3 mi; 3) Turn Left on Dallas Pike ~0.1 mi; 4) Turn Right on Alexander Rd ~0.2 mi; 5) Turn Left onto Windmill Truckers Rd ~0.3 mi; 6) Destination is straight ahead.	
<i>All of the required forms and additional information can be found under the Permitting Section of DAQ's website, or requested by phone.</i>	

12.B. New site address (if applicable): 297 Windmill Truckers Rd	12C. Nearest city or town: Valley Grove	12D. County: Ohio
12.E. UTM Northing (KM): 4,436.030 km Northing	12F. UTM Easting (KM): 536.535 km Easting	12G. UTM Zone: 17T
13. Briefly describe the proposed change(s) at the facility: This application is prepared and submitted to request modifications to the facility's potential-to-emit (PTE). Although these modifications are significant, the only physical or operational changes proposed are: <ul style="list-style-type: none"> • Remove the requirements to control the Produced Water (PW) Storage Tank (WTK-01 and WTK 02) and the Produced Water (PW) Truck Load-Out (WTLO) emissions. (The combined uncontrolled VOC emissions from WTK and WTLO operations is estimated at 0.14 tpy.) 		
14A. Provide the date of anticipated installation or change: – If this is an After-The-Fact permit application, provide the date upon which the proposed change did happen: NA		14B. Date of anticipated Start-Up if a permit is granted: NA
14C. Provide a Schedule of the planned Installation of/Change to and Start-Up of each of the units proposed in this permit application as Attachment C (if more than one unit is involved).		
15. Provide maximum projected Operating Schedule of activity/activities outlined in this application: Hours Per Day: 24 Days Per Week: 7 Weeks Per Year: 52		
16. Is demolition or physical renovation at an existing facility involved? <input type="checkbox"/> YES <input checked="" type="checkbox"/> NO		
17. Risk Management Plans. If this facility is subject to 112(r) of the 1990 CAAA, or will become subject due to proposed changes (for applicability help see www.epa.gov/ceppo), submit your Risk Management Plan (RMP) to U.S. EPA Region III.		
18. Regulatory Discussion. List all Federal and State air pollution control regulations that you believe are applicable to the proposed process (<i>if known</i>). A list of possible applicable requirements is also included in Attachment S of this application (Title V Permit Revision Information). Discuss applicability and proposed demonstration(s) of compliance (<i>if known</i>). Provide this information as Attachment D .		

Section II. Additional attachments and supporting documents.

19. Include a check payable to WVDEP – Division of Air Quality with the appropriate application fee (per 45CSR22 and 45CSR13).
20. Include a Table of Contents as the first page of your application package.
21. Provide a Plot Plan , e.g. scaled map(s) and/or sketch(es) showing the location of the property on which the stationary source(s) is or is to be located as Attachment E (Refer to Plot Plan Guidance). – Indicate the location of the nearest occupied structure (e.g. church, school, business, residence).
22. Provide a Detailed Process Flow Diagram(s) showing each proposed or modified emissions unit, emission point and control device as Attachment F .
23. Provide a Process Description as Attachment G . – Also describe and quantify to the extent possible all changes made to the facility since the last permit review (if applicable).
24. Provide Material Safety Data Sheets (MSDS) for all materials processed, used or produced as Attachment H . – For chemical processes, provide a MSDS for each compound emitted to the air.
25. Fill out the Emission Units Table and provide it as Attachment I .
26. Fill out the Emission Points Data Summary Sheet (Table 1 and Table 2) and provide it as Attachment J .
27. Fill out the Fugitive Emissions Data Summary Sheet and provide it as Attachment K .
<i>All of the required forms and additional information can be found under the Permitting Section of DAQ's website, or requested by phone.</i>

28. Check all applicable **Emissions Unit Data Sheets** listed below:

<input checked="" type="checkbox"/> Bulk Liquid Transfer Operations (Lf)	<input type="checkbox"/> Haul Road Emissions	<input type="checkbox"/> Quarry
<input checked="" type="checkbox"/> Chemical Processes (*) (Lg)	<input type="checkbox"/> Hot Mix Asphalt Plant	<input type="checkbox"/> Solid Materials Sizing, Handling and Storage Facilities
<input type="checkbox"/> Concrete Batch Plant	<input type="checkbox"/> Incinerator	<input checked="" type="checkbox"/> Storage Tanks (Le)
<input type="checkbox"/> Grey Iron and Steel Foundry	<input type="checkbox"/> Indirect Heat Exchanger	

General Emission Unit, specify:

- **Natural Gas Compressor/Generator Engine Data Sheet (La)**
- **Natural Gas Glycol Dehydration Unit Data Sheet (Lb, Lc)**
- **Fired Boiler/Line Heater Data Sheet (Ld)**

(*) **Leak Source Data Sheet Only**

Fill out and provide the **Emissions Unit Data Sheet(s)** as **Attachment L**.

29. Check all applicable **Air Pollution Control Device Sheets** listed below:

<input type="checkbox"/> Absorption Systems	<input type="checkbox"/> Baghouse	<input type="checkbox"/> Flare
<input checked="" type="checkbox"/> Adsorption Systems (CarbCan)	<input checked="" type="checkbox"/> Condenser (BTEX Buster)	<input type="checkbox"/> Mechanical Collector
<input type="checkbox"/> Afterburner	<input type="checkbox"/> Electrostatic Precipitator	<input type="checkbox"/> Wet Collecting System

Other Collectors, specify:

- **Oxidation Catalyst (OxCat)**
- **Non-Selective Catalytic Reduction (NSCR)**
- **Vapor Recover Unit (VRU)**

Fill out and provide the **Air Pollution Control Device Sheet(s)** as **Attachment M**.

30. Provide all **Supporting Emissions Calculations** as **Attachment N**, or attach the calculations directly to the forms listed in Items 28 through 31.

31. **Monitoring, Recordkeeping, Reporting and Testing Plans.** Attach proposed monitoring, recordkeeping, reporting and testing plans in order to demonstrate compliance with the proposed emissions limits and operating parameters in this permit application. Provide this information as **Attachment O**.

➤ Please be aware that all permits must be practically enforceable whether or not the applicant chooses to propose such measures. Additionally, the DAQ may not be able to accept all measures proposed by the applicant. If none of these plans are proposed by the applicant, DAQ will develop such plans and include them in the permit.

32. **Public Notice.** At the time that the application is submitted, place a Class I Legal Advertisement in a newspaper of general circulation in the area where the source is or will be located (See 45CSR§13-8.3 through 45CSR§13-8.5 and *Example Legal Advertisement* for details). Please submit the **Affidavit of Publication** as **Attachment P** immediately upon receipt.

33. **Business Confidentiality Claims.** Does this application include confidential information (per 45CSR31)?

YES NO

➤ If YES, identify each segment of information on each page that is submitted as confidential and provide justification for each segment claimed confidential, including the criteria under 45CSR§31-4.1, and in accordance with the DAQ's "**Precautionary Notice – Claims of Confidentiality**" guidance found in the *General Instructions* as **Attachment Q**.

Section III. Certification of Information

34. **Authority/Delegation of Authority.** Only required when someone other than the responsible official signs the application. Check applicable Authority Form below: **na**

<input type="checkbox"/> Authority of Corporation or Other Business Entity	<input type="checkbox"/> Authority of Partnership
<input type="checkbox"/> Authority of Governmental Agency	<input type="checkbox"/> Authority of Limited Partnership

Submit completed and signed **Authority Form** as **Attachment R**.

All of the required forms and additional information can be found under the Permitting Section of DAQ's website, or requested by phone.

35A. Certification of Information. To certify this permit application, a Responsible Official (45CSR§13-2.22 and 45CSR§30-2.28) or Authorized Representative shall check the appropriate box and sign below.

Certification of Truth, Accuracy, and Completeness

I, the undersigned **Responsible Official** / **Authorized Representative**, hereby certify that all information contained in this application and any supporting documents appended hereto, is true, accurate, and complete based on information and belief after reasonable inquiry I further agree to assume responsibility for the construction, modification and/or relocation and operation of the stationary source described herein in accordance with this application and any amendments thereto, as well as the Department of Environmental Protection, Division of Air Quality permit issued in accordance with this application, along with all applicable rules and regulations of the West Virginia Division of Air Quality and W.Va. Code § 22-5-1 et seq. (State Air Pollution Control Act). If the business or agency changes its Responsible Official or Authorized Representative, the Director of the Division of Air Quality will be notified in writing within 30 days of the official change.

Compliance Certification

Except for requirements identified in the Title V Application for which compliance is not achieved, I, the undersigned hereby certify that, based on information and belief formed after reasonable inquiry, all air contaminant sources identified in this application are in compliance with all applicable requirements.

SIGNATURE: _____
(Please use blue ink)

DATE: _____
(Please use blue ink)

35B. Printed name of signee: Paul V. Hunter	35C. Title: Vice President
35D. E-mail: PaulV.Hunter@Williams.com	36E. Phone: (412) 787-5561
	36F. FAX: (412) 787-6002
36A. Printed name of contact person: David Morris	36B. Title: Environmental Specialist
36C. E-mail: Dave.Morris@Wiliams.com	36D. Phone: (304) 834-3125
	36E. FAX: ---

PLEASE CHECK ALL APPLICABLE ATTACHMENTS INCLUDED WITH THIS PERMIT APPLICATION:

- | | |
|--|--|
| <input checked="" type="checkbox"/> Attachment A: Business Certificate | <input checked="" type="checkbox"/> Attachment K: Fugitive Emissions Data Summary Sheet |
| <input checked="" type="checkbox"/> Attachment B: Map(s) | <input checked="" type="checkbox"/> Attachment L: Emissions Unit Data Sheet(s) |
| <input checked="" type="checkbox"/> Attachment C: Installation and Start Up Schedule | <input checked="" type="checkbox"/> Attachment M: Air Pollution Control Device Sheet(s) |
| <input checked="" type="checkbox"/> Attachment D: Regulatory Discussion | <input checked="" type="checkbox"/> Attachment N: Supporting Emissions Calculations |
| <input checked="" type="checkbox"/> Attachment E: Plot Plan | <input checked="" type="checkbox"/> Attachment O: Monitoring/Recordkeeping/Reporting/Testing Plans |
| <input checked="" type="checkbox"/> Attachment F: Detailed Process Flow Diagram(s) | <input checked="" type="checkbox"/> Attachment P: Public Notice |
| <input checked="" type="checkbox"/> Attachment G: Process Description | <input type="checkbox"/> Attachment Q: Business Confidential Claims) (NA) |
| <input checked="" type="checkbox"/> Attachment H: Material Safety Data Sheets (MSDS) | <input type="checkbox"/> Attachment R: Authority Forms) (NA) |
| <input checked="" type="checkbox"/> Attachment I: Emission Units Table | <input type="checkbox"/> Attachment S: Title V Permit Revision Information (NA) |
| <input checked="" type="checkbox"/> Attachment J: Emission Points Data Summary Sheet | <input checked="" type="checkbox"/> Application Fee |

Please mail an original and three (3) copies of the complete permit application with the signature(s) to the DAQ, Permitting Section, at the address listed on the first page of this application. Please DO NOT fax permit applications.

FOR AGENCY USE ONLY – IF THIS IS A TITLE V SOURCE:

- Forward 1 copy of the application to the Title V Permitting Group and
- For Title V Administrative Amendments:
 - NSR permit writer should notify Title V permit writer of draft permit
- For Title V Minor Modifications:
 - Title V permit writer should send appropriate notification to EPA and affected states within 5 days of receipt,
 - NSR permit writer should notify Title V permit writer of draft permit.
- For Title V Significant Modifications processed in parallel with NSR Permit revision:
 - NSR permit writer should notify a Title V permit writer of draft permit,
 - Public notice should reference both 45CSR13 and Title V permits,
 - EPA has 45-day review period of a draft permit.

All the required forms and additional information can be found under the Permitting Section of DAQ's website, or requested by phone.

Attachment A

Business Certificate

“6. **West Virginia Business Registration.** Provide a copy of the Certificate of Authority/Authority of L.L.C./Registration (one page) including any name change amendments or other Business Certificate as Attachment A.”

- **Business Registration Certificate**

To: Appalachia Midstream Services, LLC

Date: 06/30/10

**WEST VIRGINIA
STATE TAX DEPARTMENT
BUSINESS REGISTRATION
CERTIFICATE**

ISSUED TO:
**APPALACHIA MIDSTREAM SERVICES, L.L.C.
900 PENNSYLVANIA AVE
CHARLESTON, WV 25302-3548**

BUSINESS REGISTRATION ACCOUNT NUMBER: 2222-3681

This certificate is issued on: **06/30/2010**

*This certificate is issued by
the West Virginia State Tax Commissioner
in accordance with W.Va. Code § 11-12.*

*The person or organization identified on this certificate is registered
to conduct business in the State of West Virginia at the location above.*

This certificate is not transferrable and must be displayed at the location for which issued.

This certificate shall be permanent until cessation of the business for which the certificate of registration was granted or until it is suspended, revoked or cancelled by the Tax Commissioner.

Change in name or change of location shall be considered a cessation of the business and a new certificate shall be required.

TRAVELING/STREET VENDORS: Must carry a copy of this certificate in every vehicle operated by them.
CONTRACTORS, DRILLING OPERATORS, TIMBER/LOGGING OPERATIONS: Must have a copy of this certificate displayed at every job site within West Virginia.

Attachment B

Map(s)

“12A. For Modifications, Administrative Updates or Temporary permits at an existing facility, please **provide directions to the present location** of the facility from the nearest state road. Include a MAP as Attachment B.”

- **Location:**

Battle Run Compressor Station (BRCS)
297 Windmill Truckers Rd
Valley Grove, Ohio County, WV 26060

- **Latitude and Longitude:**

Lat: 40°04'25.5"N x Lon: -80°34'17.5"W
Lat: 40.073743°N x Lon: -80.571539°W

- **UTM:**

536.535 km E x 4,436.030 km N x 17T

- **Elevation:**

~1,210'

- **USGS:**

2016 USGS US Topo 7.5 - minute map for VALLEY GROVE, WV-PA

- **Directions:**

From Wheeling, WV:

- 1) Head East on I-70 ~9.3 mi
 - 2) Take Exit 11 ~0.3 mi
 - 3) Turn Left on Dallas Pike ~0.1 mi
 - 4) Turn Right on Alexander Rd ~0.2 mi
 - 5) Turn Left onto Windmill Truckers Rd ~0.3 mi
 - 6) Destination is straight ahead.
-

Appalachia Midstream Services, LLC (AMS)
Battle Run Compressor Station (BRCS)
 Application for 45CSR13 New Source Review Permit Modification (NSR)

Attachment B - Area Map

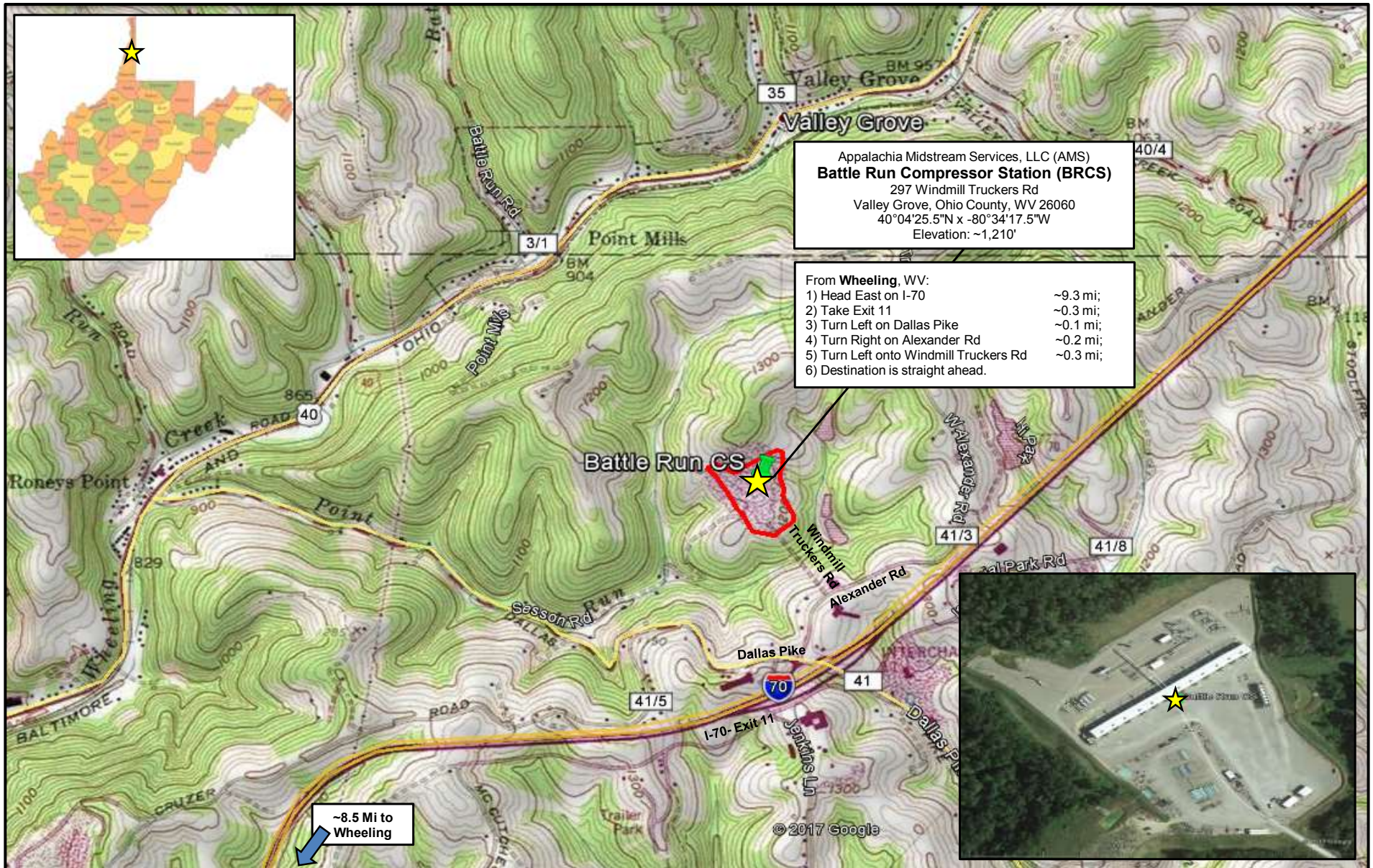

Attachment C

Installation and Start-Up Schedule

“14C. Provide a **Schedule** of the planned **Installation of/Change** to and **Start-Up** of each of the units proposed in this permit application as Attachment C.”

This application is prepared and submitted to request modifications to the facility’s potential-to-emit (PTE). Although these modifications are significant, the only physical or operational changes proposed are to remove the requirements to control the Produced Water Storage Tank (WTK-01 and WTK-02) and Produced Water Truck Load-Out (WTLO) emissions. (Combined uncontrolled VOC emissions from WTK and WTLO sources is estimated at 0.14 tpy.)

Attachment D

Regulatory Discussion

“18. **Regulatory Discussion.** List all Federal and State air pollution control regulations that you believe are applicable to the proposed process (if known). Discuss applicability and proposed demonstration(s) of compliance (if known). Provide this information as Attachment D.”

- **Regulatory Discussion**
 - A. Applicability of New Source Review (NSR) Regulations
 - B. Applicability of Federal Regulations
 - C. Applicability of Source Aggregation
 - D. Applicability of State Regulations
-

Appalachia Midstream Services, LLC (AMS)
Battle Run Compressor Station (BRCS)
Application for 45CSR13 New Source Review Permit Modification (NSR)

Attachment D
Regulatory Discussion

A. Applicability of New Source Review (NSR) Regulations

The following New Source Review (NSR) regulations are potentially applicable to natural gas compressor stations. Applicability to the subject facility has been determined as follows:

1. Prevention of Significant Deterioration (PSD) [Not Applicable]

This rule does not apply to the subject facility because the total PTE for the entire facility qualifies as a “PSD Minor Source” for each regulated pollutant; as follows:

- NOx: PSD Natural Minor Source with Pre-Controlled PTE < 250 tpy
- CO: PSD Synthetic Minor Source with Controlled PTE < 250 tpy
- VOC: PSD Synthetic Minor Source with Controlled PTE < 250 tpy
- SO₂: PSD Natural Minor Source with Pre-Controlled PTE < 250 tpy
- PM_{10/2.5}: PSD Natural Minor Source with Pre-Controlled PTE < 250 tpy

2. Non-Attainment New Source Review (NNSR) [Not Applicable]

This rule does not apply to the subject facility. The operations are in Ohio County, WV, which is currently classified as Attainment, Unclassified, or Maintenance for all national ambient air quality standards (NAAQS).

3. Major Source of Hazardous Air Pollutants (HAPs) [Not Applicable]

This rule does not apply to the subject facility because the entire facility qualifies as a “HAP Area Source” as follows:

- Each HAP: HAP Area Source with Controlled Individual HAP PTE < 10 tpy
- Total HAPs: HAP Area Source with Controlled Total of All HAPs PTE < 25 tpy

4. Title V Operating Permit (TVOP) [Applicable]

This rule does apply because the potential to emit VOC is above than the Title V Major Source threshold of 100 tpy.

B. Applicability of Federal Regulations

The following federal regulations are potentially applicable to natural gas compressor stations. Applicability to the subject facility has been determined as follows:

1. **NSPS A, General Provisions**

40CFR§60.1-§60.19

[Applicable]

This rule does apply to all sources subject to an NSPS (unless a specific provision is excluded within the source NSPS). Requirements include notification (§60.7); monitoring (§60.7); recordkeeping (§60.11); and reporting (§60.18)

2. **NSPS A, Control Devices - Flares**

40CFR§60.18(b)

[Not Applicable]

This rule does not apply because there is no flare at the subject facility.

3. **NSPS D (also Da, Db, and Dc), Steam Generating Units**

40CFR§60.40-§60.48

[Not Applicable]

These rules do not apply because there is no steam generating unit (including line heaters) at the subject facility with a maximum design heat input capacity ≥ 10 MMBtu/hr and ≤ 100 MMBtu/hr (§60.40c(a)).

4. **NSPS K (also Ka and Kb), Volatile Organic Liquid Storage Vessels**

40CFR§60.40-§60.48

[Not Applicable]

This rule does not apply because there is no tank with capacity ≥ 75 m³ (471.7 bbl or 19,813 gal) that is used to store volatile organic liquids (VOL) at the subject facility (§60.110(a)).

5. **NSPS GG, Stationary Gas Turbines**

40CFR§60.330-§60.335

[Not Applicable]

This rule does not apply because there is no stationary gas turbine at the subject facility (§60.330).

6. **NSPS KKK, Leaks from Natural Gas Processing Plants**

40CFR§60.630-§60.636

[Not Applicable]

This rule does not apply because the subject facility is not a natural gas processing plant (§60.630(a)).

7. **NSPS LLL, Onshore Natural Gas Processing: SO₂ Emissions**

40CFR§60.640-§60.648

[Not Applicable]

This rule does not apply because there is no gas sweetening operation at the subject facility (§60.640(a)).

8. NSPS IIII, Compression Ignition Reciprocating Internal Combustion Engines
40CFR§60.4200-§60.4219 [Not Applicable]

This rule does not apply because there is no stationary compression ignition engine at the subject facility (§60.4200(a)).

9. NSPS JJJJ, Stationary Spark Ignition (SI) Internal Combustion Engines (ICE)
40CFR§60.4230-§60.4248 [Applicable]

This rule does apply to the 1,380 bhp Caterpillar G3516B compressor engines (CE-01 thru CE-12) and the 605 bhp Baldor IGLC420-2N (non-emergency) generator engine (GEN) because each engine has a power rating greater than 500 HP and each engine was manufactured on or after 07/01/07 (§60.4230(a)(4)(i)).

Requirements include NO_x, CO and VOC emission limits (§60.4233(e-f)); operating limits (§60.4243); performance testing (§60.4244); and notification and recordkeeping (§60.4245).

10. NSPS KKKK, Stationary Combustion Turbines
40CFR§60.4300-§60.4420 [Not Applicable]

This rule does not apply because there is no stationary combustion turbine at the subject facility (§60.4300).

11. NSPS OOOO, Crude Oil and Natural Gas Production
40CFR§60.5360-§60.5430 [Applicable]

This rule does apply to each reciprocating compressor driven by a CAT G3516B engine (CE-01 thru CE-12) because the subject facility is identified within the natural gas production segment and the compressors commenced construction after 08/23/11 (§60.5360 and §60.5365(c)).

Requirements include replacing rod packing systems on a specified schedule (§60.5385(a)) and notification, monitoring, recordkeeping and reporting (§60.5410(c), §60.5415(c), §60.5420(b)(1) and §60.5420(b)(4)).

This rule does not apply to the stabilized condensate (SC) storage tanks (TK-01 thru TK-08) nor to the produced water (PW) storage tanks (WTK-01 and WTK-02) because each tank does not have the potential to emit VOC ≥ 6 TPY. Note, however, there is a requirement to document that the VOC PTE is < 6 tpy per tank (§60.5420).

This rule does not apply to the pneumatic controllers because they are compressed air driven, else they have a bleed rate ≤ 6 scfh, are located between the wellhead and point of custody transfer, and are not located at a natural gas processing plant (§60.5365(d)(1)).

12. NSPS OOOOa, Crude Oil and Natural Gas Production
40CFR§60.5360a-§60.5430a [Not Applicable]

This rule does not apply because the subject facility was constructed prior to September 18, 2015 (§60.5360a).

13. NESHAP Part 61 - Designated Source Standards

40CFR§61.01-§61.359

[Not Applicable]

This rule does not apply because the subject facility is not a NESHAP Designated Facility (or Source).

Specifically, NESHAP J - Equipment Leaks (Fugitive Emission Sources) of Benzene and NESHAP V - Equipment Leaks (Fugitive Emission Sources) do not apply because all the fluids (liquid or gas) at the subject facility are < 10 wt% volatile hazardous air pollutant (VHAP) (§61.111 and §61.241).

14. NESHAP A (Part 63 (aka, MACT)) - General Provisions

40CFR§63.1-§63.16

[Applicable]

This rule does apply because the dehydrators (DHY-01 thru DHY-03) are subject NESHAP HH–Oil and Natural Gas Production Facilities, and the compressor engines (CE-01 thru CE-12) and the generator engine (GEN) are subject to NESHAP ZZZZ–Reciprocating Internal Combustion Engines (RICE).

15. NESHAP HH, Oil and Natural Gas Production Facilities

40CFR§63.760-§63.779

[Applicable/Exempt]

This rule does apply; however, because the subject facility is an area source of HAP emissions, and the actual average emissions of benzene from each glycol dehydration unit process vent to the atmosphere is < 0.90 megagram per year (1.0 tpy), the dehydration units (DHY-01 thru DHY-03) are exempt. The only requirement is to maintain records of the actual average benzene emissions per year (§63.774(d)(1)(i)).

This rule does not apply to storage vessels (tanks), compressors, or ancillary equipment because the subject facility is an area source of HAP emissions (§63.760(b)(2)).

16. NESHAP HHH, Natural Gas Transmission and Storage Facilities

40CFR§63.1270-§63.1289

[Not Applicable]

This rule does not apply because the subject facility is not a natural gas transmission or storage facility transporting or storing natural gas prior to local distribution (§63.1270(a)).

17. NESHAP YYYY, Stationary Combustion Turbines

40CFR§63.6080-§63.6175

[Not Applicable]

This rule does not apply because there is no stationary gas turbine at the subject facility (§63.6080).

18. NESHAP ZZZZ, Stationary Reciprocating Internal Combustion Engines (RICE)

40CFR§63.6580-§63.6675

[Applicable]

This rule does apply to the 1,380 bhp CAT G3516B Compressor Engines (CE-01 thru CE-12). However, because each engine is “new”; i.e., commenced construction or reconstruction on or after 06/12/06 (§63.6590(a)(2)(iii)); the only requirement is compliance with §60.4230-§60.4248 (NSPS JJJJ) for Spark Ignition Internal Combustion Engines.

19. NESHAP DDDDD, Industrial, Commercial, and Institutional Boilers and Process Heaters – Major Sources

40CFR§63.7480 – §63.7575

[Not Applicable]

This rule does not apply because the subject facility is an area source of HAP emissions (§63.7485).

20. NESHAP JJJJJJ, Industrial, Commercial, and Institutional Boilers and Process Heaters – Area Sources

40CFR§63.11193 – §63.11237

[Not Applicable]

This rule does not apply because all boilers (BLR-01 thru BLR-03) and heaters (HTR-01 and HTR-02) at the subject facility are gas-fired (§63.11195(e)).

21. Compliance Assurance Monitoring (CAM)

40CFR§64.1-§64.10

[Applicable/Deferred]

This rule does apply to the dehydrators (DHY-01 thru DHY-03) because they are:

- a) Pollutant-specific emission units (PSEUs) at a major source that is required to obtain a Title V operating permit;
- b) Subject to an emissions limitation or standard;
- c) Use a control device to achieve compliance with any such emission limitation or standard; and
- d) The potential pre-control emissions of the applicable regulated air pollutant are \geq 100% of the amount required to be classified as a major source (§64.2).

Note: Only large PSEUs (i.e., PSEUs with potential post-control device emissions of an applicable regulated air pollutant that are \geq Major Source Threshold Levels) need to submit a CAM plan with the initial TVOP application. At the subject facility, the post-control emissions are < Major Source Threshold Levels (§64.5(b)).

22. Chemical Accident Prevention Provisions (Risk Management Plan (RMP))

40CFR§68.1-§68.220

[Not Applicable]

This rule does not apply because the subject facility does not store more than a threshold quantity of a regulated substance in a process. Specifically, “Prior to entry into a natural gas processing plant or a petroleum refining process unit, regulated substances in naturally occurring hydrocarbon mixtures need not be considered when determining whether more than a threshold quantity is present at a stationary source” (§68.115(b)(2)(iii)).

23. Mandatory Greenhouse Gases (GHG) Reporting

40CFR§98.1-§98.9

[Applicable]

This rule applies because:

- a) The facility is not a listed source category;
- b) The aggregate max heat input capacity of stationary fuel combustion units at the facility is ≥ 30 MMBtu/hr;
- c) The CO₂e emissions from all stationary sources combined within the hydrocarbon basin as defined in 40 CFR Part 98 is $\geq 25,000$ metric ton/yr (§98.2(a)(3)).

Requirements include monitoring, recordkeeping, and annual reporting of GHG from stationary fuel combustion sources only (§98.2(a)(3)).

C. Applicability of Source Aggregation

The operations of the subject facility have not been aggregated with any other gas production, midstream service facilities, or transportation operations because there are no oil and gas facilities or operations “contiguous and adjacent” to the subject facility. Furthermore, there are no related facilities or operations that meet the common-sense notion of a plant and/or are under common control.

D. Applicability of State Regulations

The following state regulations are potentially applicable to natural gas compressor stations. Applicability to the subject facility has been determined as follows:

1. **Particulate Air Pollution from Combustion of Fuel in Indirect Heat Exchangers**

§45CSR2

[Not Applicable]

This rule does not apply because there is no indirect heat exchanger at the subject facility with input capacity ≥ 10 MMBtu/hr.

2. **Prevent and Control the Discharge of Air Pollutants into the Open Air Which Causes or Contributes to an Objectionable Odor or Odors**

§45CSR4

[Applicable]

This rule does apply and states that an objectionable odor is an odor that is deemed objectionable when in the opinion of a duly authorized representative of the Air Pollution Control Commission (Division of Air Quality), based upon their investigations and complaints, such odor is objectionable.

3. **Control of Air Pollution from Combustion of Refuse**

45CSR6

[Not Applicable]

This rule does not apply because there is no refuse combustion performed at the subject facility.

4. Prevent and Control Air Pollution from the Emission of Sulfur Oxides

45CSR10

[Applicable]

This rule does apply and limits the discharge of SO₂ to 3.1 lb/hr per million Btu of total design heat input (§45-10-3.1.d).

5. Permits for Construction, Modification, Relocation and Operation of Stationary Sources of Air Pollutants, Notification Requirements, Administrative Updates, Temporary Permits, General Permits, and Procedures for Evaluation

45CSR13

[Applicable]

This rule does apply because the increase in VOC emissions is > 6 lb/hr and 10 tpy.

Regulation 45CSR13 is applicable to new sources or modifications that result in an emission increase of:

- 6 lb/hr and 10 tons/yr of any regulated pollutant, or
- 144 lb/day of any regulated pollutant, or
- 2 lb/hr or 5 tons/yr of HAPs.

Appalachia Midstream Services, LLC (AMS) is applying for a 45CSR13 New Source Review Permit Modification and has published the required Class I legal advertisement notifying the public of this application and paid the appropriate application fee.

6. Permits for Construction and Major Modification of Major Stationary Sources of Air Pollutants for Prevention of Significant Deterioration

45CSR14

[Not Applicable]

The rule does not apply because the subject facility is neither a new PSD major source of pollutants nor is the proposed facility a modification to an existing PSD major source.

7. Standards of Performance for New Stationary Sources Pursuant to 40 CFR Part 60

45CSR16

[Applicable]

The rule does apply to this source by reference to §40CFR60 Subparts JJJJ and OOOO. The subject facility is subject to the notification, testing, monitoring, recordkeeping and reporting requirements of these Subparts.

8. Permits for Construction and Major Modification of Major Stationary Sources of Air Pollution Which Cause or Contribute to Nonattainment

45CSR19

[Not Applicable]

This rule does not apply. The subject facility location is designated as "Attainment/Unclassified" for all criteria pollutants.

9. Regulation of Volatile Organic Compounds (VOC)

45CSR21

[Not Applicable]

This rule does not apply because the subject facility is not located in Putnam County, Kanawha County, Cabell County, Wayne County, or Wood County.

10. Air Quality Management Fees Program

45CSR22

[Applicable]

This rule does apply. It establishes a program to collect fees for certificates to operate and for permits to construct, modify or relocate sources of air pollution.

11. Prevent and Control Emissions of Toxic Air Pollutants (Best Available Control Technology (BAT))

45CSR27

[Not Applicable]

This rule does not apply because equipment used in the production and distribution of petroleum products is exempt, provided that the product contains no more than 5% benzene by weight (§45-27-2.4).

12. Air Pollution Emissions Banking and Trading

45CSR28

[Not Applicable]

This rule does not apply. Appalachia Midstream Services, LLC (AMS) does not choose to participate in the voluntarily statewide air pollutant emissions trading program.

13. Emission Statements for VOC and NOX

45CSR29

[Not Applicable]

This rule does not apply because subject facility is not located in Putnam, Kanawha, Cabell, Wayne, Wood, or Greenbrier Counties (§45-29-1).

14. Requirements for Operating Permits

45CSR30

[Applicable]

This rule does apply because the potential to emit VOC is above than the Title V Major Source threshold of 100 tpy (§45-30-4.1.a.2).

15. Emission Standards for Hazardous Air Pollutants (HAP)

45CSR34

[Applicable]

This rule does apply because it incorporates by reference the federal air toxic regulations under the NESHAP program (40CFR61 and 40CFR63).

Attachment E

Plot Plan

“21. Provide a **Plot Plan**, e.g. scaled map(s) and/or sketch(es) showing the location of the property on which the stationary source(s) is or is to be located as Attachment E.”

- **Plot Plan – Battle Run Compressor Station (BRCS)**
-

Appalachia Midstream Services, LLC (AMS)
Battle Run Compressor Station (BRCS)
 Application for 45CSR13 New Source Review Permit Modification (NSR)

Attachment E - Plot Plan

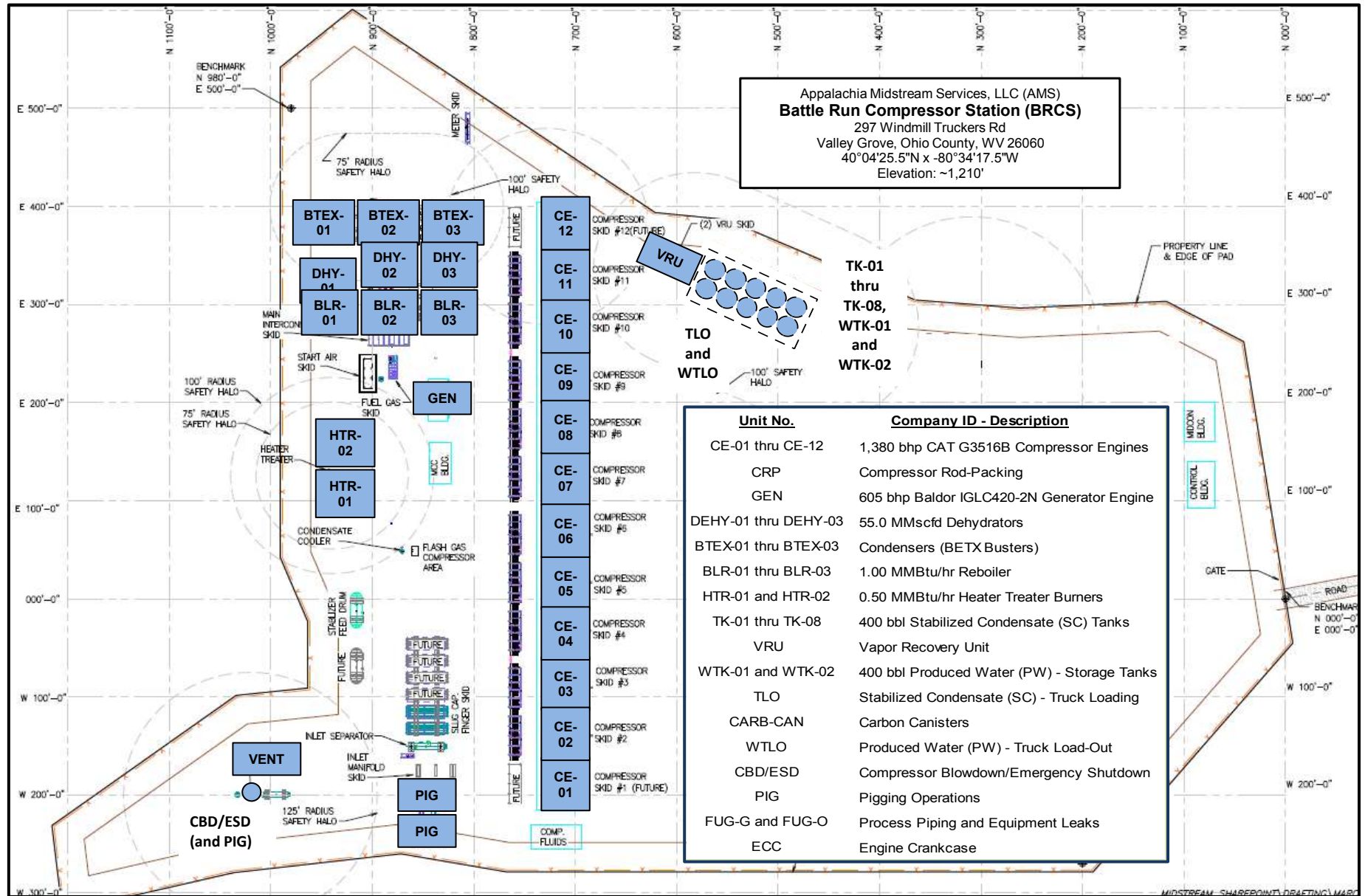

Attachment F
Process Flow Diagram(s) (PFD)

“22. Provide a **Detailed Process Flow Diagram(s)** showing each proposed or modified emissions unit, emission point and control device as Attachment F.”

- **Process Flow Diagram (PFD) – Battle Run Compressor Station (BRCS)**
-

Battle Run Compressor Station (BRCS)

Application for 45CSR13 New Source Review Permit Modification (NSR)

Attachment F - Process Flow Diagram (PFD)

Fugitive Emissions from Flanges, Valves, Pump and Compressor Seals, Etc (FUG-G and FUG-O)

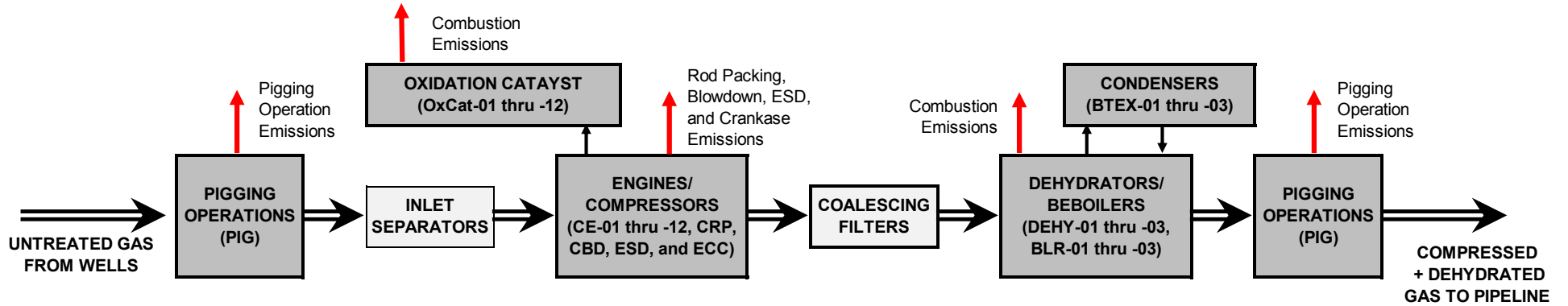

Unit No.	Company ID - Description
CE-01 thru CE-12	1,380 bhp CAT G3516B Compressor Engines
CRP	Compressor Rod-Packing
GEN	605 bhp Baldor IGLC420-2N Generator Engine
DEHY-01 thru DEHY-03	55.0 MMscfd Dehydrators
BTEX-01 thru BTEX-03	Condensers (BETX Busters)
BLR-01 thru BLR-03	1.00 MMBtu/hr Reboiler
HTR-01 and HTR-02	0.50 MMBtu/hr Heater Treater Burners
TK-01 thru TK-08	400 bbl Stabilized Condensate (SC) Tanks
VRU	Vapor Recovery Unit
WTK-01 and WTK-02	400 bbl Produced Water (PW) - Storage Tanks
TLO	Stabilized Condensate (SC) - Truck Loading
CARB-CAN	Carbon Canisters
WTLO	Produced Water (PW) - Truck Load-Out
CBD/ESD	Compressor Blowdown/Emergency Shutdown
PIG	Pigging Operations
FUG-G and FUG-O	Process Piping and Equipment Leaks
ECC	Engine Crankcase

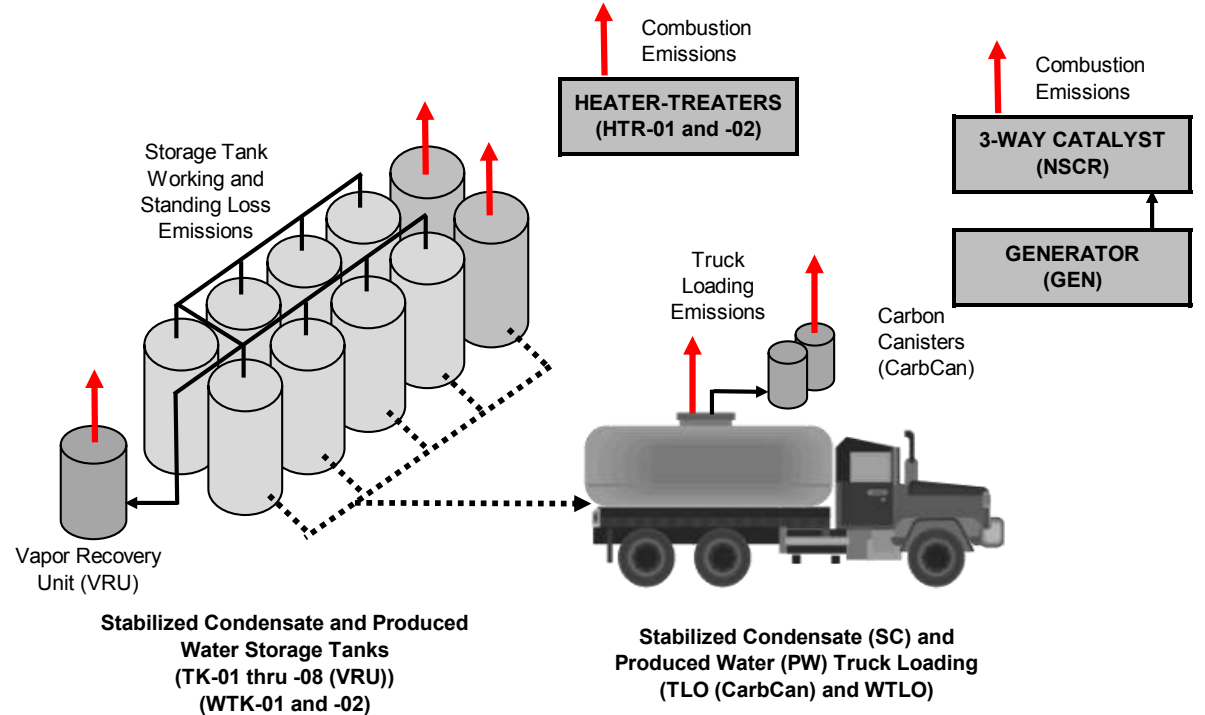

Attachment G

Process Description

“23. Provide a **Process Description** as Attachment G. Also describe and quantify to the extent possible all changes made to the facility since the last permit review (if applicable).”

- **Process Description – Battle Run Compressor Station (BRCS)**
-

Appalachia Midstream Services, LLC (AMS)
Battle Run Compressor Station (BRCS)
Application for 45CSR13 New Source Review Permit Modification (NSR)

Attachment G
Process Description

The natural gas inlet stream from surrounding area wells enters the facility at low pressure through a two-phase low-pressure inlet separator that gravity separates the inlet stream into two streams: gas and hydrocarbon/water liquids. Low-pressure inlet gas is compressed via three-stage reciprocating compressors with inter-stage cooling. Discharge from the compressors passes through filter/coalescer-separators to remove any condensed or entrained liquids present.

After the inlet gas passes through compressors, it goes through the dehydration process before exiting the facility via a sales pipeline. A portion of the discharge gas is removed prior to outlet metering for use as fuel gas.

Triethylene glycol (TEG) dehydration units are used to remove water from the gas. The units are comprised of both a glycol contactor skid and a glycol regeneration skid. In the dehydration process, gas passes through a contactor vessel where water is absorbed by the glycol. The “rich” glycol containing water goes to the glycol reboiler where heat is used to remove the water and regenerate the glycol. The heat is supplied by a natural gas-fired reboiler that exhausts to the atmosphere.

Flash tank off-gases from the glycol regeneration skid are routed to the reboiler to be burned as fuel (100% recycle). Overhead still column emissions from the glycol regeneration skid are controlled by an air-cooled condenser. The non-condensables from the still column overheads are also routed to the reboiler and burned with 95% destruction efficiency.

The TEG reboilers are equipped with a burner management system to ensure a constant flame for combustion of the vapors. Any excess vapors not burned as fuel is recycled or recompressed for 100% control efficiency.

After dehydration, fuel gas is pulled from the discharge side of the process. A fuel gas skid (not an emission source) reduces the pressure of a portion of the discharge gas to a pressure suitable for use by fuel-burning equipment.

Inlet liquids will flow from the two-phase low-pressure inlet separator to a heater-treater feed drum, a three-phase low pressure separator. Heavy liquids (water) will be separated and sent to atmospheric produced water storage tanks. Produced water will be transported off site via truck. Liquid hydrocarbons (condensate) will flow from the feed drum to the heater treater.

Any vapors evolved from the liquid to the feed drum will be routed to the electric-driven flash gas compressor and recycled to the two-phase low-pressure inlet separator. After stabilization, condensate will be sent to atmospheric condensate storage tanks. The stabilized condensate storage tanks include vapor recovery unit (VRU) which operates at a minimum of 95% control efficiency.

Produced water and stabilized condensate will be transported off site via truck. Vapors evolved from truck loading stabilized condensate are routed to carbon canisters for VOC recovery with 70% collection effectiveness and 95% control efficiency (66.5% combined).

The facility has several liquid recycle streams to reduce emissions. All high-pressure liquids are cascaded to lower pressure separators to capture gases evolved as a result of pressure reduction. All liquids formed by gas cooling in the inter-stage coolers of the three-stage reciprocating compressors are cascaded to lower pressure scrubbers on the compressor skid.

The facility also has several gas recycle streams. All condensate storage tank emissions are controlled 95% by vapor recovery compression. The vapor recovery compressors discharge in the flash gas compressor. The flash gas compressor compresses these gases and discharge into the two-phase low-pressure inlet separator. Overhead gases from the heater-treater feed drum and heater treater are routed to the flash gas compressor and recycled to the two-phase low-pressure inlet separator.

The generator provides electric power to the vapor recovery and flash gas compressors, electric glycol pumps, and other electrical equipment. Fugitive emissions from component leaks will also occur.

Please note that the compressor station will have two primary suction pressure operating points, 125 psig and 50 psig. The expected discharge pressure range is 900 – 1,200 psig. The facility initially operates at 125 psig suction pressure and will continue to do so until such time that field production volumes decline. At that time, the suction pressure will be lowered to 50 psig, resulting in a diminished facility capacity.

Attachment H

Safety Data Sheets (SDS) (And Representative Gas Analysis)

“24. Provide **Safety Data Sheets (SDS)** for all materials processed, used or produced as Attachment H. For chemical processes, provide a SDS for each compound emitted to the air.”

- **SAFETY DATA SHEETS (SDS):**

Williams Safety Data Sheets (SDS) provide detailed information needed to use the products in a safe and environmentally acceptable manner and meet local, state and federal requirements.

Copies of SDS can be accessed at: <http://co.williams.com/safety/safety-data-sheets/>

- Butane, Normal
 - Carbon Dioxide
 - Crude Butadiene
 - Debutanized Aromatic Concentrate
 - Demethanized-Mix Y Grade
 - Ethane/Propane Mix
 - Ethane Purity
 - Ethylene
 - Isobutane
 - Liquid Natural Gas LNG
 - Mixed Butane
 - Natural Gas Condensate Sour
 - Natural Gas Condensate Sweet
 - Natural Gas Liquids NGL
 - Natural Gas
 - Natural Gasoline
 - Propane
 - Propylene Polymer Grade
 - Reclaimed Methanol
 - Rich Water
 - Wellhead Natural Gas
-

Attachment I

Emission Units Table

“25. Fill out the **Emission Units Table** and provide it as ATTACHMENT I.”

- **Emission Unit Table – Battle Run Compressor Station (BRCS)**
-

Attachment I
EMISSION UNITS TABLE

(Include all emission units and air pollution control devices
that will be part of this permit application review, regardless of permitting status.)

Emission Unit ID ¹	Emission Point ID ²	Source ID	Emission Unit Description	Installed/Modified	Design Capacity	Type ³ and Date of Change	Control Device ⁴
EUCE-1	EPCE-1	CE-01	Compressor Engine 01 - CAT G3516B (OxCat)	'12/'18	1,380 bhp	Modified	OxCat-01
EUCE-2	EPCE-2	CE-02	Compressor Engine 02 - CAT G3516B (OxCat)	'12/'18	1,380 bhp	Modified	OxCat-02
EUCE-3	EPCE-3	CE-03	Compressor Engine 03 - CAT G3516B (OxCat)	'12/'18	1,380 bhp	Modified	OxCat-03
EUCE-4	EPCE-4	CE-04	Compressor Engine 04 - CAT G3516B (OxCat)	'12/'18	1,380 bhp	Modified	OxCat-04
EUCE-5	EPCE-5	CE-05	Compressor Engine 05 - CAT G3516B (OxCat)	'12/'18	1,380 bhp	Modified	OxCat-05
EUCE-6	EPCE-6	CE-06	Compressor Engine 06 - CAT G3516B (OxCat)	'12/'18	1,380 bhp	Modified	OxCat-06
EUCE-7	EPCE-7	CE-07	Compressor Engine 07 - CAT G3516B (OxCat)	'12/'18	1,380 bhp	Modified	OxCat-07
EUCE-8	EPCE-8	CE-08	Compressor Engine 08 - CAT G3516B (OxCat)	'12/'18	1,380 bhp	Modified	OxCat-08
EUCE-9	EPCE-9	CE-09	Compressor Engine 09 - CAT G3516B (OxCat)	'12/'18	1,380 bhp	Modified	OxCat-09
EUCE-10	EPCE-10	CE-10	Compressor Engine 10 - CAT G3516B (OxCat)	'12/'18	1,380 bhp	Modified	OxCat-10
EUCE-11	EPCE-11	CE-11	Compressor Engine 11 - CAT G3516B (OxCat)	'12/'18	1,380 bhp	Modified	OxCat-11
EUCE-12	EPCE-12	CE-12	Compressor Engine 12 - CAT G3516B (OxCat)	'12/'18	1,380 bhp	Modified	OxCat-12
EUCRP	EPCRP	CRP	Compressor Rod Packing	'12/'18	12 Units	Modified	---
EUGEN-2	EPGEN-2	GEN	Generator Engine - Baldor IGLC420-2N (NSCR)	'12/'18	605 bhp	Modified	NSCR
EUDHY-1	EPSTL-1	DHY-01	Dehydrator 01 (BTEX Buster)	'12/'18	55.0 MMscfd	Modified	BTEX-01
EUDHY-2	EPSTL-2	DHY-02	Dehydrator 02 (BTEX Buster)	'12/'18	55.0 MMscfd	Modified	BTEX-02
EUDHY-3	EPSTL-3	DHY-03	Dehydrator 03 (BTEX Buster)	'12/'18	55.0 MMscfd	Modified	BTEX-03
EURBL-1	EPRBL-1	BLR-01	Reboiler 01	'12/'18	1.00 MMBtu/hr	Modified	---
EURBL-2	EPRBL-2	BLR-02	Reboiler 02	'12/'18	1.00 MMBtu/hr	Modified	---
EURBL-3	EPRBL-3	BLR-03	Reboiler 03	'12/'18	1.00 MMBtu/hr	Modified	---
EUHT-1	EPHT-1	HTR-01	Heater-Treater Burner 01	'12/'18	0.50 MMBtu/hr	Modified	---
EUHT-2	EPHT-2	HTR-02	Heater-Treater Burner 02	'12/'18	0.50 MMBtu/hr	Modified	---
EUTK-1	EPTK-1	TK-01	Storage Tank 01 - Stabilized Condensate (SC) (VRU)	'12/'18	400 bbl	Modified	VRU
EUTK-2	EPTK-2	TK-02	Storage Tank 02 - Stabilized Condensate (SC) (VRU)	'12/'18	400 bbl	Modified	VRU
EUTK-3	EPTK-3	TK-03	Storage Tank 03 - Stabilized Condensate (SC) (VRU)	'12/'18	400 bbl	Modified	VRU
EUTK-4	EPTK-4	TK-04	Storage Tank 04 - Stabilized Condensate (SC) (VRU)	'12/'18	400 bbl	Modified	VRU
EUTK-5	EPTK-5	TK-05	Storage Tank 05 - Stabilized Condensate (SC) (VRU)	'12/'18	400 bbl	Modified	VRU
EUTK-6	EPTK-6	TK-06	Storage Tank 06 - Stabilized Condensate (SC) (VRU)	'12/'18	400 bbl	Modified	VRU
EUTK-7	EPTK-7	TK-07	Storage Tank 07 - Stabilized Condensate (SC) (VRU)	'12/'18	400 bbl	Modified	VRU
EUTK-8	EPTK-8	TK-08	Storage Tank 08 - Stabilized Condensate (SC) (VRU)	'12/'18	400 bbl	Modified	VRU
EUWTK-9	EPWTK-9	WTK-01	Storage Tank W01 - Produced Water (PW)	'12/'18	400 bbl	Modified	---
EUWTK-10	EPWTK-10	WTK-02	Storage Tank W02 - Produced Water (PW)	'12/'18	400 bbl	Modified	---
EULOAD-1	EPLOAD-1	TLO	Truck Loading - Stabilized Condensate (SC) (CarbCan)	'12/'18	9,965 Mgal/yr	Modified	CarbCan
EULOAD-2	EPLOAD-2	WTLO	Truck Loading - Produced Water (PW)	'12/'18	1,533 Mgal/yr	Modified	---
EUBD	EPBD	CBD/ESD	Compressor Blowdown/Emergency Shutdown Tests	'12/'18	1,249 events/yr	Modified	---
EUPIG	EPIG	PIG	Pigging Operations	'12/'18	104 Events/yr	Modified	---
EUFUG	EPFUG	FUG-G	Piping & Equip Leaks - Gas	'12/'18	7,472 Units	Modified	---
		FUG-O	Piping & Equip Leaks - Light Liquid	'12/'18	3,407 Units	Modified	
EUECC	EPECC	ECC	Engine Crankcase Fugitives	'12/'18	17,165 bhp	Modified	---

¹ For Emission Units (or Sources) use the following numbering system: 1S, 2S, 3S, ... or other appropriate designation.

² For Emission Points use the following numbering system: 1E, 2E, 3E, ... or other appropriate designation.

³ New, modification, removal, etc.

⁴ For Control Devices use the following numbering system: 1C, 2C, 3C, ... or other appropriate designation.

Attachment J

Emission Points Data Summary Sheet

“26. Fill out the **Emission Points Data Summary Sheet** (Table 1 and Table 2) and provide it as Attachment J.”

- **Table 1 – Emissions Data**

- Compressor Engines – 1,380 bhp CAT G3516B (CE-01 thru CE-12)
- Generator Engine – 605 bhp Baldor IGLC420-2N (GEN)
- Compressor Rod Packing (CRP)
- Emergency Shutdown Testing (ESD)
- Dehydrators – 55.0 MMscfd (DHY-01 thru DHY-03)
- Reboilers – 1.00 MMscfd (BLR-01 thru BLR-03)
- Heater Treater – 0.50 MMBtu/hr (HTR-01 and HTR-02)
- Stabilized Condensate (SC) – 400 bbl Storage tanks (TK-01 thru TK-08)
- Produced Water (PW) – Storage Tanks (WTK-01 and WTK-02)
- Stabilized Condensate (SC) – Truck Loading (TLO)
- Produced Water (PW) Truck Loading (WTLO)
- Pigging Operations (PIG)
- PLANT-WIDE SUMMARY – w/o Fugitives
- PLANT-WIDE SUMMARY – with Fugitives

- **Table 2 – Release Parameter Data**

Attachment J
EMISSION POINTS DATA SUMMARY SHEET

Table 1: Emissions Data

Emission Point ID No. (Must match Emission Units Table & Plot Plan)	Emission Point Type ¹	Emission Unit Vented Through This Point (Must match Emission Units Table & Plot Plan)		Air Pollution Control Device (Must match Emission Units Table & Plot Plan)		Vent Time for Emission Unit (Chemical processes only)		All Regulated Pollutants - Chemical Name/CAS ³ (Speciate VOCs & HAPS)	Maximum Potential Uncontrolled Emissions ⁴		Maximum Potential Controlled Emissions ⁵		Emission Form or Phase (At exit conditions, Solid, Liquid or Gas/Vapor)	Est. Method Used ⁶	Emission Concentration ⁷ (ppmvd or mg/m ³)	
		ID No.	Source	ID No.	Device Type	Short Term ²	Max (hr/yr)		lb/hr	ton/yr	lb/hr	ton/yr				
EPCE-1 EPCE-2 EPCE-3 EPCE-4 EPCE-5 EPCE-6 EPCE-7 EPCE-8 EPCE-9 EPCE-10 EPCE-11 EPCE-12 (Each)	Upward Vertical Stack (Each)	Compressor Engine 01 thru 12 1,380 bhp CAT G3516B (w/ OxCat) (Each)						8,760 (Each)	NOX	1.52	6.66	1.52	6.66	Gas	Vendor	
		CO	9.43	41.31	1.41	6.20	Gas		Vendor							
		NMNEHC	3.16	13.86	0.63	2.77	Gas		Vendor							
		VOC	4.41	19.32	0.77	3.38	Gas		Vendor							
		PM10/2.5	0.11	0.49	0.11	0.49	S/L/G		AP-42							
		SO2	0.01	0.03	0.01	0.03	Gas		AP-42							
		Acetaldehyde	0.09	0.41	0.02	0.08	Gas		AP-42							
		Acrolein	0.06	0.25	0.01	0.05	Gas		AP-42							
		Benzene	5E-03	0.02	1E-03	4E-03	Gas		AP-42							
		Butadiene	3E-03	0.01	6E-04	3E-03	Gas		AP-42							
		Ethylbenzene	4E-04	2E-03	9E-05	4E-04	Gas		AP-42							
		HCHO	1.10	4.80	0.11	0.48	Gas		Vendor							
		n-Hexane	0.01	0.05	2E-03	0.01	Gas		AP-42							
		Methanol	0.03	0.12	0.01	0.02	Gas		AP-42							
		POM	4E-03	0.02	8E-04	3E-03	Gas		AP-42							
		Toluene	5E-03	0.02	9E-04	4E-03	Gas		AP-42							
		2,2,4-TMP	3E-03	0.01	6E-04	3E-03	Gas		AP-42							
		Xylenes	2E-03	0.01	4E-04	2E-03	Gas		AP-42							
		Other HAP	4E-03	0.02	7E-04	3E-03	Gas		AP-42							
		Total HAP	1.31	5.75	0.15	0.67	Gas		Sum							
		CO2	1,603	7,023	1,603	7,023	Gas		Vendor							
CH4	14.04	61.49	14.04	61.49	Gas	Vendor										
N2O	2E-03	0.01	2E-03	0.01	Gas	CFR98										
CO2e	1,955	8,563	1,955	8,563	Gas	Sum										

Attachment J
EMISSION POINTS DATA SUMMARY SHEET

Table 1: Emissions Data

Emission Point ID No. (Must match Emission Units Table & Plot Plan)	Emission Point Type ¹	Emission Unit Vented Through This Point (Must match Emission Units Table & Plot Plan)		Air Pollution Control Device (Must match Emission Units Table & Plot Plan)		Vent Time for Emission Unit (Chemical processes only)		All Regulated Pollutants - Chemical Name/CAS ³ (Speciate VOCs & HAPS)	Maximum Potential Uncontrolled Emissions ⁴		Maximum Potential Controlled Emissions ⁵		Emission Form or Phase (At exit conditions, Solid, Liquid or Gas/Vapor)	Est. Method Used ⁶	Emission Concentration ⁷ (ppmvd or mg/m ³)
		ID No.	Source	ID No.	Device Type	Short Term ²	Max (hr/yr)		lb/hr	ton/yr	lb/hr	ton/yr			
EPCRP-1 EPCRP-2 EPCRP-3 EPCRP-4 EPCRP-5 EPCRP-6 EPCRP-7 EPCRP-8 EPCRP-9 EPCRP-10 EPCRP-11 EPCRP-12 (Each)	Upward Vertical Stack	Compressor Rod Packing 01 thru 12 (Each)		na	na	C (Each)	8,760 (Each)	NOX	---	---	---	---	Gas	---	
		CO	---					---	---	---	Gas	---			
		NMNEHC	0.89					3.92	0.89	3.92	Gas	---			
		VOC	0.89					3.92	0.89	3.92	Gas	Vendor			
		PM10/2.5	---					---	---	---	S/L/G	---			
		SO2	---					---	---	---	Gas	---			
		Acetaldehyde	---					---	---	---	Gas	---			
		Acrolein	---					---	---	---	Gas	---			
		Benzene	1E-03					0.01	1E-03	0.01	Gas	MB			
		Butadiene	---					---	---	---	Gas	---			
		Ethylbenzene	1E-03					0.01	1E-03	0.01	Gas	MB			
		HCHO	---					---	---	---	Gas	---			
		n-Hexane	0.02					0.10	0.02	0.10	Gas	MB			
		Methanol	---					---	---	---	Gas	---			
		POM	---					---	---	---	Gas	---			
		Toluene	1E-03					0.01	1E-03	0.01	Gas	MB			
		2,2,4-TMP	1E-03					0.01	1E-03	0.01	Gas	MB			
		Xylenes	1E-03					0.01	1E-03	0.01	Gas	MB			
		Other HAP	---					---	---	---	Gas	---			
		Total HAP	0.03					0.13	0.03	0.13	Gas	Sum			
CO2	0.01	0.04	0.01	0.04	Gas	MB									
CH4	1.86	8.15	1.86	8.15	Gas	MB									
N2O	---	---	---	---	Gas	---									
CO2e	46.51	204	46.51	204	Gas	Sum									

Attachment J
EMISSION POINTS DATA SUMMARY SHEET

Table 1: Emissions Data

Emission Point ID No. (Must match Emission Units Table & Plot Plan)	Emission Point Type ¹	Emission Unit Vented Through This Point (Must match Emission Units Table & Plot Plan)		Air Pollution Control Device (Must match Emission Units Table & Plot Plan)		Vent Time for Emission Unit (Chemical processes only)		All Regulated Pollutants - Chemical Name/CAS ³ (Speciate VOCs & HAPS)	Maximum Potential Uncontrolled Emissions ⁴		Maximum Potential Controlled Emissions ⁵		Emission Form or Phase (At exit conditions, Solid, Liquid or Gas/Vapor)	Est. Method Used ⁶	Emission Concentration ⁷ (ppmvd or mg/m ³)								
		ID No.	Source	ID No.	Device Type	Short Term ²	Max (hr/yr)		lb/hr	ton/yr	lb/hr	ton/yr											
EPGEN-2	Upward Vertical Stack	EUGEN-2	GEN	NSCR	NSCR (3-Way)	C	8,760	NOX	10.01	43.85	1.33	5.84	Gas	Vendor									
								Generator Engine 605 bhp Baldor IGLC420-2N (w/ NSCR)								CO	16.85	73.81	2.67	11.68	Gas	Vendor	
								NMNEHC	0.93	4.09	0.93	4.09	Gas	Vendor									
								VOC	1.05	4.60	1.05	4.60	Gas	Vendor									
								PM10/2.5	0.09	0.39	0.09	0.39	S/L/G	AP-42									
								SO2	3E-03	0.01	3E-03	0.01	Gas	AP-42									
								Acetaldehyde	0.01	0.06	0.01	0.06	Gas	AP-42									
								Acrolein	0.01	0.05	0.01	0.05	Gas	AP-42									
								Benzene	0.01	0.03	0.01	0.03	Gas	AP-42									
								Butadiene	3E-03	0.01	3E-03	0.01	Gas	AP-42									
								Ethylbenzene	1E-04	5E-04	1E-04	5E-04	Gas	AP-42									
								HCHO	0.12	0.51	0.12	0.51	Gas	AP-42									
								n-Hexane	---	---	---	---	Gas	AP-42									
								Methanol	0.01	0.06	0.01	0.06	Gas	AP-42									
								POM	4E-04	2E-03	4E-04	2E-03	Gas	AP-42									
								Toluene	3E-03	0.01	3E-03	0.01	Gas	AP-42									
								2,2,4-TMP	---	---	---	---	Gas	AP-42									
								Xylenes	9E-04	4E-03	9E-04	4E-03	Gas	AP-42									
								Other HAP	8E-04	4E-03	8E-04	4E-03	Gas	AP-42									
								Total HAP	0.17	0.75	0.17	0.75	Gas	Sum									
CO2	498	2,183	498	2,183	Gas	AP-42																	
CH4	1.04	4.56	1.04	4.56	Gas	AP-42																	
N2O	1E-03	4E-03	1E-03	4E-03	Gas	CFR98																	
CO2e	525	2,298	525	2,298	Gas	Sum																	

WVDEP-DAQ Revision 2/11

Attachment J
EMISSION POINTS DATA SUMMARY SHEET

Table 1: Emissions Data

Emission Point ID No. (Must match Emission Units Table & Plot Plan)	Emission Point Type ¹	Emission Unit Vented Through This Point (Must match Emission Units Table & Plot Plan)		Air Pollution Control Device (Must match Emission Units Table & Plot Plan)		Vent Time for Emission Unit (Chemical processes only)		All Regulated Pollutants - Chemical Name/CAS ³ (Speciate VOCs & HAPS)	Maximum Potential Uncontrolled Emissions ⁴		Maximum Potential Controlled Emissions ⁵		Emission Form or Phase (At exit conditions, Solid, Liquid or Gas/Vapor)	Est. Method Used ⁶	Emission Concentration ⁷ (ppmvd or mg/m ³)	
		ID No.	Source	ID No.	Device Type	Short Term ²	Max (hr/yr)		lb/hr	ton/yr	lb/hr	ton/yr				
EPDHY-1 EPDHY-2 EPDHY-3 (Each)	Upward Vertical Stack (Each)	EUDHY-1 EUDHY-2 EUDHY-3 (Each)	DHY-01 DHY-02 DHY-03 (Each)	BTEX-01 BTEX-02 BTEX-03 (Each)	Cond/ Comb (Each)	C (Each)	8,760 (Each)	NOX	See BLR-01 thru BLR-03							
								CO	See BLR-01 thru BLR-03							
								NMNEHC	49.21	215.55	1.89	8.29	Gas	GLYCalc		
								VOC	49.21	215.55	1.89	8.29	Gas	GLYCalc		
								PM10/2.5	See BLR-01 thru BLR-03							
								SO2	See BLR-01 thru BLR-03							
								Acetaldehyde	See BLR-01 thru BLR-03							
								Acrolein	See BLR-01 thru BLR-03							
								Benzene	1.69	7.39	0.07	0.29	Gas	GLYCalc		
								Butadiene	See BLR-01 thru BLR-03							
								Ethylbenzene	0.31	1.34	5E-03	0.02	Gas	GLYCalc		
								HCHO	See BLR-01 thru BLR-03							
								n-Hexane	2.33	10.19	0.10	0.43	Gas	GLYCalc		
								Methanol	See BLR-01 thru BLR-03							
								POM	See BLR-01 thru BLR-03							
								Toluene	3.38	14.79	0.09	0.41	Gas	GLYCalc		
								2,2,4-TMP	0.23	1.00	2E-03	0.01	Gas	GLYCalc		
								Xylenes	2.81	12.29	0.04	0.17	Gas	GLYCalc		
								Other HAP	See BLR-01 thru BLR-03							
								Total HAP	10.73	46.99	0.30	1.34	Gas	Sum		
								CO2	0.60	2.64	0.60	2.64	Gas	GLYCalc		
								CH4	1.71	7.49	0.09	0.37	Gas	GLYCalc		
								N2O	See BLR-01 thru BLR-03							
CO2e	43.36	189.94	2.74	12.00	Gas	Sum										

WVDEP-DAQ Revision 2/11

Attachment J
EMISSION POINTS DATA SUMMARY SHEET

Table 1: Emissions Data

Emission Point ID No. (Must match Emission Units Table & Plot Plan)	Emission Point Type ¹	Emission Unit Vented Through This Point (Must match Emission Units Table & Plot Plan)		Air Pollution Control Device (Must match Emission Units Table & Plot Plan)		Vent Time for Emission Unit (Chemical processes only)		All Regulated Pollutants - Chemical Name/CAS ³ (Speciate VOCs & HAPS)	Maximum Potential Uncontrolled Emissions ⁴		Maximum Potential Controlled Emissions ⁵		Emission Form or Phase (At exit conditions, Solid, Liquid or Gas/Vapor)	Est. Method Used ⁶	Emission Concentration ⁷ (ppmvd or mg/m ³)
		ID No.	Source	ID No.	Device Type	Short Term ²	Max (hr/yr)		lb/hr	ton/yr	lb/hr	ton/yr			
EPRBL-1 EPRBL-2 EPRBL-3 (Each)	Upward Vertical Stack (Each)	Reboiler 01 thru 03 1.00 MMBtu/hr (Each)		na	na	C (Each)	8,760 (Each)	NOX	0.10	0.43	0.10	0.43	Gas	AP-42	
		CO	0.08					0.36	0.08	0.36	Gas	AP-42			
		NMNEHC	0.01					0.02	0.01	0.02	Gas	AP-42			
		VOC	0.01					0.02	0.01	0.02	Gas	AP-42			
		PM10/2.5	0.01					0.03	0.01	0.03	S/L/G	AP-42			
		SO2	6E-04					3E-03	6E-04	3E-03	Gas	AP-42			
		Acetaldehyde	---					---	---	---	Gas	AP-42			
		Acrolein	---					---	---	---	Gas	AP-42			
		Benzene	2E-06					9E-06	2E-06	9E-06	Gas	AP-42			
		Butadiene	---					---	---	---	Gas	AP-42			
		Ethylbenzene	---					---	---	---	Gas	AP-42			
		HCHO	7E-05					3E-04	7E-05	3E-04	Gas	AP-42			
		n-Hexane	2E-03					0.01	2E-03	0.01	Gas	AP-42			
		Methanol	---					---	---	---	Gas	AP-42			
		POM	7E-07					3E-06	7E-07	3E-06	Gas	AP-42			
		Toluene	3E-06					1E-05	3E-06	1E-05	Gas	AP-42			
		2,2,4-TMP	---					---	---	---	Gas	AP-42			
		Xylenes	---					---	---	---	Gas	AP-42			
		Other HAP	1E-06					5E-06	1E-06	5E-06	Gas	AP-42			
		Total HAP	2E-03					0.01	2E-03	0.01	Gas	Sum			
		CO2	118					515	118	515	Gas	AP-42			
CH4	2E-03	0.01	2E-03	0.01	Gas	AP-42									
N2O	2E-03	0.01	2E-03	0.01	Gas	AP-42									
CO2e	118	518	118	518	Gas	Sum									

WVDEP-DAQ Revision 2/11

Attachment J
EMISSION POINTS DATA SUMMARY SHEET

Table 1: Emissions Data

Emission Point ID No. (Must match Emission Units Table & Plot Plan)	Emission Point Type ¹	Emission Unit Vented Through This Point (Must match Emission Units Table & Plot Plan)		Air Pollution Control Device (Must match Emission Units Table & Plot Plan)		Vent Time for Emission Unit (Chemical processes only)		All Regulated Pollutants - Chemical Name/CAS ³ (Speciate VOCs & HAPS)	Maximum Potential Uncontrolled Emissions ⁴		Maximum Potential Controlled Emissions ⁵		Emission Form or Phase (At exit conditions, Solid, Liquid or Gas/Vapor)	Est. Method Used ⁶	Emission Concentration ⁷ (ppmvd or mg/m ³)
		ID No.	Source	ID No.	Device Type	Short Term ²	Max (hr/yr)		lb/hr	ton/yr	lb/hr	ton/yr			
EPHT-1 EPHT-2 (Each)	Upward Vertical Stack (Each)	Heater Treater 01 and 02 0.50 MMBtu/hr (Each)		na	na	C (Each)	8,760 (Each)	NOX	0.06	0.21	0.06	0.21	Gas	AP-42	
								CO	0.05	0.18	0.05	0.18	Gas	AP-42	
		NMNEHC	3E-03					0.01	3E-03	0.01	Gas	AP-42			
		VOC	3E-03					0.01	3E-03	0.01	Gas	AP-42			
		PM10/2.5	5E-03					0.02	5E-03	0.02	S/L/G	AP-42			
		SO2	4E-04					1E-03	4E-04	1E-03	Gas	AP-42			
		Acetaldehyde	---					---	---	---	Gas	AP-42			
		Acrolein	---					---	---	---	Gas	AP-42			
		Benzene	1E-06					5E-06	1E-06	5E-06	Gas	AP-42			
		Butadiene	---					---	---	---	Gas	AP-42			
		Ethylbenzene	---					---	---	---	Gas	AP-42			
		HCHO	5E-05					2E-04	5E-05	2E-04	Gas	AP-42			
		n-Hexane	1E-03					4E-03	1E-03	4E-03	Gas	AP-42			
		Methanol	---					---	---	---	Gas	AP-42			
		POM	4E-07					1E-06	4E-07	1E-06	Gas	AP-42			
		Toluene	2E-06					7E-06	2E-06	7E-06	Gas	AP-42			
		2,2,4-TMP	---					---	---	---	Gas	AP-42			
		Xylenes	---					---	---	---	Gas	AP-42			
		Other HAP	7E-07					3E-06	7E-07	3E-06	Gas	AP-42			
		Total HAP	1E-03					4E-03	1E-03	4E-03	Gas	Sum			
CO2	72	258	72	258	Gas	AP-42									
CH4	1E-03	5E-03	1E-03	5E-03	Gas	AP-42									
N2O	1E-03	5E-03	1E-03	5E-03	Gas	AP-42									
CO2e	59	259	59	259	Gas	Sum									

WVDEP-DAQ Revision 2/11

Attachment J
EMISSION POINTS DATA SUMMARY SHEET

Table 1: Emissions Data

Emission Point ID No. (Must match Emission Units Table & Plot Plan)	Emission Point Type ¹	Emission Unit Vented Through This Point (Must match Emission Units Table & Plot Plan)		Air Pollution Control Device (Must match Emission Units Table & Plot Plan)		Vent Time for Emission Unit (Chemical processes only)		All Regulated Pollutants - Chemical Name/CAS ³ (Speciate VOCs & HAPS)	Maximum Potential Uncontrolled Emissions ⁴		Maximum Potential Controlled Emissions ⁵		Emission Form or Phase (At exit conditions, Solid, Liquid or Gas/Vapor)	Est. Method Used ⁶	Emission Concentration ⁷ (ppmvd or mg/m ³)		
		ID No.	Source	ID No.	Device Type	Short Term ²	Max (hr/yr)		lb/hr	ton/yr	lb/hr	ton/yr					
EPTK-1 EPTK-2 EPTK-3 EPTK-4 EPTK-5 EPTK-6 EPTK-7 EPTK-8 (Each)	Upward Vertical Stack (Each)	Stabilized Condensate (SC) Tanks 01 thru 08 400 bbl Each						C (Each)	8,760 (Each)	NOX	---	---	---	---	Gas	---	
		CO	---	---	---	---	---			Gas	---						
		NMNEHC	0.77	3.37	0.04	0.17	Gas			T4.0.9D							
		VOC	0.77	3.37	0.04	0.17	Gas			T4.0.9D							
		PM10/2.5	---	---	---	---	S/L/G			---							
		SO2	---	---	---	---	Gas			---							
		Acetaldehyde	---	---	---	---	Gas			---							
		Acrolein	---	---	---	---	Gas			---							
		Benzene	0.02	0.07	8E-04	0.00	Gas			MB							
		Butadiene	---	---	---	---	Gas			---							
		Ethylbenzene	0.02	0.07	8E-04	0.00	Gas			MB							
		HCHO	---	---	---	---	Gas			---							
		n-Hexane	0.15	0.67	0.01	0.03	Gas			MB							
		Methanol	---	---	---	---	Gas			---							
		POM	---	---	---	---	Gas			---							
		Toluene	0.02	0.07	8E-04	0.00	Gas			MB							
		2,2,4-TMP	0.02	0.07	8E-04	0.00	Gas			MB							
		Xylenes	0.02	0.07	8E-04	0.00	Gas			---							
		Other HAP	---	---	---	---	Gas			---							
		Total HAP	0.23	1.01	0.01	0.05	Gas			Sum							
CO2	---	---	---	---	Gas	MB											
CH4	---	---	---	---	Gas	MB											
N2O	---	---	---	---	Gas	---											
CO2e	---	---	---	---	Gas	Sum											

Attachment J
EMISSION POINTS DATA SUMMARY SHEET

Table 1: Emissions Data

Emission Point ID No. (Must match Emission Units Table & Plot Plan)	Emission Point Type ¹	Emission Unit Vented Through This Point (Must match Emission Units Table & Plot Plan)		Air Pollution Control Device (Must match Emission Units Table & Plot Plan)		Vent Time for Emission Unit (Chemical processes only)		All Regulated Pollutants - Chemical Name/CAS ³ (Speciate VOCs & HAPS)	Maximum Potential Uncontrolled Emissions ⁴		Maximum Potential Controlled Emissions ⁵		Emission Form or Phase (At exit conditions, Solid, Liquid or Gas/Vapor)	Est. Method Used ⁶	Emission Concentration ⁷ (ppmvd or mg/m ³)
		ID No.	Source	ID No.	Device Type	Short Term ²	Max (hr/yr)		lb/hr	ton/yr	lb/hr	ton/yr			
EPWTK-1 EPWTK-2 (Each)	Upward Vertical Stack (Each)	Produced Water (PW) Tanks 01 and 02 400 bbl Each		na	na	C (Each)	8,760 (Each)	NOX	---	---	---	---	Gas	---	
								CO	---	---	---	---	Gas	---	
		NMNEHC	0.01					0.03	0.01	0.03	Gas	T4.0.9D			
		VOC	0.01					0.03	0.01	0.03	Gas	T4.0.9D			
		PM10/2.5	---					---	---	---	S/L/G	---			
		SO2	---					---	---	---	Gas	---			
		Acetaldehyde	---					---	---	---	Gas	---			
		Acrolein	---					---	---	---	Gas	---			
		Benzene	1E-04					6E-04	1E-04	6E-04	Gas	MB			
		Butadiene	---					---	---	---	Gas	---			
		Ethylbenzene	1E-04					6E-04	1E-04	6E-04	Gas	MB			
		HCHO	---					---	---	---	Gas	---			
		n-Hexane	1E-03					0.01	1E-03	0.01	Gas	MB			
		Methanol	---					---	---	---	Gas	---			
		POM	---					---	---	---	Gas	---			
		Toluene	1E-04					6E-04	1E-04	6E-04	Gas	MB			
		2,2,4-TMP	1E-04					6E-04	1E-04	6E-04	Gas	MB			
		Xylenes	1E-04					6E-04	1E-04	6E-04	Gas	---			
		Other HAP	---					---	---	---	Gas	---			
		Total HAP	2E-03					0.01	2E-03	0.01	Gas	Sum			
CO2	---	---	---	---	Gas	MB									
CH4	---	---	---	---	Gas	MB									
N2O	---	---	---	---	Gas	---									
CO2e	---	---	---	---	Gas	Sum									

Attachment J
EMISSION POINTS DATA SUMMARY SHEET

Table 1: Emissions Data

Emission Point ID No. (Must match Emission Units Table & Plot Plan)	Emission Point Type ¹	Emission Unit Vented Through This Point (Must match Emission Units Table & Plot Plan)		Air Pollution Control Device (Must match Emission Units Table & Plot Plan)		Vent Time for Emission Unit (Chemical processes only)		All Regulated Pollutants - Chemical Name/CAS ³ (Speciate VOCs & HAPS)	Maximum Potential Uncontrolled Emissions ⁴		Maximum Potential Controlled Emissions ⁵		Emission Form or Phase (At exit conditions, Solid, Liquid or Gas/Vapor)	Est. Method Used ⁶	Emission Concentration ⁷ (ppmvd or mg/m ³)								
		ID No.	Source	ID No.	Device Type	Short Term ²	Max (hr/yr)		lb/hr	ton/yr	lb/hr	ton/yr											
EPL0AD-1	Upward Vertical Stack	EULOAD-1	TLO	CARB-01	Carbon Can-nister	7,000 gal/hr	1,424	NOX	---	---	---	---	Gas	---									
								CO	---	---	---	---	Gas	---									
								Stabilized Condensate (SC) Truck Load-Out								NMNEHC	35.72	25.43	11.97	8.52	Gas	AP-42	
								VOC	35.72	25.43	11.97	8.52	Gas	AP-42									
								PM10/2.5	---	---	---	---	S/L/G	---									
								SO2	---	---	---	---	Gas	---									
								Acetaldehyde	---	---	---	---	Gas	---									
								Acrolein	---	---	---	---	Gas	---									
								Benzene	0.71	0.51	0.24	0.17	Gas	MB									
								Butadiene	---	---	---	---	Gas	---									
								Ethylbenzene	0.71	0.51	0.24	0.17	Gas	MB									
								HCHO	---	---	---	---	Gas	---									
								n-Hexane	7.14	5.09	2.39	1.70	Gas	MB									
								Methanol	---	---	---	---	Gas	---									
								POM	---	---	---	---	Gas	---									
								Toluene	0.71	0.51	0.24	0.17	Gas	MB									
								2,2,4-TMP	0.71	0.51	0.24	0.17	Gas	MB									
								Xylenes	0.71	0.51	0.24	0.17	Gas	---									
								Other HAP	---	---	---	---	Gas	---									
								Total HAP	10.72	7.63	3.59	2.56	Gas	Sum									
CO2	---	---	---	---	Gas	---																	
CH4	---	---	---	---	Gas	---																	
N2O	---	---	---	---	Gas	---																	
CO2e	---	---	---	---	Gas	---																	

WVDEP-DAQ Revision 2/11

Attachment J
EMISSION POINTS DATA SUMMARY SHEET

Table 1: Emissions Data

Emission Point ID No. (Must match Emission Units Table & Plot Plan)	Emission Point Type ¹	Emission Unit Vented Through This Point (Must match Emission Units Table & Plot Plan)		Air Pollution Control Device (Must match Emission Units Table & Plot Plan)		Vent Time for Emission Unit (Chemical processes only)		All Regulated Pollutants - Chemical Name/CAS ³ (Speciate VOCs & HAPS)	Maximum Potential Uncontrolled Emissions ⁴		Maximum Potential Controlled Emissions ⁵		Emission Form or Phase (At exit conditions, Solid, Liquid or Gas/Vapor)	Est. Method Used ⁶	Emission Concentration ⁷ (ppmvd or mg/m ³)
		ID No.	Source	ID No.	Device Type	Short Term ²	Max (hr/yr)		lb/hr	ton/yr	lb/hr	ton/yr			
EPLOAD-2	Upward Vertical Stack	Produced Water (PW) Truck Load-Out		na	na	7,000 gal/hr	219	NOX	---	---	---	---	Gas	---	
								CO	---	---	---	---	Gas	---	
		NMNEHC	0.72					0.08	0.72	0.08	Gas	AP-42			
		VOC	0.72					0.08	0.72	0.08	Gas	AP-42			
		PM10/2.5	---					---	---	---	S/L/G	---			
		SO2	---					---	---	---	Gas	---			
		Acetaldehyde	---					---	---	---	Gas	---			
		Acrolein	---					---	---	---	Gas	---			
		Benzene	0.01					2E-03	0.01	2E-03	Gas	MB			
		Butadiene	---					---	---	---	Gas	---			
		Ethylbenzene	0.01					2E-03	0.01	2E-03	Gas	MB			
		HCHO	---					---	---	---	Gas	---			
		n-Hexane	0.14					0.02	0.14	0.02	Gas	MB			
		Methanol	---					---	---	---	Gas	---			
		POM	---					---	---	---	Gas	---			
		Toluene	0.01					2E-03	0.01	2E-03	Gas	MB			
		2,2,4-TMP	0.01					2E-03	0.01	2E-03	Gas	MB			
		Xylenes	0.01					2E-03	0.01	2E-03	Gas	---			
		Other HAP	---					---	---	---	Gas	---			
		Total HAP	0.22					0.02	0.22	0.02	Gas	Sum			
		CO2	---					---	---	---	Gas	---			
CH4	---	---	---	---	Gas	---									
N2O	---	---	---	---	Gas	---									
CO2e	---	---	---	---	Gas	---									

WVDEP-DAQ Revision 2/11

Attachment J
EMISSION POINTS DATA SUMMARY SHEET

Table 1: Emissions Data

Emission Point ID No. (Must match Emission Units Table & Plot Plan)	Emission Point Type ¹	Emission Unit Vented Through This Point (Must match Emission Units Table & Plot Plan)		Air Pollution Control Device (Must match Emission Units Table & Plot Plan)		Vent Time for Emission Unit (Chemical processes only)		All Regulated Pollutants - Chemical Name/CAS ³ (Speciate VOCs & HAPS)	Maximum Potential Uncontrolled Emissions ⁴		Maximum Potential Controlled Emissions ⁵		Emission Form or Phase (At exit conditions, Solid, Liquid or Gas/Vapor)	Est. Method Used ⁶	Emission Concentration ⁷ (ppmvd or mg/m ³)
		ID No.	Source	ID No.	Device Type	Short Term ²	Max (hr/yr)		lb/hr	ton/yr	lb/hr	ton/yr			
EPCBD-1 EPCBD-2 EPCBD-3 EPCBD-4 EPCBD-5 EPCBD-6 EPCBD-7 EPCBD-8 EPCBD-9 EPCBD-10 EPCBD-11 EPCBD-12 (Each)	Upward Vertical Stack	Compressor Blowdown (CBD) (Each)		na	na	C (Each)	104 (Each)	NOX	---	---	---	---	Gas	---	
		CO	---					---	---	---	Gas	---			
		NMNEHC	30.78					1.60	30.78	1.60	Gas	MB			
		VOC	30.78					1.60	30.78	1.60	Gas	MB			
		PM10/2.5	---					---	---	---	S/L/G	---			
		SO2	---					---	---	---	Gas	---			
		Acetaldehyde	---					---	---	---	Gas	---			
		Acrolein	---					---	---	---	Gas	---			
		Benzene	0.05					2E-03	0.05	2E-03	Gas	MB			
		Butadiene	---					---	---	---	Gas	---			
		Ethylbenzene	0.05					2E-03	0.05	2E-03	Gas	MB			
		HCHO	---					---	---	---	Gas	---			
		n-Hexane	0.76					0.04	0.76	0.04	Gas	MB			
		Methanol	---					---	---	---	Gas	---			
		POM	---					---	---	---	Gas	---			
		Toluene	0.05					2E-03	0.05	2E-03	Gas	MB			
		2,2,4-TMP	0.05					2E-03	0.05	2E-03	Gas	MB			
		Xylenes	0.05					2E-03	0.05	2E-03	Gas	MB			
		Other HAP	---					---	---	---	Gas	---			
		Total HAP	1.00					0.05	1.00	0.05	Gas	Sum			
CO2	0.29	0.01	0.29	0.01	Gas	MB									
CH4	64.03	3.33	64.03	3.33	Gas	MD									
N2O	---	---	---	---	Gas	---									
CO2e	1,601	83.25	1,601	83.25	Gas	Sum									

WVDEP-DAQ Revision 2/11

Attachment J
EMISSION POINTS DATA SUMMARY SHEET

Table 1: Emissions Data

Emission Point ID No. (Must match Emission Units Table & Plot Plan)	Emission Point Type ¹	Emission Unit Vented Through This Point (Must match Emission Units Table & Plot Plan)		Air Pollution Control Device (Must match Emission Units Table & Plot Plan)		Vent Time for Emission Unit (Chemical processes only)		All Regulated Pollutants - Chemical Name/CAS ³ (Speciate VOCs & HAPS)	Maximum Potential Uncontrolled Emissions ⁴		Maximum Potential Controlled Emissions ⁵		Emission Form or Phase (At exit conditions, Solid, Liquid or Gas/Vapor)	Est. Method Used ⁶	Emission Concentration ⁷ (ppmvd or mg/m ³)								
		ID No.	Source	ID No.	Device Type	Short Term ²	Max (hr/yr)		lb/hr	ton/yr	lb/hr	ton/yr											
ESD (Subset of CBD)	Upward Vertical Stack	ESD (Subset of CBD)	ESD (Subset of CBD)	na	na	1 event/yr	na	NOX	---	---	---	---	Gas	---									
								CO	---	---	---	---	Gas	---									
								Emergency Shutdown (ESD) Testing (Subset of Compressor Bowdown (CBD))								NMNEHC	---	7.90	---	7.90	Gas	MB	
								VOC	---	7.90	---	7.90	Gas	MB									
								PM10/2.5	---	---	---	---	S/L/G	---									
								SO2	---	---	---	---	Gas	---									
								Acetaldehyde	---	---	---	---	Gas	---									
								Acrolein	---	---	---	---	Gas	---									
								Benzene	---	0.01	---	0.01	Gas	MB									
								Butadiene	---	---	---	---	Gas	---									
								Ethylbenzene	---	0.01	---	0.01	Gas	MB									
								HCHO	---	---	---	---	Gas	---									
								n-Hexane	---	0.20	---	0.20	Gas	MB									
								Methanol	---	---	---	---	Gas	---									
								POM	---	---	---	---	Gas	---									
								Toluene	---	0.01	---	0.01	Gas	MB									
								2,2,4-TMP	---	0.01	---	0.01	Gas	MB									
								Xylenes	---	0.01	---	0.01	Gas	MB									
								Other HAP	---	---	---	---	Gas	---									
								Total HAP	---	0.26	---	0.26	Gas	Sum									
CO2	---	0.07	---	0.07	Gas	MB																	
CH4	---	16.44	---	16.44	Gas	MD																	
N2O	---	---	---	---	Gas	---																	
CO2e	---	411	---	411	Gas	Sum																	

WVDEP-DAQ Revision 2/11

Attachment J
EMISSION POINTS DATA SUMMARY SHEET

Table 1: Emissions Data

Emission Point ID No. (Must match Emission Units Table & Plot Plan)	Emission Point Type ¹	Emission Unit Vented Through This Point (Must match Emission Units Table & Plot Plan)		Air Pollution Control Device (Must match Emission Units Table & Plot Plan)		Vent Time for Emission Unit (Chemical processes only)		All Regulated Pollutants - Chemical Name/CAS ³ (Speciate VOCs & HAPS)	Maximum Potential Uncontrolled Emissions ⁴		Maximum Potential Controlled Emissions ⁵		Emission Form or Phase (At exit conditions, Solid, Liquid or Gas/Vapor)	Est. Method Used ⁶	Emission Concentration ⁷ (ppmvd or mg/m ³)
		ID No.	Source	ID No.	Device Type	Short Term ²	Max (hr/yr)		lb/hr	ton/yr	lb/hr	ton/yr			
PIG	Upward Vertical Stack	Pigging (PIG)		na	na	1 event/yr	104	NOX	---	---	---	---	Gas	---	
		CO	---					---	---	---	Gas	---			
		NMNEHC	131.75					4.12	131.75	4.12	Gas	MB			
		VOC	131.75					4.12	131.75	4.12	Gas	MB			
		PM10/2.5	---					---	---	---	S/L/G	---			
		SO2	---					---	---	---	Gas	---			
		Acetaldehyde	---					---	---	---	Gas	---			
		Acrolein	---					---	---	---	Gas	---			
		Benzene	0.20					0.01	0.20	0.01	Gas	MB			
		Butadiene	---					---	---	---	Gas	---			
		Ethylbenzene	0.20					0.01	0.20	0.01	Gas	MB			
		HCHO	---					---	---	---	Gas	---			
		n-Hexane	3.25					0.10	3.25	0.08	Gas	MB			
		Methanol	---					---	---	---	Gas	---			
		POM	---					---	---	---	Gas	---			
		Toluene	0.20					0.01	0.20	0.01	Gas	MB			
		2,2,4-TMP	0.20					0.01	0.20	0.01	Gas	MB			
		Xylenes	0.20					0.01	0.20	0.01	Gas	MB			
		Other HAP	---					---	---	---	Gas	---			
		Total HAP	4.27					0.13	4.27	0.11	Gas	Sum			
CO2	1.22	0.04	1.22	0.04	Gas	MB									
CH4	274	8.57	274	8.57	Gas	MD									
N2O	---	---	---	---	Gas	---									
CO2e	6,853	214	6853	214	Gas	Sum									

**Attachment J
EMISSION POINTS DATA SUMMARY SHEET**

Table 1: Emissions Data

Emission Point ID No. (Must match Emission Units Table & Plot Plan)	Emission Point Type ¹	Emission Unit Vented Through This Point (Must match Emission Units Table & Plot Plan)		Air Pollution Control Device (Must match Emission Units Table & Plot Plan)		Vent Time for Emission Unit (Chemical processes only)		All Regulated Pollutants - Chemical Name/CAS ³ (Speciate VOCs & HAPS)	Maximum Potential Uncontrolled Emissions ⁴		Maximum Potential Controlled Emissions ⁵		Emission Form or Phase (At exit conditions, Solid, Liquid or Gas/Vapor)	Est. Method Used ⁶	Emission Concentration ⁷ (ppmvd or mg/m ³)	
		ID No.	Source	ID No.	Device Type	Short Term ²	Max (hr/yr)		lb/hr	ton/yr	lb/hr	ton/yr				
PLANT-WIDE SUMMARY (w/o Fugitives)									NOX	28.68	125.52	20.00	87.51	Gas	Varies	
									CO	130.38	570.97	19.99	87.48	Gas	Varies	
									NMNEHC	741	948	539	150.56	Gas	Varies	
									VOC	756	1,014	541	158.43	Gas	Varies	
									PM10/2.5	1.47	6.41	1.47	6.41	S/L/G	AP-42	
									SO2	0.08	0.37	0.08	0.37	Gas	AP-42	
									Acetaldehyde	1.14	4.99	0.24	1.04	Gas	AP-42	
									Acrolein	0.70	3.09	0.15	0.66	Gas	AP-42	
									Benzene	6.77	23.64	1.27	1.28	Gas	Varies	
									Butadiene	0.04	0.17	0.01	0.04	Gas	AP-42	
									Ethylbenzene	2.56	5.21	1.07	0.39	Gas	Varies	
									HCHO	13.26	58.08	1.43	6.27	Gas	Varies	
									n-Hexane	28.29	43.68	15.57	5.37	Gas	Varies	
									Methanol	0.35	1.54	0.08	0.36	Gas	AP-42	
									POM	0.05	0.21	0.01	0.04	Gas	AP-42	
									Toluene	11.83	45.79	1.34	1.60	Gas	Varies	
									2,2,4-TMP	2.36	4.33	1.06	0.38	Gas	Varies	
									Xylenes	10.09	38.15	1.17	0.86	Gas	Varies	
									Other HAP	0.04	0.19	0.01	0.04	Gas	AP-42	
									Total HAP	77.49	229.06	23.42	18.34	Gas	Sum	
									CO2	20,242	88,524	20,242	88,524	Gas	Varies	
									CH4	1,239	928	1,235	906	Gas	Varies	
									N2O	0.04	0.17	0.04	0.17	Gas	40CFR98	
									CO2e	51,212	111,767	51,090	111,233	Gas	sum	

WVDEP-DAQ Revision 2/11

Attachment J
EMISSION POINTS DATA SUMMARY SHEET

Table 1: Emissions Data

Emission Point ID No. (Must match Emission Units Table & Plot Plan)	Emission Point Type ¹	Emission Unit Vented Through This Point (Must match Emission Units Table & Plot Plan)		Air Pollution Control Device (Must match Emission Units Table & Plot Plan)		Vent Time for Emission Unit (Chemical processes only)		All Regulated Pollutants - Chemical Name/CAS ³ (Speciate VOCs & HAPS)	Maximum Potential Uncontrolled Emissions ⁴		Maximum Potential Controlled Emissions ⁵		Emission Form or Phase (At exit conditions, Solid, Liquid or Gas/Vapor)	Est. Method Used ⁶	Emission Concentration ⁷ (ppmvd or mg/m ³)	
		ID No.	Source	ID No.	Device Type	Short Term ²	Max (hr/yr)		lb/hr	ton/yr	lb/hr	ton/yr				
PLANT-WIDE SUMMARY (with Fugitives)									NOX	28.73	125.73	20.05	87.72	Gas	Varies	
									CO	130.67	572.25	20.28	88.76	Gas	Varies	
									NMNEHC	754	1,003	552	205.44	Gas	Varies	
									VOC	769	1,069	553	213.31	Gas	Varies	
									PM10/2.5	1.47	6.43	1.47	6.43	S/LG	AP-42	
									SO2	0.08	0.37	0.08	0.37	Gas	AP-42	
									Acetaldehyde	1.14	5.00	0.24	1.06	Gas	AP-42	
									Acrolein	0.71	3.09	0.15	0.67	Gas	AP-42	
									Benzene	6.79	23.72	1.29	1.36	Gas	Varies	
									Butadiene	0.04	0.17	0.01	0.05	Gas	AP-42	
									Ethylbenzene	2.58	5.29	1.08	0.47	Gas	Varies	
									HCHO	13.29	58.23	1.47	6.42	Gas	Varies	
									n-Hexane	28.60	45.02	15.88	6.72	Gas	Varies	
									Methanol	0.35	1.54	0.08	0.36	Gas	AP-42	
									POM	0.05	0.21	0.01	0.04	Gas	AP-42	
									Toluene	11.85	45.87	1.34	1.69	Gas	Varies	
									2,2,4-TMP	2.38	4.41	1.08	0.47	Gas	Varies	
									Xylenes	10.10	38.24	1.19	0.95	Gas	Varies	
									Other HAP	0.04	0.19	0.01	0.04	Gas	AP-42	
									Total HAP	77.93	231.00	23.86	20.28	Gas	Sum	
									CO2	20,292	88,742	20,292	88,742	Gas	Varies	
									CH4	1,250	975	1,245	953	Gas	Varies	
									N2O	0.04	0.17	0.04	0.17	Gas	40CFR98	
									CO2e	51,529	113,156	51,407	112,622	Gas	sum	

WVDEP-DAQ Revision 2/11

Attachment J
EMISSION POINTS DATA SUMMARY SHEET - Continued

Table 1: Emissions Data - Continued

The EMISSION POINTS DATA SUMMARY SHEET provides a summation of emissions by emission unit. Note that uncaptured process emission unit emissions are not typically considered to be fugitive and must be accounted for on the appropriate EMISSIONS UNIT DATA SHEET and on the EMISSION POINTS DATA SUMMARY SHEET. Please note that total emissions from the source are equal to all vented emissions, all fugitive emissions, plus all other emissions (e.g. uncaptured emissions). Please complete the FUGITIVE EMISSIONS DATA SUMMARY SHEET for fugitive emission activities.

- 1 Please add descriptors such as upward vertical stack, downward vertical stack, horizontal stack, relief vent, rain cap, etc.
- 2 Indicate by "C" if venting is continuous. Otherwise, specify the average short-term venting rate with units, for intermittent venting (ie., 15 min/hr). Indicate as many rates as needed to clarify frequency of venting (e.g., 5 min/day, 2 days/wk).
- 3 List all regulated air pollutants. Speciate VOCs, including all HAPs. Follow chemical name with Chemical Abstracts Service (CAS) number. LIST Acids, CO, CS₂, VOCs, H₂S, Inorganics, Lead, Organics, O₃, NO, NO₂, SO₂, SO₃, all applicable Greenhouse Gases (including CO₂ and methane), etc. DO NOT LIST H₂, H₂O, N₂, O₂, and Noble Gases.
- 4 Give maximum potential emission rate with no control equipment operating. If emissions occur for less than 1 hr, then record emissions per batch in minutes (e.g. 5 lb VOC/20 minute batch).
- 5 Give maximum potential emission rate with proposed control equipment operating. If emissions occur for less than 1 hr, then record emissions per batch in minutes (e.g. 5 lb VOC/20 minute batch).
- 6 Indicate method used to determine emission rate as follows:
MB = material balance; ST = stack test (give date of test);
EE = engineering estimate; O = other (specify).
- 7 Provide for all pollutant emissions. Typically, the units of parts per million by volume (ppmv) are used. If the emission is a mineral acid (sulfuric, nitric, hydrochloric or phosphoric) use units of milligram per dry cubic meter (mg/m³) at standard conditions (68 °F and 29.92 inches Hg) (see 45CSR7). If the pollutant is SO₂, use units of ppmv (See 45CSR10).

Attachment J
EMISSION POINTS DATA SUMMARY SHEET - Continued

Table 2: Release Parameter Data									
Emission Point ID No. <i>(Must match Emission Units Table)</i>	Source ID	Inner Diameter (ft.)	Exit Gas			Emission Point Elevation (ft)		UTM Coordinates (km)	
			Temp. (oF)	Volumetric Flow ¹ (acfm) <i>(At operating conditions)</i>	Velocity (fps)	Ground Level <i>(Height above mean sea level)</i>	Stack Height ² <i>(Height of emissions above ground level)</i>	Northing	Easting
EPCE-1	CE-01	1.0	1,024	9,227	195.8	1,210 ft	20 ft	4,436.030	536.535
EPCE-2	CE-02	1.0	1,024	9,227	195.8	1,210 ft	20 ft	4,436.030	536.535
EPCE-3	CE-03	1.0	1,024	9,227	195.8	1,210 ft	20 ft	4,436.030	536.535
EPCE-4	CE-04	1.0	1,024	9,227	195.8	1,210 ft	20 ft	4,436.030	536.535
EPCE-5	CE-05	1.0	1,024	9,227	195.8	1,210 ft	20 ft	4,436.030	536.535
EPCE-6	CE-06	1.0	1,024	9,227	195.8	1,210 ft	20 ft	4,436.030	536.535
EPCE-7	CE-07	1.0	1,024	9,227	195.8	1,210 ft	20 ft	4,436.030	536.535
EPCE-8	CE-08	1.0	1,024	9,227	195.8	1,210 ft	20 ft	4,436.030	536.535
EPCE-9	CE-09	1.0	1,024	9,227	195.8	1,210 ft	20 ft	4,436.030	536.535
EPCE-10	CE-10	1.0	1,024	9,227	195.8	1,210 ft	20 ft	4,436.030	536.535
EPCE-11	CE-11	1.0	1,024	9,227	195.8	1,210 ft	20 ft	4,436.030	536.535
EPCE-12	CE-12	1.0	1,024	9,227	195.8	1,210 ft	20 ft	4,436.030	536.535
EPCRP	CRP	0.8	1,382	2,995	---	1,210 ft	8 ft	4,436.030	536.535
EPGEN-2	GEN	2.0	110	---	---	1,210 ft	20 ft	4,436.030	536.535
EPSTL-1	DHY-01	2.0	110	---	---	1,210 ft	20 ft	4,436.030	536.535
EPSTL-2	DHY-02	---	212	---	---	1,210 ft	---	4,436.030	536.535
EPSTL-3	DHY-03	---	212	---	---	1,210 ft	---	4,436.030	536.535
EPRBL-1	BLR-01	---	212	---	---	1,210 ft	---	4,436.030	536.535
EPRBL-2	BLR-02	1.3	400	---	---	1,210 ft	---	4,436.030	536.535
EPRBL-3	BLR-03	1.3	400	---	---	1,210 ft	---	4,436.030	536.535
EPHT-1	HTR-01	1.3	400	---	---	1,210 ft	---	4,436.030	536.535
EPHT-2	HTR-02	0.7	450	---	---	1,210 ft	---	4,436.030	536.535
EPTK-1	TK-01	0.7	450	---	---	1,210 ft	---	4,436.030	536.535
EPTK-2	TK-02	---	Ambient	---	---	1,210 ft	---	4,436.030	536.535
EPTK-3	TK-03	---	Ambient	---	---	1,210 ft	---	4,436.030	536.535
EPTK-4	TK-04	---	Ambient	---	---	1,210 ft	---	4,436.030	536.535
EPTK-5	TK-05	---	Ambient	---	---	1,210 ft	---	4,436.030	536.535
EPTK-6	TK-06	---	Ambient	---	---	1,210 ft	---	4,436.030	536.535
EPTK-7	TK-07	---	Ambient	---	---	1,210 ft	---	4,436.030	536.535
EPTK-8	TK-08	---	Ambient	---	---	1,210 ft	---	4,436.030	536.535
EPWTK-9	WTK-01	---	Ambient	---	---	1,210 ft	---	4,436.030	536.535
EPWTK-10	WTK-02	0.3	Ambient	---	---	1,210 ft	20 ft	4,436.030	536.535
EPLOAD-1	TLO	0.3	Ambient	---	---	1,210 ft	20 ft	4,436.030	536.535
EPLOAD-2	WTLO	---	Ambient	---	---	1,210 ft	---	4,436.030	536.535
EPBD	CBD/ESD	0.4	Ambient	---	---	1,210 ft	8 ft	4,436.030	536.535
EPPIG	PIG	2.0	110	---	---	1,210 ft	20 ft	4,436.030	536.535

¹ Give at operating conditions. Include inerts.
² Release height of emissions above ground level.

Attachment K

Fugitive Emissions Data Summary Sheet

“27. Fill out the **Fugitive Emissions Data Summary Sheet** and provide it as Attachment K.”

- **Application Forms Checklist**
 - **Fugitive Emissions Data Summary Sheet**
-

Appalachia Midstream Services, LLC (AMS)
Battle Run Compressor Station (BRCS)
 Application for 45CSR13 New Source Review Permit Modification (NSR)
Attachment K - Fugitive Emissions

Fugitive Emissions Data Summary Sheet

The FUGITIVE EMISSIONS SUMMARY SHEET provides a summation of fugitive emissions. Fugitive emissions are those emissions which could not reasonably pass through a stack, chimney, vent or other functionally equivalent opening. Note that uncaptured process emissions are not considered to be fugitive, and must be accounted for on the appropriate EMISSIONS UNIT DATA SHEET and on the EMISSION POINTS DATA SUMMARY SHEET.

Please note that total emissions from the source are equal to all vented emissions, all fugitive emissions, plus all other emissions (e.g. uncaptured emissions).

APPLICATION FORMS CHECKLIST - FUGITIVE EMISSIONS

1.) Will there be haul road activities? <input type="checkbox"/> Yes <input checked="" type="checkbox"/> No <input type="checkbox"/> If Yes, then complete the HAUL ROAD EMISSIONS UNIT DATA SHEET.
2.) Will there be Storage Piles? <input type="checkbox"/> Yes <input checked="" type="checkbox"/> No <input type="checkbox"/> If Yes, then complete Table 1 of the NONMETALLIC MINERALS PROCESSING EMISSIONS UNIT DATA SHEET.
3.) Will there be Liquid Loading/Unloading Operations? <input checked="" type="checkbox"/> Yes <input type="checkbox"/> No ((Truck Load-Out (TLO and WTLO) are include in the Point Source Emissions)) <input checked="" type="checkbox"/> If Yes, then complete the BULK LIQUID TRANSFER OPERATIONS EMISSIONS UNIT DATA SHEET.
4.) Will there be emissions of air pollutants from Wastewater Treatment Evaporation? <input type="checkbox"/> Yes <input checked="" type="checkbox"/> No <input type="checkbox"/> If Yes, then complete the GENERAL EMISSIONS UNIT DATA SHEET.
5.) Will there be Equipment Leaks (e.g. leaks from pumps, compressors, in-line process valves, pressure relief devices, open-ended valves, sampling connections, flanges, agitators, cooling towers, etc.)? <input checked="" type="checkbox"/> Yes <input type="checkbox"/> No <input checked="" type="checkbox"/> If Yes, then complete the LEAK SOURCE DATA SHEET section of the CHEMICAL PROCESSES EMISSIONS DATA SHEET.
6.) Will there be General Clean-up VOC Operations? <input type="checkbox"/> Yes <input checked="" type="checkbox"/> No <input type="checkbox"/> If Yes, then complete the GENERAL EMISSIONS UNIT DATA SHEET.
7.) Will there be any other activities that generate fugitive emissions? <input type="checkbox"/> Yes <input checked="" type="checkbox"/> No <input type="checkbox"/> If Yes, then complete the GENERAL EMISSIONS UNIT DATA SHEET or the most appropriate form. If you answered "NO" to all of the items above, it is not necessary to complete the following table, "Fugitive Emissions Summary."

Battle Run Compressor Station (BRCS)

Application for 45CSR13 New Source Review Permit Modification (NSR)

Attachment K - Fugitive Emissions**Fugitive Emissions Data Summary Sheet - Continued**

The FUGITIVE EMISSIONS SUMMARY SHEET provides a summation of fugitive emissions. Fugitive emissions are those emissions which could not reasonably pass through a stack, chimney, vent or other functionally equivalent opening. Note that uncaptured process emissions are not considered to be fugitive, and must be accounted for on the appropriate EMISSIONS UNIT DATA SHEET and on the EMISSION POINTS DATA SUMMARY SHEET.

Please note that total emissions from the source are equal to all vented emissions, all fugitive emissions, plus all other emissions.

FUGITIVE EMISSIONS SUMMARY	All Regulated Pollutants Chemical Name/CAS ¹	Maximum Potential Pre-Controlled Emissions ²		Maximum Potential Controlled Emissions ³		Est. Method Used ⁴
		lb/hr	ton/yr	lb/hr	ton/yr	
Paved Haul Roads	na	---	---	---	---	---
Unpaved Haul Roads	na	---	---	---	---	---
Storage Pile Emissions	na	---	---	---	---	---
Loading/Unloading Operations	((Truck Load-Out (TLO and WTLO) are include in the Point Source Emissions))					
Wastewater Treatment	na	---	---	---	---	---
Process and Piping Fugitives (FUG-G, FUG-O) Engine Crankcase (ECC) (Total Combined)	NOX	0.05	0.21	0.05	0.21	Vendor
	CO	0.29	1.28	0.29	1.28	Vendor
	VOC	12.53	54.88	12.53	54.88	Varies
	PM10/2.5	3E-03	0.02	3E-03	0.02	Vendor
	SO2	2E-04	9E-04	2E-04	9E-04	Vendor
	Total HAPs	0.44	1.94	0.44	1.94	Sum
	Carbon Dioxide Equivalent (CO2e)	317	1,389	317	1,389	Sum
General Clean-up VOC Emissions	na	---	---	---	---	---
Other	na	---	---	---	---	---

¹ List all regulated air pollutants. Speciate VOCs, including all HAPs. Follow chemical name with Chemical Abstracts Service (CAS) number. LIST Acids, CO, CS₂, VOCs, H₂S, Inorganics, Lead, Organics, O₃, NO, NO₂, SO₂, SO₃, all applicable Greenhouse Gases, etc. DO NOT LIST H₂, H₂O, N₂, O₂, and Noble Gases.

² Give rate with no control equipment operating. If emissions occur for less than 1 hr, then record emissions per batch in min (e.g. 5 lb VOC/20 min batch).

³ Give rate with proposed control equipment operating. If emissions occur for less than 1 hr, then record emissions per batch in min (e.g. 5 lb VOC/20 min batch).

⁴ Indicate method used to determine emission rate as follows:

MB = material balance; ST = stack test (give date of test); EE = engineering estimate; O = other (specify).

Attachment L

Emissions Unit Data Sheet(s)

“28. Fill out the **Emissions Unit Data Sheet(s)** as Attachment L.”

- **Natural Gas-Fired Compressor/Generator Engine Data Sheet**
 - 1,380 bhp CAT G3516B Generator Engines (CE-01 thru CE-12)
 - 605 bhp Baldor IGLC420-2N Generator Engine (GEN)

 - **Natural Gas Glycol Dehydrator Unit Data Sheet**
 - 55.0 MMscfd Dehydrators (DHY-01 thru DHY-03)
 - 1.00 MMBtu/hr Reboilers (BLR-01 thru BLR-03)
 - 40 CFR Part 63; Subpart HH & HHH Registration Form

 - **Gas-Fired Boiler/Line Heater Data Sheet**
 - 0.50 MMBtu/hr Heater Treaters (HTR-01 and HTR-02)

 - **Storage Tank Data Sheet**
 - Stabilized Condensate (SC) Storage Tanks (TK-01 thru TK-08)
 - Produced Water (PW) Storage Tanks (WTK-01 and WTK-02)

 - **Bulk Liquid Transfer Operations Data Sheet**
 - Stabilized Condensate (SC) Truck Load-Out (TLO)
 - Produced Water (PW) Truck Load-Out (WTLO)

 - **Leak Source Data Sheet**
-

Battle Run Compressor Station (BRCS)

Application for 45CSR13 New Source Review Permit Modification (NSR)

Attachment L - Emission Unit Data Sheet**Natural Gas-Fired Compressor/Generator Engine Data Sheet**

Description		Compressor Engines		Generator Engine	
Source Identification Number ¹		CE-01 thru CE-12 (Each)		GEN	
Engine Manufacturer and Model		CAT G3516B		Baldor IGLC420-2N	
Manufacturer's Rated bhp/rpm		1,380 / 1,400		605 / 1,800	
Source Status ²		MS		MS	
Date Installed/Modified/Removed ³		2012 / 2018 / na		2012 / 2018 / na	
Manufactured/Reconstruction Date ⁴		2012 / 2018 / na		2012 / 2018 / na	
Certified Engine (40CFR60 NSPS JJJJ) ⁵		No		No	
Engine, Fuel and Combustion Data	Engine Type ⁶	4SLB		4SRB	
	APCD Type ⁷	OxCat		NSCR	
	Fuel Type ⁸	RG		RG	
	H ₂ S (gr/100 scf)	0.2		0.2	
	Operating bhp/rpm	1,380 / 1,400		605 / 1,800	
	BSFC (Btu/bhp-hr)	8,138		7,488	
	Fuel (ft ³ /hr)	11,010		4,441	
	Fuel (MMft ³ /yr)	96.45		38.91	
	Operation (hrs/yr)	8,760		8,760	
Reference ⁹	PTE ¹⁰	lbs/hr	tons/yr	lbs/hr	tons/yr
MD/AP	NOX	1.52	6.66	1.33	5.84
MD/AP	CO	1.41	6.20	2.67	11.68
MD/AP	NMNEHC	0.63	2.77	0.93	4.09
MD/AP	VOC	0.77	3.38	1.05	4.60
AP	PM10/2.5	0.11	0.49	0.09	0.39
AP	SO2	0.01	0.03	0.00	0.01
AP	Acetaldehyde	0.02	0.08	0.01	0.06
AP	Acrolein	0.01	0.05	0.01	0.05
AP	Benzene	1E-03	4E-03	0.01	0.03
AP	Butadiene, 1,3-	6E-04	3E-03	3E-03	0.01
AP	Ethylbenzene	9E-05	4E-04	1E-04	5E-04
MD/AP	Formaldehyde	0.11	0.48	0.12	0.51
AP	n-Hexane	2E-03	0.01	---	---
AP	Methanol (MeOH)	0.01	0.02	0.01	0.06
AP	POM	8E-04	3E-03	4E-04	2E-03
AP	Toluene	9E-04	4E-03	3E-03	0.01
AP	2,2,4-TMP (i-Octane)	6E-04	3E-03	---	---
AP	Xylenes	4E-04	2E-03	9E-04	4E-03
AP	Other/Trace HAP	7E-04	3E-03	8E-04	4E-03
SUM	Total HAP	0.15	0.67	0.17	0.75
MD/AP	CO2	1,603	7,023	498	2,183
MD/40CFR98	CH4	14	61	1.04	4.56
MD/40CFR98	N2O	2E-03	0.01	1E-03	4E-03
WGT SUM	CO2e	1,955	8,563	525	2,298

Appalachia Midstream Services, LLC (AMS)
Battle Run Compressor Station (BRCS)
 Application for 45CSR13 New Source Review Permit Modification (NSR)
Attachment L - Emission Unit Data Sheet

Natural Gas-Fired Compressor/Generator Engine Data Sheet

Proposed Permit Modifications

<i>Emission Unit Description</i>	CE-01 thru CE-12 (each)															
Proposed Modifications to WVDEP-DAQ Permit R13-2916A are shown below:																
5.1.1.	To demonstrate compliance with Section 5.1.2, the quantity of natural gas that shall be consumed in each of the twelve (12) 1,380 hp natural gas fired reciprocating engines, Caterpillar G3516B (EPCE-1 - EPCE-12) shall not exceed 9,233 11,010 scf/hr and 80.88 96.45 x 10 ⁶ scf/yr for each engine.															
5.1.2.	Maximum emissions from each of the twelve (12) 1,380 hp natural gas fired reciprocating engines, Caterpillar G3516B (EPCE-1 - EPCE-12) shall not exceed the following limits:															
	<table border="1" style="margin-left: auto; margin-right: auto; border-collapse: collapse;"> <thead> <tr> <th style="text-align: center;">Pollutant</th> <th style="text-align: center;">Maximum lb/hr</th> <th style="text-align: center;">Maximum ton/yr</th> </tr> </thead> <tbody> <tr> <td style="text-align: center;">Nitrogen Oxides</td> <td style="text-align: center;">1.52</td> <td style="text-align: center;">6.66</td> </tr> <tr> <td style="text-align: center;">Carbon Monoxide</td> <td style="text-align: center;">0.19 1.41</td> <td style="text-align: center;">0.83 6.20</td> </tr> <tr> <td style="text-align: center;">Volatile Organic Compounds</td> <td style="text-align: center;">0.63 0.77</td> <td style="text-align: center;">2.77 3.38</td> </tr> <tr> <td style="text-align: center;">Formaldehyde</td> <td style="text-align: center;">0.06 0.11</td> <td style="text-align: center;">0.27 0.48</td> </tr> </tbody> </table>	Pollutant	Maximum lb/hr	Maximum ton/yr	Nitrogen Oxides	1.52	6.66	Carbon Monoxide	0.19 1.41	0.83 6.20	Volatile Organic Compounds	0.63 0.77	2.77 3.38	Formaldehyde	0.06 0.11	0.27 0.48
Pollutant	Maximum lb/hr	Maximum ton/yr														
Nitrogen Oxides	1.52	6.66														
Carbon Monoxide	0.19 1.41	0.83 6.20														
Volatile Organic Compounds	0.63 0.77	2.77 3.38														
Formaldehyde	0.06 0.11	0.27 0.48														

<i>Emission Unit Description</i>	GEN																		
Proposed Modifications to WVDEP-DAQ Permit R13-2916A are shown below:																			
6.1.1.	To demonstrate compliance with Section 6.1.2, the quantity of natural gas that shall be consumed in 605 hp natural gas-fired Baldor generator (EPGEN-2) shall not exceed 4,230 4,441 scf/hr and 37.06 38.91 x 10 ⁶ scf/yr.																		
6.1.2.	Maximum emissions from the 605 hp natural gas-fired Baldor generator (EPGEN-2) shall not exceed the following limits:																		
	<table border="1" style="margin-left: auto; margin-right: auto; border-collapse: collapse;"> <thead> <tr> <th style="text-align: center;">Pollutant</th> <th style="text-align: center;">Maximum lb/hr</th> <th style="text-align: center;">Maximum ton/yr</th> </tr> </thead> <tbody> <tr> <td style="text-align: center;">Nitrogen Oxides</td> <td style="text-align: center;">1.33</td> <td style="text-align: center;">5.84</td> </tr> <tr> <td style="text-align: center;">Carbon Monoxide</td> <td style="text-align: center;">2.67</td> <td style="text-align: center;">11.68</td> </tr> <tr> <td style="text-align: center;">Particulate Matter (PM10)</td> <td style="text-align: center;">0.11 0.09</td> <td style="text-align: center;">0.48 0.39</td> </tr> <tr> <td style="text-align: center;">Volatile Organic Compounds</td> <td style="text-align: center;">0.93 1.05</td> <td style="text-align: center;">4.09 4.60</td> </tr> <tr> <td style="text-align: center;">Formaldehyde</td> <td style="text-align: center;">0.12</td> <td style="text-align: center;">0.51</td> </tr> </tbody> </table>	Pollutant	Maximum lb/hr	Maximum ton/yr	Nitrogen Oxides	1.33	5.84	Carbon Monoxide	2.67	11.68	Particulate Matter (PM10)	0.11 0.09	0.48 0.39	Volatile Organic Compounds	0.93 1.05	4.09 4.60	Formaldehyde	0.12	0.51
Pollutant	Maximum lb/hr	Maximum ton/yr																	
Nitrogen Oxides	1.33	5.84																	
Carbon Monoxide	2.67	11.68																	
Particulate Matter (PM10)	0.11 0.09	0.48 0.39																	
Volatile Organic Compounds	0.93 1.05	4.09 4.60																	
Formaldehyde	0.12	0.51																	

Appalachia Midstream Services, LLC (AMS)
Battle Run Compressor Station (BRCS)
Application for 45CSR13 New Source Review Permit Modification (NSR)
Attachment L - Emission Unit Data Sheet

Notes to Natural Gas-Fired Compressor/Generator Engine Data Sheet

1. Enter the appropriate Source Identification Number for each natural gas-fueled reciprocating internal combustion compressor/generator engine located at the compressor station. Multiple compressor engines should be designated CE-1, CE-2, CE-3 etc. Generator engines should be designated GE-1, GE-2, GE-3 etc. If more than three (3) engines exist, please use additional sheets.
2. Enter the Source Status using the following codes:
NS = Construction of New Source (installation)
ES = Existing Source
MS = Modification of Existing Source
RS = Removal of Source
3. Enter the date (or anticipated date) of the engine's installation (construction of source), modification or removal.
4. Enter the date that the engine was manufactured, modified or reconstructed.
5. Is the engine a certified stationary spark ignition internal combustion engine according to 40CFR60 Subpart JJJJ. If so, the engine and control device must be operated and maintained in accordance with the manufacturer's emission-related written instructions. You must keep records of conducted maintenance to demonstrate compliance, but no performance testing is required. If the certified engine is not operated and maintained in accordance with the manufacturer's emission-related written instructions, the engine will be considered a non-certified engine and you must demonstrate compliance according to 40CFR§60.4243a(2)(i) through (iii), as appropriate.

Provide a manufacturer's data sheet for all engines being registered.
6. Enter the Engine Type designation(s) using the following codes:
LB2S = Lean Burn Two Stroke
RB4S = Rich Burn Four Stroke
LB4S = Lean Burn Four Stroke
7. Enter the Air Pollution Control Device (APCD) type designation(s) using the following codes:
A/F = Air/Fuel Ratio
IR = Ignition Retard
HEIS = High Energy Ignition System
SIPC = Screw-in Precombustion Chambers
PSC = Prestratified Charge
LEC = Low Emission Combustion
NSCR = Non-Selective Catalytic Reduction
SCR = Lean Burn & Selective Catalytic Reduction
8. Enter the Fuel Type using the following codes:
PQ = Pipeline Quality Natural Gas
RG = Raw Natural Gas
9. Enter the Potential Emissions Data Reference designation using the following codes. Attach all referenced data to this Compressor/Generator Data Sheet(s).
MD = Manufacturer's Data
AP = AP-42
GR = GRI-HAPCalcTM
OT = Other (please list) _____
10. Enter each engine's Potential to Emit (PTE) for the listed regulated pollutants in pounds per hour and tons per year. PTE shall be calculated at manufacturer's rated brake horsepower and may reflect reduction efficiencies of listed Air Pollution Control Devices. Emergency generator engines may use 500 hours of operation when calculating PTE. PTE data from this data sheet shall be incorporated in the Emissions Summary Sheet.

Battle Run Compressor Station (BRCS)

Application for 45CSR13 New Source Review Permit Modification (NSR)

Attachment L - Emission Unit Data Sheet**Natural Gas Glycol Dehydration Unit Data Sheet**

General Glycol Dehydration Unit Data		Company ID		DHY-01 thru -03			
		Manufacturer and Model		---			
		Max Dry Gas Flow Rate (MMscfd)		55.0			
		Heat Input (MMBtu/hr) - HHV		1.00			
		Design Type (DEG or TEG)		TEG			
		Source Status ²		MS			
		Date Installed/Modified/Removed ³		2012 / 2018 / na			
		Regenerator Still Vent APCD ⁴		CC			
		Fuel HV (Btu/scf) - HHV		1,020			
		H ₂ S Content (gr/100 scf)		0.20			
		Operation (hrs/yr)		8,760			
Source ID # ¹	Vent	Reference ⁵	PTE ⁶	lbs/hr	tons/yr		
DHY-01 DHY-02 DHY-03 (Each)	Dehydrator 01 thru 03 Regenerator Still Vent (Flash Tank Off-Gas is 100% Recycle/Recalim)	GRI-GLYCalc	VOC	1.89	8.29		
		GRI-GLYCalc	Benzene	0.07	0.29		
		GRI-GLYCalc	E-Benzene	5E-03	0.02		
		GRI-GLYCalc	n-Hexane	0.10	0.43		
		GRI-GLYCalc	Toluene	0.09	0.41		
		GRI-GLYCalc	2,2,4-TMP	2E-03	0.01		
		GRI-GLYCalc	Xylenes	0.04	0.17		
		GRI-GLYCalc	Total HAP	0.30	1.34		
		GRI-GLYCalc	CO ₂ e	2.74	12.00		
BLR-01 BLR-02 BLR-03 (Each)	Reboiler 01 thru 03 (Each)	AP-42	NOX	0.10	0.43		
		AP-42	CO	0.08	0.36		
		AP-42	VOC	0.01	0.02		
		AP-42	PM _{10/2.5}	0.01	0.03		
		AP-42	SO ₂	6E-04	3E-03		
		AP-42	Acetaldehyde	---	---		
		AP-42	Acrolein	---	---		
		AP-42	Benzene	2E-06	9E-06		
		AP-42	Butadiene, 1,3-	---	---		
		AP-42	Ethylbenzene	---	---		
		AP-42	Formaldehyde	7E-05	3E-04		
		AP-42	n-Hexane	2E-03	0.01		
		AP-42	Methanol	---	---		
		AP-42	POM	7E-07	3E-06		
		AP-42	Toluene	3E-06	1E-05		
		AP-42	TMP, 2,2,4-	---	---		
		AP-42	Xylenes	---	---		
		AP-42	Other HAP	1E-06	5E-06		
		AP-42	Total HAP	2E-03	0.01		
		AP-42	CO ₂	118	515		
AP-42	CH ₄	2E-03	0.01				
AP-42	N ₂ O	2E-03	0.01				
40CFR98	CO ₂ e	118	518				

Appalachia Midstream Services, LLC (AMS)
Battle Run Compressor Station (BRCS)
 Application for 45CSR13 New Source Review Permit Modification (NSR)
Attachment L - Emission Unit Data Sheet
Natural Gas Glycol Dehydration Unit Data Sheet

Proposed Permit Modifications

<i>Emission Unit Description</i>	DHY-01 thru DHY-03									
Proposed Modifications to WVDEP-DAQ Permit R13-2916A are shown below:										
7.1.5. Maximum emissions from each of the Glycol Regenerator Still Columns (EUDHY-1, EUDHY-2, EUDHY-3) shall not exceed the following limits:										
<table border="1" style="margin-left: auto; margin-right: auto; border-collapse: collapse;"> <thead> <tr> <th style="text-align: center;">Pollutant</th> <th style="text-align: center;">Maximum lb/hr</th> <th style="text-align: center;">Maximum ton/yr</th> </tr> </thead> <tbody> <tr> <td style="text-align: center;">Volatile Organic Compounds</td> <td style="text-align: center;">0.32 1.89</td> <td style="text-align: center;">1.39 8.29</td> </tr> <tr> <td style="text-align: center;">Total HAPs</td> <td style="text-align: center;">0.01 0.30</td> <td style="text-align: center;">0.05 1.34</td> </tr> </tbody> </table>	Pollutant	Maximum lb/hr	Maximum ton/yr	Volatile Organic Compounds	0.32 1.89	1.39 8.29	Total HAPs	0.01 0.30	0.05 1.34	
Pollutant	Maximum lb/hr	Maximum ton/yr								
Volatile Organic Compounds	0.32 1.89	1.39 8.29								
Total HAPs	0.01 0.30	0.05 1.34								

<i>Emission Unit Description</i>	BLR-01 thru BLR-03												
Proposed Modifications to WVDEP-DAQ Permit R13-2916A are shown below:													
7.1.3. To demonstrate compliance with Section 7.1.4, the quantity of natural gas that shall be consumed in each of the 1.0 MMBtu/hr Glycol Reboilers (EURBL-1, EURBL-2, EURBL-3) shall not exceed 750 980 scf/hr and 6.55 8.59 x 10 ⁶ scf/yr for each reboiler.													
7.1.4. Maximum emissions from each of the Glycol Reboilers (EURBL-1, EURBL-2, EURBL-3) shall not exceed the following limits:													
<table border="1" style="margin-left: auto; margin-right: auto; border-collapse: collapse;"> <thead> <tr> <th style="text-align: center;">Pollutant</th> <th style="text-align: center;">Maximum lb/hr</th> <th style="text-align: center;">Maximum ton/yr</th> </tr> </thead> <tbody> <tr> <td style="text-align: center;">Nitrogen Oxides</td> <td style="text-align: center;">0.07 0.10</td> <td style="text-align: center;">0.33 0.43</td> </tr> <tr> <td style="text-align: center;">Carbon Monoxide</td> <td style="text-align: center;">0.06 0.08</td> <td style="text-align: center;">0.28 0.36</td> </tr> <tr> <td style="text-align: center;">Volatile Organic Compounds</td> <td style="text-align: center;">0.01</td> <td style="text-align: center;">0.02</td> </tr> </tbody> </table>	Pollutant	Maximum lb/hr	Maximum ton/yr	Nitrogen Oxides	0.07 0.10	0.33 0.43	Carbon Monoxide	0.06 0.08	0.28 0.36	Volatile Organic Compounds	0.01	0.02	
Pollutant	Maximum lb/hr	Maximum ton/yr											
Nitrogen Oxides	0.07 0.10	0.33 0.43											
Carbon Monoxide	0.06 0.08	0.28 0.36											
Volatile Organic Compounds	0.01	0.02											

Battle Run Compressor Station (BRCS)

Application for 45CSR13 New Source Review Permit Modification (NSR)

Attachment L - Emission Unit Data Sheet

Notes to Natural Gas Glycol Dehydration Unit Data Sheet

1. Enter the appropriate Source Identification Numbers for the glycol dehydration unit Reboiler Vent and glycol Regenerator Still Vent. The glycol dehydration unit Reboiler Vent and glycol Regenerator Still Vent should be designated RBV-1 and RSV-1, respectively. If the compressor station incorporates multiple glycol dehydration units, a Glycol Dehydration Unit Data Sheet shall be completed for each, using Source Identification #s RBV-2 and RSV-2, RBV-3 and RSV-3, etc.

2. Enter the Source Status using the following codes:

- NS = Construction of New Source
- ES = Existing Source
- MS = Modification of Existing Source
- RS = Removal of Source

3. Enter the date (or anticipated date) of the glycol dehydration unit's installation (construction of source), modification or removal.

4. Enter the Air Pollution Control Device (APCD) type designation using the following codes:

- NA = None
- CD = Condenser
- FL = Flare
- CC = Condenser/Combustion Combination
- TO = Thermal Oxidizer

5. Enter the Potential Emissions Data Reference designation using the following codes:

- MD = Manufacturer's Data
- AP = AP-42
- GR = GRI-GLYCalcTM
- OT = Other (please list): _____

6. Enter the Reboiler Vent and glycol Regenerator Still Vent Potential to Emit (PTE) for the listed regulated pollutants in lbs per hour and tons per year. The glycol Regenerator Still Vent potential emissions may be determined using the most recent version of the thermodynamic software model GRI-GLYCalcTM (Radian International LLC & Gas Research Institute). Attach all referenced Potential Emissions Data (or calculations) and the GRI-GLYCalc Aggregate Calculations Report to this Glycol Dehydration Unit Data Sheet(s). This PTE data shall be incorporated in the Emissions Summary Sheet.

Include a copy of the GRI-GLYCalcTM analysis. This includes a printout of the aggregate calculations report, which shall include emissions reports, equipment reports, and stream reports.

***An explanation of input parameters and examples, when using GRI-GLYCalcTM is available on our website.**

Appalachia Midstream Services, LLC (AMS)
Battle Run Compressor Station (BRCS)
 Application for 45CSR13 New Source Review Permit Modification (NSR)
Attachment L - Emission Unit Data Sheet

40 CFR Part 63; Subpart HH & HHH Registration Form

West Virginia Department of Environmental Protection
 Division of Air Quality
 40 CFR Part 63; Subpart HH & HHH Registration Form

DIVISION OF AIR QUALITY : (304) 926-0475
 WEB PAGE: <http://www.wvdep.org>

Complete this form for any oil and natural gas production or natural gas transmission and storage facility that uses an affected unit under HH/HHH, whether subject or not.

Section A: Facility Description	
Affected facility actual annual average natural gas throughput (scf/day):	55.0 MM (Each)
Affected facility actual annual average hydrocarbon liquid throughput: (bbl/day):	na
The affected facility processes, upgrades, or stores hydrocarbon liquids prior to custody transfer.	<input checked="" type="checkbox"/> Yes <input type="checkbox"/> No
The affected facility processes, upgrades, or stores natural gas prior to the point at which natural gas (NG) enters the NG transmission and storage source category or is delivered to the end user.	<input checked="" type="checkbox"/> Yes <input type="checkbox"/> No
The affected facility is:	<input checked="" type="checkbox"/> prior to a NG processing plant <input type="checkbox"/> NG processing plant <input type="checkbox"/> prior to the point of custody transfer and there is no NG processing plant
The affected facility transports or stores natural gas prior to entering the pipeline to a local distribution company or to a final end user (if there is no local distribution company).	<input type="checkbox"/> Yes <input checked="" type="checkbox"/> No
The affected facility exclusively processes, stores, or transfers black oil with an initial producing gas-to-oil ratio (GOR): na scf/bbl API gravity: na degrees	<input type="checkbox"/> Yes <input checked="" type="checkbox"/> No

Section B: Dehydration Unit (if applicable)¹	
Description: 55.0 MMscfd - Dehydrator 01 thru 03 (Each)	
Date of Installation: 2012	Annual Operating Hours: 8,760 Burner rating (MMbtu/hr): 1.00
Exhaust Stack Height (ft): 10.0	Stack Diameter (ft): 0.6 Stack Temp. (oF): 120
Glycol Type: <input checked="" type="checkbox"/> TEG <input type="checkbox"/> EG <input type="checkbox"/> Other: na	
Glycol Pump Type: <input checked="" type="checkbox"/> Elect <input type="checkbox"/> Gas If Gas, what is the volume ratio?: na	
Condenser installed? <input checked="" type="checkbox"/> Yes <input type="checkbox"/> No Exit Temp: 120 oF Condenser Pressure: 14.08 psia	
Incinerator/flare installed? <input type="checkbox"/> Yes <input checked="" type="checkbox"/> No Destruction Eff.: na	
Other controls installed? <input checked="" type="checkbox"/> Yes <input type="checkbox"/> No Describe: Condenser Off Gas used as fuel w/ 95% Control	
Wet Gas ² : (Upstream of Contact Tower)	Gas Temperature: 95 oF Gas Pressure: 1,100 psig Saturated Gas?: <input checked="" type="checkbox"/> Yes <input type="checkbox"/> No If no, water content?: na
Dry Gas: (Downstream of Contact Tower)	Gas Flowrate: Actual: 55.0 MMscfd Design: 55.0 MMscfd Water Content: 7.0 lb/MMscf
Lean Glycol:	Circulation Rate: Actual ³ : 22.0 gpm Max ⁴ : 22.0 gpm Pump make/model: Electric
Glycol Flash Tank (if applicable):	Temp: 120 oF Pressure: 50 psig Vented: <input type="checkbox"/> Yes <input checked="" type="checkbox"/> No If no, describe vapor control: 100% Flash Tank Off-Gas Recycle or Reclaim
Stripping Gas (if applicable):	Source of Gas na Rate: na

Appalachia Midstream Services, LLC (AMS)
Battle Run Compressor Station (BRCS)
 Application for 45CSR13 New Source Review Permit Modification (NSR)
Attachment L - Emission Unit Data Sheet

40 CFR Part 63; Subpart HH & HHH Registration Form - Continued

Please attach the following required dehydration unit information:

1. System map indicating the chain of custody information. See Page 43 of this document for an example of a gas flow schematic. It is not intended that the applicant provide this level of detail for all sources. The level of detail that is necessary is to establish where the custody transfer points are located. This can be accomplished by submitting a process flow diagram indicating custody transfer points and the natural gas flow. However, the DAQ reserves the right to request more detailed information in order to make the necessary decisions.
2. Extended gas analysis from the Wet Gas Stream, including mole percent of C1-C8, benzene, ethylbenzene, toluene, xylene and n-hexane, using Gas Processors Association (GPA) 2286 (or similar). A sample should be taken from the inlet gas line, downstream from any inlet separator, and using a manifold to remove entrained liquids from the sample and a probe to collect the sample from the center of the gas line. GPA standard 2166 reference method or a modified version of EPA Method TO-14, (or similar) should be used.
3. GRI-GLYCalc Ver. 3.0 aggregate report based on maximum Lean Glycol circulation rate and maximum throughput.
4. Detailed calculations of gas or hydrocarbon flow rate.

Section C: Facility NESHAPS Subpart HH/HHH status

Subject to Subpart HH -- However, *EXEMPT* because the facility is an area source of HAP emissions and the actual average emissions of benzene from the glycol dehydration unit process vent to the atmosphere is < 0.90 megagram per year (1.0 tpy); see 40CFR§63.764(e)(1)(ii).

Affected facility status:
(choose only one)

Subject to Subpart HHH

Not Subject
Because:

- < 10/25 TPY
- Affected facility exclusively handles black oil.
- Facility-wide actual annual average NG throughput is < 650 thousand scf/day and facility-wide actual annual average hydrocarbon liquid is < 250 bpd.
- No affected source is present.

Appalachia Midstream Services, LLC (AMS)
Battle Run Compressor Station (BRCS)
Application for 45CSR13 New Source Review Permit Modification (NSR)
Attachment L - Emission Unit Data Sheet

Natural Gas-Fired Boiler/Line Heater Data Sheet

Source ID	Status	Design Heat Input (MMBtu/hr)	Hours of Operation (hrs/yr)	Fuel Heating Value (Btu/scf)	
HTR-01	Existing	0.50 MMBtu/hr	8,760	1,020	
HTR-02	Existing	0.50 MMBtu/hr	8,760	1,020	

Notes to NATURAL GAS FIRED BOILER/LINE HEATER DATA SHEET

1. Enter the appropriate Source Identification Numbers (Source ID #) for each boiler or line heater located at the compressor station. Boilers should be designated BLR-1, BLR-2, BLR-3, etc. Heaters or Line Heaters should be designated HTR-1, HTR-2, HTR-3, etc. Enter glycol dehydration unit reboiler vent data on the Glycol Dehydration Unit Data Sheet.
2. Enter the Status for each boiler or line heater using the following:
EXIST = Existing Equipment NEW = Installation of New Equipment REM = Equipment Removed
3. Enter boiler or line heater design heat input in mmBtu/hr.
4. Enter the annual hours of operation in hours/year for each boiler or line heater. □
5. Enter the fuel heating value in Btu/standard cubic foot.

Appalachia Midstream Services, LLC (AMS)
Battle Run Compressor Station (BRCS)
 Application for 45CSR13 New Source Review Permit Modification (NSR)
Attachment L - Emission Unit Data Sheet

Natural Gas-Fired Boiler/Line Heater Data Sheet

Proposed Permit Modifications

<i>Emission Unit Description</i>	HTR-01 and HTR-02									
<p>Proposed Modifications to WVDEP-DAQ Permit R13-2916A are shown below:</p>										
<p>8.1.2. Maximum emissions from each of the 0.50 MMBTU/hr Heater-Treaters (EPHT-1, EPHT-2) shall not exceed the following limits:</p>										
<table border="1" style="margin-left: auto; margin-right: auto; border-collapse: collapse;"> <thead> <tr> <th style="width: 30%;">Pollutant</th> <th style="width: 30%;">Maximum lb/hr</th> <th style="width: 30%;">Maximum ton/yr</th> </tr> </thead> <tbody> <tr> <td style="text-align: center;">Nitrogen Oxides</td> <td style="text-align: center;">0.04 0.06</td> <td style="text-align: center;">0.16 0.21</td> </tr> <tr> <td style="text-align: center;">Carbon Monoxide</td> <td style="text-align: center;">0.03 0.05</td> <td style="text-align: center;">0.14 0.18</td> </tr> </tbody> </table>	Pollutant	Maximum lb/hr	Maximum ton/yr	Nitrogen Oxides	0.04 0.06	0.16 0.21	Carbon Monoxide	0.03 0.05	0.14 0.18	
Pollutant	Maximum lb/hr	Maximum ton/yr								
Nitrogen Oxides	0.04 0.06	0.16 0.21								
Carbon Monoxide	0.03 0.05	0.14 0.18								
<p>8.1.3. To demonstrate compliance with Section 8.1.2, the quantity of natural gas that shall be consumed in each of the 0.50 MMBTU/hr Heater-Treaters (EPHT-1, EPHT-2) shall not exceed 375 600 scf/hr and 3.27 4.29 x 10⁶ scf/yr.</p>										

Appalachia Midstream Services, LLC (AMS)
Battle Run Compressor Station (BRCS)
 Application for 45CSR13 New Source Review Permit Modification (NSR)
Attachment L - Emission Unit Data Sheet

Storage Tank Data Sheet

Source ID	Status	Contents	Volume (gal)	Diam (ft)	Thru-Put (gal/yr)	Orientation	Ave Liq Hght (ft)
TK-01	Existing	Stabilized Condensate (SC)	16,800	12.0	1.25 MM	Vert	10.0
TK-02	Existing	Stabilized Condensate (SC)	16,800	12.0	1.25 MM	Vert	10.0
TK-03	Existing	Stabilized Condensate (SC)	16,800	12.0	1.25 MM	Vert	10.0
TK-04	Existing	Stabilized Condensate (SC)	16,800	12.0	1.25 MM	Vert	10.0
TK-05	Existing	Stabilized Condensate (SC)	16,800	12.0	1.25 MM	Vert	10.0
TK-06	Existing	Stabilized Condensate (SC)	16,800	12.0	1.25 MM	Vert	10.0
TK-07	Existing	Stabilized Condensate (SC)	16,800	12.0	1.25 MM	Vert	10.0
TK-08	Existing	Stabilized Condensate (SC)	16,800	12.0	1.25 MM	Vert	10.0
WTK-01	Existing	Produced Water (PW)	16,800	12.0	0.77 MM	Vert	10.0
WTK-02	Existing	Produced Water (PW)	16,800	12.0	0.77 MM	Vert	10.0

Notes to STORAGE TANK DATA SHEET

1. Enter the appropriate Source Identification Numbers (Source ID #) for each storage tank located at the compressor station. Tanks should be designated T01, T02, T03, etc.
2. Enter storage tank Status using the following:
 EXIST Existing Equipment
 NEW Installation of New Equipment
 REM Equipment Removed
3. Enter storage tank content such as condensate, pipeline liquids, glycol (DEG or TEG), lube oil, etc.
4. Enter storage tank volume in gallons.
5. Enter storage tank diameter in feet.
6. Enter storage tank throughput in gallons per year.
7. Enter storage tank orientation using the following:
 VERT Vertical Tank
 HORZ Horizontal Tank
8. Enter storage tank average liquid height in feet.

Appalachia Midstream Services, LLC (AMS)
Battle Run Compressor Station (BRCS)
Application for 45CSR13 New Source Review Permit Modification (NSR)
Attachment L - Emission Unit Data Sheet
Storage Tank Data Sheet

Proposed Permit Modifications

<i>Emission Unit Description</i>	TK-01 thru TK-08, and WTK-01 and WTK-02
Proposed Modifications to WVDEP-DAQ Permit R13-2916A are shown below:	
9.1.1.	Emissions from the stabilized condensate storage tanks (EPTK-1 - EPTK-8, EPWTK-1, EPWTK-2) shall be controlled by a vapor recovery system. This vapor recovery system shall be designed to achieve a minimum guaranteed control efficiency of 98% 95% for volatile organic compound (VOC) emissions.
9.1.2.	The vapor recovery system must be installed and operating prior to start-up of the storage tanks (EPTK-1 - EPTK-8, EPWTK-1, EPWTK-2).

Battle Run Compressor Station (BRCS)

Application for 45CSR13 New Source Review Permit Modification (NSR)

Attachment L - Emission Unit Data Sheet**Bulk Liquid Transfer Operations**

Furnish the following information for each new or modified bulk liquid transfer area or loading rack, as shown on the Equipment List Form and other parts of this application. This form is to be used for bulk liquid transfer operations such as to and from drums, marine vessels, rail tank cars, and tank trucks

Identification Number (as assigned on Equipment List Form):		TLO / WTLO		
1. Loading Area Name:		Battle Run Compressor Station (BRCS)		
2. Type of cargo vessels accommodated at this rack or transfer point (check as many as apply):				
<input type="checkbox"/> Drums <input type="checkbox"/> Marine Vessels <input type="checkbox"/> Rail Tank Cars <input checked="" type="checkbox"/> Tank Trucks				
3. Loading Rack or Transfer Point Data:				
Number of Pumps		Two (2)		
Number of Liquids Loaded		Two (2)		
Maximum number of marine vessels, tank trucks, tank cars, and/or drums loading at one time:		Two (2)		
4. Does ballasting of marine vessels occur at this loading area?:				
<input type="checkbox"/> Yes <input type="checkbox"/> No <input checked="" type="checkbox"/> Does Not Apply				
5. Describe cleaning location, compounds and procedure for cargo vessels using this transfer point:				
na				
6. Are cargo vessels pressure tested for leaks at this or any other location?				
<input type="checkbox"/> Yes <input checked="" type="checkbox"/> No				
If YES, describe: na				
7. Projected Maximum Operating Schedule (for rack or transfer point as a whole):				
Maximum	Jan - Mar	Apr - Jun	Jul - Sep	Oct - Dec
hours/day	24	24	24	24
days/week	7	7	7	7
weeks/quarter	13	13	13	13

Appalachia Midstream Services, LLC (AMS)
Battle Run Compressor Station (BRCS)
 Application for 45CSR13 New Source Review Permit Modification (NSR)
Attachment L - Emission Unit Data Sheet

Bulk Liquid Transfer Operations - Continued

8. Bulk Liquid Data (add pages as necessary):		
Pump ID No.	SC	PW
Liquid Name	Stabilized Condensate (SC)	Produced Water (PW)
Max daily thruput (1,000 gal/day)	134	14
Max annual thruput (1,000 gal/yr)	9,965	1,533
Loading Method ¹	SUB	SUB
Max Fill Rate (gal/min)	150	150
Ave Fill Time (min/load)	60	60
Max Bulk Liquid Temperature (oF)	100	100
True Vapor Pressure ²	5.44	0.25
Cargo Vessel Condition ³	U	U
Control Equipment or Method ⁴	CA	None
Minimum Control Efficiency	66.5%	na
Maximum Emission Rate:	Loading (lb/hr)	11.97
	Annual (lb/yr)	17,035
Estimation Method ⁵	EPA	EPA
¹ BF = Bottom Fill SP = Splash Fill SUB = Submerged Fill		
² At maximum bulk liquid temperature		
³ B = Ballasted Vessel, C = Cleaned, U = Uncleaned (dedicated service), O = other (describe)		
⁴ List as many as apply (complete and submit appropriate Air Pollution Control Device Sheets): CA = Carbon Adsorption LOA = Lean Oil Adsorption CO = Condensation SC = Scrubber (Absorption) CRA = Compressor-Refrigeration-Absorption TO = Thermal Oxidation or Incineration CRC = Compression-Refrigeration-Condensation VB = Dedicated Vapor Balance (closed system) O = other (describe)		
⁵ EPA = EPA Emission Factor as stated in AP-42 MB = Material Balance TM = Test Measurement based upon test data submittal O = other (describe)		

Appalachia Midstream Services, LLC (AMS)
Battle Run Compressor Station (BRCS)
 Application for 45CSR13 New Source Review Permit Modification (NSR)
Attachment L - Emission Unit Data Sheet

Bulk Liquid Transfer Operations - Continued

9. Proposed Monitoring, Recordkeeping, Reporting, and Testing Please propose monitoring, recordkeeping, and reporting in order to demonstrate compliance with the proposed operating parameters. Please propose testing in order to demonstrate compliance with the proposed emissions limits.	
MONITORING	RECORDKEEPING
REPORTING	TESTING
MONITORING. PLEASE LIST AND DESCRIBE THE PROCESS PARAMETERS AND RANGES THAT ARE PROPOSED TO BE MONITORED IN ORDER TO DEMONSTRATE COMPLIANCE WITH THE OPERATION OF THIS PROCESS EQUIPMENT OPERATION/AIR POLLUTION CONTROL DEVICE.	
RECORDKEEPING. PLEASE DESCRIBE THE PROPOSED RECORDKEEPING THAT WILL ACCOMPANY THE MONITORING..	
RECORDKEEPING. PLEASE DESCRIBE THE PROPOSED FREQUENCY OF REPORTING OF THE RECORDKEEPING.	
TESTING. PLEASE DESCRIBE ANY PROPOSED EMISSIONS TESTING FOR THIS PROCESS EQUIPMENT/AIR POLLUTION CONTROL DEVICE.	
10. Describe all operating ranges and maintenance procedures required by Manufacturer to maintain warranty.	

Appalachia Midstream Services, LLC (AMS)
Battle Run Compressor Station (BRCS)
Application for 45CSR13 New Source Review Permit Modification (NSR)
Attachment L - Emission Unit Data Sheet

Bulk Liquid Transfer Operations

Proposed Permit Modifications

<i>Emission Unit Description</i>	TLO and WTLO
Proposed Modifications to WVDEP-DAQ Permit R13-2916A are shown below:	
10.1.1. Maximum Throughput Limitation. The maximum condensate throughput to the Condensate Truck Loading (ELOAD-1) shall not exceed 134.4×10^3 gal/day and 9.965×10^6 gal/yr. Compliance with the Maximum Throughput Limitation shall be determined using a twelve month rolling total. A twelve month rolling total shall mean the sum of the monthly throughput at any given time during the previous twelve consecutive calendar months.	
10.1.2. Maximum Throughput Limitation. The maximum produced water throughput to the Produced Water Truck Loading (ELOAD-2) shall not exceed 33.6×10^3 gal/day and 15.33 1.53 $\times 10^6$ gal/yr. Compliance with the Maximum Throughput Limitation shall be determined using a twelve-month rolling total. A twelve-month rolling total shall mean the sum of the monthly throughput at any given time during the previous twelve consecutive calendar months.	
10.1.3. The Condensate Truck Loading (ELOAD-1) and the Produced Water Truck Loading (ELOAD-2) shall be operated in accordance with the plans and specifications filed in Permit Application R13-2916. All emissions from the Condensate Truck Loading (ELOAD-1) and the Produced Water Truck Loading (ELOAD-2) will be controlled by a carbon canister (APC-CARBON) that shall be designed to achieve a minimum guaranteed control efficiency of 95% for volatile organic compound (VOC) emissions.	
10.1.4. The carbon canister (APC-CARBON) must be operated at all times when gases, vapors, and fumes are vented from the Condensate Truck Loading (ELOAD-1) and the Produced Water Truck Loading (ELOAD-2) . In addition, the carbon canister must be operated in series, as dual carbon canisters, in case of emission breakthrough in one carbon canister.	

Appalachia Midstream Services, LLC (AMS)
Battle Run Compressor Station (BRCS)
Application for 45CSR13 New Source Review Permit Modification (NSR)
Attachment L - Emission Unit Data Sheet

Leak Source Data Sheet

Source Category	Pollutant	Number of Source Components ¹	Number of Components Monitored by Frequency ²	Average Time to Repair (Days) ³	Estimated Annual Emission Rate (lb/yr) ⁴
Pumps⁵	Light Liquid VOC ^{6,7}	18	na	na	0.52
	Heavy Liquid VOC ⁸	---	---	---	---
	Non-VOC ⁹	---	---	---	---
Valves¹⁰	Gas VOC	1,440	na	na	3.58
	Light Liquid VOC	864	na	na	4.76
	Heavy Liquid VOC	---	---	---	---
	Non-VOC	---	---	---	---
Safety Relief Valves¹¹	Gas VOC	See "Other"	na	na	---
	Light Liquid VOC	See "Other"	na	na	---
	Non-VOC	---	---	---	---
Open Ended Lines¹²	Gas VOC	50	na	na	0.06
	Light Liquid VOC	30	na	na	0.09
	Non-VOC	---	---	---	---
Sampling Connections¹³	Gas VOC	See "Open Ended Lines"	na	na	---
	Light Liquid VOC	See "Open Ended Lines"	na	na	---
	Non-VOC	---	---	---	---
Compressors	Gas VOC	See "Other"	na	na	---
	Non-VOC	---	---	---	---
Flanges	Gas VOC	1,175	na	na	0.25
	Light Liquid VOC	486	na	na	0.12
	Non-VOC	---	---	---	---
Connectors	Gas VOC	4,699	na	na	0.52
	Light Liquid VOC	1,944	na	na	0.90
	Non-VOC	---	---	---	---
Other	Gas VOC	108	na	na	0.53
	Light Liquid VOC	65	na	na	1.07
	Non-VOC	---	---	---	---

Appalachia Midstream Services, LLC (AMS)
Battle Run Compressor Station (BRCS)
Application for 45CSR13 New Source Review Permit Modification (NSR)
Attachment L - Emission Unit Data Sheet
Notes for Leak Source Data Sheet

Notes for Leak Source Data Sheet

1. For VOC sources include components on streams and equipment that contain greater than 10% VOC, including feed streams, reaction/separation facilities, and product/by-product delivery lines. Do not include certain leakless equipment as defined below by category.
2. By monitoring frequency, give the number of sources routinely monitored for leaks, using a portable detection device that measures concentration in visual or soap-bubble leak detection ppm. Do not include monitoring by methods. "M/Q(M)/Q/SA/A/0" means the time period between inspections as follows:
Monthly/Quarterly, with Monthly follow-up of repaired leakers/Quarterly/Semi-annual/Annually/other (specify time period)

If source category is not monitored, a single zero in the space will suffice. For example, if 50 gas-service valves are monitored quarterly, with monthly follow-up of those repaired, 75 are monitored semi-annually, and 50 are checked bimonthly (alternate months), with non checked at any other frequency, you would put in the category valves, gas service: 0/50/0/75/0/50 (bimonthly).
3. Give the average number of days, after a leak is discovered, that an attempt will be made to repair the leak.
4. Note the method used: MB - material balance; EE - engineering estimate; EPA - emission factors established by EPA (cite document used); 0 - other method, such as in-house emission factor (specify).
5. Do not include in the equipment count seal-less pumps (canned motor or diaphragm) or those with enclosed venting to a control device. (Emissions from vented equipment should be included in the estimates given in the Emission Points Data Sheet.)
6. Volatile organic compounds (VOC) means the term as defined in 40 CFR. 51.100 (s).
7. A light liquid is defined as a fluid with vapor pressure equal to or greater than 0.04 psi (0.3 Kpa) at 20°C. For mixtures, if 20% w/w or more of the stream is composed of fluids with vapor pressures greater than 0.04 psi (0.3 Kpa) at 20°C, then the fluid is defined as a light liquid.
8. A heavy liquid is defined as a fluid with a vapor pressure less than 0.04 psi (0.3 Kpa) at 20°C. For mixtures, if less than 20% w/w of the stream is composed of fluids with vapor pressures greater than 0.04 psi (0.3 Kpa) at 20°C. then the fluid is defined as a heavy liquid.
9. LIST CO, H₂S, mineral acids, NO, NO₂, SO₂, etc. DO NOT LIST CO, H₂, N₂, O₂, and Noble Gases.
10. Include all process valves whether in-line or on an open-ended line such as sample, drain and purge valves. Do not include safety-relief valves, or leakless valves such as check, diaphragm, and bellows seal valves.
11. Do not include a safety-relief valve if there is a rupture disk in place upstream of the valve, or if the valve vents to a control device.
12. Open-ended lines include purge, drain and vent lines. Do not include sampling connections, or lines sealed by plugs, caps, blinds or second valves.
13. Do not include closed-purge sampling connections.

Attachment M
Air Pollution Control Device Sheet(s)

“29. Fill out the **Air Pollution Control Device Sheet(s)** as Attachment M.”

- **Oxidation Catalyst (OxCat-01 thru OxCat-12) (Serves CE-01 thru CE-12)**
 - **Non-Selective Catalytic Reduction (NSCR) (Serves GEN)**
 - **BTEX Buster/Condenser (BTEX-01 thru BTEX-03) (Serves DHY-01 thru DHY-03)**
 - **Vapor Recovery Unit (VRU) (Serves TK-01 thru TK-08)**
 - **Carbon Canister (CarbCan) (Serves TLO)**
-

Appalachia Midstream Services, LLC (AMS)
Battle Run Compressor Station (BRCS)
 Application for 45CSR13 New Source Review Permit Modification (NSR)

Attachment M

**Air Pollution Control Device (APCD) Sheet
 (OxCat)**

Control Device Unit No. (must match Emission Units Table):

OxCat-01 thru OxCat-12 (Each)

Equipment Information

1. Manufacturer: EMIT Technologies	2. Control Device Name: Oxidation Catalyst (OxCat) (Each of 12) (Controls CE-01 thru CE-12)																		
3. Provide diagram(s) of unit describing capture system with duct arrangement and size of duct, air volume, capacity, horsepower of movers. If applicable, state hood face velocity and hood collection efficiency.																			
4. On a separate sheet(s) supply all data and calculations used in selecting or designing this collection device.																			
5. Provide a scale diagram of the control device showing internal construction.																			
6. Submit a schematic and diagram with dimensions and flow rates.																			
7. Guaranteed minimum collection efficiency for each pollutant collected: <div style="display: flex; justify-content: space-around; text-align: center;"> CO 100% NMNEHC 100% HCHO 100% </div>																			
8. Attached efficiency curve and/or other efficiency information.																			
9. Design inlet volume: 9,227 acfm	10. Capacity: na																		
11. Indicate the liquid flow rate and describe equipment provided to measure pressure drop and flow rate, if any. na																			
12. Attach any additional data including auxiliary equipment and operation details to thoroughly evaluate the control equipment. na																			
13. Description of method of handling the collected material(s) for reuse or disposal. na																			
Gas Stream Characteristics																			
14. Are halogenated organics present? <input type="checkbox"/> Yes <input checked="" type="checkbox"/> No Are particulates present? <input type="checkbox"/> Yes <input checked="" type="checkbox"/> No Are metals present? <input type="checkbox"/> Yes <input checked="" type="checkbox"/> No																			
15. Inlet emission stream parameters:	<table border="1" style="width: 100%; border-collapse: collapse;"> <thead> <tr> <th style="width: 30%;"></th> <th style="width: 35%; text-align: center;">Maximum</th> <th style="width: 35%; text-align: center;">Typical</th> </tr> </thead> <tbody> <tr> <td>Pressure (mmHg):</td> <td style="text-align: center;">na</td> <td style="text-align: center;">na</td> </tr> <tr> <td>Heat Content (BTU/scf):</td> <td style="text-align: center;">na</td> <td style="text-align: center;">na</td> </tr> <tr> <td>Oxygen Content (%):</td> <td style="text-align: center;">na</td> <td style="text-align: center;">na</td> </tr> <tr> <td>Moisture Content (%):</td> <td style="text-align: center;">na</td> <td style="text-align: center;">na</td> </tr> <tr> <td>Relative Humidity (%):</td> <td style="text-align: center;">na</td> <td style="text-align: center;">na</td> </tr> </tbody> </table>		Maximum	Typical	Pressure (mmHg):	na	na	Heat Content (BTU/scf):	na	na	Oxygen Content (%):	na	na	Moisture Content (%):	na	na	Relative Humidity (%):	na	na
	Maximum	Typical																	
Pressure (mmHg):	na	na																	
Heat Content (BTU/scf):	na	na																	
Oxygen Content (%):	na	na																	
Moisture Content (%):	na	na																	
Relative Humidity (%):	na	na																	

Battle Run Compressor Station (BRCS)

Application for 45CSR13 New Source Review Permit Modification (NSR)

Attachment M**Air Pollution Control Device (APCD) Sheet
(OxCat)**

Control Device Unit No. (must match Emission Units Table):

OxCat-01 thru OxCat-12 (Each)

Equipment Information - Continued

16. Type of pollutant(s) controlled: <input type="checkbox"/> SO2 <input type="checkbox"/> Odor						
<input type="checkbox"/> PM <input checked="" type="checkbox"/> Other: CO, NMNEHC/VOC, HCHO						
17. Inlet gas velocity: na			18. Pollutant specific gravity: varies			
19. Gas flow into the collector: 9,227 ACFM			20. Gas stream temperature: Inlet: 1,024 oF Outlet: na oF			
21. Gas flow rate: Design Maximum: 9,227 ACFM Average Expected: 9,227 ACFM			22. Particulate Grain Loading: Inlet: na grains/scf Outlet: na grains/scf			
23. Emission rate of each pollutant (specify) into and out of collector:						
Pollutant	IN Pollutant		Capture Efficiency	OUT Pollutant		Control Efficiency
	g/bhp-hr	lb/hr		g/bhp-hr	lb/hr	
CO	3.10	9.43	100%	0.47	1.41	85.0%
NMNEHC (VOC w/o HCHO)	1.04	3.16	100%	0.21	0.63	80.0%
VOC (including HCHO)	1.45	4.41	100%	0.25	0.77	82.5%
HCHO	0.36	1.10	100%	0.04	0.11	90.0%
24. Dimensions of stack: Height: 20.0 ft Diameter: 1.0 ft						
25. Supply a curve showing proposed collection efficiency versus gas volume from 25 to 130 percent of design rating of collector.						
26. Complete the table:		Particle Size Distribution		Fraction Efficiency of Collector		
Particulate Size Range (microns)		Weight % for Size Range		Weight % for Size Range		
0 – 2		na		na		
2 – 4		na		na		
4 – 6		na		na		
6 – 8		na		na		
8 – 10		na		na		
10 – 12		na		na		
12 – 16		na		na		
16 – 20		na		na		
20 – 30		na		na		
30 – 40		na		na		
40 – 50		na		na		
50 – 60		na		na		
60 – 70		na		na		
70 – 80		na		na		
80 – 90		na		na		
90 – 100		na		na		
>100		na		na		

Attachment M

**Air Pollution Control Device (APCD) Sheet
 (OxCat)**

Control Device Unit No. (must match Emission Units Table):

OxCat-01 thru OxCat-12 (Each)

Equipment Information - Continued

27. Describe any air pollution control device inlet and outlet gas conditioning processes (e.g., gas cooling, gas reheating, gas humidification): na	
28. Describe the collection material disposal system: na	
29. Describe the collection material disposal system: na	
30. Proposed Monitoring, Recordkeeping, Reporting, and Testing Please propose monitoring, recordkeeping, and reporting in order to demonstrate compliance with the proposed operating parameters. Please propose testing in order to demonstrate compliance with the proposed emissions limits.	
MONITORING: As per NSPS JJJJ and Current Permit	RECORDKEEPING: As per NSPS JJJJ and Current Permit
REPORTING: As per NSPS JJJJ and Current Permit	TESTING: As per NSPS JJJJ and Current Permit
MONITORING:	Please list and describe the process parameters and ranges that are proposed to be monitored in order to demonstrate compliance with the operation of this process equipment or air control device.
RECORDKEEPING	Please describe the proposed recordkeeping that will accompany the monitoring.
REPORTING	Please describe any proposed emissions testing for this process equipment on air pollution control device.
TESTING	Please describe any proposed emissions testing for this process equipment on air pollution control device.
31. Manufacturer's Guaranteed <u>Collection</u> Efficiency for each air pollutant.	
CO	100%
NMNEHC/VOC	100%
HCHO	100%
32. Manufacturer's Guaranteed <u>Control</u> Efficiency for each air pollutant.	
CO	≥ 85%
NMNEHC/VOC	≥ 80%
HCHO	≥ 90%
33. Describe all operating ranges and maintenance procedures required by Manufacturer to maintain warranty. na	

Appalachia Midstream Services, LLC (AMS)
Battle Run Compressor Station (BRCS)
 Application for 45CSR13 New Source Review Permit Modification (NSR)

Attachment M

**Air Pollution Control Device (APCD) Sheet
(NSCR)**

Control Device Unit No. (must match Emission Units Table):

NSCR

Equipment Information

1. Manufacturer: ---	2. Control Device Name: Non-Selective Catalytic Reduction (NSCR) (Controls GEN)		
3. Provide diagram(s) of unit describing capture system with duct arrangement and size of duct, air volume, capacity, horsepower of movers. If applicable, state hood face velocity and hood collection efficiency.			
4. On a separate sheet(s) supply all data and calculations used in selecting or designing this collection device.			
5. Provide a scale diagram of the control device showing internal construction.			
6. Submit a schematic and diagram with dimensions and flow rates.			
7. Guaranteed minimum collection efficiency for each pollutant collected: NOX 100% CO 100%			
8. Attached efficiency curve and/or other efficiency information.			
9. Design inlet volume: 2,995 acfm	10. Capacity: na		
11. Indicate the liquid flow rate and describe equipment provided to measure pressure drop and flow rate, if any. na			
12. Attach any additional data including auxiliary equipment and operation details to thoroughly evaluate the control equipment. na			
13. Description of method of handling the collected material(s) for reuse or disposal. na			
Gas Stream Characteristics			
14. Are halogenated organics present? <input type="checkbox"/> Yes <input checked="" type="checkbox"/> No Are particulates present? <input type="checkbox"/> Yes <input checked="" type="checkbox"/> No Are metals present? <input type="checkbox"/> Yes <input checked="" type="checkbox"/> No			
15. Inlet emission stream parameters:	Maximum	Typical	
	Pressure (mmHg):	na	na
	Heat Content (BTU/scf):	na	na
	Oxygen Content (%):	na	na
	Moisture Content (%):	na	na
Relative Humidity (%):	na	na	

Attachment M

**Air Pollution Control Device (APCD) Sheet
(NSCR)**

Control Device Unit No. (must match Emission Units Table):

NSCR

Equipment Information - Continued

16. Type of pollutant(s) controlled: <input type="checkbox"/> SO2 <input type="checkbox"/> Odor <input type="checkbox"/> PM <input checked="" type="checkbox"/> Other: NOX, CO						
17. Inlet gas velocity: na			18. Pollutant specific gravity: varies			
19. Gas flow into the collector: 2,995 ACFM			20. Gas stream temperature: Inlet: 1,382 oF Outlet: na oF			
21. Gas flow rate: Design Maximum: 2,995 ACFM Average Expected: 2,995 ACFM			22. Particulate Grain Loading: Inlet: na grains/scf Outlet: na grains/scf			
23. Emission rate of each pollutant (specify) into and out of collector:						
Pollutant	IN Pollutant		Capture Efficiency	OUT Pollutant		Control Efficiency
	g/bhp-hr	lb/hr		g/bhp-hr	lb/hr	
NOX	7.51	10.01	100%	1.00	1.33	86.7%
CO	12.63	16.85	100%	2.00	2.67	84.2%
24. Dimensions of stack: Height: 20.0 ft Diameter: 1.0 ft						
25. Supply a curve showing proposed collection efficiency versus gas volume from 25 to 130 percent of design rating of collector.						
26. Complete the table:		Particle Size Distribution		Fraction Efficiency of Collector		
Particulate Size Range (microns)		Weight % for Size Range		Weight % for Size Range		
0 – 2		na		na		
2 – 4		na		na		
4 – 6		na		na		
6 – 8		na		na		
8 – 10		na		na		
10 – 12		na		na		
12 – 16		na		na		
16 – 20		na		na		
20 – 30		na		na		
30 – 40		na		na		
40 – 50		na		na		
50 – 60		na		na		
60 – 70		na		na		
70 – 80		na		na		
80 – 90		na		na		
90 – 100		na		na		
>100		na		na		

Attachment M

**Air Pollution Control Device (APCD) Sheet
 (NSCR)**

Control Device Unit No. (must match Emission Units Table):

NSCR

Equipment Information - Continued

27. Describe any air pollution control device inlet and outlet gas conditioning processes (e.g., gas cooling, gas reheating, gas humidification): na					
28. Describe the collection material disposal system: na					
29. Describe the collection material disposal system: na					
30. Proposed Monitoring, Recordkeeping, Reporting, and Testing Please propose monitoring, recordkeeping, and reporting in order to demonstrate compliance with the proposed operating parameters. Please propose testing in order to demonstrate compliance with the proposed emissions limits.					
MONITORING: As per NSPS JJJJ and Current Permit	RECORDKEEPING: As per NSPS JJJJ and Current Permit				
REPORTING: As per NSPS JJJJ and Current Permit	TESTING: As per NSPS JJJJ and Current Permit				
MONITORING:	Please list and describe the process parameters and ranges that are proposed to be monitored in order to demonstrate compliance with the operation of this process equipment or air control device.				
RECORDKEEPING	Please describe the proposed recordkeeping that will accompany the monitoring.				
REPORTING	Please describe any proposed emissions testing for this process equipment on air pollution control device.				
TESTING	Please describe any proposed emissions testing for this process equipment on air pollution control device.				
31. Manufacturer's Guaranteed <u>Collection</u> Efficiency for each air pollutant. <table style="width: 100%; border: none;"> <tr> <td style="text-align: center;">NOX</td> <td style="text-align: center;">100%</td> <td style="text-align: center;">CO</td> <td style="text-align: center;">100%</td> </tr> </table>		NOX	100%	CO	100%
NOX	100%	CO	100%		
32. Manufacturer's Guaranteed <u>Control</u> Efficiency for each air pollutant. <table style="width: 100%; border: none;"> <tr> <td style="text-align: center;">NOX</td> <td style="text-align: center;">≥ 86.7%</td> <td style="text-align: center;">CO</td> <td style="text-align: center;">≥ 84.2%</td> </tr> </table>		NOX	≥ 86.7%	CO	≥ 84.2%
NOX	≥ 86.7%	CO	≥ 84.2%		
33. Describe all operating ranges and maintenance procedures required by Manufacturer to maintain warranty. na					

Appalachia Midstream Services, LLC (AMS)
Battle Run Compressor Station (BRCS)
 Application for 45CSR13 New Source Review Permit Modification (NSR)

Attachment M

**Air Pollution Control Device (APCD) Sheet
 (Condenser)**

Control Device Unit No. (must match Emission Units Table):

BTEX-01 thru BTEX-03

Equipment Information

1. Manufacturer: NATCO	2. Control Device Name: BETX Buster (Condenser) (Controls DHY-01 thru DHY-03)																		
3. Provide diagram(s) of unit describing capture system with duct arrangement and size of duct, air volume, capacity, horsepower of movers. If applicable, state hood face velocity and hood collection efficiency.																			
4. On a separate sheet(s) supply all data and calculations used in selecting or designing this collection device.																			
5. Provide a scale diagram of the control device showing internal construction.																			
6. Submit a schematic and diagram with dimensions and flow rates.																			
7. Guaranteed minimum collection efficiency for each pollutant collected: <div style="text-align: center;"> VOC 100% V-HAP 100% </div>																			
8. Attached efficiency curve and/or other efficiency information.																			
9. Design inlet volume: 2,570 SCFH	10. Capacity: na																		
11. Indicate the liquid flow rate and describe equipment provided to measure pressure drop and flow rate, if any. na																			
12. Attach any additional data including auxiliary equipment and operation details to thoroughly evaluate the control equipment. na																			
13. Description of method of handling the collected material(s) for reuse or disposal. na																			
Gas Stream Characteristics																			
14. Are halogenated organics present? <input type="checkbox"/> Yes <input checked="" type="checkbox"/> No Are particulates present? <input type="checkbox"/> Yes <input checked="" type="checkbox"/> No Are metals present? <input type="checkbox"/> Yes <input checked="" type="checkbox"/> No																			
15. Inlet emission stream parameters:	<table border="1" style="width: 100%; border-collapse: collapse;"> <thead> <tr> <th style="width: 50%;"></th> <th style="width: 25%;">Maximum</th> <th style="width: 25%;">Typical</th> </tr> </thead> <tbody> <tr> <td>Pressure (mmHg):</td> <td style="text-align: center;">na</td> <td style="text-align: center;">na</td> </tr> <tr> <td>Heat Content (BTU/scf):</td> <td style="text-align: center;">na</td> <td style="text-align: center;">na</td> </tr> <tr> <td>Oxygen Content (%):</td> <td style="text-align: center;">na</td> <td style="text-align: center;">na</td> </tr> <tr> <td>Moisture Content (%):</td> <td style="text-align: center;">na</td> <td style="text-align: center;">na</td> </tr> <tr> <td>Relative Humidity (%):</td> <td style="text-align: center;">na</td> <td style="text-align: center;">na</td> </tr> </tbody> </table>		Maximum	Typical	Pressure (mmHg):	na	na	Heat Content (BTU/scf):	na	na	Oxygen Content (%):	na	na	Moisture Content (%):	na	na	Relative Humidity (%):	na	na
	Maximum	Typical																	
Pressure (mmHg):	na	na																	
Heat Content (BTU/scf):	na	na																	
Oxygen Content (%):	na	na																	
Moisture Content (%):	na	na																	
Relative Humidity (%):	na	na																	

Attachment M

**Air Pollution Control Device (APCD) Sheet
 (Condenser)**

Control Device Unit No. (must match Emission Units Table):

BTEX-01 thru BTEX-03

Equipment Information - Continued

16. Type of pollutant(s) controlled: <input type="checkbox"/> SO2 <input type="checkbox"/> Odor <input type="checkbox"/> PM <input checked="" type="checkbox"/> Other: VOC, V-HAP						
17. Inlet gas velocity: na			18. Pollutant specific gravity: varies			
19. Gas flow into the collector: 2,570 SCFH			20. Gas stream temperature: Inlet: 212 oF Outlet: 120 oF			
21. Gas flow rate: Design Maximum: 2,570 SCFH Average Expected: 2,570 SCFH			22. Particulate Grain Loading: Inlet: na grains/scf Outlet: na grains/scf			
23. Emission rate of each pollutant (specify) into and out of collector:						
Pollutant	IN Pollutant		Capture Efficiency	OUT Pollutant		Control Efficiency
	lb/yr	tpy		lb/yr	tpy	
VOC	49.21	215.55	100%	1.89	8.29	96.2%
TOTAL HAP	10.73	46.99	100%	0.30	1.34	97.2%
24. Dimensions of stack: Height: na Diameter: na						
25. Supply a curve showing proposed collection efficiency versus gas volume from 25 to 130 percent of design rating of collector.						
26. Complete the table:	Particle Size Distribution		Fraction Efficiency of Collector			
Particulate Size Range (microns)	Weight % for Size Range		Weight % for Size Range			
0 – 2	na		na			
2 – 4	na		na			
4 – 6	na		na			
6 – 8	na		na			
8 – 10	na		na			
10 – 12	na		na			
12 – 16	na		na			
16 – 20	na		na			
20 – 30	na		na			
30 – 40	na		na			
40 – 50	na		na			
50 – 60	na		na			
60 – 70	na		na			
70 – 80	na		na			
80 – 90	na		na			
90 – 100	na		na			
>100	na		na			

Attachment M

**Air Pollution Control Device (APCD) Sheet
 (Condenser)**

Control Device Unit No. (must match Emission Units Table):

BTEX-01 thru BTEX-03

Equipment Information - Continued

27. Describe any air pollution control device inlet and outlet gas conditioning processes (e.g., gas cooling, gas reheating, gas humidification):

Exhaust Gases are Burned as Fuel (Recycle) or Recompressed (Reclaimed)

28. Describe the collection material disposal system:

Condensed Liquids are pumped to the Stabilized Condensate Storage Tanks (TK-01 thru TK-08)

29. Describe the collection material disposal system:

na

30. Proposed Monitoring, Recordkeeping, Reporting, and Testing

Please propose monitoring, recordkeeping, and reporting in order to demonstrate compliance with the proposed operating parameters. Please propose testing in order to demonstrate compliance with the proposed emissions limits.

MONITORING:

As per Current Permit

RECORDKEEPING:

As per Current Permit

REPORTING:

As per Current Permit

TESTING:

As per Current Permit

MONITORING:

Please list and describe the process parameters and ranges that are proposed to be monitored in order to demonstrate compliance with the operation of this process equipment or air control device.

RECORDKEEPING

Please describe the proposed recordkeeping that will accompany the monitoring.

REPORTING

Please describe any proposed emissions testing for this process equipment on air pollution control device.

TESTING

Please describe any proposed emissions testing for this process equipment on air pollution control device.

31. Manufacturer's Guaranteed Collection Efficiency for each air pollutant.

na

32. Manufacturer's Guaranteed Control Efficiency for each air pollutant.

na

33. Describe all operating ranges and maintenance procedures required by Manufacturer to maintain warranty.

na

Appalachia Midstream Services, LLC (AMS)
Battle Run Compressor Station (BRCS)
 Application for 45CSR13 New Source Review Permit Modification (NSR)

Attachment M

**Air Pollution Control Device (APCD) Sheet
 (VRU)**

Control Device Unit No. (must match Emission Units Table):

VRU

Equipment Information

1. Manufacturer: na	2. Control Device Name: Vapor Recovery Unit (VRU) (Controls TK-01 thru TK-08)
3. Provide diagram(s) of unit describing capture system with duct arrangement and size of duct, air volume, capacity, horsepower of movers. If applicable, state hood face velocity and hood collection efficiency.	
4. On a separate sheet(s) supply all data and calculations used in selecting or designing this collection device.	
5. Provide a scale diagram of the control device showing internal construction.	
6. Submit a schematic and diagram with dimensions and flow rates.	
7. Guaranteed minimum <u>collection</u> efficiency for each pollutant collected: na	
8. Attached efficiency curve and/or other efficiency information.	
9. Design inlet volume: na	10. Capacity: na
11. Indicate the liquid flow rate and describe equipment provided to measure pressure drop and flow rate, if any. na	
12. Attach any additional data including auxiliary equipment and operation details to thoroughly evaluate the control equipment. na	
13. Description of method of handling the collected material(s) for reuse or disposal. na	

Gas Stream Characteristics

14. Are halogenated organics present?	<input type="checkbox"/> Yes	<input checked="" type="checkbox"/> No	
Are particulates present?	<input type="checkbox"/> Yes	<input checked="" type="checkbox"/> No	
Are metals present?	<input type="checkbox"/> Yes	<input checked="" type="checkbox"/> No	
15. Inlet emission stream parameters:	Maximum	Typical	
	Pressure (mmHg):	na	na
	Heat Content (BTU/scf):	na	na
	Oxygen Content (%):	na	na
	Moisture Content (%):	na	na
Relative Humidity (%):	na	na	

Appalachia Midstream Services, LLC (AMS)
Battle Run Compressor Station (BRCS)
 Application for 45CSR13 New Source Review Permit Modification (NSR)

Attachment M

**Air Pollution Control Device (APCD) Sheet
(VRU)**

Control Device Unit No. (must match Emission Units Table):

VRU

Equipment Information - Continued

16. Type of pollutant(s) controlled: <input type="checkbox"/> SO2 <input type="checkbox"/> Odor <input type="checkbox"/> PM <input checked="" type="checkbox"/> Other: VOC, V-HAP						
17. Inlet gas velocity: na			18. Pollutant specific gravity: varies			
19. Gas flow into the collector: na			20. Gas stream temperature: Inlet: na Outlet: na			
21. Gas flow rate: Design Maximum: na Average Expected: na			22. Particulate Grain Loading: Inlet: na Outlet: na			
23. Emission rate of each pollutant (specify) into and out of collector:						
Pollutant	IN Pollutant		Capture Efficiency	OUT Pollutant		Control Efficiency
	lb/yr	tpy		lb/yr	tpy	
VOC	6.16	26.97	100%	0.31	1.35	95%
TOTAL HAP	1.85	8.09	100%	0.09	0.40	95%
24. Dimensions of stack: Height: na Diameter: na						
25. Supply a curve showing proposed collection efficiency versus gas volume from 25 to 130 percent of design rating of collector.						
26. Complete the table:						
Particulate Size Range (microns)	Particle Size Distribution		Fraction Efficiency of Collector			
	Weight % for Size Range		Weight % for Size Range			
0 – 2	na		na			
2 – 4	na		na			
4 – 6	na		na			
6 – 8	na		na			
8 – 10	na		na			
10 – 12	na		na			
12 – 16	na		na			
16 – 20	na		na			
20 – 30	na		na			
30 – 40	na		na			
40 – 50	na		na			
50 – 60	na		na			
60 – 70	na		na			
70 – 80	na		na			
80 – 90	na		na			
90 – 100	na		na			
>100	na		na			

Appalachia Midstream Services, LLC (AMS)
Battle Run Compressor Station (BRCS)
 Application for 45CSR13 New Source Review Permit Modification (NSR)
Attachment M

**Air Pollution Control Device (APCD) Sheet
 (VRU)**

Control Device Unit No. (must match Emission Units Table):

VRU

Equipment Information - Continued

27. Describe any air pollution control device inlet and outlet gas conditioning processes (e.g., gas cooling, gas reheating, gas humidification): <p style="text-align: center;">Exhaust Gases are Burned as Fuel (Recycle) or Recompressed (Reclaimed)</p>	
28. Describe the collection material disposal system: <p style="text-align: center;">Condensed Liquids are returned to the Stabilized Condensate Storage Tanks (TK-01 thru TK-08)</p>	
29. Describe the collection material disposal system: na	
30. Proposed Monitoring, Recordkeeping, Reporting, and Testing Please propose monitoring, recordkeeping, and reporting in order to demonstrate compliance with the proposed operating parameters. Please propose testing in order to demonstrate compliance with the proposed emissions limits.	
MONITORING: <p style="text-align: center;">As per Current Permit (Except Remove WTK-01 and WTK-02)</p>	RECORDKEEPING: <p style="text-align: center;">As per Current Permit (Except Remove WTK-01 and WTK-02)</p>
REPORTING: <p style="text-align: center;">As per Current Permit (Except Remove WTK-01 and WTK-02)</p>	TESTING: <p style="text-align: center;">As per Current Permit (Except Remove WTK-01 and WTK-02)</p>
MONITORING:	Please list and describe the process parameters and ranges that are proposed to be monitored in order to demonstrate compliance with the operation of this process equipment or air control device.
RECORDKEEPING	Please describe the proposed recordkeeping that will accompany the monitoring.
REPORTING	Please describe any proposed emissions testing for this process equipment on air pollution control device.
TESTING	Please describe any proposed emissions testing for this process equipment on air pollution control device.
31. Manufacturer's Guaranteed <u>Collection</u> Efficiency for each air pollutant. <p style="text-align: center;">na</p>	
32. Manufacturer's Guaranteed <u>Control</u> Efficiency for each air pollutant. <p style="text-align: center;">na</p>	
33. Describe all operating ranges and maintenance procedures required by Manufacturer to maintain warranty. <p style="text-align: center;">na</p>	

Appalachia Midstream Services, LLC (AMS)
Battle Run Compressor Station (BRCS)
 Application for 45CSR13 New Source Review Permit Modification (NSR)

Attachment M

**Air Pollution Control Device (APCD) Sheet
 (Adsorption)**

Control Device Unit No. (must match Emission Units Table):

CarbCan

Equipment Information

1. Manufacturer: na	2. Control Device Name: Carbon Canister (Controls TLO)
3. Provide diagram(s) of unit describing capture system with duct arrangement and size of duct, air volume, capacity, horsepower of movers. If applicable, state hood face velocity and hood collection efficiency.	
4. On a separate sheet(s) supply all data and calculations used in selecting or designing this collection device.	
5. Provide a scale diagram of the control device showing internal construction.	
6. Submit a schematic and diagram with dimensions and flow rates.	
7. Guaranteed minimum collection efficiency for each pollutant collected: VOC: 70% V-HAP: 70%	
8. Attached efficiency curve and/or other efficiency information.	
9. Design inlet volume: na	10. Capacity: na
11. Indicate the liquid flow rate and describe equipment provided to measure pressure drop and flow rate, if any. na	
12. Attach any additional data including auxiliary equipment and operation details to thoroughly evaluate the control equipment. na	
13. Description of method of handling the collected material(s) for reuse or disposal. na	

Gas Stream Characteristics

14. Are halogenated organics present?	<input type="checkbox"/> Yes	<input checked="" type="checkbox"/> No	
Are particulates present?	<input type="checkbox"/> Yes	<input checked="" type="checkbox"/> No	
Are metals present?	<input type="checkbox"/> Yes	<input checked="" type="checkbox"/> No	
15. Inlet emission stream parameters:	Maximum	Typical	
	Pressure (mmHg):	na	na
	Heat Content (BTU/scf):	na	na
	Oxygen Content (%):	na	na
	Moisture Content (%):	na	na
Relative Humidity (%):	na	na	

Appalachia Midstream Services, LLC (AMS)
Battle Run Compressor Station (BRCS)
Application for 45CSR13 New Source Review Permit Modification (NSR)

Attachment M

**Air Pollution Control Device (APCD) Sheet
(Adsorption)**

Control Device Unit No. (must match Emission Units Table):

CarbCan

Equipment Information - Continued

16. Type of pollutant(s) controlled:						
<input type="checkbox"/> SO ₂		<input type="checkbox"/> Odor				
<input type="checkbox"/> PM		<input checked="" type="checkbox"/> Other: VOC, V-HAP				
17. Inlet gas velocity: na			18. Pollutant specific gravity: varies			
19. Gas flow into the collector:			20. Gas stream temperature:			
na			Inlet:		na	
			Outlet:		na	
21. Gas flow rate:			22. Particulate Grain Loading:			
Design Maximum:		na		Inlet:		na
Average Expected:		na		Outlet:		na
23. Emission rate of each pollutant (specify) into and out of collector:						
Pollutant	IN Pollutant		Capture Efficiency	OUT Pollutant		Control Efficiency
	lb/yr	tpy		lb/yr	tpy	
VOC	35.72	25.43	70%	11.97	8.52	95%
TOTAL HAP	10.72	7.63	70%	3.59	2.56	95%
24. Dimensions of stack: Height: 4.0 ft Diameter: 0.3 ft						
25. Supply a curve showing proposed collection efficiency versus gas volume from 25 to 130 percent of design rating of collector.						
26. Complete the table:						
Particle Size Distribution		Fraction Efficiency of Collector				
Particulate Size Range (microns)		Weight % for Size Range			Weight % for Size Range	
0 – 2		na			na	
2 – 4		na			na	
4 – 6		na			na	
6 – 8		na			na	
8 – 10		na			na	
10 – 12		na			na	
12 – 16		na			na	
16 – 20		na			na	
20 – 30		na			na	
30 – 40		na			na	
40 – 50		na			na	
50 – 60		na			na	
60 – 70		na			na	
70 – 80		na			na	
80 – 90		na			na	
90 – 100		na			na	
>100		na			na	

Attachment M

**Air Pollution Control Device (APCD) Sheet
 (Adsorption)**

Control Device Unit No. (must match Emission Units Table):

CarbCan

Equipment Information - Continued

27. Describe any air pollution control device inlet and outlet gas conditioning processes (e.g., gas cooling, gas reheating, gas humidification): na	
28. Describe the collection material disposal system: <p style="text-align: center;">The Carbon Canisters (CarbCan) are returned to the manufacture for regeneration as requisite.</p>	
29. Describe the collection material disposal system: na	
30. Proposed Monitoring, Recordkeeping, Reporting, and Testing Please propose monitoring, recordkeeping, and reporting in order to demonstrate compliance with the proposed operating parameters. Please propose testing in order to demonstrate compliance with the proposed emissions limits.	
MONITORING: <p style="text-align: center;">As per Current Permit (Except Remove WTLO)</p>	RECORDKEEPING: <p style="text-align: center;">As per Current Permit (Except Remove WTLO)</p>
REPORTING: <p style="text-align: center;">As per Current Permit (Except Remove WTLO)</p>	TESTING: <p style="text-align: center;">As per Current Permit (Except Remove WTLO)</p>
MONITORING:	Please list and describe the process parameters and ranges that are proposed to be monitored in order to demonstrate compliance with the operation of this process equipment or air control device.
RECORDKEEPING	Please describe the proposed recordkeeping that will accompany the monitoring.
REPORTING	Please describe any proposed emissions testing for this process equipment on air pollution control device.
TESTING	Please describe any proposed emissions testing for this process equipment on air pollution control device.
31. Manufacturer's Guaranteed <u>Collection</u> Efficiency for each air pollutant. na	
32. Manufacturer's Guaranteed <u>Control</u> Efficiency for each air pollutant. na	
33. Describe all operating ranges and maintenance procedures required by Manufacturer to maintain warranty. na	

Attachment N

Emissions Calculations

“30. Provide all **Supporting Emissions Calculations** as Attachment N.”

- **Emission Summary Spreadsheets**
 - Potential to Emit (PTE) – Criteria Pollutants – Controlled
 - Potential to Emit (PTE) – Hazardous Air Pollutants (HAP) – Controlled
 - Potential to Emit (PTE) – Greenhouse Gases (GHG) – Controlled
 - Potential to Emit (PTE) – Criteria Pollutants – PRE-Controlled
 - Potential to Emit (PTE) – Hazardous Air Pollutants (HAP) – PRE-Controlled
 - Potential to Emit (PTE) – Greenhouse Gases (GHG) – PRE-Controlled

 - **Unit-Specific Emission Spreadsheets**
 - Compressor Engine (CE-01 thru CE-12) Emissions
 - Compressor Rod Packing (CRP) Emissions
 - Generator Engine (GEN) Emissions
 - Dehydrator (DHY-01 thru DHY-03) Emissions
 - Reboiler (BLR-01 thru BLR-03) Emissions
 - Heater Treater (HTR-01 and HTR-02) Emissions
 - Stabilized Condensate - Storage Tank (TK-01 thru TK-08) Emissions
 - Produced Water - Storage Tank (WTK-01 and WTK-02) Emissions
 - Stabilized Condensate (SC) - Truck Load-Out (TLO) Emissions
 - Produced Water (PW) - Truck Load-Out (WTLO) Emissions
 - Compressor Blowdown (CBD) / Emergency Shutdown (ESD) Emissions
 - Pigging Operation (PIG) Emissions

 - **Fugitive Emissions**
 - Process Piping and Equipment Leak (FUG-G) Emissions – Gas
 - Process Piping and Equipment Leak (FUG-O) Emissions – Light Liquid
 - Engine Crankcase (ECC) Emissions
-

Appalachia Midstream Services, LLC (AMS)
Battle Run Compressor Station (BRCS)
 Application for 45CSR13 New Source Review Permit Modification (NSR)

Criteria Pollutants - Controlled

Unit ID	Point ID	Source ID	Description	Site Rating	NOX		CO		VOC (w/HCHO)		PM10/2.5		SO2	
					lb/hr*	tpy	lb/hr*	tpy	lb/hr*	tpy	lb/hr*	tpy	lb/hr*	tpy
Battle Run Compressor Station (BRCS) - Point Sources														
EUCE-1	EPCE-1	CE-01	Compressor Engine 01 - CAT G3516B (OxCat)	1,380 bhp	1.52	6.66	1.41	6.20	0.77	3.38	0.11	0.49	0.01	0.03
EUCE-2	EPCE-2	CE-02	Compressor Engine 02 - CAT G3516B (OxCat)	1,380 bhp	1.52	6.66	1.41	6.20	0.77	3.38	0.11	0.49	0.01	0.03
EUCE-3	EPCE-3	CE-03	Compressor Engine 03 - CAT G3516B (OxCat)	1,380 bhp	1.52	6.66	1.41	6.20	0.77	3.38	0.11	0.49	0.01	0.03
EUCE-4	EPCE-4	CE-04	Compressor Engine 04 - CAT G3516B (OxCat)	1,380 bhp	1.52	6.66	1.41	6.20	0.77	3.38	0.11	0.49	0.01	0.03
EUCE-5	EPCE-5	CE-05	Compressor Engine 05 - CAT G3516B (OxCat)	1,380 bhp	1.52	6.66	1.41	6.20	0.77	3.38	0.11	0.49	0.01	0.03
EUCE-6	EPCE-6	CE-06	Compressor Engine 06 - CAT G3516B (OxCat)	1,380 bhp	1.52	6.66	1.41	6.20	0.77	3.38	0.11	0.49	0.01	0.03
EUCE-7	EPCE-7	CE-07	Compressor Engine 07 - CAT G3516B (OxCat)	1,380 bhp	1.52	6.66	1.41	6.20	0.77	3.38	0.11	0.49	0.01	0.03
EUCE-8	EPCE-8	CE-08	Compressor Engine 08 - CAT G3516B (OxCat)	1,380 bhp	1.52	6.66	1.41	6.20	0.77	3.38	0.11	0.49	0.01	0.03
EUCE-9	EPCE-9	CE-09	Compressor Engine 09 - CAT G3516B (OxCat)	1,380 bhp	1.52	6.66	1.41	6.20	0.77	3.38	0.11	0.49	0.01	0.03
EUCE-10	EPCE-10	CE-10	Compressor Engine 10 - CAT G3516B (OxCat)	1,380 bhp	1.52	6.66	1.41	6.20	0.77	3.38	0.11	0.49	0.01	0.03
EUCE-11	EPCE-11	CE-11	Compressor Engine 11 - CAT G3516B (OxCat)	1,380 bhp	1.52	6.66	1.41	6.20	0.77	3.38	0.11	0.49	0.01	0.03
EUCE-12	EPCE-12	CE-12	Compressor Engine 12 - CAT G3516B (OxCat)	1,380 bhp	1.52	6.66	1.41	6.20	0.77	3.38	0.11	0.49	0.01	0.03
EUCRP	EPCRP	CRP	Compressor Rod Packing	12 Units	---	---	---	---	10.73	47.00	---	---	---	---
EUGEN-2	EPGEN-2	GEN	Generator Engine - Baldor IGLC420-2N (NSCR)	605 bhp	1.33	5.84	2.67	11.68	1.05	4.60	0.09	0.39	3E-03	0.01
EUDHY-1	EPSTL-1	DHY-01	Dehydrator 01 (BTEX Buster)	55.0 MMscfd	---	---	---	---	1.89	8.29	---	---	---	---
EUDHY-2	EPSTL-2	DHY-02	Dehydrator 02 (BTEX Buster)	55.0 MMscfd	---	---	---	---	1.89	8.29	---	---	---	---
EUDHY-3	EPSTL-3	DHY-03	Dehydrator 03 (BTEX Buster)	55.0 MMscfd	---	---	---	---	1.89	8.29	---	---	---	---
EURBL-1	EPRBL-1	BLR-01	Reboiler 01	1.00 MMBtu/hr	0.10	0.43	0.08	0.36	0.01	0.02	0.01	0.03	6E-04	3E-03
EURBL-2	EPRBL-2	BLR-02	Reboiler 02	1.00 MMBtu/hr	0.10	0.43	0.08	0.36	0.01	0.02	0.01	0.03	6E-04	3E-03
EURBL-3	EPRBL-3	BLR-03	Reboiler 03	1.00 MMBtu/hr	0.10	0.43	0.08	0.36	0.01	0.02	0.01	0.03	6E-04	3E-03
EUHT-1	EPHT-1	HTR-01	Heater-Treater Burner 01	0.50 MMBtu/hr	0.06	0.21	0.05	0.18	3E-03	0.01	5E-03	0.02	4E-04	1E-03
EUHT-2	EPHT-2	HTR-02	Heater-Treater Burner 02	0.50 MMBtu/hr	0.06	0.21	0.05	0.18	3E-03	0.01	5E-03	0.02	4E-04	1E-03
EUTK-1	EPTK-1	TK-01	Storage Tank 01 - Stabilized Condensate (SC) (VRU)	400 bbl	---	---	---	---	0.04	0.17	---	---	---	---
EUTK-2	EPTK-2	TK-02	Storage Tank 02 - Stabilized Condensate (SC) (VRU)	400 bbl	---	---	---	---	0.04	0.17	---	---	---	---
EUTK-3	EPTK-3	TK-03	Storage Tank 03 - Stabilized Condensate (SC) (VRU)	400 bbl	---	---	---	---	0.04	0.17	---	---	---	---
EUTK-4	EPTK-4	TK-04	Storage Tank 04 - Stabilized Condensate (SC) (VRU)	400 bbl	---	---	---	---	0.04	0.17	---	---	---	---
EUTK-5	EPTK-5	TK-05	Storage Tank 05 - Stabilized Condensate (SC) (VRU)	400 bbl	---	---	---	---	0.04	0.17	---	---	---	---
EUTK-6	EPTK-6	TK-06	Storage Tank 06 - Stabilized Condensate (SC) (VRU)	400 bbl	---	---	---	---	0.04	0.17	---	---	---	---
EUTK-7	EPTK-7	TK-07	Storage Tank 07 - Stabilized Condensate (SC) (VRU)	400 bbl	---	---	---	---	0.04	0.17	---	---	---	---
EUTK-8	EPTK-8	TK-08	Storage Tank 08 - Stabilized Condensate (SC) (VRU)	400 bbl	---	---	---	---	0.04	0.17	---	---	---	---
EUWTK-9	EPWTK-9	WTK-01	Storage Tank W01 - Produced Water (PW)	400 bbl	---	---	---	---	0.01	0.03	---	---	---	---
EUWTK-10	EPWTK-10	WTK-02	Storage Tank W02 - Produced Water (PW)	400 bbl	---	---	---	---	0.01	0.03	---	---	---	---
EULOAD-1	EPLOAD-1	TLO	Truck Loading - Stabilized Condensate (SC) (CarbCan)	9,965 Mgal/yr	---	---	---	---	11.97	8.52	---	---	---	---
EULOAD-2	EPLOAD-2	WTLO	Truck Loading - Produced Water (PW)	1,533 Mgal/yr	---	---	---	---	0.72	0.08	---	---	---	---
EUBD	EPBD	CBD/ESD	Compressor Blowdown/Emergency Shutdown Tests	1,249 events/yr	---	---	---	---	30.78	27.11	---	---	---	---
EUPIG	EPPIG	PIG	Pigging Operations	104 Events/yr	---	---	---	---	131.75	4.12	---	---	---	---
Battle Run Compressor Station (BRCS) - Point Sources					20.00	87.51	19.99	87.48	202.29	158.43	1.47	6.41	0.08	0.37
Battle Run Compressor Station (BRCS) - Fugitives														
EUFUG	EPFUG	FUG-G	Piping & Equip Leaks - Gas	7,472 Units	---	---	---	---	4.93	21.61	---	---	---	---
		FUG-O	Piping & Equip Leaks - Light Liquid	3,407 Units	---	---	---	---	7.46	32.68	---	---	---	---
EUECC	EPECC	ECC	Engine Crankcase Fugitives	17,165 bhp	0.05	0.21	0.29	1.28	0.14	0.60	3E-03	0.02	2E-04	9E-04
Battle Run Compressor Station (BRCS) - Fugitives					0.05	0.21	0.29	1.28	12.53	54.88	3E-03	0.02	2E-04	9E-04
Battle Run Compressor Station (BRCS) - Total														
Battle Run Compressor Station (BRCS) - Total					20.05	87.72	20.28	88.76	214.82	213.31	1.47	6.43	0.08	0.37

* = lb/hr is based on 8,760 hr/yr, except Compressor Blowdowns (CBD/ESD), Truck Load-Out (TLO, WTLO), and Pigging (PIG) are less frequent.

Appalachia Midstream Services, LLC (AMS)
Battle Run Compressor Station (BRCS)
 Application for 45CSR13 New Source Review Permit Modification (NSR)

Greenhouse Gas (GHG) Pollutants - Controlled

Source ID	Description	Site Rating	Heat Input MMBtu/hr (HHV)	Hours of Operation hr/yr*	CO2		CH4		N2O		TOTAL CO2e	
					GWP: tpy	CO2e 1 tpy	GWP: tpy	CO2e 25 tpy	GWP: tpy	CO2e 298 tpy	lb/hr*	tpy
Battle Run Compressor Station (BRCS) - Point Sources												
CE-01	Compressor Engine 01 - CAT G3516B (OxCat)	1,380 bhp	11.23	8,760	7,023	7,023	61.49	1,537	0.01	3.23	1,955	8,563
CE-02	Compressor Engine 02 - CAT G3516B (OxCat)	1,380 bhp	11.23	8,760	7,023	7,023	61.49	1,537	0.01	3.23	1,955	8,563
CE-03	Compressor Engine 03 - CAT G3516B (OxCat)	1,380 bhp	11.23	8,760	7,023	7,023	61.49	1,537	0.01	3.23	1,955	8,563
CE-04	Compressor Engine 04 - CAT G3516B (OxCat)	1,380 bhp	11.23	8,760	7,023	7,023	61.49	1,537	0.01	3.23	1,955	8,563
CE-05	Compressor Engine 05 - CAT G3516B (OxCat)	1,380 bhp	11.23	8,760	7,023	7,023	61.49	1,537	0.01	3.23	1,955	8,563
CE-06	Compressor Engine 06 - CAT G3516B (OxCat)	1,380 bhp	11.23	8,760	7,023	7,023	61.49	1,537	0.01	3.23	1,955	8,563
CE-07	Compressor Engine 07 - CAT G3516B (OxCat)	1,380 bhp	11.23	8,760	7,023	7,023	61.49	1,537	0.01	3.23	1,955	8,563
CE-08	Compressor Engine 08 - CAT G3516B (OxCat)	1,380 bhp	11.23	8,760	7,023	7,023	61.49	1,537	0.01	3.23	1,955	8,563
CE-09	Compressor Engine 09 - CAT G3516B (OxCat)	1,380 bhp	11.23	8,760	7,023	7,023	61.49	1,537	0.01	3.23	1,955	8,563
CE-10	Compressor Engine 10 - CAT G3516B (OxCat)	1,380 bhp	11.23	8,760	7,023	7,023	61.49	1,537	0.01	3.23	1,955	8,563
CE-11	Compressor Engine 11 - CAT G3516B (OxCat)	1,380 bhp	11.23	8,760	7,023	7,023	61.49	1,537	0.01	3.23	1,955	8,563
CE-12	Compressor Engine 12 - CAT G3516B (OxCat)	1,380 bhp	11.23	8,760	7,023	7,023	61.49	1,537	0.01	3.23	1,955	8,563
CRP	Compressor Rod Packing	12 Units	---	8,760	0.44	0.44	97.77	2,444	---	---	558	2,445
GEN	Generator Engine - Baldor IGLC420-2N (NSCR)	605 bhp	4.53	8,760	2,183	2,183	4.56	114	4E-03	1.30	525	2,298
DHY-01	Dehydrator 01 (BTEX Buster)	55.0 MMscfd	---	8,760	2.64	2.64	0.37	9.36	---	---	2.74	12.00
DHY-02	Dehydrator 02 (BTEX Buster)	55.0 MMscfd	---	8,760	2.64	2.64	0.37	9.36	---	---	2.74	12.00
DHY-03	Dehydrator 03 (BTEX Buster)	55.0 MMscfd	---	8,760	2.64	2.64	0.37	9.36	---	---	2.74	12.00
BLR-01	Reboiler 01	1.00 MMBtu/hr	1.00	8,760	515	515	0.01	0.25	0.01	2.82	118	518
BLR-02	Reboiler 02	1.00 MMBtu/hr	1.00	8,760	515	515	0.01	0.25	0.01	2.82	118	518
BLR-03	Reboiler 03	1.00 MMBtu/hr	1.00	8,760	515	515	0.01	0.25	0.01	2.82	118	518
HTR-01	Heater-Treater Burner 01	0.50 MMBtu/hr	0.50	8,760	258	258	5E-03	0.12	5E-03	1.41	59.17	259
HTR-02	Heater-Treater Burner 02	0.50 MMBtu/hr	0.50	8,760	258	258	5E-03	0.12	5E-03	1.41	59.17	259
TK-01	Storage Tank 01 - Stabilized Condensate (SC) (VRU)	There are De Minimis GHGs in Stabilized Condensate (SC) Storage Tank Emissions										
TK-02	Storage Tank 02 - Stabilized Condensate (SC) (VRU)											
TK-03	Storage Tank 03 - Stabilized Condensate (SC) (VRU)											
TK-04	Storage Tank 04 - Stabilized Condensate (SC) (VRU)											
TK-05	Storage Tank 05 - Stabilized Condensate (SC) (VRU)											
TK-06	Storage Tank 06 - Stabilized Condensate (SC) (VRU)											
TK-07	Storage Tank 07 - Stabilized Condensate (SC) (VRU)											
TK-08	Storage Tank 08 - Stabilized Condensate (SC) (VRU)											
WTK-01	Storage Tank W01 - Produced Water (PW)	There are De Minimis GHGs in Produced Water (PW) Storage Tank Emissions										
WTK-02	Storage Tank W02 - Produced Water (PW)											
TLO	Truck Loading - Produced Water (PW)	There are De Minimis GHGs in Stabilized Condensate (SC) Truck Loading Emissions										
WTLO	Truck Loading - Stabilized Condensate (SC) (CarbCan)											
There are De Minimis GHGs in Produce Water (PW) Truck Loading Emissions												
CBD/ESD	Compressor Blowdown/Emergency Shutdown Tests	1,249 events/yr	---	8,760	0.25	0.25	56.40	1,410	---	---	322	1,410
PIG	Pigging Operations	104 Events/yr	---	8,760	0.04	0.04	8.57	214	---	---	49	214
Battle Run Compressor Station (BRCS) - Point Sources					88,524	88,524	906	22,658	0.17	51.34	25,396	111,233
Battle Run Compressor Station (BRCS) - Fugitives												
FUG-G	Piping & Equip Leaks - Gas	7,472 Units	---	8,760	0.20	0.20	44.94	1,124	---	---	257	1,124
FUG-O	Piping & Equip Leaks - Light Liquid	There are De Minimis GHGs in Light Liquid Piping & Equip Leak Emissions										
ECC	Engine Crankcase Fugitives											
Battle Run Compressor Station (BRCS) - Fugitives					218	218	46.85	1,171	3E-04	0.10	317	1,389
Battle Run Compressor Station (BRCS) - Total												
Battle Run Compressor Station (BRCS) - Total					88,742	88,742	953	23,829	0.17	51.44	25,713	112,622

* = lb/hr is based on 8,760 hr/yr, except Compressor Blowdowns (CBD/ESD), Truck Load-Out (TLO, WTLO), and Pigging (PIG) are less frequent.

Appalachia Midstream Services, LLC (AMS)
Battle Run Compressor Station (BRCS)
 Application for 45CSR13 New Source Review Permit Modification (NSR)

Criteria Pollutants - PRE-Control

Unit ID	Point ID	Source ID	Description	Site Rating	NOX		CO		VOC (w/HCHO)		PM10/2.5		SO2	
					lb/hr*	tpy	lb/hr*	tpy	lb/hr*	tpy	lb/hr*	tpy	lb/hr*	tpy
Battle Run Compressor Station (BRCS) - Point Sources - PRE-Control														
EUCE-1	EPCE-1	CE-01	Compressor Engine 01 - CAT G3516B (OxCat)	1,380 bhp	1.52	6.66	9.43	41.31	4.41	19.32	0.11	0.49	0.01	0.03
EUCE-2	EPCE-2	CE-02	Compressor Engine 02 - CAT G3516B (OxCat)	1,380 bhp	1.52	6.66	9.43	41.31	4.41	19.32	0.11	0.49	0.01	0.03
EUCE-3	EPCE-3	CE-03	Compressor Engine 03 - CAT G3516B (OxCat)	1,380 bhp	1.52	6.66	9.43	41.31	4.41	19.32	0.11	0.49	0.01	0.03
EUCE-4	EPCE-4	CE-04	Compressor Engine 04 - CAT G3516B (OxCat)	1,380 bhp	1.52	6.66	9.43	41.31	4.41	19.32	0.11	0.49	0.01	0.03
EUCE-5	EPCE-5	CE-05	Compressor Engine 05 - CAT G3516B (OxCat)	1,380 bhp	1.52	6.66	9.43	41.31	4.41	19.32	0.11	0.49	0.01	0.03
EUCE-6	EPCE-6	CE-06	Compressor Engine 06 - CAT G3516B (OxCat)	1,380 bhp	1.52	6.66	9.43	41.31	4.41	19.32	0.11	0.49	0.01	0.03
EUCE-7	EPCE-7	CE-07	Compressor Engine 07 - CAT G3516B (OxCat)	1,380 bhp	1.52	6.66	9.43	41.31	4.41	19.32	0.11	0.49	0.01	0.03
EUCE-8	EPCE-8	CE-08	Compressor Engine 08 - CAT G3516B (OxCat)	1,380 bhp	1.52	6.66	9.43	41.31	4.41	19.32	0.11	0.49	0.01	0.03
EUCE-9	EPCE-9	CE-09	Compressor Engine 09 - CAT G3516B (OxCat)	1,380 bhp	1.52	6.66	9.43	41.31	4.41	19.32	0.11	0.49	0.01	0.03
EUCE-10	EPCE-10	CE-10	Compressor Engine 10 - CAT G3516B (OxCat)	1,380 bhp	1.52	6.66	9.43	41.31	4.41	19.32	0.11	0.49	0.01	0.03
EUCE-11	EPCE-11	CE-11	Compressor Engine 11 - CAT G3516B (OxCat)	1,380 bhp	1.52	6.66	9.43	41.31	4.41	19.32	0.11	0.49	0.01	0.03
EUCE-12	EPCE-12	CE-12	Compressor Engine 12 - CAT G3516B (OxCat)	1,380 bhp	1.52	6.66	9.43	41.31	4.41	19.32	0.11	0.49	0.01	0.03
EU CRP	EPCR	CRP	Compressor Rod Packing	12 Units	---	---	---	---	10.73	47.00	---	---	---	---
EUGEN-2	EPGEN-2	GEN	Generator Engine - Baldor IGLC420-2N (NSCR)	605 bhp	10.01	43.85	16.85	73.81	1.05	4.60	0.09	0.39	3E-03	0.01
EUDHY-1	EPSTL-1	DHY-01	Dehydrator 01 (BTEX Buster)	55.0 MMscfd	---	---	---	---	49.21	216	---	---	---	---
EUDHY-2	EPSTL-2	DHY-02	Dehydrator 02 (BTEX Buster)	55.0 MMscfd	---	---	---	---	49.21	216	---	---	---	---
EUDHY-3	EPSTL-3	DHY-03	Dehydrator 03 (BTEX Buster)	55.0 MMscfd	---	---	---	---	49.21	216	---	---	---	---
EURBL-1	EPRBL-1	BLR-01	Reboiler 01	1.00 MMBtu/hr	0.10	0.43	0.08	0.36	0.01	0.02	0.01	0.03	6E-04	3E-03
EURBL-2	EPRBL-2	BLR-02	Reboiler 02	1.00 MMBtu/hr	0.10	0.43	0.08	0.36	0.01	0.02	0.01	0.03	6E-04	3E-03
EURBL-3	EPRBL-3	BLR-03	Reboiler 03	1.00 MMBtu/hr	0.10	0.43	0.08	0.36	0.01	0.02	0.01	0.03	6E-04	3E-03
EUHT-1	EPHT-1	HTR-01	Heater-Treater Burner 01	0.50 MMBtu/hr	0.06	0.21	0.05	0.18	3E-03	0.01	5E-03	0.02	4E-04	1E-03
EUHT-2	EPHT-2	HTR-02	Heater-Treater Burner 02	0.50 MMBtu/hr	0.06	0.21	0.05	0.18	3E-03	0.01	5E-03	0.02	4E-04	1E-03
EUTK-1	EPTK-1	TK-01	Storage Tank 01 - Stabilized Condensate (SC) (VRU)	400 bbl	---	---	---	---	0.77	3.37	---	---	---	---
EUTK-2	EPTK-2	TK-02	Storage Tank 02 - Stabilized Condensate (SC) (VRU)	400 bbl	---	---	---	---	0.77	3.37	---	---	---	---
EUTK-3	EPTK-3	TK-03	Storage Tank 03 - Stabilized Condensate (SC) (VRU)	400 bbl	---	---	---	---	0.77	3.37	---	---	---	---
EUTK-4	EPTK-4	TK-04	Storage Tank 04 - Stabilized Condensate (SC) (VRU)	400 bbl	---	---	---	---	0.77	3.37	---	---	---	---
EUTK-5	EPTK-5	TK-05	Storage Tank 05 - Stabilized Condensate (SC) (VRU)	400 bbl	---	---	---	---	0.77	3.37	---	---	---	---
EUTK-6	EPTK-6	TK-06	Storage Tank 06 - Stabilized Condensate (SC) (VRU)	400 bbl	---	---	---	---	0.77	3.37	---	---	---	---
EUTK-7	EPTK-7	TK-07	Storage Tank 07 - Stabilized Condensate (SC) (VRU)	400 bbl	---	---	---	---	0.77	3.37	---	---	---	---
EUTK-8	EPTK-8	TK-08	Storage Tank 08 - Stabilized Condensate (SC) (VRU)	400 bbl	---	---	---	---	0.77	3.37	---	---	---	---
EUWTK-9	EPWTK-9	WTK-01	Storage Tank W01 - Produced Water (PW)	400 bbl	---	---	---	---	0.01	0.03	---	---	---	---
EUWTK-10	EPWTK-10	WTK-02	Storage Tank W02 - Produced Water (PW)	400 bbl	---	---	---	---	0.01	0.03	---	---	---	---
EULOAD-1	ELOAD-1	TLO	Truck Loading - Produced Water (PW)	9,965 Mgal/yr	---	---	---	---	35.72	25.43	---	---	---	---
EULOAD-2	ELOAD-2	WTLO	Truck Loading - Stabilized Condensate (SC) (CarbCan)	1,533 Mgal/yr	---	---	---	---	0.72	0.08	---	---	---	---
EU BD	EPBD	CB/ESD	Compressor Blowdown/Emergency Shutdown Tests	1,249 events/yr	---	---	---	---	6.19	27.11	---	---	---	---
EU PIG	EPPIG	PIG	Pigging Operations	104 Events/yr	---	---	---	---	131.75	4.12	---	---	---	---
Battle Run Compressor Station (BRCS) - Point Sources - PRE-Control					28.68	126	130	571	393	1,014	1.47	6.41	0.08	0.37
Battle Run Compressor Station (BRCS) - Fugitives - PRE-Control														
EUFUG	EPFUG	FUG-G	Piping & Equip Leaks - Gas	7,472 Units	---	---	---	---	4.93	21.61	---	---	---	---
		FUG-O	Piping & Equip Leaks - Light Liquid	3,407 Units	---	---	---	---	7.46	32.68	---	---	---	---
EU EEC	EP EEC	ECC	Engine Crankcase Fugitives	17,165 bhp	0.05	0.21	0.29	1.28	0.14	0.60	3E-03	0.02	2E-04	9E-04
Battle Run Compressor Station (BRCS) - Fugitives - PRE-Control					0.05	0.21	0.29	1.28	12.53	54.88	3E-03	0.02	2E-04	9E-04
Battle Run Compressor Station (BRCS) - Total - PRE-Control														
Battle Run Compressor Station (BRCS) - Total - PRE-Control					28.73	126	131	572	405	1,069	1.47	6.43	0.08	0.37

* = lb/hr is based on 8,760 hr/yr, except Compressor Blowdowns (CB/ESD), Truck Load-Out (TLO, WTLO), and Pigging (PIG) are less frequent.

Appalachia Midstream Services, LLC (AMS)
Battle Run Compressor Station (BRCS)
 Application for 45CSR13 New Source Review Permit Modification (NSR)

Greenhouse Gas (GHG) Pollutants - PRE-Control

Source ID	Description	Site Rating	Heat Input MMBtu/hr (HHV)	Hours of Operation hr/yr*	CO2	CO2e	CH4	CO2e	N2O	CO2e	TOTAL	
					GWP: 1 tpy	1 tpy	GWP: 25 tpy	25 tpy	GWP: 298 tpy	298 tpy	lb/hr*	tpy
Battle Run Compressor Station (BRCS) - Point Sources - PRE-Control												
CE-01	Compressor Engine 01 - CAT G3516B (OxCat)	1,380 bhp	11.23	8,760	7,023	7,023	61.49	1,537	0.01	3.23	1,955	8,563
CE-02	Compressor Engine 02 - CAT G3516B (OxCat)	1,380 bhp	11.23	8,760	7,023	7,023	61.49	1,537	0.01	3.23	1,955	8,563
CE-03	Compressor Engine 03 - CAT G3516B (OxCat)	1,380 bhp	11.23	8,760	7,023	7,023	61.49	1,537	0.01	3.23	1,955	8,563
CE-04	Compressor Engine 04 - CAT G3516B (OxCat)	1,380 bhp	11.23	8,760	7,023	7,023	61.49	1,537	0.01	3.23	1,955	8,563
CE-05	Compressor Engine 05 - CAT G3516B (OxCat)	1,380 bhp	11.23	8,760	7,023	7,023	61.49	1,537	0.01	3.23	1,955	8,563
CE-06	Compressor Engine 06 - CAT G3516B (OxCat)	1,380 bhp	11.23	8,760	7,023	7,023	61.49	1,537	0.01	3.23	1,955	8,563
CE-07	Compressor Engine 07 - CAT G3516B (OxCat)	1,380 bhp	11.23	8,760	7,023	7,023	61.49	1,537	0.01	3.23	1,955	8,563
CE-08	Compressor Engine 08 - CAT G3516B (OxCat)	1,380 bhp	11.23	8,760	7,023	7,023	61.49	1,537	0.01	3.23	1,955	8,563
CE-09	Compressor Engine 09 - CAT G3516B (OxCat)	1,380 bhp	11.23	8,760	7,023	7,023	61.49	1,537	0.01	3.23	1,955	8,563
CE-10	Compressor Engine 10 - CAT G3516B (OxCat)	1,380 bhp	11.23	8,760	7,023	7,023	61.49	1,537	0.01	3.23	1,955	8,563
CE-11	Compressor Engine 11 - CAT G3516B (OxCat)	1,380 bhp	11.23	8,760	7,023	7,023	61.49	1,537	0.01	3.23	1,955	8,563
CE-12	Compressor Engine 12 - CAT G3516B (OxCat)	1,380 bhp	11.23	8,760	7,023	7,023	61.49	1,537	0.01	3.23	1,955	8,563
CRP	Compressor Rod Packing	12 Units	---	8,760	0.44	0.44	97.77	2,444	---	---	558	2,445
GEN	Generator Engine - Baldor IGLC420-2N (NSCR)	605 bhp	4.53	112	2,183	2,183	4.56	114.09	4E-03	1.30	41,221	2,298
DHY-01	Dehydrator 01 (BTEX Buster)	55.0 MMscfd	---	8,760	2.64	2.64	7.49	187	---	---	43.36	190
DHY-02	Dehydrator 02 (BTEX Buster)	55.0 MMscfd	---	8,760	2.64	2.64	7.49	187	---	---	43.36	190
DHY-03	Dehydrator 03 (BTEX Buster)	55.0 MMscfd	---	8,760	2.64	2.64	7.49	187	---	---	43.36	190
BLR-01	Reboiler 01	1.00 MMBtu/hr	1.00	8,760	515	515	0.01	0.25	0.01	2.82	118	518
BLR-02	Reboiler 02	1.00 MMBtu/hr	1.00	8,760	515	515	0.01	0.25	0.01	2.82	118	518
BLR-03	Reboiler 03	1.00 MMBtu/hr	1.00	8,760	515	515	0.01	0.25	0.01	2.82	118	518
HTR-01	Heater-Treater Burner 01	0.50 MMBtu/hr	0.50	8,760	258	258	5E-03	0.12	5E-03	1.41	59.17	259
HTR-02	Heater-Treater Burner 02	0.50 MMBtu/hr	0.50	8,760	258	258	5E-03	0.12	5E-03	1.41	59.17	259
TK-01	Storage Tank 01 - Stabilized Condensate (SC) (VRU)	There are De Minimis GHGs in Stabilized Condensate (SC) Storage Tank Emissions										
TK-02	Storage Tank 02 - Stabilized Condensate (SC) (VRU)											
TK-03	Storage Tank 03 - Stabilized Condensate (SC) (VRU)											
TK-04	Storage Tank 04 - Stabilized Condensate (SC) (VRU)											
TK-05	Storage Tank 05 - Stabilized Condensate (SC) (VRU)											
TK-06	Storage Tank 06 - Stabilized Condensate (SC) (VRU)											
TK-07	Storage Tank 07 - Stabilized Condensate (SC) (VRU)											
TK-08	Storage Tank 08 - Stabilized Condensate (SC) (VRU)											
WTK-01	Storage Tank W01 - Produced Water (PW)	There are De Minimis GHGs in Produced Water (PW) Storage Tank Emissions										
WTK-02	Storage Tank W02 - Produced Water (PW)											
TLO	Truck Loading - Produced Water (PW)	There are De Minimis GHGs in Stabilized Condensate (SC) Truck Loading Emissions										
WTLO	Truck Loading - Stabilized Condensate (SC) (CarbCan)											
There are De Minimis GHGs in Produce Water (PW) Truck Loading Emissions												
CBD/ESD	Compressor Blowdown/Emergency Shutdown Tests	1,249 events/yr	---	8,760	0.25	0.25	56.40	1,410	---	---	322	1,410
PIG	Pigging Operations	104 Events/yr	---	8,760	0.04	0.04	8.57	214	---	---	48.93	214
Battle Run Compressor Station (BRCS) - Point Sources					88,524	88,524	928	23,192	0.17	51.3	66,214	111,767
Battle Run Compressor Station (BRCS) - Fugitives - PRE-Control												
FUG-G	Piping & Equip Leaks - Gas	7,472 Units	---	8,760	0.20	0.20	44.94	1,124	---	---	257	1,124
FUG-O	Piping & Equip Leaks - Light Liquid	There are De Minimis GHGs in Light Liquid Piping & Equip Leak Emissions										
ECC	Engine Crankcase Fugitives											
Battle Run Compressor Station (BRCS) - Fugitives					218	218	46.85	1,171	3E-04	0.10	317	1,389
Battle Run Compressor Station (BRCS) - Total - PRE-Control												
Battle Run Compressor Station (BRCS) - Total					88,742	88,742	975	24,363	0.17	51.44	66,531	113,156

* = lb/hr is based on 8,760 hr/yr, except Compressor Blowdowns (CBD/ESD), Truck Load-Out (TLO, WTLO), and Pigging (PIG) are less frequent.

Appalachia Midstream Services, LLC (AMS)
Battle Run Compressor Station (BRCS)
 Application for 45CSR13 New Source Review Permit Modification (NSR)

Compressor Engine (CE-01 thru CE-12) Emissions

Source ID	Description	Reference	Pollutant	Pre-Controlled Emissions				Control Efficiency	Controlled Emissions		
				g/bhp-hr	lb/MMBtu	lb/hr	tpy		g/bhp-hr	lb/hr	tpy
CE-01 CE-02 CE-03 CE-04 CE-05 CE-06 CE-07 CE-08 CE-09 CE-10 CE-11 CE-12 (Each)	Compressor Engines 01 thru 12 (Each) (OxCat-01 thru OxCat-12)	Vendor Data	NOX	0.50	0.14	1.52	6.66	---	0.50	1.52	6.66
		Vendor Data	CO	3.10	0.84	9.43	41.31	85.0%	0.47	1.41	6.20
		Vendor Data	NMNEHC	1.04	0.28	3.16	13.86	80.0%	0.21	0.63	2.77
		Sum	VOC (w/Aldehyde)	1.45	0.39	4.41	19.32	82.5%	0.25	0.77	3.38
	Caterpillar (CAT) G3516B (4SLB)	AP-42 Table 3.2-2	PM10/2.5	3.69E-02	9.99E-03	0.11	0.49	---	0.04	0.11	0.49
		AP-42 Table 3.2-2	SO2	2.17E-03	5.88E-04	0.01	0.03	---	2E-03	0.01	0.03
		AP-42 Table 3.2-2	*Acetaldehyde	3.09E-02	8.36E-03	0.09	0.41	80.0%	0.01	0.02	0.08
		AP-42 Table 3.2-2	*Acrolein	1.90E-02	5.14E-03	0.06	0.25	80.0%	4E-03	0.01	0.05
	1,380 bhp (Each)	AP-42 Table 3.2-2	Benzene	1.62E-03	4.40E-04	5E-03	0.02	80.0%	3E-04	1E-03	4E-03
	8,760 hr/yr (Each)	AP-42 Table 3.2-2	Butadiene, 1,3-	9.86E-04	2.67E-04	3E-03	0.01	80.0%	2E-04	6E-04	3E-03
	1,400 rpm, 16 cyl	AP-42 Table 3.2-2	Ethylbenzene	1.47E-04	3.97E-05	4E-04	2E-03	80.0%	3E-05	9E-05	4E-04
	264 in3/cyl	Vendor Data	*Formaldehyde	0.36	0.10	1.10	4.80	90.0%	0.04	0.11	0.48
	1,024 Exhaust Temp (oF)	AP-42 Table 3.2-2	n-Hexane	4.10E-03	1.11E-03	0.01	0.05	80.0%	8E-04	2E-03	0.01
	9,227 Exhaust Flow (acfm)	AP-42 Table 3.2-2	Methanol	9.23E-03	2.50E-03	0.03	0.12	80.0%	2E-03	0.01	0.02
	Manufactured ≥ 07/01/10 NSPS JJJJ Affected (Each)	AP-42 Table 3.2-2	POM	1.28E-03	3.47E-04	4E-03	0.02	80.0%	3E-04	8E-04	3E-03
		AP-42 Table 3.2-2	Toluene	1.51E-03	4.08E-04	5E-03	0.02	80.0%	3E-04	9E-04	4E-03
		AP-42 Table 3.2-2	TMP, 2,2,4-	9.86E-04	2.67E-04	3E-03	0.01	80.0%	2E-04	6E-04	3E-03
		AP-42 Table 3.2-2	Xylenes	6.79E-04	1.84E-04	2E-03	0.01	80.0%	1E-04	4E-04	2E-03
	8,138 Btu/bhp-hr (HHV)	AP-42 Table 3.2-2	Other/Trace HAP	1.18E-03	3.21E-04	4E-03	0.02	80.0%	2E-04	7E-04	3E-03
	11.23 MMBtu/hr (HHV) (Each)	Sum	Total HAP	0.43	0.12	1.31	5.75	88.3%	0.05	0.15	0.67
11,010 scf/hr (Each)	Vendor Data	CO2 (GWP=1)	527	143	1,603	7,023	---	527	1,603	7,023	
96.45 MMscf/yr (Each)	AP-42 Table 3.2-2	CH4 (GWP=25)	4.61	1.25	14.04	61.49	---	4.61	14.04	61.49	
1,020 Btu/scf (HHV)	40CFR98 - Table C2	N2O (GWP=298)	8.14E-04	2.20E-04	2E-03	0.01	---	8E-04	2E-03	0.01	
	Weighted Sum	CO2e	643	174	1,955	8,563	---	643	1,955	8,563	

* = Aldehyde

Notes:

- The emissions shown are based on operation at 100% of rated load for 8,760 hr/yr. Actual load and operating hours will be less.
- As per vendor specifications, NMNEHC (non-methane/non-ethane hydrocarbons) do NOT include aldehydes. VOC is the sum of NMNEHC, Acetaldehyde, Acrolein, and Formaldehyde.
- PM10/2.5 is filterable and condensable particulate matter; including PM10 and PM2.5
- "Other/Trace HAPs" includes: CarbonTetrachloride, Chlorobenzene, Chloroform, Dichloropropene, Ethylene Dibromide, Methylene Chloride, Phenol, Propylene Oxide, Styrene, 1,1,2,2-Tetrachloroethane, 1,1,2-Trichloroethane, and Vinyl Chloride (as per AP-42).
- The fuel heating value will vary, 1,020 Btu/scf (HHV) is at the low end of the range and results in a high (conservative) fuel consumption estimate.
- Total NMNEHC, VOC, HCHO, HAP and CO2e emissions include Compressor Rod Packing (CRP), Compressor Blowdown (CBD), Engine Start-up (ESU), and Engine Crankcase (ECC) Emissions:

Description (Each Engine w/ Compressor)	NMNEHC	VOC	HCHO	Tot HAP	CO2e
Engine Operations (See Above)	2.77 tpy	3.38 tpy	0.48 tpy	0.67 tpy	8,563 tpy
Compressor Rod Packing (CRP)	3.92 tpy	3.92 tpy	---	0.13 tpy	204 tpy
Compressor Blowdown (CBD)	1.60 tpy	1.60 tpy	---	0.05 tpy	83.25 tpy
Engine Start-up (ESU)	Electric or Compressed Air Starter - No Start-up Emissions				
Engine Crankcase (ECC)	0.04 tpy	0.05 tpy	0.01 tpy	0.01 tpy	21.34 tpy
TOTAL:	8.33 tpy	8.95 tpy	0.49 tpy	0.86 tpy	8,871 tpy

- Last permit application showed CO control at 98%. To be conservative this has been reduced to 93%.
- Last permit application showed HCHO control at 95%. To be conservative this has been reduced to 90%.

Appalachia Midstream Services, LLC (AMS)
Battle Run Compressor Station (BRCS)
 Application for 45CSR13 New Source Review Permit Modification (NSR)

Compressor Rod Packing (CRP) Emissions

Source ID	Unit Description (Compressor Rod Packing)	No of Cylinders	scfh per Cylinder	Contingency	Total Fugitive Leak Rate		Control Efficiency	VOC		CO2		CH4		CO2e	
					scfh	MMscfy		16,200.00 lb/MMscf		150.00 lb/MMscf		33,700.00 lb/MMscf		CH4 GWP = 25	
								lb/hr	tpy	lb/hr	tpy	lb/hr	tpy	lb/hr	tpy
CRP	Reciprocating Compressor - 01	4	12.0	15%	55.20	0.48	na	0.89	3.92	0.01	0.04	1.86	8.15	47	204
	Reciprocating Compressor - 02	4	12.0	15%	55.20	0.48		0.89	3.92	0.01	0.04	1.86	8.15	47	204
	Reciprocating Compressor - 03	4	12.0	15%	55.20	0.48		0.89	3.92	0.01	0.04	1.86	8.15	47	204
	Reciprocating Compressor - 04	4	12.0	15%	55.20	0.48		0.89	3.92	0.01	0.04	1.86	8.15	47	204
	Reciprocating Compressor - 05	4	12.0	15%	55.20	0.48		0.89	3.92	0.01	0.04	1.86	8.15	47	204
	Reciprocating Compressor - 06	4	12.0	15%	55.20	0.48		0.89	3.92	0.01	0.04	1.86	8.15	47	204
	Reciprocating Compressor - 07	4	12.0	15%	55.20	0.48		0.89	3.92	0.01	0.04	1.86	8.15	47	204
	Reciprocating Compressor - 08	4	12.0	15%	55.20	0.48		0.89	3.92	0.01	0.04	1.86	8.15	47	204
	Reciprocating Compressor - 09	4	12.0	15%	55.20	0.48		0.89	3.92	0.01	0.04	1.86	8.15	47	204
	Reciprocating Compressor - 10	4	12.0	15%	55.20	0.48		0.89	3.92	0.01	0.04	1.86	8.15	47	204
	Reciprocating Compressor - 11	4	12.0	15%	55.20	0.48		0.89	3.92	0.01	0.04	1.86	8.15	47	204
	Reciprocating Compressor - 12	4	12.0	15%	55.20	0.48		0.89	3.92	0.01	0.04	1.86	8.15	47	204
TOTAL:								10.73	47.00	0.10	0.44	22.32	97.77	558	2,445

Source ID	Unit Description (Compressor Rod Packing)	Benzene 25.00 lb/MMscf		E-Benzene 25.00 lb/MMscf		n-Hexane 400.00 lb/MMscf		Toluene 25.00 lb/MMscf		2,2,4-TMP 25.00 lb/MMscf		Xylene 25.00 lb/MMscf		Tot HAP 525.00 lb/MMscf	
		lb/hr	tpy	lb/hr	tpy	lb/hr	tpy	lb/hr	tpy	lb/hr	tpy	lb/hr	tpy	lb/hr	tpy
		CRP	Reciprocating Compressor - 01	1E-03	0.01	1E-03	0.01	0.02	0.10	1E-03	0.01	1E-03	0.01	1E-03	0.01
Reciprocating Compressor - 02	1E-03		0.01	1E-03	0.01	0.02	0.10	1E-03	0.01	1E-03	0.01	1E-03	0.01	0.03	0.13
Reciprocating Compressor - 03	1E-03		0.01	1E-03	0.01	0.02	0.10	1E-03	0.01	1E-03	0.01	1E-03	0.01	0.03	0.13
Reciprocating Compressor - 04	1E-03		0.01	1E-03	0.01	0.02	0.10	1E-03	0.01	1E-03	0.01	1E-03	0.01	0.03	0.13
Reciprocating Compressor - 05	1E-03		0.01	1E-03	0.01	0.02	0.10	1E-03	0.01	1E-03	0.01	1E-03	0.01	0.03	0.13
Reciprocating Compressor - 06	1E-03		0.01	1E-03	0.01	0.02	0.10	1E-03	0.01	1E-03	0.01	1E-03	0.01	0.03	0.13
Reciprocating Compressor - 07	1E-03		0.01	1E-03	0.01	0.02	0.10	1E-03	0.01	1E-03	0.01	1E-03	0.01	0.03	0.13
Reciprocating Compressor - 08	1E-03		0.01	1E-03	0.01	0.02	0.10	1E-03	0.01	1E-03	0.01	1E-03	0.01	0.03	0.13
Reciprocating Compressor - 09	1E-03		0.01	1E-03	0.01	0.02	0.10	1E-03	0.01	1E-03	0.01	1E-03	0.01	0.03	0.13
Reciprocating Compressor - 10	1E-03		0.01	1E-03	0.01	0.02	0.10	1E-03	0.01	1E-03	0.01	1E-03	0.01	0.03	0.13
Reciprocating Compressor - 11	1E-03		0.01	1E-03	0.01	0.02	0.10	1E-03	0.01	1E-03	0.01	1E-03	0.01	0.03	0.13
Reciprocating Compressor - 12	1E-03		0.01	1E-03	0.01	0.02	0.10	1E-03	0.01	1E-03	0.01	1E-03	0.01	0.03	0.13
TOTAL:		0.02	0.07	0.02	0.07	0.26	1.16	0.02	0.07	0.02	0.07	0.02	0.07	0.35	1.52

Notes: 1 - As per the manufacturer (Ariel): "Packing in new and broken-in condition will leak 5-10 scfh through the vent. This leakage rate will increase over time due to wear of the non-metallic sealing rings." The Williams' engineering department provides a conservative leak rate estimate of 12 scfh/cylinder (equal to 48 scfh/compressor). In this instance, an additional 15% contingency was added to yield 55.20 scfh/compressor.

3 - Prior permit applications did not include Compressor Rod Packing (CRP) emissions.

2 - The results of a representative **Wet Gas Analysis** were used to determine the following worst-case components (See Appendix A - Lab Data):

Pollutant	Wet Gas	Minimum Contingency: 10%		
		Worst Case	%Total	%VOC
CO2	106 lb/MMscf	150 lb/MMscf	0.23	---
Methane (CH4)	30,595 lb/MMscf	33,700 lb/MMscf	52.13	---
N2/Water/Ethane/Etc	13,359 lb/MMscf	14,600 lb/MMscf	22.58	---
VOC	14,688 lb/MMscf	16,200 lb/MMscf	25.06	100.00
TOTAL Gas	58,748 lb/MMscf	64,650 lb/MMscf	100.00	100.00

Pollutant	Wet Gas	Minimum Contingency: 10%		
		Worst Case	%Total	%VOC
Benzene	4 lb/MMscf	25 lb/MMscf	0.04	0.15
Ethylbenzene	1 lb/MMscf	25 lb/MMscf	0.04	0.15
n-Hexane	344 lb/MMscf	400 lb/MMscf	0.62	2.47
Toluene	7 lb/MMscf	25 lb/MMscf	0.04	0.15
2,2,4-TMP	5 lb/MMscf	25 lb/MMscf	0.04	0.15
Xylenes	4 lb/MMscf	25 lb/MMscf	0.04	0.15
Total HAP	365 lb/MMscf	525 lb/MMscf	0.81	3.24

Appalachia Midstream Services, LLC (AMS)
Battle Run Compressor Station (BRCS)
 Application for 45CSR13 New Source Review Permit Modification (NSR)

Generator Engine (GEN) Emissions

Source ID	Description	Reference	Pollutant	Pre-Controlled Emissions				Control Efficiency	Controlled Emissions		
				g/bhp-hr	lb/MMBtu	lb/hr	tpy		g/bhp-hr	lb/hr	tpy
GEN	Non-Emergency Generator Engine 02 (3-Way Catalyst (NSCR)) (NOTE: Rich Burn)	AP-42/NSPS JJJJ	NOX	7.51	2.21	10.01	43.85	86.7%	1.00	1.33	5.84
		AP-42/NSPS JJJJ	CO	12.63	3.72	16.85	73.81	84.2%	2.00	2.67	11.68
		NSPS JJJJ	NMNEHC	0.70	0.21	0.93	4.09	---	0.70	0.93	4.09
		SUM	VOC (w/HCHO)	0.79	0.23	1.05	4.60	---	0.79	1.05	4.60
	Baldor IGLC420-2N	AP-42 Table 3.2-3	PM10/2.5	6.59E-02	1.94E-02	0.09	0.39	---	0.07	0.09	0.39
		AP-42 Table 3.2-3	SO2	2.00E-03	5.88E-04	3E-03	0.01	---	2E-03	3E-03	0.01
	605 bhp 8,760 hr/yr 1,800 rpm, 126 cyl 112 in ³ /cyl	AP-42 Table 3.2-3	Acetaldehyde	9.48E-03	2.79E-03	0.01	0.06	---	0.01	0.01	0.06
		AP-42 Table 3.2-3	Acrolein	8.93E-03	2.63E-03	0.01	0.05	---	0.01	0.01	0.05
		AP-42 Table 3.2-3	Benzene	5.37E-03	1.58E-03	0.01	0.03	---	0.01	0.01	0.03
		AP-42 Table 3.2-3	Butadiene, 1,3-	2.25E-03	6.63E-04	3E-03	0.01	---	2E-03	3E-03	0.01
		AP-42 Table 3.2-3	Ethylbenzene	8.42E-05	2.48E-05	1E-04	5E-04	---	8E-05	1E-04	5E-04
		Permit Limit	Formaldehyde	8.80E-02	2.59E-02	0.12	0.51	---	0.09	0.12	0.51
		1,382 Exhaust Temp (oF)	AP-42 Table 3.2-3	n-Hexane	---	---	---	---	---	---	---
		2,995 Exhaust Flow (acfm)	AP-42 Table 3.2-3	Methanol	1.04E-02	3.06E-03	0.01	0.06	---	0.01	0.01
	AP-42 Table 3.2-3		POM	3.30E-04	9.71E-05	4E-04	2E-03	---	3E-04	4E-04	2E-03
	Manufactured ≥ 01/01/09 NSPS JJJJ Affected	AP-42 Table 3.2-3	Toluene	1.90E-03	5.58E-04	3E-03	0.01	---	2E-03	3E-03	0.01
		AP-42 Table 3.2-3	TMP, 2,2,4-	---	---	---	---	---	---	---	---
	AP-42 Table 3.2-3	Xylenes	6.62E-04	1.95E-04	9E-04	4E-03	---	7E-04	9E-04	4E-03	
	7,488 Btu/bhp-hr (HHV)	AP-42 Table 3.2-3	Other/Trace HAP	6.09E-04	1.79E-04	8E-04	4E-03	---	6E-04	8E-04	4E-03
	4.53 MMBtu/hr (HHV)	Sum	Total HAP	0.13	0.04	0.17	0.75	---	0.13	0.17	0.75
	4,441 scf/hr	AP-42 Table 3.2-3	CO2 (GWP=1)	373.61	110.00	498	2,183	---	374	498	2,183
	38.91 MMscf/yr	AP-42 Table 3.2-3	CH4 (GWP=25)	0.78	0.23	1.04	4.56	---	0.78	1.04	4.56
	1,020 Btu/scf (HHV)	40CFR98 - Table C2	N2O (GWP=298)	7.49E-04	2.20E-04	1E-03	4E-03	---	7E-04	1E-03	4E-03
	Weighted Sum	CO2e	393	116	525	2,298	---	393	525	2,298	

- Notes:
- The emissions shown are based on operation at 100% of rated load for 8,760 hr/yr. Actual load and operating hours will be less.
 - As per vendor specifications, NMNEHC (non-methane/non-ethane hydrocarbons) do NOT include formaldehyde. VOC is the sum of NMNEHC and Formaldehyde.
 - PM10/2.5 is filterable and condensable particulate matter; including PM10 and PM2.5
 - "Other/Trace HAPs" includes: CarbonTetrachloride, Chlorobenzene, Chloroform, Dichloropropene, 1,3-Dichloropropene, Ethylene Dibromide, Methylene Chloride, Phenol, Propylene Oxide, Styrene, 1,1,2,2-Tetrachloroethane, 1,1,2-Trichloroethane, and Vinyl Chloride (as per AP-42).
 - The fuel heating value will vary, 1,020 Btu/scf (HHV) is at the low end of the range and results in a high (conservative) fuel consumption estimate.
 - Total NMNEHC, VOC, HCHO, HAP and CO2e emissions include Compressor Rod Packing (CRP), Compressor Blowdown (CBD), Engine Start-up (ESU), and Engine Crankcase (ECC) Emissions:

Description (Each Engine w/ Compressor)	NMNEHC	VOC	HCHO	Tot HAP	CO2e
Engine Operations (See Above)	4.09 tpy	4.60 tpy	0.51 tpy	0.75 tpy	2,298 tpy
Compressor Rod Packing (CRP)	3.92 tpy	3.92 tpy	---	0.13 tpy	204 tpy
Compressor Blowdown (CBD)	1.60 tpy	1.60 tpy	---	0.05 tpy	83.25 tpy
Engine Start-up (ESU)	Electric or Compressed Air Starter - No Start-up Emissions				
Engine Crankcase (ECC)	0.04 tpy	0.05 tpy	0.01 tpy	0.01 tpy	21.34 tpy
TOTAL:	9.64 tpy	10.17 tpy	0.53 tpy	0.94 tpy	2,606 tpy

Appalachia Midstream Services, LLC (AMS)
Battle Run Compressor Station (BRCS)
 Application for 45CSR13 New Source Review Permit Modification (NSR)

Dehydrator (DHY-01 thru -03) Emissions

Source ID	Description	Reference	Pollutant	Worst-Case PRE-Control Emissions		Control Efficiency %	Worst-Case Controlled Emissions	
				lb/hr	tpy		lb/hr	tpy
DHY-01 DHY-02 DHY-03 (Each)	Dehydrator 01 thru 03 (Each) (No Combustion Emissions Shown, See BLR-01 thru 03) 55.0 MMscfd (Each) 8,760 hr/yr (Each) *All the Flash-Tank Off-Gas Stream is Recycled as Fuel or otherwise reclaimed. Recycle/reclaim is <u>NOT</u> an Emissions Control Technology. 20,075 MMscf/yr (Each) 2.29 MMscf/hr (Each) NESHAP HH - Exempt (Less than 1.0 tpy Benzene)	See BLR-01 thru BLR-03	NOX			See BLR-01 thru BLR-03		
		See BLR-01 thru BLR-03	CO			See BLR-01 thru BLR-03		
		GRI-GLYCalc 4.0	NMNEHC	49.21	215.55	96.2%	1.89	8.29
		GRI-GLYCalc 4.0	VOC	49.21	215.55	96.2%	1.89	8.29
		See BLR-01 thru BLR-03	SO2			See BLR-01 thru BLR-03		
		See BLR-01 thru BLR-03	PM10/2.5			See BLR-01 thru BLR-03		
		See BLR-01 thru BLR-03	Acetaldehyde			See BLR-01 thru BLR-03		
		See BLR-01 thru BLR-03	Acrolein			See BLR-01 thru BLR-03		
		GRI-GLYCalc 4.0	Benzene	1.69	7.39	96.1%	0.07	0.29
		See BLR-01 thru BLR-03	Butadiene, 1,3-			See BLR-01 thru BLR-03		
		GRI-GLYCalc 4.0	Ethylbenzene	0.31	1.34	98.4%	5E-03	0.02
		See BLR-01 thru BLR-03	Formaldehyde			See BLR-01 thru BLR-03		
		GRI-GLYCalc 4.0	n-Hexane	2.33	10.19	95.8%	0.10	0.43
		See BLR-01 thru BLR-03	Methanol			See BLR-01 thru BLR-03		
		See BLR-01 thru BLR-03	POM			See BLR-01 thru BLR-03		
		GRI-GLYCalc 4.0	Toluene	3.38	14.79	97.2%	0.09	0.41
		GRI-GLYCalc 4.0	TMP, 2,2,4-	0.23	1.00	99.0%	2E-03	0.01
		GRI-GLYCalc 4.0	Xylenes	2.81	12.29	98.6%	0.04	0.17
		See BLR-01 thru BLR-03	Other/Trace HAP			See BLR-01 thru BLR-03		
		SUM	Total HAP	10.73	46.99	97.2%	0.30	1.34
GRI-GLYCalc 4.0	CO2 (GWP=1)	0.60	2.64	---	0.60	2.64		
GRI-GLYCalc 4.0	CH4 (GWP=25)	1.71	7.49	95.0%	0.09	0.37		
GRI-GLYCalc 4.0	N2O (GWP=298)			See BLR-01 thru BLR-03				
WEIGHTED SUM	CO2e	43.36	189.94	94%	2.74	12.00		

Notes: 1 - Results of GRI-GLYCalc Model are shown below:

55.0 MMscfd DHY-01	GRI-GLYCalc 4.0*				*Dehydrator Operating Parameters (See Supplement S6 - Emission Programs)		
	PRE-Control Emissions		Controlled Emissions		Manufacturer:	Dry Gas Flow Rate:	55.0 MMscfd
	GLYCalc Results	Worst-Case**	GLYCalc Results	Worst-Case**	Wet Gas:	Gas Analysis:	11/03/16
NMNEHC = VOC	195.957 tpy	215.55 tpy	7.539 tpy	8.29 tpy	Wet Gas: 95.00 oF	Primary Pump:	Electric
Benzene	6.719 tpy	7.39 tpy	0.265 tpy	0.29 tpy	Wet Gas: 1,100.00 psig	Backup Pump:	2xKimray 45020PV
Ethylbenzene	1.217 tpy	1.34 tpy	0.019 tpy	0.02 tpy	Wet Gas: Saturated	Glycol Circ Rate:	22.00 gpm
n-Hexane	9.260 tpy	10.19 tpy	0.393 tpy	0.43 tpy	Wet Gas: 47.68 lb-H2O/MMscf	Glycol Circ Ratio:	12.57 gal/lb-H2O
Toluene	13.443 tpy	14.79 tpy	0.371 tpy	0.41 tpy	Dry Gas: 7.00 lb H2O/MMscf	Rich Glycol:	2.30 wt% H2O
2,2,4-TMP	0.090 tpy	1.00 tpy	0.004 tpy	0.01 tpy	Lean Glycol: 1.50 wt% H2O	Regen Overhead:	2,570 scfh
Xylenes	11.172 tpy	12.29 tpy	0.157 tpy	0.17 tpy	Flash Temp: 120.00 oF	Regen Control:	Cond/Comb
Total HAP	41.901 tpy	46.99 tpy	1.208 tpy	1.34 tpy	Flash Pressure: 50.00 psig	Condenser Temp:	120.00 oF
Carbon Dioxide (CO2)	2.400 tpy	2.64 tpy	2.400 tpy	2.64 tpy	Flash Off-Gas: 1,590 scfh	Condenser Press:	14.08 psia
Methane (CH4)	6.811 tpy	7.49 tpy	0.340 tpy	0.37 tpy	Off-Gas Recycle: 100.00%	Comb Control Eff:	95.00%
					Off-Gas Control: na	Ambient Temp:	60.00 oF
					Stripping Gas: na	Condenser Vent:	363 scfh

(**Worst-Case is determined with a 110% "Safety Margin".)

- 2 - The emissions shown are based on operation at 100% of rated capacity for 8,760 hr/yr. Actual load and operating hours will be less.
- 3 - Emissions from utilization of the Kimray 45020PV Backup glycol pump (2x7.5 gpm) actually results in a reduction of hourly VOC emissions (Kimray: 0.71 lb/hr vs Electric: 1.72 lb/hr)

Appalachia Midstream Services, LLC (AMS)
Battle Run Compressor Station (BRCS)
 Application for 45CSR13 New Source Review Permit Modification (NSR)

Reboiler (BLR-01 thru -03) Emissions

Source ID	Description	Reference	Pollutant	Emission Factor		Emissions	
				lb/MMscf	lb/MMBtu	lb/hr	tpy
BLR-01 BLR-02 BLT-03 (Each)	Reboiler 01 thru 03 (Each)	EPA AP-42 Table 1.4-1	NOX	100	9.80E-02	0.10	0.43
		EPA AP-42 Table 1.4-1	CO	84	8.24E-02	0.08	0.36
		EPA AP-42 Table 1.4-2	NMNEHC	5.5	5.39E-03	0.01	0.02
		EPA AP-42 Table 1.4-2	VOC	5.5	5.39E-03	0.01	0.02
		EPA AP-42 Table 1.4-2	PM10/2.5	7.6	7.45E-03	0.01	0.03
		EPA AP-42 Table 1.4-2	SO2	0.6	5.88E-04	6E-04	3E-03
	1.00 MMBtu/hr (HHV) (Each)	EPA AP-42 Table 1.4-3	Acetaldehyde	---	---	---	---
		EPA AP-42 Table 1.4-3	Acrolein	---	---	---	---
		EPA AP-42 Table 1.4-3	Benzene	2.10E-03	2.06E-06	2E-06	9E-06
		EPA AP-42 Table 1.4-4	Butadiene, 1,3-	---	---	---	---
		EPA AP-42 Table 1.4-3	Ethylbenzene	---	---	---	---
		EPA AP-42 Table 1.4-3	Formaldehyde	7.50E-02	7.35E-05	7E-05	3E-04
	1,020 Btu/scf (HHV)	EPA AP-42 Table 1.4-3	n-Hexane	1.80	1.76E-03	2E-03	0.01
		EPA AP-42 Table 1.4-3	Methanol	---	---	---	---
		EPA AP-42 Table 1.4-3	POM	6.98E-04	6.85E-07	7E-07	3E-06
		EPA AP-42 Table 1.4-3	Toluene	3.40E-03	3.33E-06	3E-06	1E-05
		EPA AP-42 Table 1.4-3	TMP, 2,2,4-	---	---	---	---
		EPA AP-42 Table 1.4-3	Xylenes	---	---	---	---
	8,760 hr/yr (Each)	EPA AP-42 Table 1.4-3	Other/Trace HAP	1.20E-03	1.18E-06	1E-06	5E-06
		SUM	Total HAP	1.88	1.85E-03	2E-03	0.01
	980 scf/hr (Each)	EPA AP-42 Table 1.4-2	CO2 (GWP=1)	120,000	118	118	515
8.59 MMscf/yr (Each)	EPA AP-42 Table 1.4-2	CH4 (GWP=25)	2.30	2.25E-03	2E-03	0.01	
	EPA AP-42 Table 1.4-2	N2O (GWP=298)	2.20	2.16E-03	2E-03	0.01	
	WEIGHTED SUM	CO2e	120,713	118	118	518	

- Notes:
- 1 - The emissions shown are based on operation at 100% of rated load for 8,760 hr/yr. Actual load and operating hours will be less.
 - 2 - The fuel heating value will vary, 1,020 Btu/scf (HHV) is at the low end of the range and results in a high (conservative) fuel consumption estimate.
 - 3 - PM10/2.5 is filterable and condensable particulate matter; including PM10 and PM2.5
 - 4 - "Other/Trace HAPs" includes: CarbonTetrachloride, Chlorobenzene, Chloroform, Dichloropropene, 1,3-Dichloropropene, Ethylene Dibromide, Methylene Chloride, Phenol, Propylene Oxide, Styrene, 1,1,2,2-Tetrachloroethane, 1,1,2-Trichloroethane, and Vinyl Chloride (as per AP-42).

Appalachia Midstream Services, LLC (AMS)
Battle Run Compressor Station (BRCS)
 Application for 45CSR13 New Source Review Permit Modification (NSR)

Heater-Treater (HTR-01 and HTR-02) Emissions

Source ID	Description	Reference	Pollutant	Emission Factor		Emissions	
				lb/MMscf	lb/MMBtu	lb/hr	tpy
HTR-01 HTR-02	Heater-Treater 01 and 02 (Each)	EPA AP-42 Table 1.4-1	NOX	100	9.80E-02	0.06	0.21
		EPA AP-42 Table 1.4-1	CO	84	8.24E-02	0.05	0.18
		EPA AP-42 Table 1.4-2	NMNEHC	5.5	5.39E-03	3E-03	0.01
		EPA AP-42 Table 1.4-2	VOC	5.5	5.39E-03	3E-03	0.01
		EPA AP-42 Table 1.4-2	PM10/2.5	7.6	7.45E-03	5E-03	0.02
		EPA AP-42 Table 1.4-2	SO2	0.6	5.88E-04	4E-04	1E-03
	0.50 MMBtu/hr (HHV) (Each)	EPA AP-42 Table 1.4-3	Acetaldehyde	---	---	---	---
		EPA AP-42 Table 1.4-3	Acrolein	---	---	---	---
		EPA AP-42 Table 1.4-3	Benzene	2.10E-03	2.06E-06	1E-06	5E-06
		EPA AP-42 Table 1.4-4	Butadiene, 1,3-	---	---	---	---
		EPA AP-42 Table 1.4-3	Ethylbenzene	---	---	---	---
		EPA AP-42 Table 1.4-3	Formaldehyde	7.50E-02	7.35E-05	5E-05	2E-04
	1,020 Btu/scf (HHV)	EPA AP-42 Table 1.4-3	n-Hexane	1.80	1.76E-03	1E-03	4E-03
		EPA AP-42 Table 1.4-3	Methanol	---	---	---	---
		EPA AP-42 Table 1.4-3	POM	6.98E-04	6.85E-07	4E-07	1E-06
		EPA AP-42 Table 1.4-3	Toluene	3.40E-03	3.33E-06	2E-06	7E-06
		EPA AP-42 Table 1.4-3	TMP, 2,2,4-	---	---	---	---
		EPA AP-42 Table 1.4-3	Xylenes	---	---	---	---
	8,760 hr/yr (Each)	EPA AP-42 Table 1.4-3	Other/Trace HAP	1.20E-03	1.18E-06	7E-07	3E-06
		SUM	Total HAP	1.88	1.85E-03	1E-03	4E-03
	600 scf/hr (Each)	EPA AP-42 Table 1.4-2	CO2 (GWP=1)	120,000	118	72	258
		EPA AP-42 Table 1.4-2	CH4 (GWP=25)	2.30	2.25E-03	1E-03	5E-03
	4.29 MMscf/yr (Each)	EPA AP-42 Table 1.4-2	N2O (GWP=298)	2.20	2.16E-03	1E-03	5E-03
WEIGHTED SUM		CO2e	120,713	118	59	259	

- Notes:
- 1 - The emissions shown are based on operation at 100% of rated load for 8,760 hr/yr. Actual load and operating hours will be less.
 - 2 - The fuel heating value will vary, 1,020 Btu/scf (HHV) is at the low end of the range and results in a high (conservative) fuel consumption estimate. (Operator experience indicates 600 scf/hr is requisite for "cold-starts".)
 - 3 - PM10/2.5 is filterable and condensable particulate matter; including PM10 and PM2.5
 - 4 - "Other/Trace HAPs" includes: CarbonTetrachloride, Chlorobenzene, Chloroform, Dichloropropene, 1,3-Dichloropropene, Ethylene Dibromide, Methylene Chloride, Phenol, Propylene Oxide, Styrene, 1,1,2,2-Tetrachloroethane, 1,1,2-Trichloroethane, and Vinyl Chloride (as per AP-42).

Stabilized Condensate - Storage Tank (TK01 thru TK-08) Emissions

Source ID	Source ID	Material Stored	Capacity bbl	T-Put bbl/yr	PRE-CONTROL			VRU Control Efficiency	VOC (100%)		CO2 (w/o Control) --- VOC		CH4 --- VOC		CO2e CH4 GWP = 25		
					W+B	Flash	Total		lb/hr	tpy	lb/hr	tpy	lb/hr	tpy	lb/hr	tpy	
					lb/yr	lb/yr	lb/yr										
EUTK1-8	TK-01	Stabilized Condensate	400	29,656	6,741	---	6,741	0.04	0.17	---	---	---	---	---	---	---	
	TK-02	Stabilized Condensate	400	29,656	6,741	---	6,741	0.04	0.17	---	---	---	---	---	---	---	
	TK-03	Stabilized Condensate	400	29,656	6,741	---	6,741	0.04	0.17	---	---	---	---	---	---	---	
	TK-04	Stabilized Condensate	400	29,656	6,741	---	6,741	0.04	0.17	---	---	---	---	---	---	---	
	TK-05	Stabilized Condensate	400	29,656	6,741	---	6,741	0.04	0.17	---	---	---	---	---	---	---	
	TK-06	Stabilized Condensate	400	29,656	6,741	---	6,741	0.04	0.17	---	---	---	---	---	---	---	
	TK-07	Stabilized Condensate	400	29,656	6,741	---	6,741	0.04	0.17	---	---	---	---	---	---	---	
	TK-08	Stabilized Condensate	400	29,656	6,741	---	6,741	0.04	0.17	---	---	---	---	---	---	---	
TOTAL:					3,200	237,250	53,931	95%	0.31	1.35	---	---	---	---	---	---	
				Mgal/yr:	9,965			PRE-Control (Each):		0.77	3.37						
				Turnovers:	74.14			PRE-Control (Total):		6.16	26.97						

Source ID	Tank ID	Benzene 2.00% VOC		Ethylbenzene 2.00% VOC		n-Hexane 20.00% VOC		Methanol (MeOH)		Toluene 2.00% VOC		2,2,4-TMP 2.00% VOC		Xylene 2.00% VOC		Total HAP 30.00% VOC	
		lb/hr	tpy	lb/hr	tpy	lb/hr	tpy	lb/hr	tpy	lb/hr	tpy	lb/hr	tpy	lb/hr	tpy	lb/hr	tpy
EUTK1-8	TK-01	8E-04	3E-03	8E-04	3E-03	0.01	0.03	---	---	8E-04	3E-03	8E-04	3E-03	8E-04	3E-03	0.01	0.05
	TK-02	8E-04	3E-03	8E-04	3E-03	0.01	0.03	---	---	8E-04	3E-03	8E-04	3E-03	8E-04	3E-03	0.01	0.05
	TK-03	8E-04	3E-03	8E-04	3E-03	0.01	0.03	---	---	8E-04	3E-03	8E-04	3E-03	8E-04	3E-03	0.01	0.05
	TK-04	8E-04	3E-03	8E-04	3E-03	0.01	0.03	---	---	8E-04	3E-03	8E-04	3E-03	8E-04	3E-03	0.01	0.05
	TK-05	8E-04	3E-03	8E-04	3E-03	0.01	0.03	---	---	8E-04	3E-03	8E-04	3E-03	8E-04	3E-03	0.01	0.05
	TK-06	8E-04	3E-03	8E-04	3E-03	0.01	0.03	---	---	8E-04	3E-03	8E-04	3E-03	8E-04	3E-03	0.01	0.05
	TK-07	8E-04	3E-03	8E-04	3E-03	0.01	0.03	---	---	8E-04	3E-03	8E-04	3E-03	8E-04	3E-03	0.01	0.05
	TK-08	8E-04	3E-03	8E-04	3E-03	0.01	0.03	---	---	8E-04	3E-03	8E-04	3E-03	8E-04	3E-03	0.01	0.05
TOTAL:		0.01	0.03	0.01	0.03	0.06	0.27	---	---	0.01	0.03	0.01	0.03	0.01	0.03	0.09	0.40
PRE-Control (Each):		0.02	0.07	0.02	0.07	0.15	0.67	---	---	0.02	0.07	0.02	0.07	0.02	0.07	0.23	1.01
PRE-Control (Total):		0.12	0.54	0.12	0.54	1.23	5.39	---	---	0.12	0.54	0.12	0.54	0.12	0.54	1.85	8.09

Notes: 1 - EPA TANKS 4.0.9d was used to determine working and breathing losses from each (of 2) Produced Water Storage Tank - See Supplement S6 - Emission Programs.

TANKS 4.0.9d
Emissions Report - Summary Format
Individual Tank Emission Totals

Emissions Report for: Annual

Battle Run CF 400 bbl Stabilized Condensate Tank - Vertical Fixed Roof Tank
Near Dallas, West Virginia

Losses(lbs)			
Components	Working Loss	Breathing Loss	Total Emissions
Gasoline (RVP 12)	5,721.52	1,019.88	6,741.40

Appalachia Midstream Services, LLC (AMS)
Battle Run Compressor Station (BRCS)
 Application for 45CSR13 New Source Review Permit Modification (NSR)

Produced Water - Storage Tank (WTK-01 and WTK-02) Emissions

Source ID	Tank ID	Material Stored	Capacity bbl	T-Put bbl/yr	PRE-CONTROL			VRU Control Efficiency	VOC		CO2 (w/o Control) --- VOC		CH4 --- VOC		CO2e CH4 GWP = 25	
					W+B	Flash	Total		lb/hr	tpy	lb/hr	tpy	lb/hr	tpy	lb/hr	tpy
					lb/yr	lb/yr	lb/yr									
EPWTK	WTK-01	Produced Water	400	18,250	61	---	61	0.01	0.03	---	---	---	---	---	---	
	WTK-02	Produced Water	400	18,250	61	---	61	0.01	0.03	---	---	---	---	---	---	
			800	36,500	122.00			TOTAL:	0.01	0.06	---	---	---	---	---	
				Mgal/yr:	1,533	PRE-Control (Each):		0.01	0.03	---	---	---	---	---	---	
				Turnovers:	45.63	PRE-Control (Total):		0.01	0.06	---	---	---	---	---	---	

Source ID	Tank ID	Benzene 2.00% VOC		Ethylbenzene 2.00% VOC		n-Hexane 20.00% VOC		Methanol (MeOH)		Toluene 2.00% VOC		2,2,4-TMP 2.00% VOC		Xylene 2.00% VOC		Total HAP 30.00% VOC	
		lb/hr	tpy	lb/hr	tpy	lb/hr	tpy	lb/hr	tpy	lb/hr	tpy	lb/hr	tpy	lb/hr	tpy	lb/hr	tpy
EPWTK	WTK-01	1E-04	6E-04	1E-04	6E-04	1E-03	0.01	---	---	1E-04	6E-04	1E-04	6E-04	1E-04	6E-04	2E-03	0.01
	WTK-02	1E-04	6E-04	1E-04	6E-04	1E-03	0.01	---	---	1E-04	6E-04	1E-04	6E-04	1E-04	6E-04	2E-03	0.01
TOTAL:		3E-04	1E-03	3E-04	1E-03	3E-03	0.01	---	---	3E-04	1E-03	3E-04	1E-03	3E-04	1E-03	4E-03	0.02
PRE-Control (Each):		1E-04	6E-04	1E-04	6E-04	1E-03	0.01	---	---	1E-04	6E-04	1E-04	6E-04	1E-04	6E-04	2E-03	0.01
PRE-Control (Total):		3E-04	1E-03	3E-04	1E-03	3E-03	0.01	---	---	3E-04	1E-03	3E-04	1E-03	3E-04	1E-03	4E-03	0.02

Notes: 1 - EPA TANKS 4.0.9d was used to determine working and breathing losses from each (of 2) Produced Water Storage Tank - See Supplement S6 - Emission Programs.

TANKS 4.0.9d
Emissions Report - Summary Format
Individual Tank Emission Totals

Emissions Report for: Annual

Battle Run 400 bbl Produced Water Tank - Vertical Fixed Roof Tank
 Near Dallas, West Virginia

Components	Losses(lbs)		
	Working Loss	Breathing Loss	Total Emissions
Produced Water	101.51	18.57	120.08
Water	49.94	9.14	59.08
Gasoline (RVP 12)	51.57	9.44	61.00

Appalachia Midstream Services, LLC (AMS)
Battle Run Compressor Station (BRCS)
 Application for 45CSR13 New Source Review Permit Modification (NSR)

Stabilized Condensate (SC) - Truck Load-Out (TLO) Emissions

Source ID	Description	S	P	M	T	CE	L _L	T-Put	VOC		CO ₂		CH ₄		CO ₂ e	
		sat. fac.	psia	lb/lb-mol	°R	%	lb/Mgal	Mgal/yr	lb/hr	tpy	lb/hr	tpy	lb/hr	tpy	lb/hr	tpy
TLO	Truck Load-Out - SC	0.60	5.44	64.00	510	66.5%	1.71	9,965	11.97	8.52	---	---	---	---	---	---
(See Attachment D3 - EPA TANKS 4.0.9d Emission Report)								TOTAL:	11.97	8.52	---	---	---	---	---	---
								PRE-Control:	35.72	25.4	---	---	---	---	---	---

Source ID	Benzene 2.00% VOC		Ethylbenzene 2.00% VOC		n-Hexane 20.00% VOC		Methanol (MeOH)		Toluene 2.00% VOC		2,2,4-TMP 2.00% VOC		Xylene 2.00% VOC		Total HAP 30.00% VOC	
	lb/hr	tpy	lb/hr	tpy	lb/hr	tpy	lb/hr	tpy	lb/hr	tpy	lb/hr	tpy	lb/hr	tpy	lb/hr	tpy
TLO	0.24	0.17	0.24	0.17	2.39	1.70	---	---	0.24	0.17	0.24	0.17	0.24	0.17	3.59	2.56
TOTAL:	0.24	0.17	0.24	0.17	2.39	1.70	---	---	0.24	0.17	0.24	0.17	0.24	0.17	3.59	2.56
PRE-Cont:	0.71	0.51	0.71	0.51	7.14	5.09	---	---	0.71	0.51	0.71	0.51	0.71	0.51	10.72	7.63

- Notes: 1 - Emission factors and formulas are from AP-42 Section 5.2 "Transportation and Marketing of Petroleum Liquids":
 $L_L = 12.46 \times S \times P \times M / T \times (1 - CE)$
 where: L_L = loading loss, lb/1000 gal of liquid loaded
 S = saturation factor, use 0.60 for submerged fill.
 P = true vapor pressure of liquid loaded, psia.
 M = molecular weight of vapors, lb/lb-mol.
 T = temperature of bulk liquid loaded, °R = °F + 460
 CE = overall emission reduction efficiency (collection efficiency x control efficiency).
- 2 - For condensate loading, the collection efficiency is 70% for tanker trucks not subject to annual leak test.
 3 - Emissions from loading of stabilized condensate will be controlled with 95% efficient carbon canisters.
 4 - Stabilized condensate (SC) vapor pressure, molecular weight, and temperature are from EPA TANKS 4.0.9d output.
 5 - The total stabilized condensate storage tank capacity at the facility is:

3,200

 bbl =

134,400

 gal.
 6 - The maximum stabilized condensate throughput at the facility is:

237,250

 bbl/yr =

9,964,500

 gal/yr =

74.14

 t-o/yr
 7 - n-Hexane, each BTEX, and 2,2,4-TMP components are conservatively estimated at 5% of VOC emissions and Total HAP is estimated at 30% of VOC emissions.
 8 - It is assumed each tanker truck holds 7,000 gallons and can be loaded in one hour:

1,424

 hr/yr

TANKS 4.0.9d
Emissions Report - Summary Format
Liquid Contents of Storage Tank

Battle Run CF 400 bbl Stabilized Condensate Tank - Vertical Fixed Roof Tank
Near Dallas, West Virginia

Mixture/Component	Month	Daily Liquid Surf. Temperature (deg F)			Liquid Bulk Temp (deg F)	Vapor Pressure (psia)			Vapor Mol. Weight.	Liquid Mass Fract.	Vapor Mass Fract.	Mol. Weight	Basis for Vapor Pressure Calculations
		Avg.	Min.	Max.		Avg.	Min.	Max.					
Gasoline (RVP 12)	All	51.94	47.06	56.81	50.33	5.4430	4.9447	5.9807	64.0000			92.00	Option 4: RVP=12, ASTM Slope=3

Appalachia Midstream Services, LLC (AMS)
Battle Run Compressor Station (BRCS)
 Application for 45CSR13 New Source Review Permit Modification (NSR)

Produced Water (PW) - Truck Load-Out (WTLO) Emissions

Source ID	Description	S	P	M	T	CE	L _L	T-Put	VOC		CO ₂		CH ₄		CO ₂ e CH ₄ GWP = 25	
		sat. fac.	psia	lb/lb-mol	°R	%	lb/Mgal	Mgal/yr	lb/hr	tpy	lb/hr	tpy	lb/hr	tpy	lb/hr	tpy
WTLO	Truck Load-Out - PW	0.60	0.25	28.35	510	---	0.10	1,533	0.72	0.08	---	---	---	---	---	---
TOTAL:									0.72	0.08	---	---	---	---	---	

PRE-Control: 0.72 0.08 --- --- --- --- --- ---

Source ID	Benzene 2.00% VOC		Ethylbenzene 2.00% VOC		n-Hexane 20.00% VOC		Methanol (MeOH)		Toluene 2.00% VOC		2,2,4-TMP 2.00% VOC		Xylene 2.00% VOC		Total HAP 30.00% VOC	
	lb/hr	tpy	lb/hr	tpy	lb/hr	tpy	lb/hr	tpy	lb/hr	tpy	lb/hr	tpy	lb/hr	tpy	lb/hr	tpy
WTLO	0.01	2E-03	0.01	2E-03	0.14	0.02	---	---	0.01	2E-03	0.01	2E-03	0.01	2E-03	0.22	0.02
TOTAL:																

PRE-Cont: 0.01 2E-03 0.01 2E-03 0.14 0.02 --- --- 0.01 2E-03 0.01 2E-03 0.01 2E-03 0.22 0.02

Notes: 1 - Emission factors and formulas are from AP-42 Section 5.2 "Transportation and Marketing of Petroleum Liquids":

$$L_L = 12.46 \times S \times P \times M / T \times (1 - CE)$$

where:

L_L = loading loss, lb/1000 gal of liquid loaded

S = saturation factor, use 0.60 for submerged fill.

P = true vapor pressure of liquid loaded, psia.

M = molecular weight of vapors, lb/lb-mol.

T = temperature of bulk liquid loaded, °R = °F + 460

CE = overall emission reduction efficiency (collection efficiency x control efficiency).

2 - Produced water vapor pressure, molecular weight, and temperature are based on operator experience and sampling data at various locations in the Marcellus Shale basin.

3 - The total produced water storage tank capacity at the facility is:

800 bbl = 33,600 gal.

4 - The maximum produced water throughput at the facility is:

36,500 bbl/yr = 1,533,000 gal/yr = 45.63 t-o/yr

5 - n-hexane,

each RTEF

6 - It is assumed each tanker truck holds 7,000 gallons and can be loaded in one hour:

219 hr/yr

TANKS 4.0.9d
Emissions Report - Summary Format
Liquid Contents of Storage Tank

Battle Run 400 bbl Produced Water Tank - Vertical Fixed Roof Tank
 Near Dallas, West Virginia

Mixture/Component	Month	Daily Liquid Surf. Temperature (deg F)			Liquid Bulk Temp (deg F)	Vapor Pressure (psia)			Vapor Mol. Weight	Liquid Mass Fract.	Vapor Mass Fract.	Mol. Weight	Basis for Vapor Pressure Calculations
		Avg.	Min.	Max.		Avg.	Min.	Max.					
Produced Water	All	51.94	47.06	56.81	50.33	0.2465	0.2101	0.2893	28.3522	0.0500	0.5080	18.75	Option 4: RVP=12, ASTM Slope=3 Option 1: VP50 = .178073 VP60 = .255246
Gasoline (RVP 12)						5.4430	4.9447	5.9807	64.0000	0.9500	0.4920	92.00	
Water						0.1930	0.1614	0.2307	18.0000			18.00	

Compressor Blowdown (CBD) / Emergency Shutdown (ESD) Emissions

Source ID	Unit Description	Site Rating bhp	Blowdown and ESD Events/yr	Blowdown Gas scf/bhp	Total Gas Vented MMscf/yr	Control %	VOC 16,200 lb/MMscf		CO2 150 lb/MMscf		CH4 33,700 lb/MMscf		CO2e CH4 GWP = 25	
							lb/hr	tpy	lb/hr	tpy	lb/hr	tpy	lb/hr	tpy
CBD/ESD	Reciprocating Compressor - 01	1,380	104	1.38	0.20	na	30.78	1.60	0.29	0.01	64.03	3.33	1,601	83.25
	Reciprocating Compressor - 02	1,380	104	1.38	0.20		30.78	1.60	0.29	0.01	64.03	3.33	1,601	83.25
	Reciprocating Compressor - 03	1,380	104	1.38	0.20		30.78	1.60	0.29	0.01	64.03	3.33	1,601	83.25
	Reciprocating Compressor - 04	1,380	104	1.38	0.20		30.78	1.60	0.29	0.01	64.03	3.33	1,601	83.25
	Reciprocating Compressor - 05	1,380	104	1.38	0.20		30.78	1.60	0.29	0.01	64.03	3.33	1,601	83.25
	Reciprocating Compressor - 06	1,380	104	1.38	0.20		30.78	1.60	0.29	0.01	64.03	3.33	1,601	83.25
	Reciprocating Compressor - 07	1,380	104	1.38	0.20		30.78	1.60	0.29	0.01	64.03	3.33	1,601	83.25
	Reciprocating Compressor - 08	1,380	104	1.38	0.20		30.78	1.60	0.29	0.01	64.03	3.33	1,601	83.25
	Reciprocating Compressor - 09	1,380	104	1.38	0.20		30.78	1.60	0.29	0.01	64.03	3.33	1,601	83.25
	Reciprocating Compressor - 10	1,380	104	1.38	0.20		30.78	1.60	0.29	0.01	64.03	3.33	1,601	83.25
	Reciprocating Compressor - 11	1,380	104	1.38	0.20		30.78	1.60	0.29	0.01	64.03	3.33	1,601	83.25
	Reciprocating Compressor - 12	1,380	104	1.38	0.20		30.78	1.60	0.29	0.01	64.03	3.33	1,601	83.25
	Emergency Shutdown Testing (ESD)	16,560	1	58.93	0.98		---	7.90	---	---	0.07	---	16.44	---
TOTAL:		1,249	TOTAL:	3.35	TOTAL:	30.78	27.11	TOTAL:	0.29	0.25	64.03	56.40	1,601	1,410

Assumes 1 hr/CBD

Source ID	Unit Description (Compressor Blowdown - Raw Natural Gas)	Benzene 25.00 lb/MMscf		Ethylbenzene 25.00 lb/MMscf		n-Hexane 400.00 lb/MMscf		Toluene 25.00 lb/MMscf		2,2,4-TMP 25.00 lb/MMscf		Xylene 25.00 lb/MMscf		Total HAP 525.00 lb/MMscf	
		lb/hr	tpy	lb/hr	tpy	lb/hr	tpy	lb/hr	tpy	lb/hr	tpy	lb/hr	tpy	lb/hr	tpy
CBD/ESD	Reciprocating Compressor - 01	0.05	2E-03	0.05	2E-03	0.76	0.04	0.05	2E-03	0.05	2E-03	0.05	2E-03	1.00	0.05
	Reciprocating Compressor - 02	0.05	2E-03	0.05	2E-03	0.76	0.04	0.05	2E-03	0.05	2E-03	0.05	2E-03	1.00	0.05
	Reciprocating Compressor - 03	0.05	2E-03	0.05	2E-03	0.76	0.04	0.05	2E-03	0.05	2E-03	0.05	2E-03	1.00	0.05
	Reciprocating Compressor - 04	0.05	2E-03	0.05	2E-03	0.76	0.04	0.05	2E-03	0.05	2E-03	0.05	2E-03	1.00	0.05
	Reciprocating Compressor - 05	0.05	2E-03	0.05	2E-03	0.76	0.04	0.05	2E-03	0.05	2E-03	0.05	2E-03	1.00	0.05
	Reciprocating Compressor - 06	0.05	2E-03	0.05	2E-03	0.76	0.04	0.05	2E-03	0.05	2E-03	0.05	2E-03	1.00	0.05
	Reciprocating Compressor - 07	0.05	2E-03	0.05	2E-03	0.76	0.04	0.05	2E-03	0.05	2E-03	0.05	2E-03	1.00	0.05
	Reciprocating Compressor - 08	0.05	2E-03	0.05	2E-03	0.76	0.04	0.05	2E-03	0.05	2E-03	0.05	2E-03	1.00	0.05
	Reciprocating Compressor - 09	0.05	2E-03	0.05	2E-03	0.76	0.04	0.05	2E-03	0.05	2E-03	0.05	2E-03	1.00	0.05
	Reciprocating Compressor - 10	0.05	2E-03	0.05	2E-03	0.76	0.04	0.05	2E-03	0.05	2E-03	0.05	2E-03	1.00	0.05
	Reciprocating Compressor - 11	0.05	2E-03	0.05	2E-03	0.76	0.04	0.05	2E-03	0.05	2E-03	0.05	2E-03	1.00	0.05
	Reciprocating Compressor - 12	0.05	2E-03	0.05	2E-03	0.76	0.04	0.05	2E-03	0.05	2E-03	0.05	2E-03	1.00	0.05
	Emergency Shutdown Testing (ESD)	---	0.01	---	0.01	---	0.20	---	0.01	---	0.01	---	0.01	---	0.26
TOTAL:		0.05	0.04	0.05	0.04	0.76	0.67	0.05	0.04	0.05	0.04	0.05	0.04	1.00	0.88

Assumes 1 hr/CBD

Notes: 1 - The results of a representative **Wet Gas Analysis** were used to determine the following worst-case components (See Appendix A - Lab Data):

Pollutant	Wet Gas	Minimum Contingency: 10%		
		Worst Case	%Total	%VOC
CO2	106 lb/MMscf	150 lb/MMscf	0.23	0.01
Methane (CH4)	30,595 lb/MMscf	33,700 lb/MMscf	52.13	2.08
N2/Water/Ethane/Etc	13,359 lb/MMscf	14,600 lb/MMscf	22.58	0.90
VOC	14,688 lb/MMscf	16,200 lb/MMscf	25.06	1.00
TOTAL Gas	58,748 lb/MMscf	64,650 lb/MMscf	100.00	---

Pollutant	Wet Gas	Worst Case	%Total	%VOC
Benzene	4.12 lb/MMscf	25.00 lb/MMscf	0.04	0.15
Ethylbenzene	0.56 lb/MMscf	25.00 lb/MMscf	0.04	0.15
n-Hexane	344.26 lb/MMscf	400.00 lb/MMscf	0.62	2.47
Toluene	6.80 lb/MMscf	25.00 lb/MMscf	0.04	0.15
2,2,4-TMP	5.12 lb/MMscf	25.00 lb/MMscf	0.04	0.15
Xylenes	3.92 lb/MMscf	25.00 lb/MMscf	0.04	0.15
Total HAP	364.77 lb/MMscf	525.00 lb/MMscf	0.81	3.24

2 - Conversion from Actual Cubic Feet (acf) to Standard Cubic Feet (scf):
 $scf = acf \times [(psig+ave.psia)/(std.psia)] \times [(std.oF+460)/(oF+460)]$
 (https://www.mide.com/pages/air-pressure-at-altitude-calculator)

Description	acf	psig	oF	% Gas	scf
Emergency Shutdown Testing (ESD)	15,000	1,000	100	100	975,903

Hourly ESD Emission are Not Applicable

Ave Atmospheric pressure at: 1,210 ft elev = 14.0645 ave.psia
 Standard Temperature and Pressure: 68.0 std.oF 14.6959 std.psia

Appalachia Midstream Services, LLC (AMS)
Battle Run Compressor Station (BRCS)
 Application for 45CSR13 New Source Review Permit Modification (NSR)

Pigging Operation (PIG) Emissions

Source ID	Description	PIG Volume scf/Event	Pigging Events/yr	Total Gas/Vapor Mscf/yr	Control %	VOC	
						16,200 lb/MMscf-Wet 16,200 lb/MMscf-Dry lb/hr tpy	
PIG	24" Receiver - MCE to OG - Wet Gas	1,649	52	86	---	26.71	0.69
	24" Launcher - WGGG to FBLR - Dry Gas	8,133	52	423		131.75	3.43
TOTAL:			104	509		131.75	4.12

CO2		CH4		CO2e	
150 lb/MMscf-Wet 150 lb/MMscf-Dry lb/hr tpy		33,700 lb/MMscf-Wet 33,700 lb/MMscf-Dry lb/hr tpy		CH4 GWP = 25	
0.25	0.01	55.57	1.44	1,389	36
1.22	0.03	274.07	7.13	6,853	178
1.22	0.04	274.07	8.57	6,853	214

PRE-Control: 131.75 4.12 1.22 0.04 274.07 8.57 6,853 214

Source ID	Description	Benzene		E-Benzene		n-Hexane		Toluene		2,2,4-TMP		Xylene		Tot HAP	
		25 lb/MMscf-Wet 25 lb/MMscf-Dry lb/hr tpy		25 lb/MMscf-Wet 25 lb/MMscf-Dry lb/hr tpy		400 lb/MMscf-Wet 400 lb/MMscf-Dry lb/hr tpy		25 lb/MMscf-Wet 25 lb/MMscf-Dry lb/hr tpy		25 lb/MMscf-Wet 25 lb/MMscf-Dry lb/hr tpy		25 lb/MMscf-Wet 25 lb/MMscf-Dry lb/hr tpy		525 lb/MMscf-Wet 525 lb/MMscf-Dry lb/hr tpy	
PIG	24" Receiver - MCE to OG - Wet Gas	0.04	1E-03	0.04	1E-03	0.66	0.02	0.04	1E-03	0.04	1E-03	0.04	1E-03	0.87	0.02
	24" Launcher - WGGG to FBLR - Dry Gas	0.20	0.01	0.20	0.01	3.25	0.08	0.20	0.01	0.20	0.01	0.20	0.01	4.27	0.11
TOTAL:		0.20	0.01	0.20	0.01	3.25	0.10	0.20	0.01	0.20	0.01	0.20	0.01	4.27	0.13

PRE-Control: 0.20 0.01 0.20 0.01 3.25 0.10 0.20 0.01 0.20 0.01 0.20 0.01 0.20 0.01 4.27 0.13

Notes: 1 - The results of a representative **Wet Gas Analysis** were used to determine the following worst-case components (See Attachment D-3):

Pollutant	Wet Gas	Minimum Contingency: 10%		
		Worst Case	%Total	%VOC
CO2	106 lb/MMscf	150 lb/MMscf	0.23%	0.9%
Methane (CH4)	30,595 lb/MMscf	33,700 lb/MMscf	52.13%	208.0%
N2/Water/Ethane/Etc	13,359 lb/MMscf	14,600 lb/MMscf	22.58%	90.1%
VOC	14,688 lb/MMscf	16,200 lb/MMscf	25.06%	100.00%
TOTAL Wet Gas	58,748 lb/MMscf	64,650 lb/MMscf	100.00%	---
Benzene	4 lb/MMscf	25 lb/MMscf	0.04%	0.15%
Ethylbenzene	1 lb/MMscf	25 lb/MMscf	0.04%	0.15%
n-Hexane	344 lb/MMscf	400 lb/MMscf	0.62%	2.47%
Toluene	7 lb/MMscf	25 lb/MMscf	0.04%	0.15%
2,2,4-TMP	5 lb/MMscf	25 lb/MMscf	0.04%	0.15%
Xylenes	4 lb/MMscf	25 lb/MMscf	0.04%	0.15%
Total HAP	365 lb/MMscf	525 lb/MMscf	0.81%	3.24%

3 - Conversion from Actual Cubic Feet (acf) to Standard Cubic Feet (scf):

$$scf = acf \times [(psig + ave.psia) / (std.psia)] \times [(std.oF + 460) / (oF + 460)]$$

Description	acf	psig	oF	% Gas	scf
24" Receiver - MCE to OG - Wet Gas	100	220	50	100	1,649
24" Launcher - WGGG to FBLR - Dry Gas	125	1,000	100	100	8,133
Emergency Shutdown Testing (ESD)	15,000	1,000	100	100	975,903

Ave Atmospheric pressure at: 1,210 ft elev 14.0645 ave.psia
 Standard Temperature and Pressure: 68.0 std.oF 14.6959 std.psia
 (<https://www.mide.com/pages/air-pressure-at-altitude-calculator>)

4 - Assume each PIG Event takes:

1.00 hr/Event

2 - The results of a representative **Dry Gas Analysis** were used to determine the following worst-case components (See Attachment D-3):

Pollutant	Wet Gas	Minimum Contingency: 10%		
		Worst Case	%Total	%VOC
CO2	106 lb/MMscf	150 lb/MMscf	0.232	---
Methane (CH4)	30,595 lb/MMscf	33,700 lb/MMscf	52.127	---
N2/Water/Ethane/Etc	13,359 lb/MMscf	14,600 lb/MMscf	22.583	---
VOC	14,688 lb/MMscf	16,200 lb/MMscf	25.058	100.000
TOTAL Gas	58,748 lb/MMscf	64,650 lb/MMscf	100.000	---
Benzene	4 lb/MMscf	25 lb/MMscf	0.039	0.154
Ethylbenzene	1 lb/MMscf	25 lb/MMscf	0.039	0.154
n-Hexane	344 lb/MMscf	400 lb/MMscf	0.619	2.469
Toluene	7 lb/MMscf	25 lb/MMscf	0.039	0.154
2,2,4-TMP	5 lb/MMscf	25 lb/MMscf	0.039	0.154
Xylenes	4 lb/MMscf	25 lb/MMscf	0.039	0.154
Total HAP	365 lb/MMscf	525 lb/MMscf	0.812	3.241

Appalachia Midstream Services, LLC (AMS)
Battle Run Compressor Station (BRCS)
 Application for 45CSR13 New Source Review Permit Modification (NSR)

Process Piping and Equipment Leak (FUG-G) Emissions – Gas

Source ID	Description	Component (Unit) Type (Gas)	Unit Count	Const'ive Multiplier 150%	Leak Factor lb/hr/Unit	LDAR Control Credit	Controlled Leaks		VOC 25.058 Wgt%		CO2 0.232 Wgt%		CH4 52.127 Wgt%		CO2e CH4 GWP = 25		
							lb/hr	tpy	lb/hr	tpy	lb/hr	tpy	lb/hr	tpy	lb/hr	tpy	
FUG-G	Process Piping and Equipment Leaks (Gas)	Valves	960	1,440	9.92E-03	---	14.29	62.57	3.58	15.68	0.03	0.15	7.45	32.62	186	816	
		Pump Seals	---	---	5.29E-03	---	---	---	---	---	---	---	---	---	---	---	---
		Other	72	108	1.94E-02	---	2.10	9.18	0.53	2.30	5E-03	0.02	1.09	4.78	27.31	120	
		Connectors	3,132	4,699	4.41E-04	---	2.07	9.07	0.52	2.27	5E-03	0.02	1.08	4.73	27.00	118	
		Flanges	783	1,175	8.60E-04	---	1.01	4.42	0.25	1.11	2E-03	0.01	0.53	2.31	13.16	57.66	
		Open-ended Lines	34	50	4.41E-03	---	0.22	0.97	0.06	0.24	5E-04	2E-03	0.12	0.51	2.90	12.69	
TOTAL:			4,981	7,472			TOTAL:		4.93	21.61	0.05	0.20	10.26	44.94	257	1,124	
PRE-Controlled:									4.93	21.61	0.05	0.20	10.26	44.94	257	1124	

Source ID	Description	Component (Unit) Type (Gas)	Benzene 0.039 Wgt%		Ethylbenzene 0.039 Wgt%		n-Hexane 0.619 Wgt%		Toluene 0.039 Wgt%		2,2,4-TMP 0.039 Wgt%		Xylenes 0.039 Wgt%		Total HAP 0.812 Wgt%	
			lb/hr	tpy	lb/hr	tpy	lb/hr	tpy	lb/hr	tpy	lb/hr	tpy	lb/hr	tpy	lb/hr	tpy
FUG-G	Process Piping and Equipment Leaks (Gas)	Valves	0.01	0.02	0.01	0.02	0.09	0.39	0.01	0.02	0.01	0.02	0.01	0.02	0.12	0.51
		Pump Seals	---	---	---	---	---	---	---	---	---	---	---	---	---	---
		Other	8E-04	4E-03	8E-04	4E-03	0.01	0.06	8E-04	4E-03	8E-04	4E-03	8E-04	4E-03	0.02	0.07
		Connectors	8E-04	4E-03	8E-04	4E-03	0.01	0.06	8E-04	4E-03	8E-04	4E-03	8E-04	4E-03	0.02	0.07
		Flanges	4E-04	2E-03	4E-04	2E-03	0.01	0.03	4E-04	2E-03	4E-04	2E-03	4E-04	2E-03	0.01	0.04
		Open-ended Lines	9E-05	4E-04	9E-05	4E-04	1E-03	0.01	9E-05	4E-04	9E-05	4E-04	9E-05	4E-04	2E-03	0.01
TOTAL:			0.01	0.03	0.01	0.03	0.12	0.53	0.01	0.03	0.01	0.03	0.01	0.03	0.16	0.70
PRE-Controlled:			0.01	0.03	0.01	0.03	0.12	0.53	0.01	0.03	0.01	0.03	0.01	0.03	0.16	0.70

Notes: 1 - Assumed 8,760 hours per year of fugitive emissions.

2 - Gas/Vapor emissions calculated using EPA Protocol for Equipment Leak Emission Estimates, EPA-453/R-95-017, Nov 1995; Table 2-4, Oil and Gas Production Operations:

Equipment Type	Gas		Light Oil		Water/Oil	
	kg/hr	lb/hr/unit	kg/hr	lb/hr/unit	kg/hr	lb/hr/unit
Valves	4.5E-03	9.92E-03	2.5E-03	5.51E-03	9.8E-05	2.16E-04
Pump Seals	2.4E-03	5.29E-03	1.3E-02	2.87E-02	2.4E-05	5.29E-05
Others	8.8E-03	1.94E-02	7.5E-03	1.65E-02	1.4E-02	3.09E-02
Connectors	2.0E-04	4.41E-04	2.1E-04	4.63E-04	1.1E-04	2.43E-04
Flanges	3.9E-04	8.60E-04	1.1E-04	2.43E-04	2.9E-06	6.39E-06
Open-Ended Lines	2.0E-03	4.41E-03	1.4E-03	3.09E-03	2.5E-04	5.51E-04

3 - "Other" components include pressure relief devices (PRD), compressors, diaphragms, drains, meters, etc.

4 - Component counts based on engineering judgment plus a 50% contingency.

5 - The results of a representative **Wet Gas Analysis** were used to determine the following worst-case components (See Appendix A - Lab Data):

Pollutant	Wet Gas	Minimum Contingency: 10%	
		Worst Case	%Total %VOC
CO2	106 lb/MMscf	150 lb/MMscf	0.232 ---
Methane (CH4)	30,595 lb/MMscf	33,700 lb/MMscf	52.127 ---
N2/Water/Ethane/Etc	13,359 lb/MMscf	14,600 lb/MMscf	22.583 ---
VOC	14,688 lb/MMscf	16,200 lb/MMscf	25.058 100.000
TOTAL Gas	58,748 lb/MMscf	64,650 lb/MMscf	100.000 ---
Benzene	4 lb/MMscf	25 lb/MMscf	0.039 0.154
Ethylbenzene	1 lb/MMscf	25 lb/MMscf	0.039 0.154
n-Hexane	344 lb/MMscf	400 lb/MMscf	0.619 2.469
Toluene	7 lb/MMscf	25 lb/MMscf	0.039 0.154
2,2,4-TMP	5 lb/MMscf	25 lb/MMscf	0.039 0.154
Xylenes	4 lb/MMscf	25 lb/MMscf	0.039 0.154
Total HAP	365 lb/MMscf	525 lb/MMscf	0.812 3.241

Process Piping and Equipment Leak (FUG-O) Emissions – Light Oil

Source ID	Description	Component (Unit) Type (Light Liquid)	Unit Count	Const'ive Multiplier 150%	Leak Factor lb/hr/Unit	LDAR Control Credit	Controlled Leaks		VOC		CO2		CH4		CO2e	
							lb/hr	tpy	100.000 Wgt% lb/hr	tpy	--- lb/hr	Wgt% tpy	--- lb/hr	Wgt% tpy	CH4 GWP = 25 lb/hr	tpy
FUG-O	Process Piping and Equipment Leaks (Light Oil)	Valves	576	864	5.51E-03	0%	4.76	20.86	4.76	20.86	---	---	---	---	---	---
		Pump Seals	12	18	2.87E-02	0%	0.52	2.26	0.52	2.26	---	---	---	---	---	---
		Other	43	65	1.65E-02	0%	1.07	4.69	1.07	4.69	---	---	---	---	---	---
		Connectors	1,296	1,944	4.63E-04	0%	0.90	3.94	0.90	3.94	---	---	---	---	---	---
		Flanges	324	486	2.43E-04	0%	0.12	0.52	0.12	0.52	---	---	---	---	---	---
		Open-ended Lines	20	30	3.09E-03	0%	0.09	0.41	0.09	0.41	---	---	---	---	---	---
TOTAL:			2,271	3,407			TOTAL:		7.46	32.68	---	---	---	---	---	
PRE-Controlled:									7.46	32.68	---	---	---	---	---	

Source ID	Description	Component (Unit) Type (Gas)	Benzene 0.154 %VOC		Ethylbenzene 0.154 %VOC		n-Hexane 2.469 %VOC		Toluene 0.154 %VOC		2,2,4-TMP 0.154 %VOC		Xylenes 0.154 %VOC		Total HAP 3.241 %VOC	
			lb/hr	tpy	lb/hr	tpy	lb/hr	tpy	lb/hr	tpy	lb/hr	tpy	lb/hr	tpy	lb/hr	tpy
FUG-O	Process Piping and Equipment Leaks (Light Oil)	Valves	0.01	0.03	0.01	0.03	0.12	0.51	0.01	0.03	0.01	0.03	0.01	0.03	0.15	0.68
		Pump Seals	8E-04	3E-03	8E-04	3E-03	0.01	0.06	8E-04	3E-03	8E-04	3E-03	8E-04	3E-03	0.02	0.07
		Other	2E-03	0.01	2E-03	0.01	0.03	0.12	2E-03	0.01	2E-03	0.01	2E-03	0.01	0.03	0.15
		Connectors	1E-03	0.01	1E-03	0.01	0.02	0.10	1E-03	0.01	1E-03	0.01	1E-03	0.01	0.03	0.13
		Flanges	2E-04	8E-04	2E-04	8E-04	3E-03	0.01	2E-04	8E-04	2E-04	8E-04	2E-04	8E-04	4E-03	0.02
		Open-ended Lines	1E-04	6E-04	1E-04	6E-04	2E-03	0.01	1E-04	6E-04	1E-04	6E-04	1E-04	6E-04	3E-03	0.01
TOTAL:			0.01	0.05	0.01	0.05	0.18	0.81	0.01	0.05	0.01	0.05	0.01	0.05	0.24	1.06
PRE-Controlled:			0.01	0.05	0.01	0.05	0.18	0.81	0.01	0.05	0.01	0.05	0.01	0.05	0.24	1.06

Notes: 1 - Assumed 8,760 hours per year of fugitive emissions.

2 - Light oil emissions calculated using EPA Protocol for Equipment Leak Emission Estimates, EPA-453/R-95-017, Nov 1995; Table 2-4, Oil and Gas Production Operations:

Equipment Type	Gas		Light Oil		Water/Oil	
	kg/hr	lb/hr/unit	kg/hr	lb/hr/unit	kg/hr	lb/hr/unit
Valves	4.5E-03	9.92E-03	2.5E-03	5.51E-03	9.8E-05	2.16E-04
Pump Seals	2.4E-03	5.29E-03	1.3E-02	2.87E-02	2.4E-05	5.29E-05
Others	8.8E-03	1.94E-02	7.5E-03	1.65E-02	1.4E-02	3.09E-02
Connectors	2.0E-04	4.41E-04	2.1E-04	4.63E-04	1.1E-04	2.43E-04
Flanges	3.9E-04	8.60E-04	1.1E-04	2.43E-04	2.9E-06	6.39E-06
Open-Ended Lines	2.0E-03	4.41E-03	1.4E-03	3.09E-03	2.5E-04	5.51E-04

3 - "Other" components include pressure relief devices (PRD), diaphragms, drains, meters, etc.

4 - Component counts based on engineering judgment plus a 50% contingency.

5 - The results of a representative **Wet Gas Analysis** were used to determine the following worst-case components (See Appendix A - Lab Data):

Pollutant	Wet Gas	Minimum Contingency: 10%		
		Worst Case	%Total	%VOC
CO2	106 lb/MMscf	150 lb/MMscf	0.232	---
Methane (CH4)	30,595 lb/MMscf	33,700 lb/MMscf	52.127	---
N2/Water/Ethane/Etc	13,359 lb/MMscf	14,600 lb/MMscf	22.583	---
VOC	14,688 lb/MMscf	16,200 lb/MMscf	25.058	100.000
TOTAL Gas	58,748 lb/MMscf	64,650 lb/MMscf	100.000	---
Benzene	4 lb/MMscf	25 lb/MMscf	0.039	0.154
Ethylbenzene	1 lb/MMscf	25 lb/MMscf	0.039	0.154
n-Hexane	344 lb/MMscf	400 lb/MMscf	0.619	2.469
Toluene	7 lb/MMscf	25 lb/MMscf	0.039	0.154
2,2,4-TMP	5 lb/MMscf	25 lb/MMscf	0.039	0.154
Xylenes	4 lb/MMscf	25 lb/MMscf	0.039	0.154
Total HAP	365 lb/MMscf	525 lb/MMscf	0.812	3.241

Attachment O

Monitoring/Recordkeeping/Reporting/Testing Plans

“31. **Monitoring, Recordkeeping, Reporting and Testing Plans.** Attach proposed monitoring, recordkeeping, reporting and testing plans to demonstrate compliance with the proposed emissions limits and operating parameters in this permit application. Provide this information as Attachment O.”

NOTE: AMS is not submitting any special recommendations for monitoring, recordkeeping, reporting, or testing plans other than those typically established for the emissions units in this application.

Attachment P

Public Notice

“32. **Public Notice.** At the time that the application is submitted, place a **Class I Legal Advertisement** in a newspaper of general circulation in the area where the source is or will be located (See 45CSR§13-8.3 through 45CSR§13-8.5 and Example Legal Advertisement for details). Please submit the **Affidavit of Publication** as Attachment P immediately upon receipt.”

The applicant shall cause such legal advertisement to appear a minimum of one (1) day in the newspaper most commonly read in the area where the facility exists or will be constructed. The notice must be published no earlier than five (5) working days of receipt by this office of your application. The original affidavit of publication must be received by this office no later than the last day of the public comment period.

The advertisement shall contain, at a minimum, the name of the applicant, the type and location of the source, the type and amount of air pollutants that will be discharged, the nature of the permit being sought, the proposed start-up date for the source and a contact telephone number for more information.

The location of the source should be as specific as possible starting with:

- 1) the street address of the source;
- 2) the nearest street or road;
- 3) the nearest town or unincorporated area;
- 4) the county; and
- 5) latitude and longitude coordinates.

Types and amounts of pollutants discharged must include all regulated pollutants (PM, PM10, VOC, SO₂, Xylene, etc.) and their potential to emit or the permit level being sought in units of tons per year (including fugitive emissions).

- Legal Advertisement (as shown) will be placed in a newspaper of general circulation in the area where the source is located (See 45CSR§13-8.3 thru 45CSR§13-8.5).
 - An Affidavit of Publication shall be submitted immediately upon receipt.
-

ATTACHMENT P
Public Notice

AIR QUALITY PUBLIC NOTICE
Notice of Application

Notice is given that Appalachia Midstream Services, LLC has applied to the West Virginia Department of Environmental Protection, Division of Air Quality, for a 45CSR13 NSR Permit Modification for the existing Battle Run Compressor Station (BRCS) located at 297 Windmill Truckers Rd, Valley Grove, in Ohio County, WV 26060.

The latitude and longitude coordinates are 40.073743° North -80.571539° West.

The applicant estimates the increase/(decrease) in the potential to discharge the following regulated air pollutants will be:

- 0.62 tons of nitrogen oxides per year
- 66.05 tons of carbon monoxide per year
- 127.36 tons of volatile organic compounds per year
- (0.62) tons of particulate matter per year
- (0.03) tons of sulfur dioxide per year
- 2.92 tons of total hazardous air pollutants per year
- 20,740 tons of carbon dioxide equivalent per year

Written comments will be received by the West Virginia Department of Environmental Protection, Division of Air Quality, 601 57th Street, SE, Charleston, WV 25304, for at least 30 calendar days from the date of publication of this notice.

Any questions regarding this permit application should be directed to the DAQ at (304) 926-0499, extension 1250, during normal business hours.

Dated this the _____ day of _____ 2018.

By: Appalachia Midstream Services, LLC
Mr. Paul V. Hunter
Vice President
Park Place Corporate Center 2
2000 Commerce Drive
Pittsburgh, PA 15275

Attachment Q
Business Confidential Claims
(Not Applicable)

also

Attachment R
Authority Forms
(Not Applicable)

also

Attachment S
Title V Permit Revision Information
(Not Applicable)

Supplement S1

Lab Analysis (Inlet Gas)

- **Wet Gas – Summary – Battle Run Compressor Station (BRCS)**
 - **Wet Gas – Lab Analysis – Battle Run Compressor Station (BRCS)**
-

Appalachia Midstream Services, LLC (AMS)
Battle Run Compressor Station (BRCS)
 Application for 45CSR13 New Source Review Permit Modification (NSR)

Wet Gas - Summary

Sampled: **11/03/16**

GPSA-Sec 23

Component	CAS	Formula	Molecular Weight (MW)	Mole % (M% = V%)	Mole Fraction (MF)	Ib/MMscf (WS/UGC#)	Weight % Total	Weight % THC	Weight % VOC	Component Btu/scf (HHV)	Btu/scf (HHV)
Water	109-86-4	H2O	18.015	---	---	---	---	---	---	---	---
Carbon Dioxide	124-38-9	CO2	44.010	0.0911	0.040	105.65	0.1798	---	---	---	---
Hydrogen Sulfide	2148-87-8	H2S	34.086	---	---	---	---	---	---	638	---
Nitrogen	7727-37-9	N2	28.013	0.4871	0.136	359.58	0.6121	---	---	---	---
Methane*	75-82-8	CH4	16.042	72.3724	11.610	30,595.16	52.0788	52.4945	---	1,010	730.961
Ethane*	74-84-0	C2H6	30.069	16.4056	4.933	12,999.32	22.1273	22.3039	---	1,770	290.330
Propane**	74-98-6	C3H8	44.096	6.5403	2.884	7,599.80	12.9363	13.0396	51.7410	2,516	164.567
iso-Butane**	75-28-5	C4H10	58.122	0.6839	0.397	1,047.47	1.7830	1.7972	7.1314	3,252	22.240
n-Butane**	106-97-8	C4H10	58.122	1.9846	1.153	3,039.65	5.1741	5.2154	20.6946	3,262	64.746
iso-Pentane**	78-78-4	C5H12	72.149	0.3758	0.271	714.49	1.2162	1.2259	4.8644	4,001	15.035
n-Pentane**	---	C5H12	72.149	0.5583	0.403	1,061.46	1.8068	1.8212	7.2267	4,009	22.382
Cyclopentane**	287-92-3	C5H10	70.100	---	---	---	---	---	---	3,764	---
Cyclohexane**	---	C6H12	84.162	0.0310	0.026	68.75	0.1170	0.1180	0.4681	4,482	1.389
Other Hexanes**	---	C6H14	86.175	0.1663	0.143	377.65	0.6428	0.6480	2.5711	4,750	7.900
Heptanes**	142-82-5	C7H16	100.205	0.0875	0.088	231.05	0.3933	0.3964	1.5730	5,503	4.815
Methylcyclohexane**	108-87-2	C7H14	98.186	0.0210	0.021	54.33	0.0925	0.0932	0.3699	5,216	1.095
C8+ Heavies**	Various	C8+	138.00 est.	0.0354	0.049	128.73	0.2191	0.2209	0.8764	7,000	2.478
Benzene***	71-43-2	C6H6	78.112	0.0020	0.002	4.12	0.0070	0.0071	0.0280	3,742	0.075
Ethylbenzene***	100-41-4	C8H10	106.165	0.0002	0.000	0.56	0.0010	0.0010	0.0038	5,222	0.010
n-Hexane***	110-54-3	C6H14	86.175	0.1516	0.131	344.26	0.5860	0.5907	2.3438	4,756	7.210
Toluene***	108-88-3	C7H8	92.138	0.0028	0.003	6.80	0.0116	0.0117	0.0463	4,475	0.125
2,2,4-Trimethylpentane***	540-84-1	C8H18	114.229	0.0017	0.002	5.12	0.0087	0.0088	0.0348	6,214	0.106
Xylenes***	1330-20-7	C8H10	106.165	0.0014	0.001	3.92	0.0067	0.0067	0.0267	5,209	0.073

#UGC (Universal Gas Constant)
 = 379.482 scf/lb-mol @ 60 oF and 14.6959 psia.

Ib "X"/scf =
 (M% of "X") x (MW of "X") / #UGC

Totals:	100.0000	22.29	58,747.87
THC:	99.4218	22.12	58,282.64
Total VOC:	10.6438	5.57	14,688.16
Total HAP:	0.1597	0.14	364.77

100.0000	---	---
99.2081	100.0000	---
25.0020	25.2016	100.0000
0.6209	0.6259	2.4834

Calculated Btu/scf (HHV):	1,352
Worst-Case Btu/scf (HHV):	1,020

Component	Representative Gas Analysis		
	Mole %	Wgt %	Ib/MMscf
CO2	0.091	0.1798	105.65
Methane*	72.372	52.0788	30,595.16
Other (N2, C2, O2, CO, H2O)	16.893	22.7394	13,358.89
VOC**	10.644	25.0020	14,688.16
TOTAL GAS	100.000	100.0000	58,747.87
Benzene***	0.002	0.0070	4.12
Ethylbenzene***	2E-04	0.0010	0.56
n-Hexane***	0.152	0.5860	344.26
Toluene***	0.003	0.0116	6.80
2,2,4-Trimethylpentane***	0.002	0.0087	5.12
Xylenes***	0.001	0.0067	3.92
Total HAP***	0.160	0.6209	364.77

Assumed "Worst-Case" Min Margin: 10%	
Wgt %	Ib/MMscf
0.2320	150.00
52.1268	33,700.00
22.5831	14,600.00
25.0580	16,200.00
100.0000	64,650.00
0.0387	25.00
0.0387	25.00
0.6187	400.00
0.0387	25.00
0.0387	25.00
0.0387	25.00
0.8121	525.00

* = Hydrocarbon (HC)
 ** = also Volatile Organic Compound (VOC)
 *** = also Hazardous Air Pollutant (HAP)

**Williams Quality Control Facility
Extended Analysis by GPA 2186**

Sample Information

Sample Information	
Sample Name	BATTLE RUN CF DEHY INLET
Meter Number	Operational - Environmental
Effective Date	12/01/2016 10:00:00
Sample Date	11/03/2016 10:35:00
Sample Type	S
Field Remarks	None
Office Remarks	None
Sample Technician	FR
Sample Pressure, psig	1020
Sample Temperature, deg F	95
Sample Bottle No.	7037
Calibration Name	GPA 2286 Ext Gas Analysis - LOW C1
Injection Date	2016-11-04 11:51:01
Report Date	2016-11-04 12:23:22
EZReporter Configuration File	Utica Gas Extended Analysis - May 2016.cfgx

Component Results

Component Name	Ret. Time	Peak Area	Norm Mole%
Nitrogen	3.56	4.800	0.4871
Methane	3.49	393.038	72.3724
Carbon Dioxide	4.52	1.000	0.0911
Ethane	3.63	176.578	16.4056
Propane	3.94	105.227	6.5403
iso-Butane	4.42	14.619	0.6839
n-Butane	4.82	42.673	1.9846
Neopentane	5.03	0.236	0.0086
iso-Pentane	6.20	10.173	0.3758
n-Pentane	6.84	14.941	0.5497
Hexanes Plus	0.00	0.000	0.5009
Total:			100.0000

Battle Run Compressor Station (BRCS)

Application for 45CSR13 New Source Review Permit Modification (NSR)

Wet Gas - Lab Analysis

Component	Weight%	Mole%	Volume%
Nitrogen	0.6125	0.4871	0.2690
Methane	52.1175	72.3724	61.5791
Carbon Dioxide	0.1800	0.0911	0.0780
Ethane	22.1437	16.4056	22.0265
Propane	12.9459	6.5403	9.0472
iso-Butane	1.7843	0.6839	1.1232
n-Butane	5.1778	1.9846	3.1412
Neopentane	0.0279	0.0086	0.0166
iso-Pentane	1.2171	0.3758	0.6906
n-Pentane	1.7803	0.5497	0.9995
2,2-Dimethylbutane	0.0325	0.0084	0.0176
2,3-Dimethylbutane/Cyclopentane	0.0614	0.0175	0.0308
2-Methylpentane	0.3150	0.0898	0.1580
3-Methylpentane	0.1957	0.0506	0.1036
n-Hexane	0.5864	0.1516	0.3129
2,2-Dimethylpentane	0.0076	0.0017	0.0040
Methylcyclopentane/2,4-Dimethylpentane	0.0601	0.0159	0.0282
Benzene	0.0070	0.0020	0.0028
3,3-Dimethylpentane	0.0049	0.0011	0.0025
Cyclohexane	0.0570	0.0151	0.0258
2-Methylhexane	0.0895	0.0199	0.0464
2,3-Dimethylpentane	0.0202	0.0045	0.0102
3-Methylhexane	0.0972	0.0216	0.0498
trans-1,3-Dimethylcyclopentane	0.0076	0.0017	0.0039
cis-1,3-Dimethylcyclopentane	0.0063	0.0014	0.0032
2,2,4-Trimethylpentane	0.0087	0.0017	0.0044
3-Ethylpentane	0.0054	0.0012	0.0027
n-Heptane	0.1687	0.0375	0.0868
cis-1,2-Dimethylcyclopentane	0.0021	0.0004	0.0011
Methylcyclohexane/1,1,3-Trimethylcyclopentane/2,2-Dimethylhexane	0.0771	0.0175	0.0353
2,5-Dimethylhexane	0.0041	0.0008	0.0021
2,4-Dimethylhexane/Ethylcyclopentane/2,2,3-Trimethylpentane	0.0108	0.0021	0.0054
3,3-Dimethylhexane	0.0041	0.0008	0.0021
trans-1,2-cis-3-Trimethylcyclopentane	0.0015	0.0003	0.0008
Toluene	0.0116	0.0028	0.0047
1,1,2-Trimethylcyclopentane	0.0041	0.0008	0.0021
2-Methylheptane/4-Methylheptane	0.0282	0.0055	0.0142
3-Methylheptane	0.0220	0.0043	0.0110
3-Ethylhexane	0.0292	0.0057	0.0146
trans-1,2-Dimethylcyclohexane	0.0031	0.0006	0.0016
cis-1,3-Dimethylcyclohexane	0.0121	0.0024	0.0056
1,1-Dimethylcyclohexane	0.0031	0.0006	0.0016
2,2,4-Trimethylhexane	0.0015	0.0003	0.0008
n-Octane	0.0364	0.0071	0.0183
trans-1,3-Dimethylcyclohexane	0.0030	0.0006	0.0014
1-Methyl-cis-2-Ethylcyclopentane	0.0017	0.0003	0.0008
cis-1,2-Dimethylcyclohexane	0.0025	0.0005	0.0011
2,3,3-Trimethylhexane	0.0012	0.0002	0.0006
1,1,4-Trimethylcyclohexane	0.0006	0.0001	0.0003
2,3,4-Trimethylhexane	0.0006	0.0001	0.0003
Ethylbenzene	0.0010	0.0002	0.0004
2,3-Dimethylheptane	0.0012	0.0002	0.0006
m-Xylene	0.0057	0.0012	0.0023
o-Xylene	0.0010	0.0002	0.0004
1,1,2-Trimethylcyclohexane	0.0006	0.0001	0.0003
n-Nonane	0.0075	0.0013	0.0037
n-Propylcyclohexane	0.0006	0.0001	0.0003
m-Ethyltoluene	0.0006	0.0001	0.0003
p-Ethyltoluene	0.0006	0.0001	0.0003
2-Methylnonane	0.0006	0.0001	0.0003
1,2,4-Trimethylbenzene/tert-Butylbenzene/Methylcyclooctane	0.0005	0.0001	0.0002
n-Decane	0.0013	0.0002	0.0006
Total:	100.0000	100.0000	100.0000

Supplement S2

Vendor Data

- 1380 bhp CAT G3516B w/ Emit OxCat
 - 605 bhp Baldor IGLC420-2N w/ NSCR
 - BTEX Buster (Condenser)
 - Vapor Recovery Unit (VRU)
 - Carbon Canister (CarbCan)
-

GAS COMPRESSION APPLICATION

ENGINE SPEED (rpm): 1400
 COMPRESSION RATIO: 8:1
 AFTERCOOLER - STAGE 2 INLET (°F): 130
 AFTERCOOLER - STAGE 1 INLET (°F): 201
 JACKET WATER OUTLET (°F): 210
 ASPIRATION: TA
 COOLING SYSTEM: JW+OC+1AC, 2AC
 IGNITION SYSTEM: ADEM3
 EXHAUST MANIFOLD: DRY
 COMBUSTION: Ultra Lean Burn
 NOX EMISSION LEVEL (g/bhp-hr NOx): 0.5
 SET POINT TIMING: 28

FUEL SYSTEM:
SITE CONDITIONS:
 FUEL:
 FUEL PRESSURE RANGE(psig):
 FUEL METHANE NUMBER:
 FUEL LHV (Btu/scf):
 ALTITUDE(ft):
 MAXIMUM INLET AIR TEMPERATURE(°F):
 STANDARD RATED POWER:

CAT WIDE RANGE
 WITH AIR FUEL RATIO CONTROL

Gantzer 10H

7.0-50.0

43.9

1216

500

77

1380 bhp@1400rpm

RATING	NOTES	LOAD	MAXIMUM RATING	SITE RATING AT MAXIMUM INLET AIR TEMPERATURE		
			100%	100%	75%	50%
ENGINE POWER (WITHOUT FAN)	(1)	bhp	1371	1371	1028	690
INLET AIR TEMPERATURE		°F	77	77	77	77

ENGINE DATA							
FUEL CONSUMPTION (LHV)		(2)	Btu/bhp-hr	7396	7396	7921	8500
FUEL CONSUMPTION (HHV)		(2)	Btu/bhp-hr	8138	8138	8716	9353
AIR FLOW (77°F, 14.7 psia)	(WET)	(3)(4)	scfm	3118	3118	2446	1720
AIR FLOW	(WET)	(3)(4)	lb/hr	13826	13826	10846	7626
INLET MANIFOLD PRESSURE		(5)	in Hg(abs)	91.6	91.6	74.4	52.6
EXHAUST TEMPERATURE - ENGINE OUTLET		(6)	°F	1024	1024	1017	1037
EXHAUST GAS FLOW (@engine outlet temp, 14.5 psia)	(WET)	(7)(4)	ft3/min	9227	9227	7215	5148
EXHAUST GAS MASS FLOW	(WET)	(7)(4)	lb/hr	14314	14314	11237	7908

EMISSIONS DATA - ENGINE OUT							
NOx (as NO2)		(8)(9)	g/bhp-hr	0.50	0.50	0.50	0.50
CO		(8)(9)	g/bhp-hr	3.10	3.10	3.32	3.26
THC (mol. wt. of 15.84)		(8)(9)	g/bhp-hr	4.06	4.06	4.35	4.41
NMHC (mol. wt. of 15.84)		(8)(9)	g/bhp-hr	2.03	2.03	2.18	2.21
NMNEHC (VOCs) (mol. wt. of 15.84)		(8)(9)(10)	g/bhp-hr	1.04	1.04	1.11	1.13
HCHO (Formaldehyde)		(8)(9)	g/bhp-hr	0.36	0.36	0.35	0.35
CO2		(8)(9)	g/bhp-hr	527	527	563	611
EXHAUST OXYGEN		(8)(11)	% DRY	9.1	9.1	8.8	8.4

HEAT REJECTION							
HEAT REJ. TO JACKET WATER (JW)		(12)	Btu/min	21373	21373	20032	18830
HEAT REJ. TO ATMOSPHERE		(12)	Btu/min	6083	6083	5072	4074
HEAT REJ. TO LUBE OIL (OC)		(12)	Btu/min	4462	4462	3967	3363
HEAT REJ. TO A/C - STAGE 1 (1AC)		(12)(13)	Btu/min	9231	9231	7552	2392
HEAT REJ. TO A/C - STAGE 2 (2AC)		(12)(13)	Btu/min	5248	5248	4962	3291

COOLING SYSTEM SIZING CRITERIA			
TOTAL JACKET WATER CIRCUIT (JW+OC+1AC)	(13)(14)	Btu/min	38558
TOTAL AFTERCOOLER CIRCUIT (2AC)	(13)(14)	Btu/min	5510

A cooling system safety factor of 0% has been added to the cooling system sizing criteria.

CONDITIONS AND DEFINITIONS

Engine rating obtained and presented in accordance with ISO 3046/1, adjusted for fuel, site altitude and site inlet air temperature. 100% rating at maximum inlet air temperature is the maximum engine capability for the specified fuel at site altitude and maximum site inlet air temperature. Max. rating is the maximum capability for the specified fuel at site altitude and reduced inlet air temperature. Lowest load point is the lowest continuous duty operating load allowed. No overload permitted at rating shown.

For notes information consult page three.

Engine Power vs. Inlet Air Temperature

Data represents temperature sweep at 500 ft and 1400 rpm

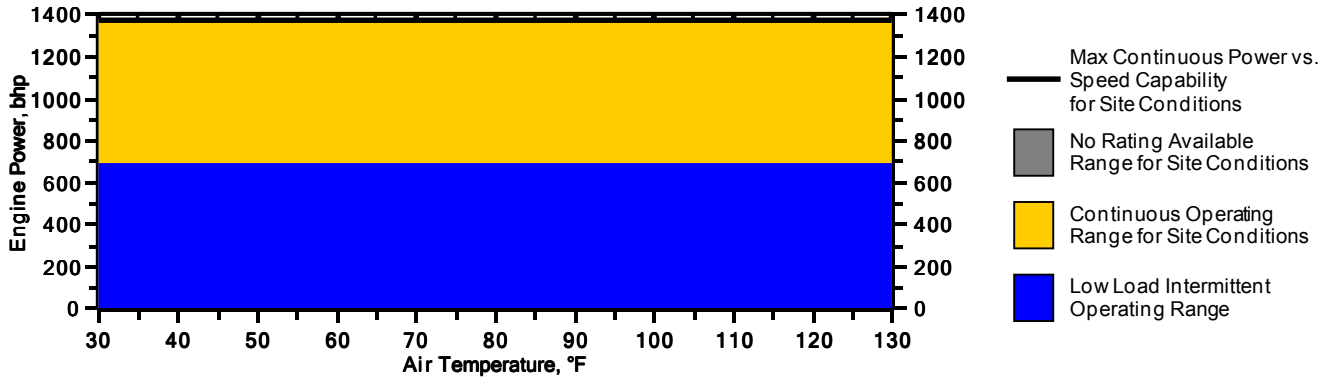

Engine Power vs. Engine Speed

Data represents speed sweep at 500 ft and 77 °F

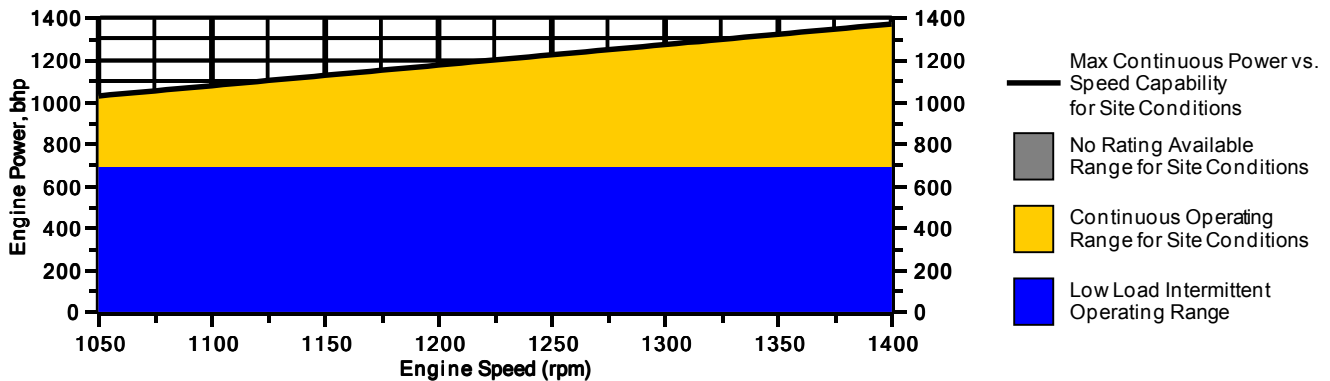

Engine Torque vs. Engine Speed

Data represents speed sweep at 500 ft and 77 °F

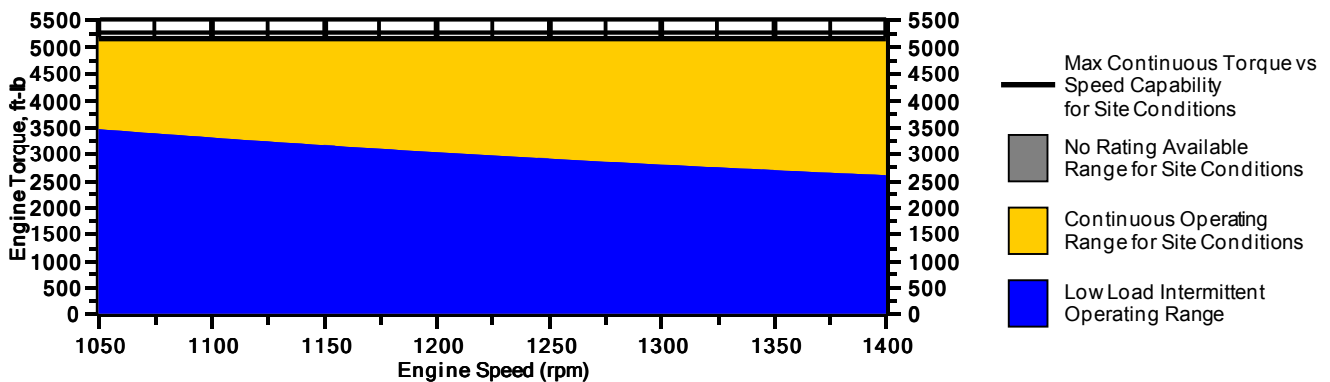

Note: At site conditions of 500 ft and 77°F inlet air temp., constant torque can be maintained down to 1050 rpm. The minimum speed for loading at these conditions is 1050 rpm.

G3516B

GAS COMPRESSION APPLICATION

**GAS ENGINE SITE SPECIFIC TECHNICAL DATA
Gantzer 10H****NOTES**

1. Engine rating is with two engine driven water pumps. Tolerance is $\pm 3\%$ of full load.
2. Fuel consumption tolerance is $\pm 3.0\%$ of full load data.
3. Air flow value is on a 'wet' basis. Flow is a nominal value with a tolerance of $\pm 5\%$.
4. Inlet and Exhaust Restrictions must not exceed A&I limits based on full load flow rates from the standard technical data sheet.
5. Inlet manifold pressure is a nominal value with a tolerance of $\pm 5\%$.
6. Exhaust temperature is a nominal value with a tolerance of (+)63°F, (-)54°F.
7. Exhaust flow value is on a "wet" basis. Flow is a nominal value with a tolerance of $\pm 6\%$.
8. Emissions data is at engine exhaust flange prior to any after treatment.
9. Emission values are based on engine operating at steady state conditions. Fuel methane number cannot vary more than ± 3 . Values listed are higher than nominal levels to allow for instrumentation, measurement, and engine-to-engine variations. They indicate "Not to Exceed" values. THC, NMHC, and NMNEHC do not include aldehydes. An oxidation catalyst may be required to meet Federal, State or local CO or HC requirements.
10. VOCs - Volatile organic compounds as defined in US EPA 40 CFR 60, subpart JJJJ
11. Exhaust Oxygen level is the result of adjusting the engine to operate at the specified NOx level. Tolerance is ± 0.5 .
12. Heat rejection values are nominal. Tolerances, based on treated water, are $\pm 10\%$ for jacket water circuit, $\pm 50\%$ for radiation, $\pm 20\%$ for lube oil circuit, and $\pm 5\%$ for aftercooler circuit.
13. Aftercooler heat rejection includes an aftercooler heat rejection factor for the site elevation and inlet air temperature specified. Aftercooler heat rejection values at part load are for reference only. Do not use part load data for heat exchanger sizing.
14. Cooling system sizing criteria are maximum circuit heat rejection for the site, with applied tolerances.

Constituent	Abbrev	Mole %	Norm
Water Vapor	H2O	0.0000	0.0000
Methane	CH4	71.4070	71.4070
Ethane	C2H6	17.4920	17.4920
Propane	C3H8	6.7840	6.7840
Isobutane	iso-C4H10	0.6640	0.6640
Norbutane	nor-C4H10	1.8620	1.8620
Isopentane	iso-C5H12	0.3070	0.3070
Norpentane	nor-C5H12	0.4650	0.4650
Hexane	C6H14	0.3740	0.3740
Heptane	C7H16	0.0000	0.0000
Nitrogen	N2	0.4920	0.4920
Carbon Dioxide	CO2	0.1530	0.1530
Hydrogen Sulfide	H2S	0.0000	0.0000
Carbon Monoxide	CO	0.0000	0.0000
Hydrogen	H2	0.0000	0.0000
Oxygen	O2	0.0000	0.0000
Helium	HE	0.0000	0.0000
Neopentane	neo-C5H12	0.0000	0.0000
Octane	C8H18	0.0000	0.0000
Nonane	C9H20	0.0000	0.0000
Ethylene	C2H4	0.0000	0.0000
Propylene	C3H6	0.0000	0.0000
TOTAL (Volume %)		100.0000	100.0000

Fuel Makeup: Gantzer 10H
 Unit of Measure: English

Calculated Fuel Properties

Caterpillar Methane Number:	43.9
Lower Heating Value (Btu/scf):	1216
Higher Heating Value (Btu/scf):	1338
WOBBE Index (Btu/scf):	1387
THC: Free Inert Ratio:	154.04
Total % Inerts (% N2, CO2, He):	0.65%
RPC (%) (To 905 Btu/scf Fuel):	100%
Compressibility Factor:	0.996
Stoich A/F Ratio (Vol/Vol):	12.58
Stoich A/F Ratio (Mass/Mass):	16.37
Specific Gravity (Relative to Air):	0.769
Specific Heat Constant (K):	1.271

CONDITIONS AND DEFINITIONS

Caterpillar Methane Number represents the knock resistance of a gaseous fuel. It should be used with the Caterpillar Fuel Usage Guide for the engine and rating to determine the rating for the fuel specified. A Fuel Usage Guide for each rating is included on page 2 of its standard technical data sheet.

RPC always applies to naturally aspirated (NA) engines, and turbocharged (TA or LE) engines only when they are derated for altitude and ambient site conditions.

Project specific technical data sheets generated by the Caterpillar Gas Engine Rating Pro program take the Caterpillar Methane Number and RPC into account when generating a site rating.

Fuel properties for Btu/scf calculations are at 60F and 14.696 psia.

Caterpillar shall have no liability in law or equity, for damages, consequently or otherwise, arising from use of program and related material or any part thereof.

FUEL LIQUIDS

Field gases, well head gases, and associated gases typically contain liquid water and heavy hydrocarbons entrained in the gas. To prevent detonation and severe damage to the engine, hydrocarbon liquids must not be allowed to enter the engine fuel system. To remove liquids, a liquid separator and coalescing filter are recommended, with an automatic drain and collection tank to prevent contamination of the ground in accordance with local codes and standards.

To avoid water condensation in the engine or fuel lines, limit the relative humidity of water in the fuel to 80% at the minimum fuel operating temperature.

Prepared For:

Jason Stinson
 MIDCON COMPRESSION, LP

INFORMATION PROVIDED BY CATERPILLAR

Engine: G3516B
 Horsepower: 1371
 RPM: 1400
 Compression Ratio: 8.0:1
 Exhaust Flow Rate: 9227 CFM
 Exhaust Temperature: 1024 °F
 Reference: DM8800-04
 Fuel: Natural Gas
 Annual Operating Hours: 8760

Uncontrolled Emissions

NOx: 0.50 g/bhp-hr
 CO: 3.10 g/bhp-hr
 THC: 4.06 g/bhp-hr
 NMHC: 2.03 g/bhp-hr
 NMNEHC: 1.04 g/bhp-hr
 HCHO: 0.36 g/bhp-hr
 Oxygen: 9.10 %

POST CATALYST EMISSIONS

NOx: Unaffected by Oxidation Catalyst
 CO: >98% Reduction
 VOC: >80% Reduction
 HCHO: >95% Reduction

CONTROL EQUIPMENT

Catalytic Converter

Model: ELH-4200V-1616F-42CEE-242
 Catalyst Type: VOC, Precious group metals
 Manufacturer: EMIT Technologies, Inc.
 Element Size: Rectangle 24 x 15 x 3.5
 Catalyst Elements: 2
 Housing Type: 4 Element Capacity
 Catalyst Installation: Accessible Housing
 Construction: 10 gauge Carbon Steel
 Sample Ports: 6 (0.5" NPT)
 Inlet Connections: 16" Flat Face Flange
 Outlet Connections: 16" Flat Face Flange
 Configuration: End In / End Out
 Silencer: Integrated
 Silencer Grade: Hospital
 Insertion Loss: 35-40 dBA



WARRANTY

EMIT Technologies, Inc. warrants that the goods supplied will be free from defects in workmanship by EMIT Technologies, Inc. for a period of one (1) year from date of shipment. EMIT Technologies, Inc. will not be responsible for any defects which result from improper use, neglect, failure to properly maintain or which are attributable to defects, errors or omissions in any drawings, specifications, plans or descriptions, whether written or oral, supplied to EMIT Technologies, Inc. by Buyer.

Catalyst performance will be guaranteed for a period of 1 year from installation, or 8760 operating hours, whichever comes first. The catalyst (Rich Burn Engines Only) shall be operated with an automatic air/fuel ratio controller. The performance guarantee shall not cover the effects of excessive ash masking due to operation at low load, improper engine maintenance, or inappropriate lubrication oil. The performance guarantee shall not cover the effects of continuous engine misfires (cylinder or ignition) exposing the catalyst to excessive exothermic reaction temperatures.

The exhaust temperature operating range at the converter inlet is 600°F minimum for oxidation catalyst and 750 °F for NSCR catalyst and 1250°F maximum.

If a high temperature shut down switch is not installed, thermal deactivation of catalyst at temperatures above 1300 °F is not covered.

The catalyst conversion efficiencies (% reduction) will be guaranteed for engine loads of 50 to 100 percent.

Engine lubrication oil shall contain less than 0.6% ash (by weight) with a maximum allowable specific oil consumption of 0.01 gal/bhp-hr. The maximum ash loading on the catalyst shall be limited to 350 g/m³. Phosphorous and zinc additives are limited to 0.03% (by weight).

The catalyst must not be exposed to the following know poisoning agents, including: iron, nickel, sodium, chromium, arsenic, zinc, lead, phosphorous, silicon, potassium, magnesium, copper, tin, and mercury. Total poison concentrations in the gas are limited to 0.3 ppm.

21.9L NG ENGINE

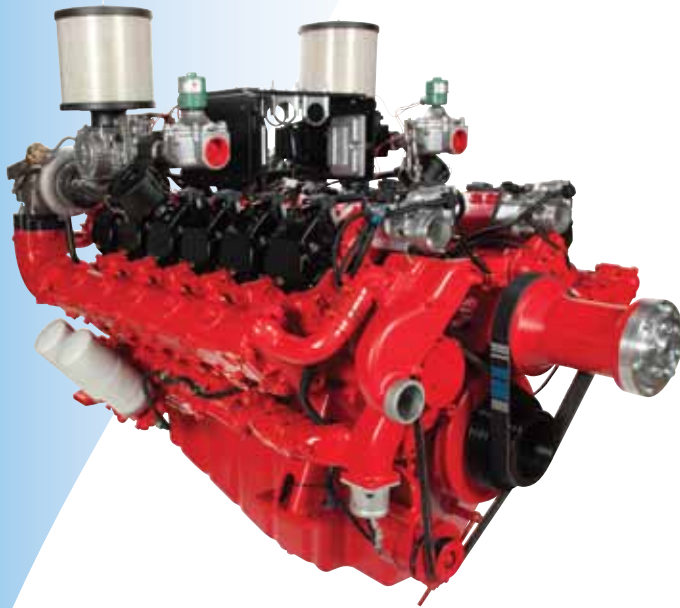

FEATURES / OPTIONS

- US –EPA Certified and CARB Compliant
- Power: 455kWm Standby on NG
- Integrated Engine Controls Protection with CANBUS
- 50c Ambient Cooling Capacity
- UL2200 Compliant or Listed Components
- MasterTrak Telematics service (included for 1 year)

DESCRIPTION

The NGE 21.9L is a US-EPA CERTIFIED Natural Gas and Propane engine. Built upon a proven marine-diesel grade block, the 12-Cylinder V, turbocharged and after-cooled engine features replaceable wet liners and watercooled exhaust. The engine was developed from the block-up to be a reliable and durable power unit.

Superior engine performance is provided by an ECU that integrates and coordinates all critical functions including: Governor, Variable Ignition Timing, Air:Fuel Ratio Control, Knock Suppression and Engine Protection.

NGEngines is an extension of the Power Solutions, Inc. (PSI) product line which is based upon GM blocks from 650cc to 8.1L. The NGE product lineup has 5 models with displacements of 8.1L, 11.1L, 14.6L, 18.3L and 21.9L. All PSI/NGE engines feature the same fuel systems and controls simplifying your application development and support.

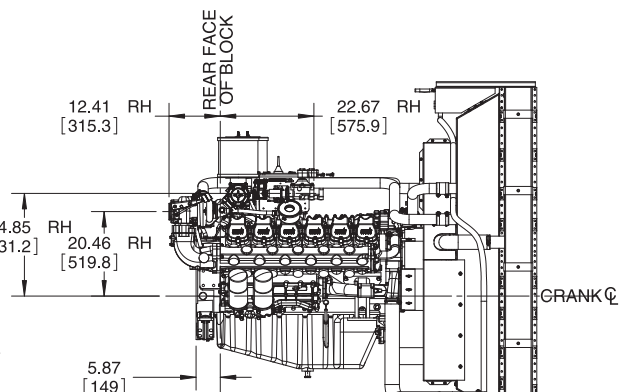
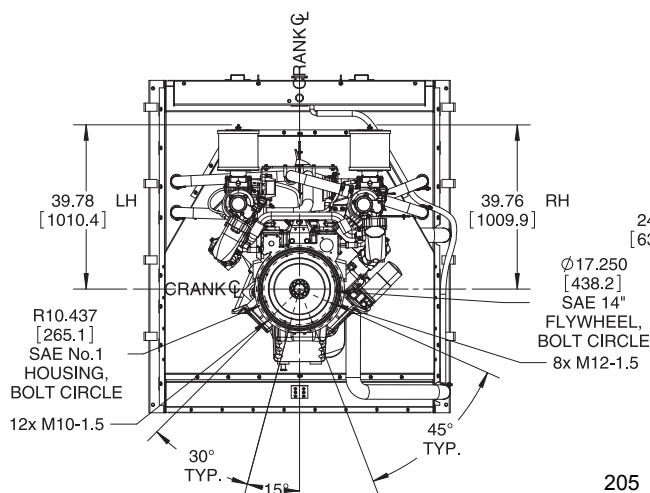



21.9L

	UNITS		21.9L CAC			
	STD	METRIC	1500		1800	
GENERAL ENGINE MOUNTING						
Type	N/A		V-type 4 cycle			
Number of cylinders	N/A		12			
Aspiration	N/A		Turbo Charge Air Cooled			
Bore	in	mm	5.04	128	5.04	128
Stroke	in	mm	5.59	142	5.59	142
Displacement	in^3	L	1338	21.93	1338	21.93
Compression Ratio	N/A		10.5			
Mean Piston Speed	ft/min	m/s	1398	7.10	1677	8.52
Rated Load	Hp	kW	516	385	605	451
MEP (@ rated Load)	psi	kPa	204	14	199	14
Rotation Viewed from Flywheel	N/A		Counter Clockwise			
Firing Order	N/A		1-12-5-8-3-10-6-7-2-11-4-9			
DRY WEIGHT						
Fan to Flywheel	lb	kg	3638	1650	3638	1650
Rad to Flywheel	lb	kg	5238	2376	5238	2376
WET WEIGHT						
Fan to Flywheel	lb	kg	3813	1706	3813	1706
Rad to Flywheel	lb	kg	5884	2688	5884	2688
CG						
Distance from FW housing	in	mm	7.17	182	7.17	182
Distance above center of crankshaft	in	mm	23.71	602.2	23.71	602.2
ENGINE MOUNTING						
Maximum Allowable Bending Moment at Rear of Block	lb ft	N m	0	0	0	0
Moment of Inertia About Roll Axis	lb ft^2	kg m^2	0	0	0	0
Flywheel housing	N/A		SAE No. 1			
Flywheel	N/A		No. 14			
EXHAUST SYSTEM						
Type						
Maximum allowable Back pressure	in HG	kPa	3	10.2	3	10.2
Standard Catalyst Back pressure	in HG	kPa	1.5	5.1	1.5	5.1
Exhaust Outlet Pipe Size						
Maximum Turbine Inlet Temperature	F	C	1382	750	1382	750
Exhaust Flow at Rated Power	lb/hr	kg/hr	3191	1448	3939	1787
Exhaust Flow at Rated Power @1350F	cfm	m^3/min	2427	68.7	2995	84.8
AIR INDUCTION SYSTEM						
Maximum allowable Intake Air Restriction with Air Cleaner						
Clean	inH2O	kPa	5	1.24	5	1.24
Dirty	inH2O	kPa	15	3.74	15	3.74
Combustion Air required	lb/hr	kg/hr	3004	1362	3707	1682
Combustion Air required	cfm	m^3/min	681	19.9	841	24.6
ELECTRICAL SYSTEM						
Minimum Recommended Battery Capacity	AH		200			
Cold Cranking Current						
Engine only	CCA		1000			
Engine with Drive train	CCA		1000			
Maximum Allowable Resistance of Starting Circuit	Ohms		0.002			
Starting Motor Power	HP	kW	9.4	7	9.4	7
Battery Charging Alternator						
Voltage	Volts		24			
Current	Amps		45			

	UNITS		21.9L CAC			
	STD	METRIC	1500		1800	
COOLING SYSTEM						
Coolant Capacity						
Engine only	gal	L	11.5	52.3	11.5	52.3
Engine with Radiator	gal	L	64	291	64	291
Engine Coolant Flow	gal/min	L/min	145	550	174	660
Water Pump Speed	RPM		0	0	0	0
Heat rejected to Cooling water at rated Load	btu/min	kcal/sec	21451	90.1	25760	108.2
Maximum Intake Air Temperature (IAT)	F	C	155	68	155	68
ECU IAT Warning	F	C	0	0	0	0
ECU IAT Shutdown	F	C	0	0	0	0
Maximum Coolant Friction Head External to the engine	psi	bar	5.8	0.4	5.8	0.4
Maximum Air Restriction Across a Radiator	inH2O	mmH2O	0.5	12.8	0.5	12.8
Standard Thermostat Range						
Cracking Temperature	F	C	160	71	160	71
Full Open Temperature	F	C	185	85	185	85
Maximum Output Pressure of Engine Water Pump						
Maximum Allowable Pressure Cap	psi	bar	14.7	1	14.7	1
Ambient Clearance Open Genset (water)						
Specified	F	C	122	50	122	50
Ambient Clearance (Oil)						
Specified	F	C	122	50	122	50
Maximum Allowable Top Tank Temperature	F	C	230	110	230	110
ECU Warning	F	C	220	104	220	104
ECU Shutdown	F	C	230	110	230	110
Fan Power	HP	kW	24	17.9	42	31.3
Fan Diameter, including blades	in	mm	52	1321	52	1321
Fan Speed	RPM		1200		1440	
Cooling Fan Air Flow @ 1" H2O Stat. Press and 125F @ Rad	CFM	m^3/min	34286	970.8	40000	1132.6
Charge Air Cooler						
Compressor Outlet Temperature	F	C	245.6	120	302.6	152.0
Compressor Flow Rate	CFM	m^3/min	0	0	1254	35.5
LUBRICATION SYSTEM						
Oil Specification	SAE 15W-40 Low Ash Gas engine oil (.25-.5% by wt), API CD/CF or higher					
Oil Pressure						
Idle						
Min	Psi	Bar	13	0.9	13	0.9
Max	Psi	Bar	43.5	3	43.5	3
Rated Speed						
Min	Psi	Bar	43.5	3	43.5	3
Max	Psi	Bar	94.5	6.5	94.5	6.5
Maximum Allowable Oil Temperature	F	C	230	110	230	110
Engine Oil Capacity						
Min	Qts	L	34.75	33	34.75	33
Max	Qts	L	42.25	40.0	42.25	40.0
Oil Filter Capacity	Qts	L	7.5	7.1	7.5	7.1
FUEL SYSTEM						
Low Pressure Dry Processed Natural Gas (Spec)						
Fuel Composition						
Maximum EPR Rated Pressure	psi	kPa	1	6.89	1	6.89
Maximum Running pressure to Electronic Pressure Regulator (EPR)	inH2O	kPa	11	2.74	11	2.74
Minimum Running pressure to EPR	inH2O	kPa	7	1.74	7	1.74
Minimum Gas Supply Pipe Size			2 x 2" NPT			
Low Pressure Vapor Propane (HD5)						
Fuel Composition						
Maximum EPR Rated Pressure	psi	kPa	1	6.89	1	6.89
Maximum Running Pressure to EPR	inH2O	kPa	11	2.74	11	2.74
Minimum Running Pressure to EPR	inH2O	kPa	7	1.74	7	1.74
Minimum LPG Supply Pipe Size			2 x 2" NPT			

206 The preceding pipe sizes are only suggestions and piping sizes may vary with temperature, pressure, distance from supply and application of local codes. Gas must be available at adequate volume and pressure for engine at the EPR.



IGLC420-2N

Gaseous Fuel

Ratings Range – 60 Hertz Operation

Liquid Propane: kW 175 - 259
kVA 175 - 324

Natural Gas: kW 175 - 396
kVA 175 - 495

Baldor generators are available in a variety of power ratings and installation styles to meet the energy needs of the smallest businesses and the largest manufacturing facilities. All generator sets are designed to meet the specifications to ensure the fastest startup and dependable long-term operation. Rely on Baldor generators to provide the clean, quiet and environmentally friendly electrical power when you need it most. Emergency backup, standby, peak shaving or for any of your day or night electrical power needs, you can count on a dependable Baldor generator to provide the peace of mind and security you desire.

Standby Power Features

- ✓ Heavy-duty industrial gaseous fuel engine that meets the latest EPA emissions levels
- ✓ Brushless synchronous alternators with dynamic balancing and four pole construction
- ✓ Fully featured microprocessor based controller that's easy to use and field programmable for customized installations
- ✓ Generator sets are prototype tested and production tested to ensure easy startup
- ✓ Gen-set accepts rated load in one step
- ✓ Heavy duty construction that's designed for use in standby applications
- ✓ Manufactured in a dedicated and secure ISO-9001 certified facility
- ✓ Generator sets are backed by a world wide network of parts and service centers
- ✓ Optional agency approvals available including UL2200 and NFPA110
- ✓ Optional environmental enclosures available including weather resistant, sound attenuated, containerized, and walk-in models
- ✓ Full range of genset accessories and factory installed options available

Genset Ratings

Genset Model Number	Alternator	Voltage L-L / L-N	Phase	Hertz	150°C Rise Alternator Standby Rating – LP Fuel		150°C Rise Alternator Standby Rating – Natural Gas		125°C Rise Alternator Prime Rating – Natural Gas	
					kW / kVA	Amps	kW / kVA	Amps	kW / kVA	Amps
IGLC420-2N	UCDI274K-311	208 / 120	3	60	200 / 250	695	243 / 304	844	233 / 291	809
		220 / 127	3	60	250 / 313	821	250 / 313	821	239 / 299	785
		240 / 120 (1)	3	60	200 / 250	602	243 / 304	732	233 / 291	701
		240 / 120 (1)	1	60	175 / 175	729	175 / 175	729	175 / 175	729
		240 / 139	3	60	257 / 321	774	265 / 331	798	250 / 313	753
		380 / 220	3	60	215 / 269	409	215 / 269	409	206 / 258	392
		416 / 240	3	60	200 / 250	347	243 / 304	422	233 / 291	405
		440 / 254	3	60	250 / 313	411	250 / 313	411	239 / 299	392
	480 / 277	3	60	257 / 321	387	265 / 331	399	250 / 313	376	
	UCDI274J-17	600 / 347	3	60	256 / 320	308	262 / 328	316	244 / 305	294
	HCI434F-311	208 / 120	3	60	257 / 321	893	388 / 485	1348	356 / 445	1237
		220 / 127	3	60	257 / 321	844	392 / 490	1287	356 / 445	1169
		240 / 120 (1)	3	60	257 / 321	774	388 / 485	1168	356 / 445	1072
		240 / 120 (1)	1	60	230 / 230	958	230 / 230	958	230 / 230	958
		240 / 139	3	60	258 / 323	777	394 / 493	1186	358 / 448	1078
		380 / 220	3	60	252 / 315	479	344 / 430	654	355 / 444	675
		416 / 240	3	60	257 / 321	446	388 / 485	674	356 / 445	618
		440 / 254	3	60	257 / 321	422	392 / 490	644	356 / 445	585
	480 / 277	3	60	258 / 323	388	394 / 493	593	357 / 446	537	
	HCI434F-17	600 / 347	3	60	259 / 324	312	396 / 495	477	358 / 448	431
	HCI534C-311	208 / 120	3	60	259 / 324	900	395 / 494	1372	358 / 448	1244
220 / 127		3	60	259 / 324	851	396 / 495	1301	358 / 448	1176	
240 / 120 (1)		3	60	259 / 324	780	395 / 494	1189	358 / 448	1078	
240 / 139		3	60	259 / 324	780	396 / 495	1192	359 / 449	1081	
380 / 220		3	60	257 / 321	489	392 / 490	745	357 / 446	679	
416 / 240		3	60	259 / 324	450	395 / 494	686	358 / 448	622	
440 / 254		3	60	259 / 324	425	396 / 495	650	358 / 448	588	
480 / 277	3	60	259 / 324	390	396 / 495	596	359 / 449	540		

NOTES: (1) Alternator connections have two circuits available for low voltage. Available current in each low voltage circuit is equal to high voltage current listed in table. For ratings and voltages not listed above refer to the Genset Selector. Standby ratings do not have an overload capability but can be used for the duration of the utility failure per ISO-3046, DIN6271 and BS5514. Baldor reserves the right to implement specifications or design change without notice.

Engine Application Data

Engine Specifications

Manufacturer	NG Engine
Engine Model #	D219TIC
Engine Type	4 Cycle, 12 Cylinder
Induction System	Turbocharged/ Charge Air Cooled
Displacement, L (in ³)	21.93 (1338)
EPA Emissions Certification	40 CFR Part 60 & 1048
HP at Rated Speed BHP (kW _m) NG	605 (451)
HP at Rated Speed BHP (kW _m) Propane	405 (302)
Rated RPM	1800
Bore and Stroke in (mm)	5.04x5.59 (128x142)
Compression Ratio	10.5:1
Air Filter Type	Dry
Governor Type / Model	Electronic
Governor Manufacturer	EControls
Freq Reg NL to FL	Isochronous
Freq Reg Steady State	+/-0.5%

Engine Lubrication System

Oil Pan Capacity gal (L)	10.6 (40.0)
Oil Capacity w/Filter gal (L)	12.5 (47.1)
Oil Filter Quantity	2
Oil Filter Type	Cartridge
Oil Cooler	Water Cooled
Recommended Oil	15W-40 Low Ash
Oil Press psi (kPa)	20.3 (140)

Engine Cooling System

Genset Max Ambient Temp °F (°C)	122 (50)
Engine Coolant Cap qt (L)	46 (52.3)
Engine + Radiator System Cap qt (L)	256 (291.0)
Water Pump Type	Centrifugal
Coolant Flow gpm (Lpm)	174 (660)
Charge Air Cooler Flow cfm (cmm)	1254 (35.5)
Heat Rejected to Charge Air Cooler @ Rated kW; Btu/min (kW)	3040 (53.5)
Heat Rejected to Radiator @ Rated kW; Btu/min(kW)	25760 (453.0)
Max Restriction of Cooling Air in H ₂ O (kPa)	0.5 (0.124)

Engine Exhaust System

Exhaust Manifold Type	Wet
Exhaust Flow @ Rated kW cfm (cmm)	2995 (84.8)
Exhaust Temp (dry manifold) °F (°C)	1382 (750)
Min Back Pressure in H ₂ O (kPa)	0 (0)
Max Back Pressure in H ₂ O (kPa)	20.4 (5.1)
Exhaust Outlet Diameter in (mm)	3.5 (88.9)
Exhaust Outlet Type	Flange
Exhaust Catalyst	Included

Engine Electrical System

Charging Alternator Volts dc	24
Charging Alternator Amps	45
Grounding Polarity	Negative
Starter Motor Volts dc	24
Battery Recommendations	
Battery Volts dc	24
Min Cold Cranking Amps	900
Quantity Required	2

Ventilation Requirements

Cooling Airflow, scfm (cmm)	40000 (1133)
Combustion Airflow, cfm (cmm)	841 (23.8)
Heat Rejected to Ambient	
From Engine, Btu/min (kW)	3583 (63)
From Alternator, Btu/min (kW)	1672 (29.4)
Recommended Free Area Intake Louver Size, ft ² (m ²)	82.0 (7.62)

Engine Fuel System

Recommended Fuel	
Natural Gas min HHV (Btu/ft ³)	1015
Propane Vapor min HHV (Btu/ft ³)	2650
Fuel Supply Pressure in-H ₂ O (kPa)	7-11 (1.7-2.7)
Fuel Line At Engine	
Supply Line, npt	3

Propane Fuel Consumption – Standby Rating

100% Load cfph (m ³ ph)	1410 (39.9)
75% Load cfph (m ³ ph)	1200 (34.0)
50% Load cfph (m ³ ph)	810 (22.9)
25% Load cfph (m ³ ph)	512 (14.5)

NG Fuel Consumption – Standby Rating

100% Load cfph (m ³ ph)	4230 (119.8)
75% Load cfph (m ³ ph)	3297 (93.4)
50% Load cfph (m ³ ph)	2314 (65.5)
25% Load cfph (m ³ ph)	1410 (39.9)

NG Fuel Consumption – Standby Rating

100% Load cfph (m ³ ph)	3849 (109.0)
75% Load cfph (m ³ ph)	3000 (85.0)
50% Load cfph (m ³ ph)	2106 (59.6)
25% Load cfph (m ³ ph)	1283 (36.3)

Engine Output Deratings - Standby

Rated Temp	77°F
Rated Altitude	325 ft
Max Altitude	10,000 ft
Temperature Derate	-1% / 8° F
Altitude Derate	-3% / 1000 ft

Alternator Specifications

Alternator Type	4-Pole, Rotating Field	Automatic Voltage Regulator	
Exciter Type	Brushless	PMG	MX341, MX321
Excitation System		Voltage Regulation	No Load to Full Load
PMG	Standard	Std Regulator	N/A
Insulation	per NEMA MG1	PMG Regulator	+/- 1%, +/- 0.5%
Material	Class H	Load Acceptance	100% of Rating, One Step
Standby Temp Rise	150°C		
Lead Connection	12 Lead, Reconnectable	Subtransient Reactance	
Stator Pitch	2/3	480V, Per Unit	11%
Amortisseur Winding	Full	TIF (1960 Weighting)	<50
Bearing	Single, Double Shielded	Line Harmonics	5% Maximum
Drive Coupling	Flexible Disk	Motor Starting kVA	30% Max Voltage Dip
Unbalanced Load	20% of Standby Rating	Alt @ 480V SkVA	UCDI274K-311 830 kVA
		Alt @ 480V SkVA	HCI534C-311 1480 kVA

Genset Controller Specifications

Baldor IntelliLite NT Features

- Large back-lit graphical LCD Display
64x128 pixel resolution
- 6 LED Genset Status Indicators
 - Alarm Red LED
 - Not In Auto Red LED
 - Warning Yellow LED
 - Running Green LED
 - Ready / Auto Green LED
 - Supplying Load Green LED
- Sealed Membrane Panel to IP65
- Push Buttons for Simple Control
Start, Stop, Fault Reset, Horn Reset, Mode, Page, and Enter Keys
- Display Metering and Protection
 - Oil Pressure Warning / Shutdown
 - High / Low Coolant Temperature Warning
 - High Coolant Temperature Shutdown
 - Low Coolant Level Shutdown
 - Over Speed Protection
 - Battery Voltage Over / Under Warning
 - Running Hour Meter
 - Generator Under / Over Volts Warn / Shutdown
 - Generator Under / Over Freq Warn / Shutdown
 - Generator Over Current Shutdown
 - Generator Output Metering for V1-V3, I1-I3, Hz, kW, kWh, kVA, kVAh

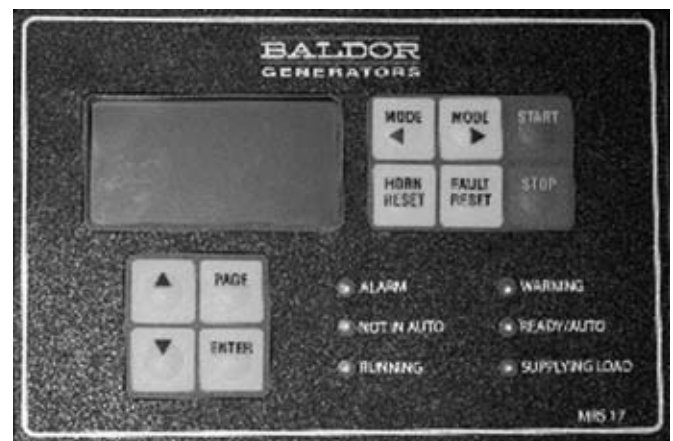

Additional Standard Genset Features

- ✓ Structural Steel Sub-Base
- ✓ Sub-Base Lifting Eyes
- ✓ Unit Mounted Radiator
- ✓ Engine Mounted Fan
- ✓ Radiator Fan Guard
- ✓ Battery Charging Alternator
- ✓ Battery Rack and Cables
- ✓ Unit Mounted Control Panel
- ✓ Spin-On Oil Filter
- ✓ Enamel Finish
- ✓ One Set - Operation / Maintenance Manual
- ✓ Factory Tested Prior to Shipment
- ✓ Limited Warranty

Optional Agency Approvals

- UL2200 (Review Option Availability)
- NFPA110 (Request Remote Annunciator)

Weight and Dimensions (Open Unit)

Weight – Wet lb (kg)	9960 (4518)
Overall Dimensions	Length x Width x Height
inches	162 x 84 x 97
mm	4114 x 2133 x 2463

Note: Drawing is provided for reference only.
Use engineering outline for installation planning.

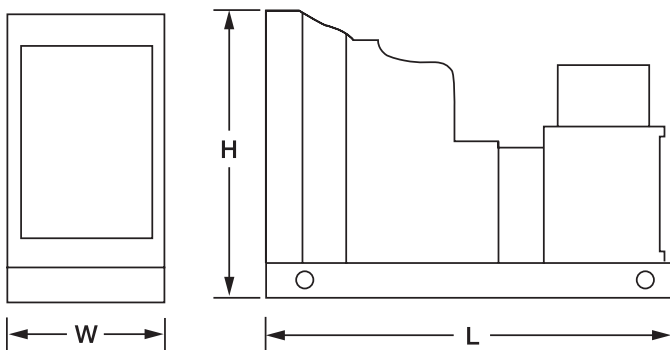

Available Accessories and Options

Open Unit

- Industrial Silencer
- Residential Silencer
- Critical Silencer
- Hospital Grade Silencer
- Exhaust Flex Pipe
- Rain Cap
- Radiator Duct Flange

Enclosed Units

- Weather Resistant Enclosure
- Sound Attenuated w/Internal Critical Silencer
- ISO Container
- Walk-In Enclosure

Alternator Accessories

- AVR Upgrade
- Alternator Space Heater
- Exciter Field Circuit Breaker
- Alternator Drip Shield

Genset Accessories

- Voltage Adjust Potentiometer
- Starting Battery
- Battery Charger Auto/Float
- Auto/ Float Equalize Timer Manual Automatic
- Battery Heater
- Engine Coolant Heater
- Oil & Coolant Drain Valves (Engine/Radiator)
- Oil & Coolant Drain Extended to Base

Main Output Breaker

- Wall Mount
- Unit Mount

Transfer Switch

- Manual
- Automatic

Control Panel

- Remote Annunciator
- Remote Communications
- Remote E-Stop

Fuel System

- Fuel Strainer
- Dual Fuel Automatic Changeover

Vibration Isolators

- Elastomer Isolator
- Standard Spring
- Seismic Spring



Baldor Electric Company • P. O. Box 2400 • Fort Smith, AR 72902-2400 U.S.A.
Phone (479) 646-4711 • Fax (479) 648-5792 • International Fax (479) 648-5895

NATCO BTEX BUSTER

Removes 99.7%* of BTEX and VOC emissions from glycol reconcentrator emissions

The Simple and Cost-effective Answer to Your Emission Compliance Problems

Cameron's NATCO® BTEX BUSTER® provides a removal efficiency greater than 99.7%*, helps recover and collect saleable liquid hydrocarbons and prevents the loss of expensive fuel gas from glycol reconcentrator vent emissions.

The unit is designed using the Environmental Protection Agency-approved Gri-Glycalc computer simulation program with a flash-gas separator in the glycol regeneration process. Under common operating conditions, BTEX (benzene, toluene, ethylbenzene and xylene), as well as other volatile organic compounds (VOCs), are emitted into the atmosphere during the glycol regeneration process. The rates usually are proportional to the glycol circulation rate.

The NATCO BTEX BUSTER captures those hydrocarbon emissions.

Performance

- The cost-effective system is designed to assist operators in reducing BTEX and VOC emissions below the accepted levels and complies with federal and state environmental regulations.
- Economics of the NATCO BTEX BUSTER show that it can pay for itself by recovering saleable hydrocarbon liquids and fuel gas. By condensing troublesome glycol reconcentrator vapors and routing flash gas back to the reconcentrator fuel gas inlet for burning, the unit reduces emissions during glycol plant dehydration processing.
- The NATCO BTEX BUSTER incorporates field-proven burner accessories to help prevent sooting and backpressure on your regeneration system.
- The NATCO BTEX BUSTER also features a design to eliminate potential freeze-up problems when operating in severe cold climates.
- Cameron offers the NATCO BTEX BUSTER in standard sizes to accommodate most customer needs. Our units are backed by Cameron's replacement parts, technical assistance and service available 24 hours a day.



The NATCO BTEX BUSTER cold-weather design eliminates freezing problems associated with cold climates.

How It Works

The NATCO BTEX BUSTER is a relatively simple process that is designed to maintain greater than 99.7%* removal of BTEX and VOC emissions.

The vapors emitted from the glycol still column are cooled in the natural draft air cooler to temperatures below 120° F (49° C).

The condensed liquids are collected in a small two-phase separator and pumped to customer storage. Non-condensable gases from the separator are piped through an in-line flash arrestor and then burned in the glycol reboiler firebox to achieve an overall minimum destruction efficiency of 99.7%* plus.

Features	Benefits
Ideal for Remote Locations	Natural draft self-regulating system does not require any moving pieces of equipment.
Environmentally Correct	Meets Federal Regulation 40 CFR part 63 and meets or exceeds most stringent state regulations LAC 111.2116 and LAC 33:111 chapter 51.
Efficient	Removal efficiency is greater than 99.7%*.
Reduces Operating Costs	Reduces fuel gas consumption and recovers saleable liquid hydrocarbons.
Safe	Features an in-line flash arrestor, high-level switch, pressure safety valve and gas shut-down valves.
Designed for the Oil Field	Includes field-proven burner products, and the pneumatic pump handles aromatic hydrocarbons.
Designed for Cold Weather	Cold-weather design eliminates freezing problems associated with cold climates.
Cameron's Services	Includes experienced staff and worldwide locations, 24 hours a day.

NATCO BTEX BUSTER SKID UNIT

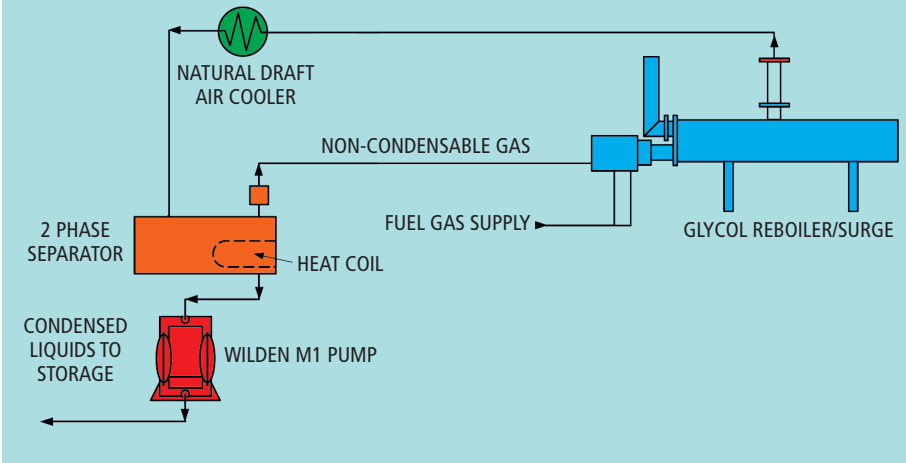

Built-in Safety Features

The NATCO BTEX BUSTER is engineered with proper controls for safe operation and long in-service life. These include an in-line flash arrestor, separator high-level switch, pressure safety valve and gas shut-down valves for high reboiler bath temperatures. It also incorporates field-proven burner accessories that help to prevent typical sooting and backpressures on your regeneration system.

Field-proven, the NATCO BTEX BUSTER now is available through our sales and service locations worldwide.

Standard BTEX Size (1)	Reconcentrator Duty Btu/hr	Glycol Pump gal/hr	Max Capacity water/day (2)	Non-condensable vapor/day (3)	Cooler Duty Btu/hr (3)
150	75,000	40	273	7	30,000
150	150,000	40	273	10	30,000
250	250,000	90	1216	27	51,000
375	375,000	210	1807	45	76,000
550	550,000	210	2650	60	112,000
750	750,000	450	3615	100	152,000

(1) Standard BTEX

Performance of unit is based on a non-condensable vapor HHV greater than 400 Btu/cf and less than 1800 Btu/cf and a glycol circulation rate of no more than 3 gal/lb of water removed.

(2) Maximum Capacity of Water/day

Represents the maximum capacity of water in pounds per day for each of Cameron's standard reboiler size based on a glycol circulation rate of 2 gallons of glycol per pound of water removed.

(3) Non-condensable Vapor/day

Maximum non-condensable vapor rate was calculated with the Gri-Glycalc computer simulation program with a flash-gas separator used in the glycol regeneration process and a BTEX concentration in the inlet gas stream of no more than 700 ppm.

Using adiabatic combustion calculations, a minimum of 99.7%* of these non-condensable vapors are destroyed.

(4) Cooler Duty Btu/hr

Cooler duty was calculated based on a prevailing windspeed of 3 mph and a maximum ambient temperature of 100° F (38° C).

Note: Cameron is not responsible for the disposal of any condensed liquids associated with its BTEX BUSTER units.

* Certain gas streams contain more BTEX and VOCs than represented by Gri-Glycalc. Consult with Cameron's engineers for system evaluation, equipment sizing and application to ensure conversion efficiency.

LOCATIONS

United States of America
11210 Equity Dr., Suite 100
Houston, TX 77041
USA
Tel 713.849.7500

Marcellus/Utica
Laceyville 570.869.3104
Nitro 304.755.9400

Midcontinent
Oklahoma City 405.677.8827

Rockies
Casper 307.234.7183
Bloomfield 505.634.1400
Grand Junction 970.243.3600
Vernal 435.789.1796
Williston 701.774.5500

Texas
Caldwell 979.272.7101
Corpus Christi 361.289.0488
Godley 817.389.2676
Longview 903.759.2738
Odessa 432.530.3600

Canada
Leduc 780.986.9803

Installing Vapor Recovery Units on Storage Tanks



Executive Summary

There are about 500,000 crude oil storage tanks in the United States. These tanks are used to hold oil for brief periods of time in order to stabilize flow between production wells and pipeline or trucking transportation sites. In addition, the condensate liquids contained in produced gas that are captured by a mist eliminator filter/coalescer ahead of the first compressor station in transmission pipelines are often directed to a storage tank as well. During storage, light hydrocarbons dissolved in the crude oil or condensate—including methane and other volatile organic compounds (VOC), natural gas liquids (NGLs), hazardous air pollutants (HAP), and some inert gases—vaporize or "flash out" and collect in the space between the liquid and the fixed roof of the tank. As the liquid level in the tank fluctuates, these vapors are often vented to the atmosphere.

One way to prevent emissions of these light hydrocarbon vapors and yield significant economic savings is to install vapor recovery units (VRUs) on storage tanks. VRUs are relatively simple systems that can capture about 95 percent of the Btu-rich vapors for sale or for use onsite as fuel. Currently, between 7,000 and 9,000 VRUs are installed in the oil production sector, with an average of four tanks connected to each VRU.

Natural Gas STAR partners have generated significant savings from recovering and marketing these vapors while at the same time substantially reducing methane and HAP emissions. Partners have found that when the volume of vapors is sufficient, installing a VRU on one or multiple

storage tanks can save up to \$606,800 per year and payback in as little as two months. This Lessons Learned study describes how partners can identify when and where VRUs should be installed to realize these economic and environmental benefits.

Technology Background

Underground crude oil contains many lighter hydrocarbons in solution. When the oil is brought to the surface and processed, many of the dissolved lighter hydrocarbons (as well as water) are removed through a series of high-pressure and low-pressure separators. The crude oil is then injected into a storage tank to await sale and transportation off site; the remaining hydrocarbons in the oil are emitted as vapors into the tank. The same principles apply for condensate, which accumulates as a result of the conditions within the pipelines and is removed ahead of the first compressor station. The recovered condensate, which contains dissolved light hydrocarbons, is routed to a storage tank where the dissolved light hydrocarbons are emitted as vapors. These vapors are either vented, flared, or recovered by vapor recovery units (VRUs). Losses of the remaining lighter hydrocarbons are categorized in three ways:

- ★ Flash losses occur when the separator or heater treater, operating at approximately 35 pounds per square inch (psi), dumps oil into the storage tanks, which are at atmospheric pressure.
- ★ Working losses refer to the vapor released from the

Economic and Environmental Benefits

Method for Reducing Natural Gas Losses	Volume of Natural Gas Savings (Mcf/yr)	Value of Natural Gas Savings (\$/yr) ¹			Implementation Cost (\$)	Other Costs (\$)	Payback (Months)		
		\$3 per Mcf	\$5 per Mcf	\$7 per Mcf			\$3 per Mcf	\$5 per Mcf	\$7 per Mcf
Installing Vapor Recovery Units (VRUs) on Oil Production Storage Tanks	4,900—96,000	\$13,965— \$273,600	\$23,275— \$456,000	\$32,585— \$638,400	\$35,738— \$103,959	\$7,367— \$16,839	6 — 37	4 — 23	3 — 16

¹ Assumes 95% of the annual volume of gas lost can be recovered using a VRU.

Installing Vapor Recovery Units on Storage Tanks

(Cont'd)

changing fluid levels and agitation of tank contents associated with the circulation of fresh oil through the storage tanks.

- ★ Standing losses occur with daily and seasonal temperature changes.

The volume of gas vapor coming off a storage tank depends on many factors. Lighter crude oils (API gravity > 36°) flash more hydrocarbon vapors than heavier crudes (API gravity < 36°). In storage tanks where the oil is frequently cycled and the overall throughput is high, more “working vapors” will be released than in tanks with low throughput and where the oil is held for longer periods and allowed to “weather.” Finally, the operating temperature and pressure of oil in the vessel dumping into the tank will affect the volume of flashed gases coming out of the oil.

The makeup of these vapors varies, but the largest component is methane (between 40 and 60 percent). Other components include more complex hydrocarbon compounds such as propane, butane, and ethane; natural inert gases such as nitrogen and carbon dioxide; and HAP like benzene, toluene, ethyl-benzene, and xylene (collectively these four HAP are referred to as BTEX).

VRUs can recover over 95 percent of the hydrocarbon

emissions that accumulate in storage tanks. Because recovered vapors contain natural gas liquids (even after condensates have been captured by the suction scrubber), they have a Btu content that is higher than that of pipeline quality natural gas (between 950 and 1,100 Btu per standard cubic foot [scf]). Depending on the volume of NGLs in the vapors, the Btu content can reach as high as 2,000 Btu per scf. Therefore, on a volumetric basis, the recovered vapors can be more valuable than methane alone.

Exhibit 1 illustrates a VRU installed on a single crude oil storage tank (multiple tank installations are also common). Hydrocarbon vapors are drawn out of the storage (stock) tank under low-pressure, typically between four ounces and two psi, and are first piped to a separator (suction scrubber) to collect any liquids that condense out. The liquids are usually recycled back to the storage tank. From the separator, the vapors flow through a compressor that provides the low-pressure suction for the VRU system. (To prevent the creation of a vacuum in the top of a tank when oil is withdrawn and the oil level drops, VRUs are equipped with a control pilot to shut down the compressor and permit the back flow of vapors into the tank.) The vapors are then metered and removed from the VRU system for pipeline sale or onsite fuel supply.

Exhibit 1: Standard Stock Tank Vapor Recovery System

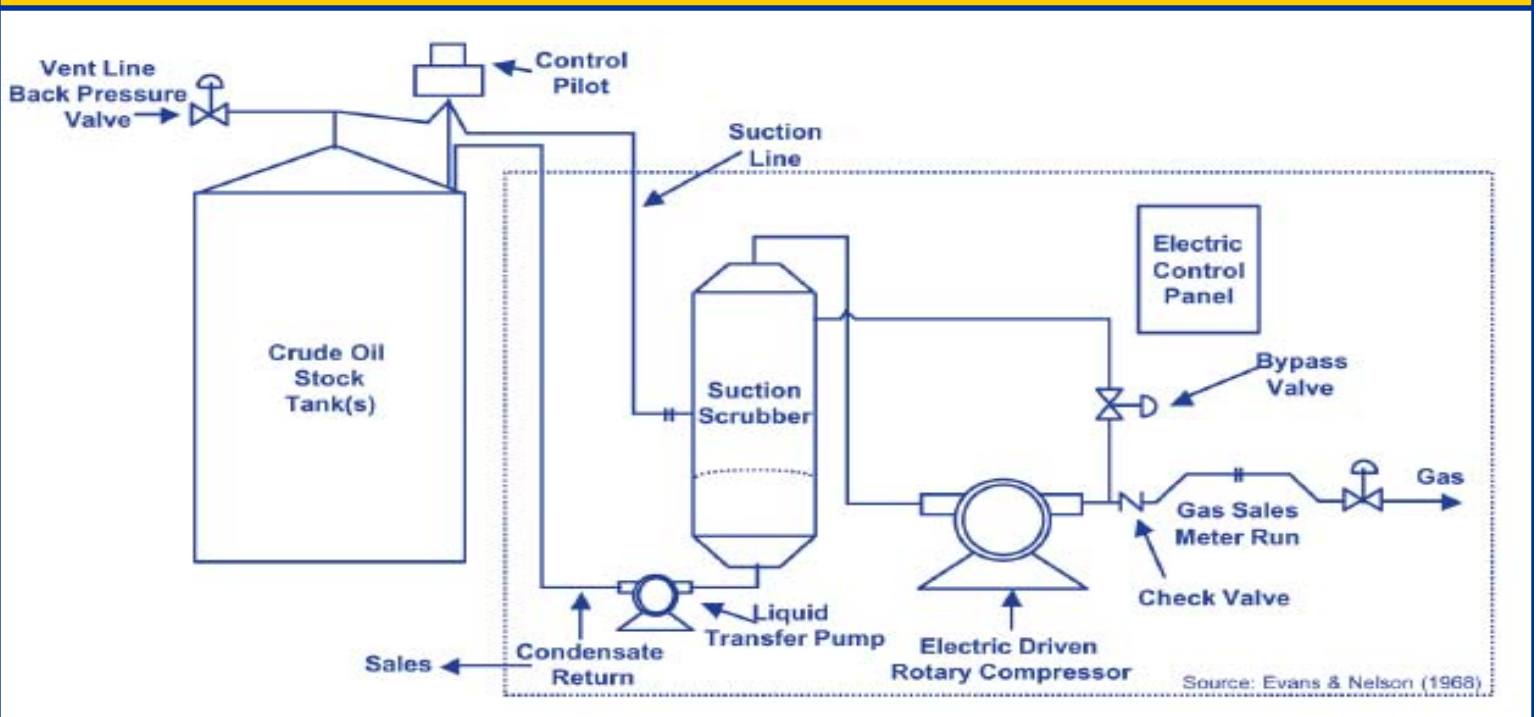

CARBTRON[®]

AIR PURIFICATION CANISTERS 140-200 LB. ACTIVATED CARBON

G-1
G-2
G-3



The CARBTRON "G" Canisters handles flows up to 500 CFM.

FEATURES

- High activity carbon.
- Epoxy lined steel or polyethylene construction.
- Acceptable for transport of hazardous spent carbon.
- Side drain for removal of accumulated condensate.
- Low pressure drop.
- PVC internal piping.
- High temperature (180°F) steel units available.

APPLICATIONS

- Soil vapor remediation
- Air stripper exhausts
- Tank vents
- Exhaust hoods
- Work area purification
- Sewage plant odor control

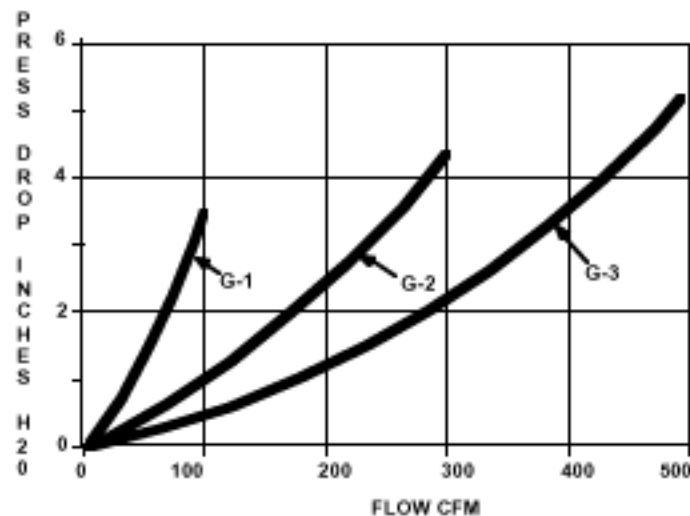

© Copyright 1991 Carbtronic Corporation - 10/4/02

AT-116/81

CARBTRON[®]
CORPORATION

955 Connecticut Ave., Suite 5202
Bridgeport, CT 06607

800-242-1150 Fax: 203-337-4347
www.carbtronic.com info@carbtronic.com

CARBOTROL®

AIR PURIFICATION CANISTERS 140-200 LB. ACTIVATED CARBON

G-1
G-2
G-3

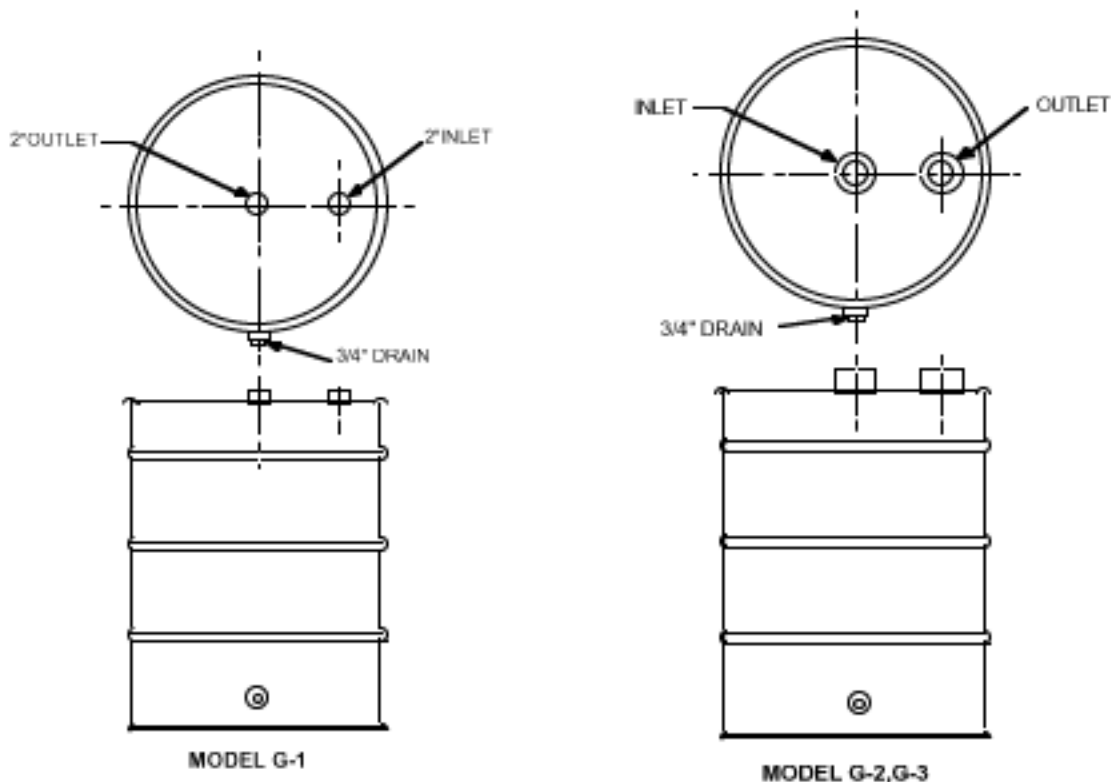

SPECIFICATIONS

<u>MODEL</u>	<u>DIAMETER/HEIGHT</u>	<u>CARBON WEIGHT</u>	<u>INLET/OUTLET</u>	<u>MAXIMUM RATED FLOW</u>	<u>APPROXIMATE SHIP WEIGHT</u>
G-1*	24"/36"	200 lbs.	2"/2"	100 CFM	250 lbs.
G-2*	24"/36"	170 lbs.	4"/4"	300 CFM	220 lbs.
G-3P	24"/36"	140 lbs.	6"/6"	500 CFM	190 lbs.
G-3S	24"/34"	140 lbs.	4"/4"	500 CFM	180 lbs.

* Specify: Polyethylene (P) or Epoxy Lined Steel (S)

SAFETY

Certain chemical compounds in the presence of activated carbon may oxidize, decompose or polymerize. This could result in temperature increases sufficient to cause ignition of the activated carbon or adsorbed material. If a compounds reaction with activated carbon is unknown, appropriate tests should be considered.

CARBOTROL®
CORPORATION

955 Connecticut Ave., Suite 5202
Bridgeport, CT 06607

800-242-1150 Fax: 203-337-4347
www.carbtrol.com info@carbtrol.com

Supplement S3

Emission Program Data

- **EPA Tanks 4.0.9d – Stabilized Condensate (SC) – Tank Emissions**
 - **EPA Tanks 4.0.9d – Produced Water (PW) – Tank Emissions**
 - **GRI-GLYCalc – 55.0 MMscfd Dehydrator**
-

Stabilized Condensate (SC) - Storage Tank (TK1-8)

TANKS 4.0.9d
Emissions Report - Summary Format
Tank Identification and Physical Characteristics

Identification

User Identification: Battle Run CF 400 bbl Stabilized Condensate Tank
 City: Near Dallas
 State: West Virginia
 Company: Appalachia Midstream Services
 Type of Tank: Vertical Fixed Roof Tank
 Description: Each of Eight 400 bbl Stabilized Condensate Tanks. Assume Gasoline RVP=12 as product stored.

Tank Dimensions

Shell Height (ft): 20.00
 Diameter (ft): 12.00
 Liquid Height (ft) : 19.00
 Avg. Liquid Height (ft): 10.00
 Volume (gallons): 16,074.56
 Turnovers: 77.49
 Net Throughput(gal/yr): 1,245,552.00
 Is Tank Heated (y/n): N

Paint Characteristics

Shell Color/Shade: White/White
 Shell Condition: Good
 Roof Color/Shade: White/White
 Roof Condition: Good

Roof Characteristics

Type: Cone
 Height (ft): 0.00
 Slope (ft/ft) (Cone Roof): 0.06

Breather Vent Settings

Vacuum Settings (psig): -0.03
 Pressure Settings (psig): 0.03

Meteorological Data used in Emissions Calculations: Pittsburgh, Pennsylvania (Avg Atmospheric Pressure = 14.11 psia)

TANKS 4.0.9d
Emissions Report - Summary Format
Liquid Contents of Storage Tank

Battle Run CF 400 bbl Stabilized Condensate Tank - Vertical Fixed Roof Tank
Near Dallas, West Virginia

Mixture/Component	Month	Daily Liquid Surf. Temperature (deg F)			Liquid Bulk Temp (deg F)	Vapor Pressure (psia)			Vapor Mol. Weight.	Liquid Mass Fract.	Vapor Mass Fract.	Mol. Weight	Basis for Vapor Pressure Calculations
		Avg.	Min.	Max.		Avg.	Min.	Max.					
Gasoline (RVP 12)	All	51.04	47.08	56.81	50.33	5.4430	4.9447	5.9807	64.0000			92.00	Option 4: RVP=12, ASTM Slope=3

TANKS 4.0.9d
Emissions Report - Summary Format
Individual Tank Emission Totals

Emissions Report for: Annual

Battle Run CF 400 bbl Stabilized Condensate Tank - Vertical Fixed Roof Tank
Near Dallas, West Virginia

Components	Losses(lbs)		
	Working Loss	Breathing Loss	Total Emissions
Gasoline (RVP 12)	5,721.52	1,019.88	6,741.40

Produced Water (PW) - Storage Tank (WTK)

TANKS 4.0.9d
Emissions Report - Summary Format
Tank Identification and Physical Characteristics

Identification

User Identification: Battle Run 400 bbl Produced Water Tank
 City: Near Dallas
 State: West Virginia
 Company: Appalachia Midstream Services
 Type of Tank: Vertical Fixed Roof Tank
 Description: 400 bbl Produced Water Tank. Assume 95% Water + 5% Gasoline RVP=12 as product stored.

Tank Dimensions

Shell Height (ft): 20.00
 Diameter (ft): 12.00
 Liquid Height (ft) : 19.00
 Avg. Liquid Height (ft): 10.00
 Volume (gallons): 16,074.56
 Turnovers: 47.68
 Net Throughput(gal/yr): 766,500.00
 Is Tank Heated (y/n): N

Paint Characteristics

Shell Color/Shade: White/White
 Shell Condition: Good
 Roof Color/Shade: White/White
 Roof Condition: Good

Roof Characteristics

Type: Cone
 Height (ft) 0.00
 Slope (ft/ft) (Cone Roof) 0.06

Breather Vent Settings

Vacuum Settings (psig): -0.03
 Pressure Settings (psig) 0.03

Meteorological Data used in Emissions Calculations: Pittsburgh, Pennsylvania (Avg Atmospheric Pressure = 14.11 psia)

TANKS 4.0.9d
Emissions Report - Summary Format
Liquid Contents of Storage Tank

Battle Run 400 bbl Produced Water Tank - Vertical Fixed Roof Tank
Near Dallas, West Virginia

Mixture/Component	Month	Daily Liquid Surf. Temperature (deg F)			Liquid Bulk Temp (deg F)	Vapor Pressure (psia)			Vapor Mol. Weight	Liquid Mass Fract.	Vapor Mass Fract.	Mol. Weight	Basis for Vapor Pressure Calculations
		Avg.	Min.	Max.		Avg.	Min.	Max.					
Produced Water	All	51.94	47.06	56.81	50.33	0.2465	0.2101	0.2893	28.3522	0.0500	0.5080	18.75	
Gasoline (RVP 12)						5.4430	4.9447	5.9807	64.0000	0.0500	0.5080	92.00	Option 4: RVP=12, ASTM Slope=3
Water						0.1930	0.1614	0.2307	18.0000	0.9500	0.4920	18.00	Option 1: VP50 = .178073 VP60 = .255246

TANKS 4.0.9d
Emissions Report - Summary Format
Individual Tank Emission Totals

Emissions Report for: Annual

Battle Run 400 bbl Produced Water Tank - Vertical Fixed Roof Tank
Near Dallas, West Virginia

Components	Losses(lbs)		
	Working Loss	Breathing Loss	Total Emissions
Produced Water	101.51	18.57	120.08
Water	49.94	9.14	59.08
Gasoline (RVP 12)	51.57	9.44	61.00

GRI-GLYCalc VERSION 4.0 - EMISSIONS SUMMARY

Case Name: BRCS-55.0 Dehy-Electric Pump-010218

File Name: C:\Users\Clyde\Documents\Documents\04.16 - Ecologic\07 - AMS -

000-BRCS-BCS-SHCS-TVOP-122617\BRCS-NSR-CR-FINAL\BRCS-55.0 Dehy-Electric Pump-010218.ddf

Date: December 31, 2017

CONTROLLED REGENERATOR EMISSIONS

Component	lbs/hr	lbs/day	tons/yr
Methane	0.0777	1.865	0.3404
Ethane	0.2846	6.831	1.2466
Propane	0.3849	9.237	1.6858
Isobutane	0.0863	2.071	0.3780
n-Butane	0.3784	9.081	1.6573
Isopentane	0.0841	2.018	0.3683
n-Pentane	0.1692	4.060	0.7409
n-Hexane	0.0896	2.151	0.3926
Cyclohexane	0.1085	2.603	0.4750
Other Hexanes	0.0731	1.754	0.3202
Heptanes	0.0911	2.186	0.3989
Methylcyclohexane	0.0690	1.655	0.3021
2,2,4-Trimethylpentane	0.0007	0.016	0.0030
Benzene	0.0605	1.453	0.2651
Toluene	0.0848	2.034	0.3712
Ethylbenzene	0.0044	0.105	0.0191
Xylenes	0.0358	0.858	0.1566
C8+ Heavies	0.0011	0.026	0.0048
Total Emissions	2.0835	50.005	9.1259
Total Hydrocarbon Emissions	2.0835	50.005	9.1259
Total VOC Emissions	1.7212	41.309	7.5389
Total HAP Emissions	0.2757	6.617	1.2077
Total BTEX Emissions	0.1854	4.449	0.8120

UNCONTROLLED REGENERATOR EMISSIONS

Component	lbs/hr	lbs/day	tons/yr
Methane	1.5550	37.319	6.8108
Ethane	5.7034	136.882	24.9810
Propane	7.7656	186.374	34.0133
Isobutane	1.7563	42.150	7.6924
n-Butane	7.7503	186.007	33.9463
Isopentane	1.7809	42.742	7.8004
n-Pentane	3.6387	87.328	15.9373
n-Hexane	2.1141	50.737	9.2596
Cyclohexane	2.7123	65.096	11.8800
Other Hexanes	1.6537	39.690	7.2434
Heptanes	2.7203	65.288	11.9150
Methylcyclohexane	2.0653	49.566	9.0458
2,2,4-Trimethylpentane	0.0205	0.492	0.0898
Benzene	1.5341	36.819	6.7194
Toluene	3.0692	73.662	13.4433
Ethylbenzene	0.2778	6.667	1.2167
Xylenes	2.5507	61.217	11.1722
C8+ Heavies	3.3291	79.900	14.5817

			Page: 2
Total Emissions	51.9973	1247.936	227.7484
Total Hydrocarbon Emissions	51.9973	1247.936	227.7484
Total VOC Emissions	44.7389	1073.735	195.9566
Total HAP Emissions	9.5664	229.595	41.9010
Total BTEX Emissions	7.4319	178.365	32.5516

FLASH GAS EMISSIONS

Note: Flash Gas Emissions are zero with the Recycle/recompression control option.

FLASH TANK OFF GAS

Component	lbs/hr	lbs/day	tons/yr
Methane	34.3934	825.441	150.6431
Ethane	34.0770	817.848	149.2572
Propane	22.0767	529.841	96.6960
Isobutane	3.2157	77.177	14.0849
n-Butane	10.7353	257.647	47.0206
Isopentane	2.1116	50.678	9.2488
n-Pentane	3.4153	81.967	14.9591
n-Hexane	1.0674	25.617	4.6751
Cyclohexane	0.3306	7.935	1.4481
Other Hexanes	1.1106	26.655	4.8646
Heptanes	0.6453	15.487	2.8265
Methylcyclohexane	0.1927	4.624	0.8439
2,2,4-Trimethylpentane	0.0098	0.235	0.0430
Benzene	0.0262	0.628	0.1146
Toluene	0.0326	0.784	0.1430
Ethylbenzene	0.0017	0.040	0.0073
Xylenes	0.0106	0.253	0.0462
C8+ Heavies	0.0669	1.605	0.2928
Total Emissions	113.5193	2724.463	497.2145
Total Hydrocarbon Emissions	113.5193	2724.463	497.2145
Total VOC Emissions	45.0489	1081.174	197.3142
Total HAP Emissions	1.1482	27.557	5.0291
Total BTEX Emissions	0.0710	1.704	0.3111

COMBINED REGENERATOR VENT/FLASH GAS EMISSIONS

Component	lbs/hr	lbs/day	tons/yr
Methane	0.0777	1.865	0.3404
Ethane	0.2846	6.831	1.2466
Propane	0.3849	9.237	1.6858
Isobutane	0.0863	2.071	0.3780
n-Butane	0.3784	9.081	1.6573
Isopentane	0.0841	2.018	0.3683
n-Pentane	0.1692	4.060	0.7409
n-Hexane	0.0896	2.151	0.3926
Cyclohexane	0.1085	2.603	0.4750
Other Hexanes	0.0731	1.754	0.3202
Heptanes	0.0911	2.186	0.3989
Methylcyclohexane	0.0690	1.655	0.3021

Page: 3

2,2,4-Trimethylpentane	0.0007	0.016	0.0030
Benzene	0.0605	1.453	0.2651
Toluene	0.0848	2.034	0.3712
Ethylbenzene	0.0044	0.105	0.0191
Xylenes	0.0358	0.858	0.1566
C8+ Heavies	0.0011	0.026	0.0048

Total Emissions	2.0835	50.005	9.1259
Total Hydrocarbon Emissions	2.0835	50.005	9.1259
Total VOC Emissions	1.7212	41.309	7.5389
Total HAP Emissions	0.2757	6.617	1.2077
Total BTEX Emissions	0.1854	4.449	0.8120

GRI-GLYCalc VERSION 4.0 - SUMMARY OF INPUT VALUES

Case Name: BRCS-55.0 Dehy-Electric Pump-010218

File Name: C:\Users\Clyde\Documents\Documents\04.16 - Ecologic\07 - AMS -
000-BRCS-BCS-SHCS-TVOP-122617\BRCS-NSR-CR-FINAL\BRCS-55.0 Dehy-Electric Pump-010218.ddf

Date: December 31, 2017

DESCRIPTION:

Description: 55MMscfd, 1.0 MMbtu/hr reboiler
22 gpm Electric Pump
Flash Tank w/ 100% Recycle
BTEX Buster at 120 oF w/ 95% Control

Annual Hours of Operation: 8760.0 hours/yr

WET GAS:

Temperature: 95.00 deg. F
Pressure: 1100.00 psig
Wet Gas Water Content: Saturated

Component	Conc. (vol %)
Carbon Dioxide	0.0911
Nitrogen	0.4871
Methane	72.3724
Ethane	16.4056
Propane	6.5403
Isobutane	0.6839
n-Butane	1.9846
Isopentane	0.3844
n-Pentane	0.5497
n-Hexane	0.1516
Cyclohexane	0.0310
Other Hexanes	0.1663
Heptanes	0.0875
Methylcyclohexane	0.0210
2,2,4-Trimethylpentane	0.0017
Benzene	0.0020
Toluene	0.0028
Ethylbenzene	0.0002
Xylenes	0.0014
C8+ Heavies	0.0354

DRY GAS:

Flow Rate: 55.0 MMSCF/day
Water Content: 7.0 lbs. H2O/MMSCF

LEAN GLYCOL:

Glycol Type: TEG
Water Content: 1.5 wt% H2O
Flow Rate: 22.0 gpm

PUMP:

Glycol Pump Type: Electric/Pneumatic

FLASH TANK:

Flash Control: Recycle/recompression
Temperature: 120.0 deg. F
Pressure: 50.0 psig

REGENERATOR OVERHEADS CONTROL DEVICE:

Control Device: Condenser
Temperature: 120.0 deg. F
Pressure: 14.1 psia

Control Device: Combustion Device
Destruction Efficiency: 95.0 %
Excess Oxygen: 0.0 %
Ambient Air Temperature: 60.0 deg. F

GRI-GLYCalc VERSION 4.0 - AGGREGATE CALCULATIONS REPORT

Case Name: BRCS-55.0 Dehy-Electric Pump-010218

File Name: C:\Users\Clyde\Documents\Documents\04.16 - Ecologic\07 - AMS -
000-BRCS-BCS-SHCS-TVOP-122617\BRCS-NSR-CR-FINAL\BRCS-55.0 Dehy-Electric Pump-010218.ddf

Date: December 31, 2017

DESCRIPTION:

Description: 55MMscfd, 1.0 MMbtu/hr reboiler
22 gpm Electric Pump
Flash Tank w/ 100% Recycle
BTEX Buster at 120 oF w/ 95% Control

Annual Hours of Operation: 8760.0 hours/yr

EMISSIONS REPORTS:

CONTROLLED REGENERATOR EMISSIONS

Component	lbs/hr	lbs/day	tons/yr
Methane	0.0777	1.865	0.3404
Ethane	0.2846	6.831	1.2466
Propane	0.3849	9.237	1.6858
Isobutane	0.0863	2.071	0.3780
n-Butane	0.3784	9.081	1.6573
Isopentane	0.0841	2.018	0.3683
n-Pentane	0.1692	4.060	0.7409
n-Hexane	0.0896	2.151	0.3926
Cyclohexane	0.1085	2.603	0.4750
Other Hexanes	0.0731	1.754	0.3202
Heptanes	0.0911	2.186	0.3989
Methylcyclohexane	0.0690	1.655	0.3021
2,2,4-Trimethylpentane	0.0007	0.016	0.0030
Benzene	0.0605	1.453	0.2651
Toluene	0.0848	2.034	0.3712
Ethylbenzene	0.0044	0.105	0.0191
Xylenes	0.0358	0.858	0.1566
C8+ Heavies	0.0011	0.026	0.0048
Total Emissions	2.0835	50.005	9.1259
Total Hydrocarbon Emissions	2.0835	50.005	9.1259
Total VOC Emissions	1.7212	41.309	7.5389
Total HAP Emissions	0.2757	6.617	1.2077
Total BTEX Emissions	0.1854	4.449	0.8120

UNCONTROLLED REGENERATOR EMISSIONS

Component	lbs/hr	lbs/day	tons/yr
Methane	1.5550	37.319	6.8108
Ethane	5.7034	136.882	24.9810
Propane	7.7656	186.374	34.0133
Isobutane	1.7563	42.150	7.6924
n-Butane	7.7503	186.007	33.9463
Isopentane	1.7809	42.742	7.8004
n-Pentane	3.6387	87.328	15.9373

Page: 2

n-Hexane	2.1141	50.737	9.2596
Cyclohexane	2.7123	65.096	11.8800
Other Hexanes	1.6537	39.690	7.2434
Heptanes	2.7203	65.288	11.9150
Methylcyclohexane	2.0653	49.566	9.0458
2,2,4-Trimethylpentane	0.0205	0.492	0.0898
Benzene	1.5341	36.819	6.7194
Toluene	3.0692	73.662	13.4433
Ethylbenzene	0.2778	6.667	1.2167
Xylenes	2.5507	61.217	11.1722
C8+ Heavies	3.3291	79.900	14.5817

Total Emissions	51.9973	1247.936	227.7484
Total Hydrocarbon Emissions	51.9973	1247.936	227.7484
Total VOC Emissions	44.7389	1073.735	195.9566
Total HAP Emissions	9.5664	229.595	41.9010
Total BTEX Emissions	7.4319	178.365	32.5516

FLASH GAS EMISSIONS

Note: Flash Gas Emissions are zero with the Recycle/recompression control option.

FLASH TANK OFF GAS

Component	lbs/hr	lbs/day	tons/yr
Methane	34.3934	825.441	150.6431
Ethane	34.0770	817.848	149.2572
Propane	22.0767	529.841	96.6960
Isobutane	3.2157	77.177	14.0849
n-Butane	10.7353	257.647	47.0206
Isopentane	2.1116	50.678	9.2488
n-Pentane	3.4153	81.967	14.9591
n-Hexane	1.0674	25.617	4.6751
Cyclohexane	0.3306	7.935	1.4481
Other Hexanes	1.1106	26.655	4.8646
Heptanes	0.6453	15.487	2.8265
Methylcyclohexane	0.1927	4.624	0.8439
2,2,4-Trimethylpentane	0.0098	0.235	0.0430
Benzene	0.0262	0.628	0.1146
Toluene	0.0326	0.784	0.1430
Ethylbenzene	0.0017	0.040	0.0073
Xylenes	0.0106	0.253	0.0462
C8+ Heavies	0.0669	1.605	0.2928

Total Emissions	113.5193	2724.463	497.2145
Total Hydrocarbon Emissions	113.5193	2724.463	497.2145
Total VOC Emissions	45.0489	1081.174	197.3142
Total HAP Emissions	1.1482	27.557	5.0291
Total BTEX Emissions	0.0710	1.704	0.3111

COMBINED REGENERATOR VENT/FLASH GAS EMISSIONS

Component	lbs/hr	lbs/day	tons/yr

Page: 3

Methane	0.0777	1.865	0.3404
Ethane	0.2846	6.831	1.2466
Propane	0.3849	9.237	1.6858
Isobutane	0.0863	2.071	0.3780
n-Butane	0.3784	9.081	1.6573
Isopentane	0.0841	2.018	0.3683
n-Pentane	0.1692	4.060	0.7409
n-Hexane	0.0896	2.151	0.3926
Cyclohexane	0.1085	2.603	0.4750
Other Hexanes	0.0731	1.754	0.3202
Heptanes	0.0911	2.186	0.3989
Methylcyclohexane	0.0690	1.655	0.3021
2,2,4-Trimethylpentane	0.0007	0.016	0.0030
Benzene	0.0605	1.453	0.2651
Toluene	0.0848	2.034	0.3712
Ethylbenzene	0.0044	0.105	0.0191
Xylenes	0.0358	0.858	0.1566
C8+ Heavies	0.0011	0.026	0.0048

Total Emissions	2.0835	50.005	9.1259
Total Hydrocarbon Emissions	2.0835	50.005	9.1259
Total VOC Emissions	1.7212	41.309	7.5389
Total HAP Emissions	0.2757	6.617	1.2077
Total BTEX Emissions	0.1854	4.449	0.8120

COMBINED REGENERATOR VENT/FLASH GAS EMISSION CONTROL REPORT:

Component	Uncontrolled tons/yr	Controlled tons/yr	% Reduction
Methane	157.4538	0.3404	99.78
Ethane	174.2383	1.2466	99.28
Propane	130.7093	1.6858	98.71
Isobutane	21.7773	0.3780	98.26
n-Butane	80.9669	1.6573	97.95
Isopentane	17.0492	0.3683	97.84
n-Pentane	30.8964	0.7409	97.60
n-Hexane	13.9346	0.3926	97.18
Cyclohexane	13.3281	0.4750	96.44
Other Hexanes	12.1079	0.3202	97.36
Heptanes	14.7415	0.3989	97.29
Methylcyclohexane	9.8897	0.3021	96.95
2,2,4-Trimethylpentane	0.1328	0.0030	97.74
Benzene	6.8340	0.2651	96.12
Toluene	13.5863	0.3712	97.27
Ethylbenzene	1.2240	0.0191	98.44
Xylenes	11.2184	0.1566	98.60
C8+ Heavies	14.8745	0.0048	99.97

Total Emissions	724.9629	9.1259	98.74
Total Hydrocarbon Emissions	724.9629	9.1259	98.74
Total VOC Emissions	393.2708	7.5389	98.08
Total HAP Emissions	46.9301	1.2077	97.43
Total BTEX Emissions	32.8627	0.8120	97.53

EQUIPMENT REPORTS:

CONDENSER AND COMBUSTION DEVICE

Condenser Outlet Temperature: 120.00 deg. F
 Condenser Pressure: 14.08 psia
 Condenser Duty: 1.67e-001 MM BTU/hr
 Hydrocarbon Recovery: 0.83 bbls/day
 Produced Water: 7.06 bbls/day
 Ambient Temperature: 60.00 deg. F
 Excess Oxygen: 0.00 %
 Combustion Efficiency: 95.00 %
 Supplemental Fuel Requirement: 1.67e-001 MM BTU/hr

Component	Emitted	Destroyed
Methane	5.00%	95.00%
Ethane	4.99%	95.01%
Propane	4.96%	95.04%
Isobutane	4.91%	95.09%
n-Butane	4.88%	95.12%
Isopentane	4.72%	95.28%
n-Pentane	4.65%	95.35%
n-Hexane	4.24%	95.76%
Cyclohexane	4.00%	96.00%
Other Hexanes	4.42%	95.58%
Heptanes	3.35%	96.65%
Methylcyclohexane	3.34%	96.66%
2,2,4-Trimethylpentane	3.35%	96.65%
Benzene	3.95%	96.05%
Toluene	2.76%	97.24%
Ethylbenzene	1.57%	98.43%
Xylenes	1.40%	98.60%
C8+ Heavies	0.03%	99.97%

ABSORBER

NOTE: Because the Calculated Absorber Stages was below the minimum allowed, GRI-GLYCalc has set the number of Absorber Stages to 1.25 and has calculated a revised Dry Gas Dew Point.

Calculated Absorber Stages: 1.25
 Calculated Dry Gas Dew Point: 1.87 lbs. H2O/MMSCF

Temperature: 95.0 deg. F
 Pressure: 1100.0 psig
 Dry Gas Flow Rate: 55.0000 MMSCF/day
 Glycol Losses with Dry Gas: 2.3192 lb/hr
 Wet Gas Water Content: Saturated
 Calculated Wet Gas Water Content: 47.68 lbs. H2O/MMSCF
 Calculated Lean Glycol Recirc. Ratio: 12.57 gal/lb H2O

Component	Remaining in Dry Gas	Absorbed in Glycol
Water	3.91%	96.09%
Carbon Dioxide	99.37%	0.63%
Nitrogen	99.94%	0.06%
Methane	99.95%	0.05%

Ethane	99.87%	0.13%
Propane	99.83%	0.17%
Isobutane	99.79%	0.21%
n-Butane	99.73%	0.27%
Isopentane	99.77%	0.23%
n-Pentane	99.71%	0.29%
n-Hexane	99.60%	0.40%
Cyclohexane	98.07%	1.93%
Other Hexanes	99.68%	0.32%
Heptanes	99.37%	0.63%
Methylcyclohexane	98.19%	1.81%
2,2,4-Trimethylpentane	99.74%	0.26%
Benzene	83.48%	16.52%
Toluene	80.11%	19.89%
Ethylbenzene	78.23%	21.77%
Xylenes	71.49%	28.51%
C8+ Heavies	99.07%	0.93%

FLASH TANK

Flash Control: Recycle/recompression
 Flash Temperature: 120.0 deg. F
 Flash Pressure: 50.0 psig

Component	Left in Glycol	Removed in Flash Gas
Water	99.96%	0.04%
Carbon Dioxide	35.96%	64.04%
Nitrogen	4.23%	95.77%
Methane	4.33%	95.67%
Ethane	14.34%	85.66%
Propane	26.02%	73.98%
Isobutane	35.32%	64.68%
n-Butane	41.93%	58.07%
Isopentane	46.02%	53.98%
n-Pentane	51.82%	48.18%
n-Hexane	66.62%	33.38%
Cyclohexane	89.48%	10.52%
Other Hexanes	60.22%	39.78%
Heptanes	80.92%	19.08%
Methylcyclohexane	91.81%	8.19%
2,2,4-Trimethylpentane	68.12%	31.88%
Benzene	98.41%	1.59%
Toluene	99.03%	0.97%
Ethylbenzene	99.47%	0.53%
Xylenes	99.64%	0.36%
C8+ Heavies	98.27%	1.73%

REGENERATOR

No Stripping Gas used in regenerator.

Component	Remaining in Glycol	Distilled Overhead
-----------	---------------------	--------------------

Water	63.87%	36.13%
Carbon Dioxide	0.00%	100.00%
Nitrogen	0.00%	100.00%
Methane	0.00%	100.00%
Ethane	0.00%	100.00%
Propane	0.00%	100.00%
Isobutane	0.00%	100.00%
n-Butane	0.00%	100.00%
Isopentane	1.09%	98.91%
n-Pentane	0.96%	99.04%
n-Hexane	0.75%	99.25%
Cyclohexane	3.58%	96.42%
Other Hexanes	1.66%	98.34%
Heptanes	0.62%	99.38%
Methylcyclohexane	4.36%	95.64%
2,2,4-Trimethylpentane	2.20%	97.80%
Benzene	5.08%	94.92%
Toluene	7.98%	92.02%
Ethylbenzene	10.46%	89.54%
Xylenes	12.96%	87.04%
C8+ Heavies	12.22%	87.78%

STREAM REPORTS:

WET GAS STREAM

Temperature: 95.00 deg. F
 Pressure: 1114.70 psia
 Flow Rate: 2.30e+006 scfh

Component	Conc. (vol%)	Loading (lb/hr)
Water	1.00e-001	1.09e+002
Carbon Dioxide	9.10e-002	2.42e+002
Nitrogen	4.87e-001	8.25e+002
Methane	7.23e+001	7.02e+004
Ethane	1.64e+001	2.98e+004
Propane	6.53e+000	1.74e+004
Isobutane	6.83e-001	2.40e+003
n-Butane	1.98e+000	6.97e+003
Isopentane	3.84e-001	1.68e+003
n-Pentane	5.49e-001	2.40e+003
n-Hexane	1.51e-001	7.90e+002
Cyclohexane	3.10e-002	1.58e+002
Other Hexanes	1.66e-001	8.66e+002
Heptanes	8.74e-002	5.30e+002
Methylcyclohexane	2.10e-002	1.25e+002
2,2,4-Trimethylpentane	1.70e-003	1.17e+001
Benzene	2.00e-003	9.44e+000
Toluene	2.80e-003	1.56e+001
Ethylbenzene	2.00e-004	1.28e+000
Xylenes	1.40e-003	8.98e+000
C8+ Heavies	3.54e-002	3.64e+002
Total Components	100.00	1.35e+005

DRY GAS STREAM

 Temperature: 95.00 deg. F
 Pressure: 1114.70 psia
 Flow Rate: 2.29e+006 scfh

Component	Conc. (vol%)	Loading (lb/hr)
-----	-----	-----
Water	3.94e-003	4.28e+000
Carbon Dioxide	9.06e-002	2.41e+002
Nitrogen	4.87e-001	8.24e+002
Methane	7.24e+001	7.01e+004
Ethane	1.64e+001	2.98e+004
Propane	6.53e+000	1.74e+004
Isobutane	6.83e-001	2.40e+003
n-Butane	1.98e+000	6.95e+003
Isopentane	3.84e-001	1.67e+003
n-Pentane	5.49e-001	2.39e+003
n-Hexane	1.51e-001	7.87e+002
Cyclohexane	3.04e-002	1.55e+002
Other Hexanes	1.66e-001	8.64e+002
Heptanes	8.70e-002	5.27e+002
Methylcyclohexane	2.06e-002	1.22e+002
2,2,4-Trimethylpentane	1.70e-003	1.17e+001
Benzene	1.67e-003	7.88e+000
Toluene	2.24e-003	1.25e+001
Ethylbenzene	1.57e-004	1.00e+000
Xylenes	1.00e-003	6.42e+000
C8+ Heavies	3.51e-002	3.61e+002
-----	-----	-----
Total Components	100.00	1.35e+005

LEAN GLYCOL STREAM

 Temperature: 95.00 deg. F
 Flow Rate: 2.20e+001 gpm

Component	Conc. (wt%)	Loading (lb/hr)
-----	-----	-----
TEG	9.85e+001	1.22e+004
Water	1.50e+000	1.86e+002
Carbon Dioxide	1.23e-012	1.52e-010
Nitrogen	4.25e-013	5.26e-011
Methane	9.75e-018	1.21e-015
Ethane	1.52e-007	1.88e-005
Propane	9.80e-009	1.21e-006
Isobutane	1.20e-009	1.49e-007
n-Butane	3.70e-009	4.58e-007
Isopentane	1.58e-004	1.96e-002
n-Pentane	2.86e-004	3.54e-002
n-Hexane	1.29e-004	1.60e-002
Cyclohexane	8.12e-004	1.01e-001
Other Hexanes	2.25e-004	2.79e-002
Heptanes	1.37e-004	1.69e-002
Methylcyclohexane	7.59e-004	9.41e-002
2,2,4-Trimethylpentane	3.73e-006	4.62e-004

Benzene	6.63e-004	8.21e-002
Toluene	2.15e-003	2.66e-001
Ethylbenzene	2.62e-004	3.25e-002
Xylenes	3.07e-003	3.80e-001
C8+ Heavies	3.74e-003	4.63e-001

Total Components	100.00	1.24e+004

RICH GLYCOL STREAM

 Temperature: 95.00 deg. F
 Pressure: 1114.70 psia
 Flow Rate: 2.26e+001 gpm
 NOTE: Stream has more than one phase.

Component	Conc. (wt%)	Loading (lb/hr)

TEG	9.64e+001	1.22e+004
Water	2.30e+000	2.91e+002
Carbon Dioxide	1.20e-002	1.52e+000
Nitrogen	4.17e-003	5.28e-001
Methane	2.84e-001	3.59e+001
Ethane	3.14e-001	3.98e+001
Propane	2.36e-001	2.98e+001
Isobutane	3.93e-002	4.97e+000
n-Butane	1.46e-001	1.85e+001
Isopentane	3.09e-002	3.91e+000
n-Pentane	5.60e-002	7.09e+000
n-Hexane	2.53e-002	3.20e+000
Cyclohexane	2.48e-002	3.14e+000
Other Hexanes	2.21e-002	2.79e+000
Heptanes	2.67e-002	3.38e+000
Methylcyclohexane	1.86e-002	2.35e+000
2,2,4-Trimethylpentane	2.43e-004	3.08e-002
Benzene	1.30e-002	1.64e+000
Toluene	2.66e-002	3.37e+000
Ethylbenzene	2.46e-003	3.12e-001
Xylenes	2.32e-002	2.94e+000
C8+ Heavies	3.05e-002	3.86e+000

Total Components	100.00	1.27e+004

FLASH TANK OFF GAS STREAM

 Temperature: 120.00 deg. F
 Pressure: 64.70 psia
 Flow Rate: 1.59e+003 scfh

Component	Conc. (vol%)	Loading (lb/hr)

Water	1.42e-001	1.07e-001
Carbon Dioxide	5.30e-001	9.75e-001
Nitrogen	4.32e-001	5.05e-001
Methane	5.13e+001	3.44e+001
Ethane	2.71e+001	3.41e+001
Propane	1.20e+001	2.21e+001
Isobutane	1.32e+000	3.22e+000
n-Butane	4.42e+000	1.07e+001

Isopentane	7.00e-001	2.11e+000
n-Pentane	1.13e+000	3.42e+000
n-Hexane	2.96e-001	1.07e+000
Cyclohexane	9.40e-002	3.31e-001
Other Hexanes	3.08e-001	1.11e+000
Heptanes	1.54e-001	6.45e-001
Methylcyclohexane	4.69e-002	1.93e-001
2,2,4-Trimethylpentane	2.05e-003	9.81e-003
Benzene	8.01e-003	2.62e-002
Toluene	8.48e-003	3.26e-002
Ethylbenzene	3.73e-004	1.66e-003
Xylenes	2.38e-003	1.06e-002
C8+ Heavies	9.39e-003	6.69e-002

Total Components	100.00	1.15e+002

FLASH TANK GLYCOL STREAM

Temperature: 120.00 deg. F
Flow Rate: 2.23e+001 gpm

Component	Conc. (wt%)	Loading (lb/hr)
TEG	9.72e+001	1.22e+004
Water	2.32e+000	2.91e+002
Carbon Dioxide	4.37e-003	5.48e-001
Nitrogen	1.78e-004	2.23e-002
Methane	1.24e-002	1.55e+000
Ethane	4.55e-002	5.70e+000
Propane	6.19e-002	7.77e+000
Isobutane	1.40e-002	1.76e+000
n-Butane	6.18e-002	7.75e+000
Isopentane	1.44e-002	1.80e+000
n-Pentane	2.93e-002	3.67e+000
n-Hexane	1.70e-002	2.13e+000
Cyclohexane	2.24e-002	2.81e+000
Other Hexanes	1.34e-002	1.68e+000
Heptanes	2.18e-002	2.74e+000
Methylcyclohexane	1.72e-002	2.16e+000
2,2,4-Trimethylpentane	1.67e-004	2.10e-002
Benzene	1.29e-002	1.62e+000
Toluene	2.66e-002	3.34e+000
Ethylbenzene	2.47e-003	3.10e-001
Xylenes	2.34e-002	2.93e+000
C8+ Heavies	3.02e-002	3.79e+000

Total Components	100.00	1.25e+004

FLASH GAS EMISSIONS

Control Method: Recycle/recompression
Control Efficiency: 100.00

Note: Flash Gas Emissions are zero with the
Recycle/recompression control option.

REGENERATOR OVERHEADS STREAM

Temperature: 212.00 deg. F
 Pressure: 14.70 psia
 Flow Rate: 2.57e+003 scfh

Component	Conc. (vol%)	Loading (lb/hr)
Water	8.61e+001	1.05e+002
Carbon Dioxide	1.84e-001	5.48e-001
Nitrogen	1.18e-002	2.23e-002
Methane	1.43e+000	1.55e+000
Ethane	2.80e+000	5.70e+000
Propane	2.60e+000	7.77e+000
Isobutane	4.46e-001	1.76e+000
n-Butane	1.97e+000	7.75e+000
Isopentane	3.64e-001	1.78e+000
n-Pentane	7.45e-001	3.64e+000
n-Hexane	3.62e-001	2.11e+000
Cyclohexane	4.76e-001	2.71e+000
Other Hexanes	2.83e-001	1.65e+000
Heptanes	4.01e-001	2.72e+000
Methylcyclohexane	3.11e-001	2.07e+000
2,2,4-Trimethylpentane	2.65e-003	2.05e-002
Benzene	2.90e-001	1.53e+000
Toluene	4.92e-001	3.07e+000
Ethylbenzene	3.86e-002	2.78e-001
Xylenes	3.55e-001	2.55e+000
C8+ Heavies	2.89e-001	3.33e+000
Total Components	100.00	1.58e+002

CONDENSER PRODUCED WATER STREAM

Temperature: 120.00 deg. F
 Flow Rate: 2.06e-001 gpm

Component	Conc. (wt%)	Loading (lb/hr)	(ppm)
Water	1.00e+002	1.03e+002	999675.
Carbon Dioxide	1.09e-003	1.12e-003	11.
Nitrogen	1.16e-006	1.20e-006	0.
Methane	1.56e-004	1.61e-004	2.
Ethane	6.49e-004	6.68e-004	6.
Propane	9.00e-004	9.28e-004	9.
Isobutane	1.10e-004	1.13e-004	1.
n-Butane	6.38e-004	6.58e-004	6.
Isopentane	9.99e-005	1.03e-004	1.
n-Pentane	2.16e-004	2.22e-004	2.
n-Hexane	9.46e-005	9.75e-005	1.
Cyclohexane	6.47e-004	6.67e-004	6.
Other Hexanes	6.22e-005	6.41e-005	1.
Heptanes	5.32e-005	5.48e-005	1.
Methylcyclohexane	1.96e-004	2.02e-004	2.
2,2,4-Trimethylpentane	2.68e-007	2.76e-007	0.
Benzene	1.02e-002	1.05e-002	102.
Toluene	1.17e-002	1.21e-002	117.
Ethylbenzene	4.54e-004	4.68e-004	5.
Xylenes	5.17e-003	5.32e-003	52.

C8+ Heavies	4.03e-007	4.16e-007	0.

Total Components	100.00	1.03e+002	1000000.

CONDENSER RECOVERED OIL STREAM

Temperature: 120.00 deg. F

Flow Rate: 2.42e-002 gpm

Component	Conc. (wt%)	Loading (lb/hr)

Water	3.30e-002	3.40e-003
Carbon Dioxide	4.50e-003	4.63e-004
Nitrogen	4.37e-005	4.50e-006
Methane	5.19e-003	5.34e-004
Ethane	1.03e-001	1.06e-002
Propane	6.52e-001	6.72e-002
Isobutane	2.92e-001	3.01e-002
n-Butane	1.77e+000	1.82e-001
Isopentane	9.62e-001	9.91e-002
n-Pentane	2.48e+000	2.55e-001
n-Hexane	3.12e+000	3.21e-001
Cyclohexane	5.27e+000	5.43e-001
Other Hexanes	1.86e+000	1.92e-001
Heptanes	8.73e+000	8.99e-001
Methylcyclohexane	6.66e+000	6.86e-001
2,2,4-Trimethylpentane	6.59e-002	6.79e-003
Benzene	3.04e+000	3.13e-001
Toluene	1.32e+001	1.36e+000
Ethylbenzene	1.85e+000	1.90e-001
Xylenes	1.78e+001	1.83e+000
C8+ Heavies	3.21e+001	3.31e+000

Total Components	100.00	1.03e+001

CONDENSER VENT STREAM

Temperature: 120.00 deg. F

Pressure: 14.08 psia

Flow Rate: 3.63e+002 scfh

Component	Conc. (vol%)	Loading (lb/hr)

Water	1.21e+001	2.08e+000
Carbon Dioxide	1.30e+000	5.46e-001
Nitrogen	8.32e-002	2.23e-002
Methane	1.01e+001	1.55e+000
Ethane	1.98e+001	5.69e+000
Propane	1.82e+001	7.70e+000
Isobutane	3.10e+000	1.73e+000
n-Butane	1.36e+001	7.57e+000
Isopentane	2.44e+000	1.68e+000
n-Pentane	4.90e+000	3.38e+000
n-Hexane	2.17e+000	1.79e+000
Cyclohexane	2.69e+000	2.17e+000
Other Hexanes	1.77e+000	1.46e+000
Heptanes	1.90e+000	1.82e+000

Methylcyclohexane	1.47e+000	1.38e+000
2,2,4-Trimethylpentane	1.25e-002	1.37e-002
Benzene	1.62e+000	1.21e+000
Toluene	1.92e+000	1.70e+000
Ethylbenzene	8.58e-002	8.72e-002
Xylenes	7.04e-001	7.15e-001
C8+ Heavies	1.35e-002	2.21e-002

Total Components	100.00	4.43e+001

COMBUSTION DEVICE OFF GAS STREAM

Temperature: 1000.00 deg. F
 Pressure: 14.70 psia
 Flow Rate: 1.57e+001 scfh

Component	Conc. (vol%)	Loading (lb/hr)

Methane	1.17e+001	7.77e-002
Ethane	2.29e+001	2.85e-001
Propane	2.11e+001	3.85e-001
Isobutane	3.59e+000	8.63e-002
n-Butane	1.57e+001	3.78e-001
Isopentane	2.81e+000	8.41e-002
n-Pentane	5.66e+000	1.69e-001
n-Hexane	2.51e+000	8.96e-002
Cyclohexane	3.11e+000	1.08e-001
Other Hexanes	2.05e+000	7.31e-002
Heptanes	2.19e+000	9.11e-002
Methylcyclohexane	1.70e+000	6.90e-002
2,2,4-Trimethylpentane	1.45e-002	6.86e-004
Benzene	1.87e+000	6.05e-002
Toluene	2.22e+000	8.48e-002
Ethylbenzene	9.91e-002	4.36e-003
Xylenes	8.13e-001	3.58e-002
C8+ Heavies	1.56e-002	1.10e-003

Total Components	100.00	2.08e+000

Supplement S4
AP-42 / EPA Emission Factors

- **AP-42 – Combustion Emission Factor Summary**
 - **EPA Protocol for Equipment Leak Emission Estimates**
-

Potentially Applicable
AP-42 and GHG EMISSION FACTORS
(Preferentially use test data or vendor data where available)

Pollutant		GAS-FIRED ENGINES			GAS-FIRED TURBINES		
		AP-42 Table 3.2-1; 3.2-2; 3.2-3 07/00			AP-42 Table 3.1-1; 3.1-2a; 3.1-3 04/00		
		2SLB lb/MMBtu	4SLB lb/MMBtu	4SRB lb/MMBtu	Uncontrolled lb/MMBtu	Water Injection lb/MMBtu	Lean Pre-Mix# lb/MMBtu
CRITERIA	NOX (≥ 90% Load)	3.17E+00	4.08E+00	2.21E+00	3.23E-01	1.28E-01	9.91E-02
	CO (≥ 90% Load)	3.86E-01	3.17E-01	3.72E+00	8.23E-02	2.95E-02	1.51E-02
	VOC (NMNEHC w/o HCHO)	4.68E-02	4.92E-02	6.20E-04	2.06E-03	2.06E-03	2.06E-03
	VOC (NMNEHC w/ HCHO)	1.20E-01	1.18E-01	2.96E-02	2.82E-03	2.82E-03	2.13E-03
	PM10/2.5 (Total)	4.83E-02	9.99E-03	1.94E-02	6.63E-03	6.63E-03	6.63E-03
	SO2 (2,000 gr-S/MMscf ≈ 0.0007 W%)	5.88E-04	5.88E-04	5.88E-04	5.88E-04	5.88E-04	5.88E-04
HAPs	Acetaldehyde	7.76E-03	8.36E-03	2.79E-03	4.00E-05	4.00E-05	4.00E-05
	Acrolein	7.78E-03	5.14E-03	2.63E-03	6.40E-06	6.40E-06	6.40E-06
	Benzene	1.94E-03	4.40E-04	1.58E-03	1.20E-05	1.20E-05	9.10E-07
	Butadiene, 1,3-	8.20E-04	2.67E-04	6.63E-04	4.30E-07	4.30E-07	4.30E-07
	Ethylbenzene	1.08E-04	3.97E-05	2.48E-05	3.20E-05	3.20E-05	3.20E-05
	Formaldehyde (HCHO)	5.52E-02	5.28E-02	2.05E-02	7.10E-04	7.10E-04	2.00E-05
	n-Hexane	4.45E-04	1.11E-03	---	---	---	---
	Methanol (MeOH)	2.48E-03	2.50E-03	3.06E-03	---	---	---
	Polycyclic Organic Matter (POM/PAH)	1.34E-04	3.47E-04	9.71E-05	3.25E-05	3.25E-05	3.25E-05
	Toluene	9.63E-04	4.08E-04	5.58E-04	1.30E-04	1.30E-04	1.30E-04
	Trimethylpentane, 2,2,4- (i-Octane)	8.46E-04	2.50E-04	---	---	---	---
	Xylenes	2.68E-04	1.84E-04	1.95E-04	6.40E-05	6.40E-05	6.40E-05
	Other/Trace HAP*	6.57E-04	3.21E-04	1.79E-04	2.90E-05	2.90E-05	2.90E-05
TOTAL HAP	7.94E-02	7.22E-02	3.23E-02	1.06E-03	1.06E-03	3.55E-04	
GHG	CO2 (GWP=1)	1.10E+02	1.10E+02	1.10E+02	1.10E+02	1.10E+02	1.10E+02
	CH4 (GWP=25)	1.45E+00	1.25E+00	2.30E-01	8.64E-03	8.64E-03	8.64E-03
	N2O (GWP=298)	2.20E-04	2.20E-04	2.20E-04	3.00E-03	3.00E-03	3.00E-03
	CO2e	1.46E+02	1.41E+02	1.16E+02	1.11E+02	1.11E+02	1.11E+02

(#Lean Pre-Mix - aka: Dry Low Emissions (DLE or DLN) or SoLoNOx)

Pollutant		GAS-FIRED EXTERNAL COMBUSTION			FLARE	DIESEL ENGINES	DIESEL EMGEN
		AP-42 Table 1.4-1; 1.4-2; 1.4-3 (<100 MMBtu/hr) 07/98			13.5-1 06/17	3.3-1; 3.3-2 10/96	Tier 4 ≥ 751 bhp
		Uncontrolled lb/MMBtu	LoNOx Burners lb/MMBtu	Flue Gas Recirc lb/MMBtu	Combustion lb/MMBtu	Uncontrolled lb/MMBtu	Controlled lb/MMBtu
CRITERIA	NOX (≥ 90% Load)	9.80E-02	4.90E-02	3.14E-02	External Comb.	4.41E+00	4.18E+00
	CO (≥ 90% Load)	8.24E-02	8.24E-02	8.24E-02	3.10E-01	9.50E-01	2.35E+00
	VOC (NMNEHC w/o HCHO)	5.32E-03	5.32E-03	5.32E-03	98% Control	3.52E-01	1.27E-01
	VOC (NMNEHC w/ HCHO)	5.39E-03	5.39E-03	5.39E-03	98% Control	3.53E-01	1.28E-01
	PM10/2.5 (Total)	7.45E-03	7.45E-03	7.45E-03	External Comb.	3.10E-01	1.35E-01
	SO2 (2,000 gr-S/MMscf ≈ 0.0007 W%)	5.88E-04	5.88E-04	5.88E-04	External Comb.	2.90E-01	2.90E-01
HAPs	Acetaldehyde	---	---	---	Use External Combustion or 98% Control, As Appropriate	7.67E-04	2.77E-04
	Acrolein	---	---	---		9.25E-05	3.35E-05
	Benzene	2.06E-06	2.06E-06	2.06E-06		9.33E-04	3.38E-04
	Butadiene, 1,3-	---	---	---		3.91E-05	1.41E-05
	Ethylbenzene	---	---	---		---	---
	Formaldehyde (HCHO)	7.35E-05	7.35E-05	7.35E-05		1.18E-03	4.27E-04
	n-Hexane	1.76E-03	1.76E-03	1.76E-03		---	---
	Methanol (MeOH)	---	---	---		---	---
	Polycyclic Organic Matter (POM/PAH)	6.85E-07	6.85E-07	6.85E-07		1.68E-04	6.08E-05
	Toluene	3.33E-06	3.33E-06	3.33E-06		4.09E-04	1.48E-04
	Trimethylpentane, 2,2,4- (i-Octane)	---	---	---		---	---
Xylenes	---	---	---	2.85E-04	1.03E-04		
Other/Trace HAP*	1.18E-06	1.18E-06	1.18E-06	---	---		
TOTAL HAP	1.85E-03	1.85E-03	1.85E-03	3.87E-03	1.40E-03		
GHG	CO2 (GWP=1)	1.18E+02	1.18E+02	1.18E+02	1.64E+02	1.64E+02	
	CH4 (GWP=25)	2.25E-03	2.25E-03	2.25E-03	6.61E-03	6.61E-03	
	N2O (GWP=298)	2.16E-03	6.27E-04	6.27E-04	1.32E-03	1.32E-03	
	CO2e	1.18E+02	1.18E+02	1.18E+02	1.65E+02	1.65E+02	

40 CFR 98 - DEFAULT EMISSION FACTORS

Fuel Type	Table C-1 to Subpart C of Part 98	Table C-2 to Subpart C of Part 98		Weighted Sum
	Default HHV	Carbon Dioxide lb CO2/MMBtu	Methane lb CH4/MMBtu	Nitrous Oxide lb N2O/MMBtu
Fuel Oil No. 2 (Diesel)	138,000 Btu/gal	1.63E+02	6.61E-03	1.32E-03
Propane	91,000 Btu/gal	1.39E+02	6.61E-03	1.32E-03
Natural Gas	1,026 Btu/scf	1.17E+02	2.20E-03	2.20E-04

*Other/Trace HAPs include: CarbonTetrachloride, Chlorobenzene, Chloroform, Dichloropropene, 1,3-Dichloropropene, Ethylene Dibromide, Methylene Chloride, Phenol, Propylene Oxide, Styrene, 1,1,2,2-Tetrachloroethane, 1,1,2-Trichloroethane, and Vinyl Chloride (as per AP-42).

Global Warming Potential (100 Yr) (GWP)		
Table A-1 to Subpart A of Part 98		
CO2	CH4	N2O
1	25	298



Protocol for Equipment Leak Emission Estimates

TABLE 2-4. OIL AND GAS PRODUCTION OPERATIONS AVERAGE EMISSION FACTORS (kg/hr/source)

Equipment Type	Service ^a	Emission Factor (kg/hr/source) ^b
Valves	Gas	4.5E-03
	Heavy Oil	8.4E-06
	Light Oil	2.5E-03
	Water/Oil	9.8E-05
Pump seals	Gas	2.4E-03
	Heavy Oil	NA
	Light Oil	1.3E-02
	Water/Oil	2.4E-05
Others ^c	Gas	8.8E-03
	Heavy Oil	3.2E-05
	Light Oil	7.5E-03
	Water/Oil	1.4E-02
Connectors	Gas	2.0E-04
	Heavy Oil	7.5E-06
	Light Oil	2.1E-04
	Water/Oil	1.1E-04
Flanges	Gas	3.9E-04
	Heavy Oil	3.9E-07
	Light Oil	1.1E-04
	Water/Oil	2.9E-06
Open-ended lines	Gas	2.0E-03
	Heavy Oil	1.4E-04
	Light Oil	1.4E-03
	Water/Oil	2.5E-04

^aWater/Oil emission factors apply to water streams in oil service with a water content greater than 50%, from the point of origin to the point where the water content reaches 99%. For water streams with a water content greater than 99%, the emission rate is considered negligible.

^bThese factors are for total organic compound emission rates (including non-VOC's such as methane and ethane) and apply to light crude, heavy crude, gas plant, gas production, and off shore facilities. "NA" indicates that not enough data were available to develop the indicated emission factor.

^cThe "other" equipment type was derived from compressors, diaphragms, drains, dump arms, hatches, instruments, meters, pressure relief valves, polished rods, relief valves, and vents. This "other" equipment type should be applied for any equipment type other than connectors, flanges, open-ended lines, pumps, or valves.

Application Fee

Include a check payable to WVDEP – Division of Air Quality.

- As per WV Rule 22 (45CSR22) filed on May 6, 1991, a **Minimum fee of \$1,000** must be submitted for each 45CSR13 permit application filed with the WVDEP-DAQ.
 - **Additional Charges** may apply, depending on the nature of the application as outlined in Section 3.4.b. of Regulation 22, and shown below:
 - **NSPS Requirements:** **\$1,000** **JJJJ-Compressor Engines**
 - NESHAP Requirements: \$2,500 Not Applicable
 - New Major Source: \$10,000 Not Applicable
 - Major Modifications: \$5,000 Not Applicable
 - Total application fee is **\$2,000**
 [= \$1,000 Minimum Fee + \$1,000 Additional Charges]
-

**** End of Application for 45CSR13 New Source Review Permit Modification (NSR) ****