



July 7, 2016

Reference No. 082715

Ms. Beverly McKeone
Division of Air Quality
WV Department of Environmental Protection
601 57th Street, SE
Charleston, West Virginia 25304

Dear Ms. Beverly McKeone:

**Re: General Permit Registration G70-C Modification Application
Vogt Well Pad
Antero Resources Corporation**

GHD Services Inc. (GHD) would like to submit this General Permit Modification application that we prepared on behalf of Antero Resources Corporation for an oil and gas facility identified as Vogt Well Pad.

A General Permit Registration Modification is requested due to the following planned operational changes:

1. Increase in condensate production.
2. Addition of 2 Cimarron enclosed combustors.
3. Addition of 10 line heaters.

Please refer to Table 14 in Attachment S - Emissions Calculations for the summary of changes in emissions of regulated air pollutants that will result from the above operational changes.

Enclosed are the following documents:

- Original copy of the G70-C General Permit Modification Application.
- Two CD copies of the G70-C General Permit Modification Application.
- The application fee with check no. 449973 in the amount of \$1,500.00.

Please let us know if you have any questions or require additional information.

Sincerely,

GHD Services Inc.

A handwritten signature in black ink, appearing to read 'Manuel Bautista', written in a cursive style.

Manuel Bautista

MB/ma/253

Encl.

cc: Barry Schatz, Antero Resources Corporation
Elizabeth McLaughlin, Antero Resources Corporation

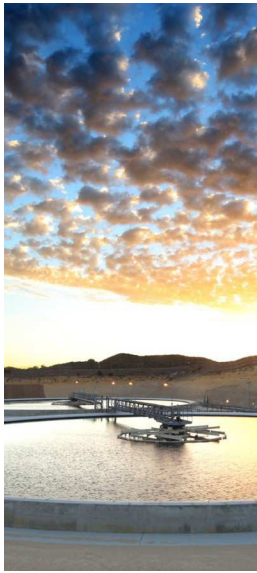

General Permit G70-C Modification Application

Increase in condensate production, and addition of ten line heaters and two Cimarron enclosed combustors.

Vogt Well Pad

Antero Resources Corporation

GHD Services Inc.
6320 Rothway Suite 100 Houston Texas 77040
082715 | Report No 253 | July 2016

Table of Contents

G70-C General Permit Modification

Attachment A	Single Source Determination Form
Attachment B	Siting Criteria Waiver – Not Applicable
Attachment C	Current Business Certificate
Attachment D	Process Flow Diagram
Attachment E	Process Description
Attachment F	Plot Plan
Attachment G	Area Map
Attachment H	G70-C Section Applicability Form
Attachment I	Emission Units/ERD Table
Attachment J	Fugitive Emissions Summary Sheet
Attachment K	Gas Well Affected Facility Data Sheet
Attachment L	Storage Vessel(s) Data Sheet
Attachment M	Natural Gas Fired Fuel Burning Unit(s) Data Sheet
Attachment N	Internal Combustion Engine Data Sheet
Attachment O	Tanker Truck Loading Data Sheet
Attachment P	Glycol Dehydration Unit Sheet(s) – Not Applicable
Attachment Q	Pneumatic Controllers Data Sheet – Not Applicable
Attachment R	Air Pollution Control Device/ Emissions Reduction Device(s) Sheet(s)
Attachment S	Emission Calculations
Attachment T	Facility-wide Emissions Summary Sheet(s)
Attachment U	Class I Legal Advertisement



west virginia department of environmental protection

Division of Air Quality
601 57th Street SE
Charleston, WV 25 4
Phone (304) 926-0475
Fax (304) 926-0479
www.dep.wv.gov

G70-C GENERAL PERMIT REGISTRATION APPLICATION

PREVENTION AND CONTROL OF AIR POLLUTION IN REGARD TO THE CONSTRUCTION, MODIFICATION, RELOCATION, ADMINISTRATIVE UPDATE AND OPERATION OF NATURAL GAS PRODUCTION FACILITIES LOCATED AT THE WELL SITE

- CONSTRUCTION
- MODIFICATION
- RELOCATION
- CLASS I ADMINISTRATIVE UPDATE
- CLASS II ADMINISTRATIVE UPDATE

SECTION 1. GENERAL INFORMATION

Name of Applicant (as registered with the WV Secretary of State's Office): Antero Resources Corporation

Federal Employer ID No. (FEIN): 80-0162034

Applicant's Mailing Address: 1615 Wynkoop Street

City: Denver

State: CO

ZIP Code: 80202

Facility Name: Vogt Well Pad

Operating Site Physical Address: 130 Coopers Ridge Rd.

City: Greenwood

Zip Code: 26415

County: Doddridge

Latitude & Longitude Coordinates (NAD83, Decimal Degrees to 5 digits):

Latitude: 39.27757

Longitude: -80.86212

SIC Code: 1311

DAQ Facility ID No. (For existing facilities)

NAICS Code: 211111

017-00073

CERTIFICATION OF INFORMATION

This G70-C General Permit Registration Application shall be signed below by a Responsible Official. A Responsible Official is a President, Vice President, Secretary, Treasurer, General Partner, General Manager, a member of the Board of Directors, or Owner, depending on business structure. A business may certify an Authorized Representative who shall have authority to bind the Corporation, Partnership, Limited Liability Company, Association, Joint Venture or Sole Proprietorship. Required records of daily throughput, hours of operation and maintenance, general correspondence, compliance certifications and all required notifications must be signed by a Responsible Official or an Authorized Representative. If a business wishes to certify an Authorized Representative, the official agreement below shall be checked off and the appropriate names and signatures entered. **Any administratively incomplete or improperly signed or unsigned G70-C Registration Application will be returned to the applicant. Furthermore, if the G70-C forms are not utilized, the application will be returned to the applicant. No substitution of forms is allowed.**

I hereby certify that Barry Schatz is an Authorized Representative and in that capacity shall represent the interest of the business (e.g., Corporation, Partnership, Limited Liability Company, Association Joint Venture or Sole Proprietorship) and may obligate and legally bind the business. If the business changes its Authorized Representative, a Responsible Official shall notify the Director of the Division of Air Quality immediately.

I hereby certify that all information contained in this G70-C General Permit Registration Application and any supporting documents appended hereto is, to the best of my knowledge, true, accurate and complete, and that all reasonable efforts have been made to provide the most comprehensive information possible.

Responsible Official Signature: _____

Name and Title:

Phone:

Fax:

Email:

Date:

If applicable:

Authorized Representative Signature: Barry Schatz
Name and Title: Barry Schatz/ Senior Environmental & Regulatory Manager Phone: 303-357-7276 Fax: 303-357-7315

Email: bschatz@anteroresources.com Date: 7/7/2016

If applicable:

Environmental Contact

Name and Title:

Phone:

Fax:

Email:

Date:

OPERATING SITE INFORMATION	
Briefly describe the proposed new operation and/or any change(s) to the facility: Increase in condensate production and the addition of 10 line heaters and 2 Cimarron enclosed combustors.	
Directions to the facility: From Clarksburg, head west on US-50 for 30 mi. Turn right on Stone Valley Road and drive 0.1 mi. Take left on County Route 36/Duckworth Road. Continue on Duckworth Road for 1.6 mi and then turn right. The destination will be on the right after the Duckworth Cemetery.	
ATTACHMENTS AND SUPPORTING DOCUMENTS	
I have enclosed the following required documents:	
Check payable to WVDEP – Division of Air Quality with the appropriate application fee (per 45CSR13 and 45CSR22).	
<input checked="" type="checkbox"/> Check attached to front of application. <input type="checkbox"/> I wish to pay by electronic transfer. Contact for payment (incl. name and email address): <input type="checkbox"/> I wish to pay by credit card. Contact for payment (incl. name and email address):	
<input checked="" type="checkbox"/> \$500 (Construction, Modification, and Relocation) <input type="checkbox"/> \$300 (Class II Administrative Update) <input checked="" type="checkbox"/> \$1,000 NSPS fee for 40 CFR60, Subpart IIII, JJJJ and/or OOOO ¹ <input type="checkbox"/> \$2,500 NESHAP fee for 40 CFR63, Subpart ZZZZ and/or HH ²	
¹ Only one NSPS fee will apply. ² Only one NESHAP fee will apply. The Subpart ZZZZ NESHAP fee will be waived for new engines that satisfy requirements by complying with NSPS, Subparts IIII and/or JJJJ. <i>NSPS and NESHAP fees apply to new construction or if the source is being modified.</i>	
<input checked="" type="checkbox"/> Responsible Official or Authorized Representative Signature (if applicable)	
<input checked="" type="checkbox"/> Single Source Determination Form (must be completed in its entirety) – Attachment A	
<input type="checkbox"/> Siting Criteria Waiver (if applicable) – Attachment B	<input checked="" type="checkbox"/> Current Business Certificate – Attachment C
<input checked="" type="checkbox"/> Process Flow Diagram – Attachment D	<input checked="" type="checkbox"/> Process Description – Attachment E
<input checked="" type="checkbox"/> Plot Plan – Attachment F	<input checked="" type="checkbox"/> Area Map – Attachment G
<input checked="" type="checkbox"/> G70-C Section Applicability Form – Attachment H	<input checked="" type="checkbox"/> Emission Units/ERD Table – Attachment I
<input checked="" type="checkbox"/> Fugitive Emissions Summary Sheet – Attachment J	
<input checked="" type="checkbox"/> Gas Well Affected Facility Data Sheet (if applicable) – Attachment K	
<input checked="" type="checkbox"/> Storage Vessel(s) Data Sheet (include gas sample data, USEPA Tanks, simulation software (e.g. ProMax, E&P Tanks, HYSYS, etc.), etc. where applicable) – Attachment L	
<input checked="" type="checkbox"/> Natural Gas Fired Fuel Burning Unit(s) Data Sheet (GPU's, Heater Treaters, In-Line Heaters if applicable) – Attachment M	
<input checked="" type="checkbox"/> Internal Combustion Engine Data Sheet(s) (include manufacturer performance data sheet(s) if applicable) – Attachment N	
<input checked="" type="checkbox"/> Tanker Truck Loading Data Sheet (if applicable) – Attachment O	
<input type="checkbox"/> Glycol Dehydration Unit Data Sheet(s) (include wet gas analysis, GRI- GLYCalc™ input and output reports and information on reboiler if applicable) – Attachment P	
<input type="checkbox"/> Pneumatic Controllers Data Sheet – Attachment Q	
<input checked="" type="checkbox"/> Air Pollution Control Device/Emission Reduction Device(s) Sheet(s) (include manufacturer performance data sheet(s) if applicable) – Attachment R	
<input checked="" type="checkbox"/> Emission Calculations (please be specific and include all calculation methodologies used) – Attachment S	
<input checked="" type="checkbox"/> Facility-wide Emission Summary Sheet(s) – Attachment T	
<input checked="" type="checkbox"/> Class I Legal Advertisement – Attachment U	
<input checked="" type="checkbox"/> One (1) paper copy and two (2) copies of CD or DVD with pdf copy of application and attachments	

GHD SERVICES INC.

PLEASE DETACH AND RETAIN FOR YOUR RECORDS

INVOICE NUMBER	DATE	VOUCHER NO.	AMOUNT
----------------	------	-------------	--------

Account Number:
CR61716

6/17/2016

40WVDEPAQ

401010375

449973

1,500.00

TOTAL: 1,500.00

THIS DOCUMENT IS PROTECTED BY A MICRO-PRINT SIGNATURE LINE, FLUORESCENT PAPER FIBERS, A WATERMARKED BACKER, AND IS REACTIVE TO CHEMICAL ALTERATION

GHD SERVICES INC.
2055 NIAGARA FALLS BLVD, SUITE 3
NIAGARA FALLS, NY 14304

M&T BANK
MANUFACTURERS AND TRADERS TRUST COMPANY
Commercial Banking
Main Office, Ithaca, NY 14850
60-7063-2213

6/17/2016

NO. 449973

PAY *****1,500 DOLLARS AND *****00 CENTS \$ *****1,500.00

TO THE
ORDER
OF

**West Virginia Dept of Environmental
Protection - Division Air Quality
601 57th Street SE
Charleston, WV 25304 US**

[Handwritten Signature]
GHD SERVICES INC.

AUTHORIZED SIGNATURES

WARNING: THIS DOCUMENT IS VOID IF ACCOUNT NUMBER DOES NOT APPEAR ON THE REVERSE SIDE IN RED

⑈ 449973 ⑈ ⑆ 221370632⑆ ⑆ 1000000 ⑆ 18910 ⑈

**Attachment R
AUTHORITY OF CORPORATION
OR OTHER BUSINESS ENTITY (DOMESTIC OR FOREIGN)**

TO: The West Virginia Department of Environmental Protection,
Division of Air Quality

DATE: January 23, 2015

ATTN.: Director

Corporation's / other business entity's Federal Employer I.D. Number 80-0162034

The undersigned hereby files with the West Virginia Department of Environmental Protection, Division of Air Quality, a permit application and hereby certifies that the said name is a trade name which is used in the conduct of an incorporated business or other business entity.

Further, the corporation or the business entity certifies as follows:

(1) Barry Schatz (is/are) the authorized representative(s) and in that capacity may represent the interest of the corporation or the business entity and may obligate and legally bind the corporation or the business entity.

(2) The corporation or the business entity is authorized to do business in the State of West Virginia.

(3) If the corporation or the business entity changes its authorized representative(s), the corporation or the business entity shall notify the Director of the West Virginia Department of Environmental Protection, Division of Air Quality, immediately upon such change.



President or Other Authorized Officer
(Vice President, Secretary, Treasurer or other
official in charge of a principal business function of
the corporation or the business entity)

(If not the President, then the corporation or the business entity must submit certified minutes or bylaws stating legal authority of other authorized officer to bind the corporation or the business entity).

Secretary

Name of Corporation or business entity

Attachment A

Single Source Determination Form

ATTACHMENT A - SINGLE SOURCE DETERMINATION FORM

Classifying multiple facilities as one “stationary source” under 45CSR13, 45CSR14, and 45CSR19 is based on the definition of Building, structure, facility, or installation as given in §45-14-2.13 and §45-19-2.12. The definition states:

“Building, Structure, Facility, or Installation” means all of the pollutant-emitting activities which belong to the same industrial grouping, are located on one or more contiguous or adjacent properties, and are under the control of the same person (or persons under common control). Pollutant-emitting activities are a part of the same industrial grouping if they belong to the same “Major Group” (i.e., which have the same two (2)-digit code) as described in the Standard Industrial Classification Manual, 1987 (United States Government Printing Office stock number GPO 1987 0-185-718:QL 3).

Is there a facility owned by or associated with the natural gas industry located within one (1) mile of the proposed facility? Yes No

If Yes, please complete the questionnaire on the following page (Attachment A).

Please provide a source aggregation analysis for the proposed facility below:

The Vogt Well Pad calculation of potential to emit included all the emissions sources that belong to the same industrial grouping, are located on contiguous or adjacent properties, and are under the control of the same person. The nearest emission source that belongs to the same industrial grouping and under the control of the same person but not located on contiguous or adjacent property is the Dotson-Holland Well Pad. This operates independently and is approximately 0.60 mile southwest of the facility. There is one other nearby source, McGill Well Pad that belongs to the same industrial grouping and is under the same control but not located on contiguous or adjacent property. This well pad is located approximately 0.70 mile southeast of Vogt Well Pad and operates completely independent.

ATTACHMENT A - SINGLE SOURCE DETERMINATION FORM

Answer each question with a detailed explanation to determine contiguous or adjacent properties which are under a common control and any support facilities. This section must be completed in its entirety.

Provide a map of contiguous or adjacent facilities (production facilities, compressor stations, dehydration facilities, etc.) which are under common control and those facilities that are not under common control but are support facilities. Please indicate the SIC code, permit number (if applicable), and the distance between facilities in question on the map.

Are the facilities owned by the same parent company or a subsidiary of the parent company? Provide the owners identity and the percentage of ownership of each facility. Antero Resources has 100% ownership of each facility.	Yes <input checked="" type="checkbox"/>	No <input type="checkbox"/>
Does an entity such as a corporation have decision making authority over the operation of a second entity through a contractual agreement or voting interest? Please explain.	Yes <input type="checkbox"/>	No <input checked="" type="checkbox"/>
Is there a contract for service relationship between the two (2) companies or, a support/dependency relationship that exists between the two (2) companies? Please explain.	Yes <input type="checkbox"/>	No <input checked="" type="checkbox"/>
Do the facilities share common workforces, plant managers, security forces, corporate executive officers or board executives?	Yes <input checked="" type="checkbox"/>	No <input type="checkbox"/>
Will managers or other workers frequently shuttle back and forth to be involved actively at both facilities?	Yes <input type="checkbox"/>	No <input checked="" type="checkbox"/>
Do the facilities share common payroll activities, employee benefits, health plans, retirement funds, insurance coverage, or other administrative functions? Please explain.	Yes <input type="checkbox"/>	No <input checked="" type="checkbox"/>
Does one (1) facility operation support the operation of the other facility?	Yes <input type="checkbox"/>	No <input checked="" type="checkbox"/>
Is one (1) facility dependent on the other? If one (1) facility shuts down, what are the limitations on the other to pursue outside business? Please explain. No, these facilities operate completely independently.	Yes <input type="checkbox"/>	No <input checked="" type="checkbox"/>
Are there any financial arrangements between the two (2) entities?	Yes <input type="checkbox"/>	No <input checked="" type="checkbox"/>
Are there any legal or lease agreements between the two (2) facilities?	Yes <input type="checkbox"/>	No <input checked="" type="checkbox"/>
Do the facilities share products, byproducts, equipment, or other manufacturing or air pollution control device equipment? Please explain. No, these facilities operate completely independently.	Yes <input type="checkbox"/>	No <input checked="" type="checkbox"/>
Do all the pollutant-emitting activities at the facilities belong to the same SIC Code? Please provide the SIC Codes. 1311	Yes <input checked="" type="checkbox"/>	No <input type="checkbox"/>
Was the location of the new facility chosen primarily because of its proximity to the existing facility to integrate the operation of the two (2) facilities? Please explain. No, these facilities operate completely independently.	Yes <input type="checkbox"/>	No <input checked="" type="checkbox"/>
Will materials be routinely transferred between the two (2) facilities? Please explain the amount of transfer and how often the transfers take place and what percentages go to the various entities.	Yes <input type="checkbox"/>	No <input checked="" type="checkbox"/>
Does the facility influence production levels or compliance with environmental regulations at other facilities? Who accepts the responsibility for compliance with air quality requirements? Please explain. No, these facilities operate completely independently.	Yes <input type="checkbox"/>	No <input checked="" type="checkbox"/>

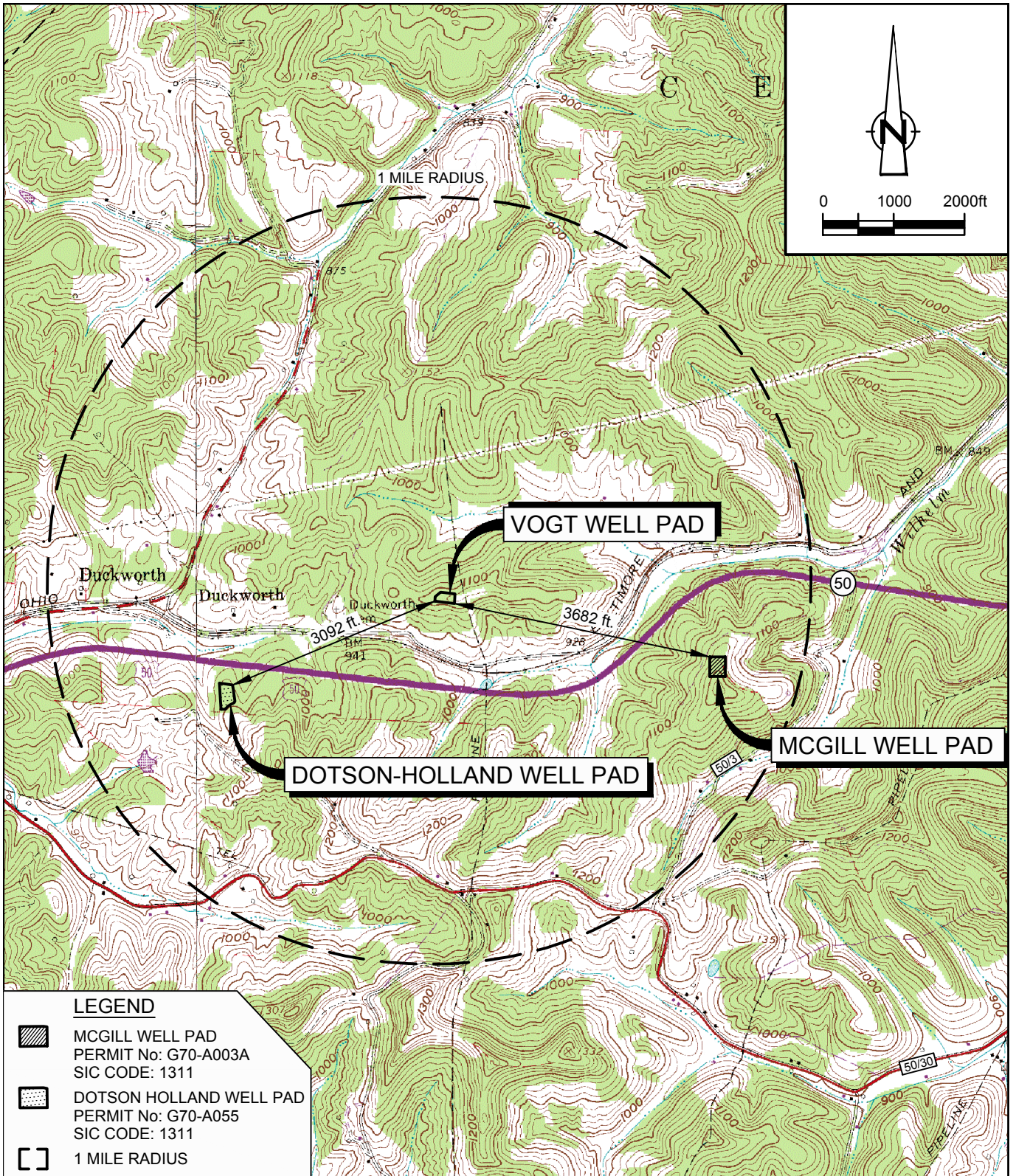

SOURCE: USGS QUADRANGLE MAP;
WEST UNION, WEST VIRGINIA
PENNSBORO, WEST VIRGINIA

SITE COORDINATES: LAT: 39.277572, LONG: -80.862125



Attachmnet A

SINGLE SOURCE DETERMINATION
VOGT WELL PAD
ANTERO RESOURCES
Doddridge County, West Virginia

Attachment B

Siting Criteria Waiver

Attachment B

Siting Waiver

Vogt Well Pad

**Antero Resources Corporation
Doddridge County, West Virginia**

A Siting Waiver form is not required because there are no occupied dwelling structures within 300 feet of Vogt Well Pad.

Attachment C

Current Business Certificate

State of West Virginia

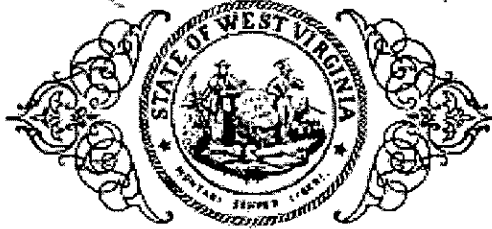

Certificate

I, Natalie E. Tennant, Secretary of State of the State of West Virginia, hereby certify that

ANTERO RESOURCES CORPORATION

a corporation formed under the laws of Delaware, which is authorized to transact business in West Virginia by a Certificate of Authority has filed in my office as required by the provisions of the West Virginia Code, a copy of an amendment to its Articles of Incorporation authenticated by the proper office of the state or country of its incorporation and was found to conform to law.

Therefore, I issue this

CERTIFICATE OF AMENDMENT TO CERTIFICATE OF AUTHORITY



*Given under my hand and the
Great Seal of the State of
West Virginia on this day of
June 10, 2013*

Natalie E. Tennant

Secretary of State

FILED

JUN 10 2013

Natalie E. Tennant
Secretary of State
1900 Kanawha Blvd E
Bldg 1, Suite 157-K
Charleston, WV 25305



Penney Barker, Manager
IN THE OFFICE OF Corporations Division
SECRETARY OF STATE Tel: (304)558-8000
Fax: (304)558-8381

Website: www.wvsos.com
E-mail: business@wvsos.com

Office Hours: Monday – Friday
8:30 a.m. – 5:00 p.m. ET

**APPLICATION FOR
AMENDED CERTIFICATE
OF AUTHORITY**

FILE ONE ORIGINAL
(Two if you want a filed
stamped copy returned to you)
FEE: \$25.00

**** In accordance with the provisions of the West Virginia Code, the undersigned corporation hereby ****
applies for an Amended Certificate of Authority and submits the following statement:

- Name under which the corporation was authorized to transact business in WV: Antero Resources Appalachian Corporation
- Date Certificate of Authority was issued in West Virginia: 6/25/2008
- Corporate name has been changed to: Antero Resources Corporation
(Attach one **Certified Copy of Name Change** as filed in home State of Incorporation.)
- Name the corporation elects to use in WV: Antero Resources Corporation
(due to home state name not being available)
- Other amendments: _____
(attach additional pages if necessary)

6. Name and phone number of contact person. (This is optional, however, if there is a problem with the filing, listing a contact person and phone number may avoid having to return or reject the document.)

Alvyn A. Schopp (303) 367-7310
Contact Name Phone Number

7. Signature information (See below ***Important Legal Notice Regarding Signature***):

Print Name of Signer: Alvyn A. Schopp Title/Capacity: Authorized Person

Signature: Date: June 10, 2013

***Important Legal Notice Regarding Signature:** Per West Virginia Code §31D-1-129. Penalty for signing false document. Any person who signs a document he or she knows is false in any material respect and knows that the document is to be delivered to the secretary of state for filing is guilty of a misdemeanor and, upon conviction thereof, shall be fined not more than one thousand dollars or confined in the county or regional jail not more than one year, or both.

Delaware

PAGE 1

The First State

I, JEFFREY W. BULLOCK, SECRETARY OF STATE OF THE STATE OF DELAWARE, DO HEREBY CERTIFY THE ATTACHED IS A TRUE AND CORRECT COPY OF THE CERTIFICATE OF AMENDMENT OF "ANTERO RESOURCES APPALACHIAN CORPORATION", CHANGING ITS NAME FROM "ANTERO RESOURCES APPALACHIAN CORPORATION" TO "ANTERO RESOURCES CORPORATION", FILED IN THIS OFFICE ON THE TENTH DAY OF JUNE, A.D. 2013, AT 9:37 O'CLOCK A.M.

A FILED COPY OF THIS CERTIFICATE HAS BEEN FORWARDED TO THE NEW CASTLE COUNTY RECORDER OF DEEDS.

4520810 8100

130754186



You may verify this certificate online
at corp.delaware.gov/authver.shtml

Jeffrey W. Bullock, Secretary of State
AUTHENTICATION: 0496546

DATE: 06-10-13

AMENDMENT TO THE
AMENDED AND RESTATED
CERTIFICATE OF INCORPORATION
OF
ANTERO RESOURCES APPALACHIAN CORPORATION

Antero Resources Appalachian Corporation (the "Corporation"), a corporation organized and existing under the laws of the State of Delaware, hereby certifies as follows:

1. The original Certificate of Incorporation of the Corporation was filed under the name Antero Resources Barnett Corporation with the filing of the original Certificate of Incorporation of the Corporation with the Secretary of State of the State of Delaware on March 18, 2008.

2. This Amendment to the Amended and Restated Certificate of Incorporation has been duly adopted and approved in accordance with Sections 242 of the General Corporation Law of the State of Delaware.

3. Article FIRST of the Amended and Restated Certificate of Incorporation is hereby amended to read in its entirety as follows:

FIRST. The name of the Corporation is Antero Resources Corporation.

IN WITNESS WHEREOF, the Corporation has caused this Certificate of Amendment to be executed by its duly authorized officer on the 10th day of June, 2013.

ANTERO RESOURCES APPALACHIAN CORPORATION

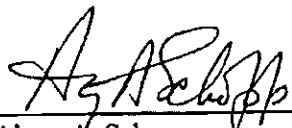
By: 
Name: Alwyn A. Schopp
Title: Vice President of Accounting &
Administration / Treasurer

Attachment D

Process Flow Diagram

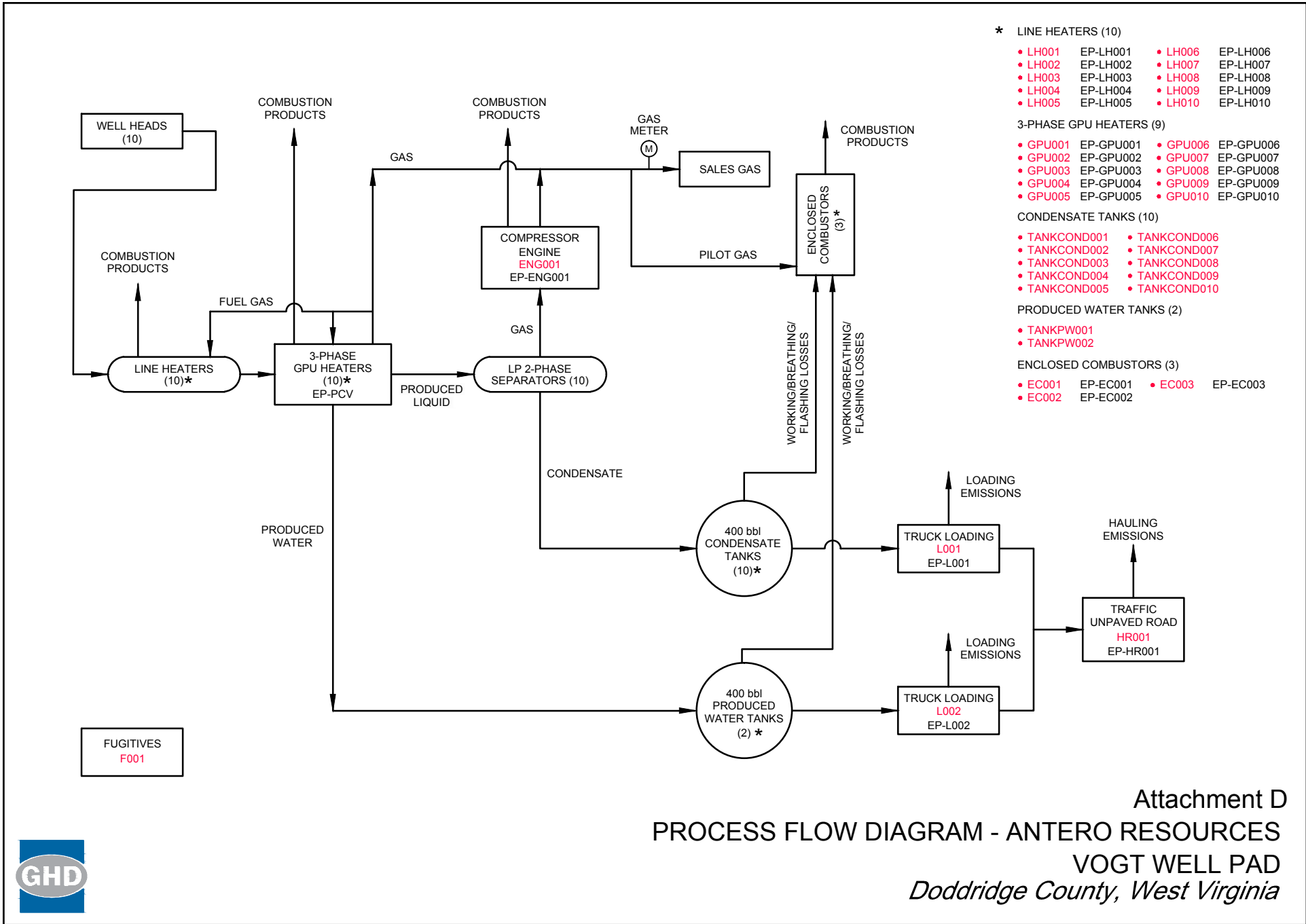

Attachment D
PROCESS FLOW DIAGRAM - ANTERO RESOURCES
VOGT WELL PAD
Doddridge County, West Virginia



Attachment E

Process Description

Attachment E

Process Description

Vogt Well Pad

Antero Resources Corporation

Doddridge County, West Virginia

A mixture of condensate, water, and entrained gas from the condensate and gas wells enters the facility through a series of line heaters (LH001-010) and gas production units (GPU001-GPU010) which are 3-phase separators where the gas, condensate, and produced water are separated. The line heaters and GPUs are fueled by a slip stream of the separated gas.

The gas from the three phase separators is metered and sent to the sales gas pipeline. The water flow to the produced water storage tanks (TANKPW001-002). The condensate is then sent to two phase low pressure separators where gas is further separated. The gas is routed to the gas fueled compressor engine (ENG001), compressed, metered and sent to the sales gas line. The condensate from the two phase separators flows to the condensate storage tanks (TANKSCOND001-010). The line heaters are only used during the first several months from start of production and will be removed once production has normalized.

The facility has ten (10) tanks (TANKCOND001-010) on site to store condensate and two (2) tanks (TANKPW001-002) to store produced water prior to removal from the site. The flashing, working and breathing losses from the tanks are routed to three enclosed combustors (EC001-003) to control the emissions. The enclosed combustor(s) that will be used to control emissions are designed to achieve a VOC destruction efficiency of 98 percent.

Condensate and produced water are transported off site on an as needed basis via tanker truck. Truck loading connections are in place to pump condensate (L001) and produced water (L002) from the storage tanks into tanker trucks. Emissions from the loading operations are vented to the atmosphere.

Emissions from the facility's emission sources were calculated using the site specific extended analysis of the condensate and gas from Seaborn Unit 1H well, one of the wells in the Vogt Well Pad.

Attachment F

Plot Plan

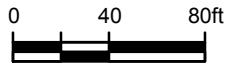

ENCLOSED
COMBUSTORS

EC001 (EP-EC001)
EC002 (EP-EC002)
EC003 (EP-EC003)

ACCESS
ROAD

VOGT UNIT 1H *
McGILL UNIT 2H *
McGILL UNIT 1H *
DUCKBILL UNIT 1H *
DUCKBILL UNIT 2H *
MAPLE UNIT 1H *
MARKS UNIT 1H *
VIOLET UNIT 1H ○
SEABORN UNIT 1H ○
SEABORN UNIT 2H ○

GPU001 (EP-GPU001)
GPU002 (EP-GPU002)
GPU003 (EP-GPU003)

PRODUCTION
EQUIPMENT
(EP-PCV)

GPU004 (EP-GPU004)
GPU005 (EP-GPU005)
GPU006 (EP-GPU006)
GPU007 (EP-GPU007)
GPU008 (EP-GPU008)
GPU009 (EP-GPU009)
GPU010 (EP-GPU010)

FACILITY
FUGITIVES
(F001)

COMPRESSOR
ENGINE
ENG001
(EP-ENG001)

HAULING ROUTE
(EP-HR001)
HR001

(EP-L001)
(EP-L002)
L001
L002

TANKPW001	TANKCOND005
TANKPW002	TANKCOND006
TANKCOND001	TANKCOND007
TANKCOND002	TANKCOND008
TANKCOND003	TANKCOND009
TANKCOND004	TANKCOND010

LEGEND

- EXISTING WELL LOCATION
- * PROPOSED WELL LOCATION



Attachment F
PLOT PLAN
VOGT WELL PAD
Doddrige County, West Virginia

Attachment G

Area Map

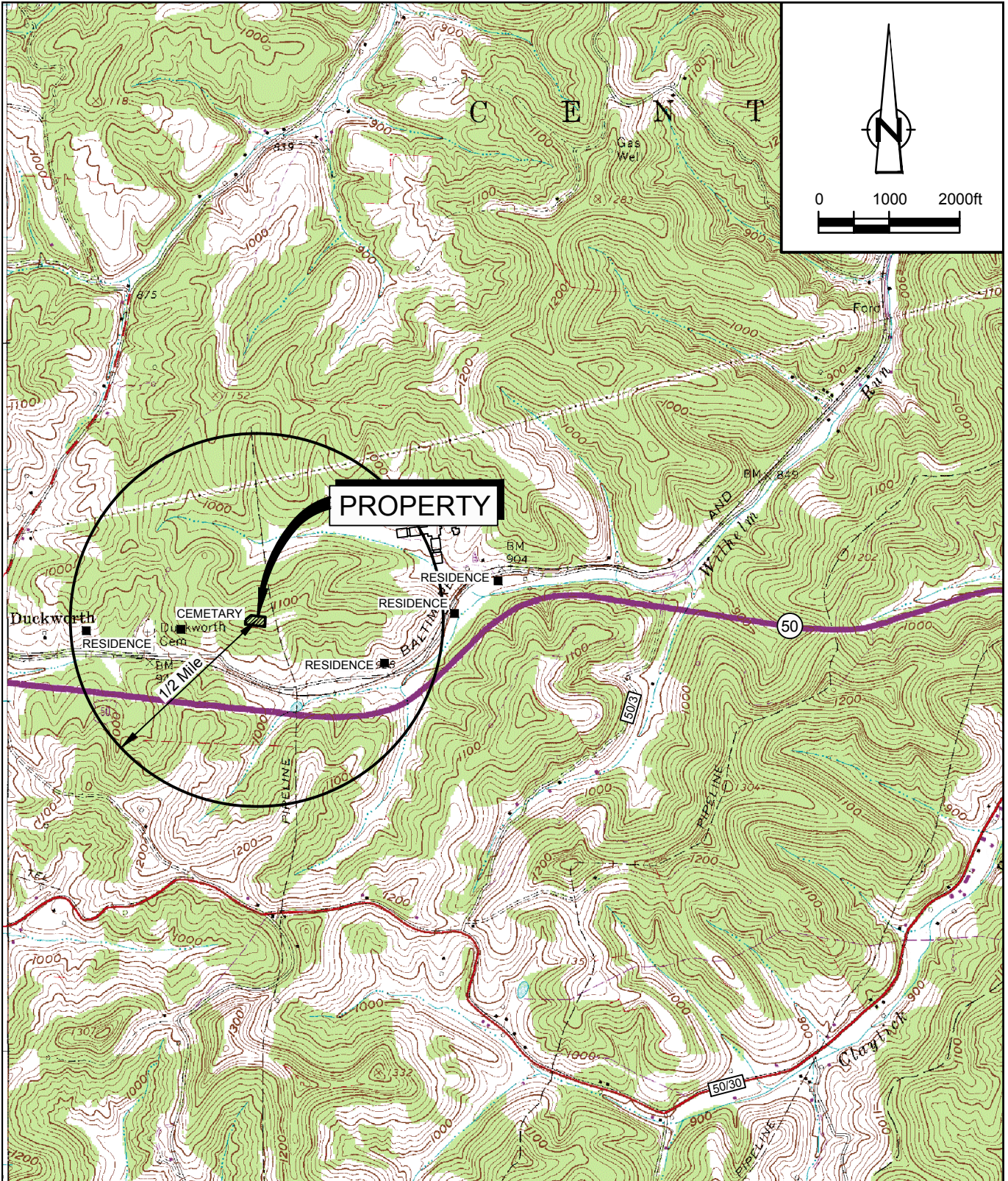

SOURCE: USGS QUADRANGLE MAP;
WEST UNION, WEST VIRGINIA

SITE COORDINATES: LAT: 39.277572, LONG: -80.862125
SITE ELEVATION: 1120 ft AMSL



Attachment G
AREA MAP
VOGT WELL PAD
ANTERO RESOURCES
Doddridge County, West Virginia

Attachment H

G70-C Section Applicability Form

ATTACHMENT H – G70-C SECTION APPLICABILITY FORM

**General Permit G70-C Registration
Section Applicability Form**

General Permit G70-C was developed to allow qualified applicants to seek registration for a variety of sources. These sources include gas well affected facilities, storage vessels, gas production units, in-line heaters, heater treaters, glycol dehydration units and associated reboilers, pneumatic controllers, centrifugal compressors, reciprocating compressors, reciprocating internal combustion engines (RICEs), tank truck loading, fugitive emissions, completion combustion devices, flares, enclosed combustion devices, and vapor recovery systems. All registered facilities will be subject to Sections 1.0, 2.0, 3.0, and 4.0.

General Permit G70-C allows the registrant to choose which sections of the permit they are seeking registration under. Therefore, please mark which additional sections that you are applying for registration under. If the applicant is seeking registration under multiple sections, please select all that apply. Please keep in mind, that if this registration is approved, the issued registration will state which sections will apply to your affected facility.

GENERAL PERMIT G70-C APPLICABLE SECTIONS	
<input checked="" type="checkbox"/> Section 5.0	Gas Well Affected Facility (NSPS, Subpart OOOO)
<input checked="" type="checkbox"/> Section 6.0	Storage Vessels Containing Condensate and/or Produced Water ¹
<input type="checkbox"/> Section 7.0	Storage Vessel Affected Facility (NSPS, Subpart OOOO)
<input checked="" type="checkbox"/> Section 8.0	Control Devices and Emission Reduction Devices not subject to NSPS Subpart OOOO and/or NESHAP Subpart HH
<input checked="" type="checkbox"/> Section 9.0	Small Heaters and Reboilers not subject to 40CFR60 Subpart Dc
<input type="checkbox"/> Section 10.0	Pneumatic Controllers Affected Facility (NSPS, Subpart OOOO)
<input type="checkbox"/> Section 11.0	Centrifugal Compressor Affected Facility (NSPS, Subpart OOOO) ²
<input type="checkbox"/> Section 12.0	Reciprocating Compressor Affected Facility (NSPS, Subpart OOOO) ²
<input checked="" type="checkbox"/> Section 13.0	Reciprocating Internal Combustion Engines, Generator Engines, Microturbines
<input checked="" type="checkbox"/> Section 14.0	Tanker Truck Loading ³
<input type="checkbox"/> Section 15.0	Glycol Dehydration Units ⁴

- 1 Applicants that are subject to Section 6 may also be subject to Section 7 if the applicant is subject to the NSPS, Subpart OOOO control requirements or the applicable control device requirements of Section 8.
- 2 Applicants that are subject to Section 11 and 12 may also be subject to the applicable RICE requirements of Section 13.
- 3 Applicants that are subject to Section 14 may also be subject to control device and emission reduction device requirements of Section 8.
- 4 Applicants that are subject to Section 15 may also be subject to the requirements of Section 9 (reboilers). Applicants that are subject to Section 15 may also be subject to control device and emission reduction device requirements of Section 8.

Attachment I Emission Units/ ERD Table

ATTACHMENT I – EMISSION UNITS / EMISSION REDUCTION DEVICES (ERD) TABLE

Include ALL emission units and air pollution control devices /ERDs that will be part of this permit application review. This information is required for all sources regardless of whether it is a construction, modification, or administrative update.

Emission Unit ID ¹	Emission Point ID ²	Emission Unit Description	Year Installed/ Modified	Manufac. Date ³	Design Capacity	Type ⁴ and Date of Change	Control Device(s) ⁵	ERD (s) ⁶
GPU001, GPU002, GPU003, GPU004, GPU005, GPU006, GPU007, GPU008, GPU009, GPU010	EP-GPU001, EP-GPU002, EP-GPU003, EP-GPU004, EP-GPU005, EP-GPU006, EP-GPU007, EP-GPU008, EP-GPU009, EP-GPU010	Gas Production Unit Heater	GPU 001-003 : 2013 GPU 004-010 :2014		1.5 MMBtu/hr	Existing	N/A	
LH001, LH002, LH003, LH004, LH005, LH006, LH007, LH008, LH009, LH010	EP-LH001, EP-LH002, EP-LH003, EP-LH004, EP-LH005, EP-LH006, EP-LH007, EP-LH008, EP-LH009, EP-LH010	Line Heater	2016		2.0 MMBtu/hr	New	N/A	
F001	F001	Fugitives	2013		N/A	Existing	N/A	
TANKCOND001-010	EP-EC001, EP-EC002, EP-EC003	Condensate Tank F/W/B	TANKCOND001-004:2013, TANKCOND005-007:2014, TANKCOND008-010:2015		400 bbl each	Existing	EC001, EC002, EC003	
TANKPW001-002	EP-EC001, EP-EC002, EP-EC003	PW Tank F/W/B	2013		400 bbl each	Existing	EC001, EC002, EC003	
L001	EP-L001	Loading (Condensate)	2013		200 bbl capacity (each)	Existing	N/A	
L002	EP-L002	Loading (Produced Water)	2013		200 bbl capacity (each)	Existing	N/A	
HR001	EP-HR001	Haul Truck	2013		40 ton capacity	Existing	N/A	
EC001	EP-EC001	Enclosed Combustor	2013		90 scf/min	Existing	N/A	
EC002	EP-EC002	Enclosed Combustor	2016		90 scf/min	New	N/A	
EC003	EP-EC003	Enclosed Combustor	2016		90 scf/min	New	N/A	
PCV	EP-PCV	Pneumatic CV	2013		6.6 scf/day/PCV	Existing	N/A	
ENG001	EP-ENG001	Compressor Engine	2014	2013	24 HP	Existing	Non-Selective Catalytic Reduction	

¹ For Emission Units (or Sources) use the following numbering system: 1S, 2S, 3S, ... or other appropriate designation.

² For Emission Points use the following numbering system: 1E, 2E, 3E, ... or other appropriate designation.

³ When required by rule.

⁴ New, modification, removal, existing.

⁵ For Control Devices use the following numbering system: 1C, 2C, 3C, ... or other appropriate designation.

⁶ For ERDs use the following numbering system: 1D, 2D, 3D, ... or other appropriate designation.

Attachment J

Fugitive Emissions Summary Sheet

ATTACHMENT J – FUGITIVE EMISSIONS SUMMARY SHEET

Sources of fugitive emissions may include loading operations, equipment leaks, blowdown emissions , etc.

Use extra pages for each associated source or equipment if necessary.

Source/Equipment:

Leak Detection Method Used		<input type="checkbox"/> Audible, visual, and	<input checked="" type="checkbox"/> Infrared (FLIR) cameras	<input type="checkbox"/> Other (please describe)	<input type="checkbox"/> None required			
Component Type	Closed Vent System	Count	Monitor Frequency	Source of Leak Factors (EPA, other (specify))	Stream type (gas, liquid, etc.)	Estimated Emissions (tpy)		
						VOC	HAP	GHG (CO2e)
Valves	<input type="checkbox"/> Yes <input checked="" type="checkbox"/> No	500	Quarterly monitoring	EPA	gas	3.59	0.23	338.72
Valves	<input type="checkbox"/> Yes <input checked="" type="checkbox"/> No	520	Quarterly monitoring	EPA	liquid	12.01	1.35	4.44
Connections (Not sampling)	<input type="checkbox"/> Yes <input checked="" type="checkbox"/> No	590	Quarterly monitoring	EPA	gas	0.19	1.21E-02	17.76
Flanges	<input type="checkbox"/> Yes <input checked="" type="checkbox"/> No	130	Quarterly monitoring	EPA	gas	0.08	5.18E-03	7.63
Loading	<input type="checkbox"/> Yes <input checked="" type="checkbox"/> No	2	Quarterly monitoring	EPA	gas	6.23	3.55E-02	1.38

Other equipment types may include compressor seals, relief valves, diaphragms, drains, meters, etc.

Please provide an explanation of the sources of fugitive emissions (e. g. pigging operations, equipment blowdowns, pneumatic controllers, etc.)

Please indicate if there are any closed vent bypasses (include component)

Specify all equipment used in the closed vent system (e. g. VRU, ERD, thief hatches, tanker truck loading, etc.)

Attachment K

Gas Well Affected Facility Data Sheet

ATTACHMENT K – GAS WELL AFFECTED FACILITY DATA SHEET

Complete this data sheet if you are the owner or operator of a gas well affected facility for which construction, modification or reconstruction commenced after August 23, 2011. This form must be completed for natural gas well affected facilities regardless of when flowback operations occur (or have occurred).

API Number	Date of Flowback	Date of Well Completion	Green Completion and/or Combustion Device
47-017-06266-00	10/20/2014	9/18/2014	Green
47-017-06169-00	9/7/2013	8/1/2014	Green
47-017-06170-00	9/1/2013	8/1/2014	Green
47-017-06236-00	Proposed	Proposed	Proposed
47-017-06206-00	10/20/2014	9/18/2014	Green
47-017-06668-00	8/15/2017	4/15/2017	Green
47-017-06667-00	8/15/2017	5/2/2017	Green
47-017-06665-00	8/15/2017	5/20/2017	Green
47-017-06666-00	8/15/2017	6/7/2017	Green
1 Proposed well			

Note: If future wells are planned and no API number is available please list as PLANNED. If there are existing wells that commenced construction prior to August 23, 2011, please acknowledge as existing.

This is the same API (American Petroleum Institute) well number(s) provided in the well completion notification and as provided to the WVDEP, Office of Oil and Gas for the well permit. The API number may be provided on the application without the state code (047).

Every oil and gas well permitted in West Virginia since 1929 has been issued an API number. This API is used by agencies to identify and track oil and gas wells.

The API number has the following format: 047-001-00001

Where,

*047 = State code. The state code for WV is 047.
 001 = County Code. County codes are odd numbers, beginning with 001 (Barbour) and continuing to 109 (Wyoming).
 00001 = Well number. Each well will have a unique well number.*

Attachment L

Storage Vessel Data Sheet

ATTACHMENT L – STORAGE VESSEL DATA SHEET

Complete this data sheet if you are the owner or operator of a storage vessel that contains condensate and/or produced water. This form must be completed for each new or modified bulk liquid storage vessel(s) that contains condensate and/or produced water. (If you have more than one (1) identical tank (i.e. 4-400 bbl condensate tanks), then you can list all on one (1) data sheet). **Include gas sample analysis, flashing emissions, working and breathing losses, USEPA Tanks, simulation software (ProMax, E&P Tanks, HYSYS, etc.), and any other supporting documents where applicable.**

The following information is REQUIRED:

- Composition of the representative sample used for the simulation
- For each stream that contributes to flashing emissions:
 - Temperature and pressure (inlet and outlet from separator(s))
 - Simulation-predicted composition
 - Molecular weight
 - Flow rate
- Resulting flash emission factor or flashing emissions from simulation
- Working/breathing loss emissions from tanks and/or loading emissions if simulation is used to quantify those emissions

Additional information may be requested if necessary.

GENERAL INFORMATION (REQUIRED)

1. Bulk Storage Area Name <p align="center">Tanks</p>	2. Tank Name: Condensate Tank 001-010
3. Emission Unit ID number: <p align="center">TANKCOND001-010</p>	4. Emission Point ID number. <p align="center">EP-EC001, EP-EC002, EP-EC003</p>
5. Date Installed, Modified or Relocated (for existing tanks) TANKCOND001-004:2013, TANKCOND005-007:2014, TANKCOND008-010:2015 Was the tank manufactured after August 23, 2011? <input checked="" type="checkbox"/> Yes <input type="checkbox"/> No	6. Type of change: <input checked="" type="checkbox"/> New construction <input type="checkbox"/> New stored material <input type="checkbox"/> Other <input type="checkbox"/> Relocation

7A. Description of Tank Modification (if applicable)

7B. Will more than one material be stored in this tank? If so, a separate form must be completed for each material.
 Yes No

7C. Was USEPA Tanks simulation software utilized?
 Yes No

If Yes, please provide the appropriate documentation and items 8-42 below are not required.

TANK INFORMATION

8. Design Capacity (specify barrels or gallons). Use the internal cross-sectional area multiplied by internal height. 400bbbls

9A. Tank Internal Diameter (ft): 12	9B. Tank Internal Height (or Length) (ft): 20
10A. Maximum Liquid Height (ft): 18	10B. Average Liquid Height (ft): 10
11A. Maximum Vapor Space Height (ft): 18	11B. Average Vapor Space Height (ft): 10

12. Nominal Capacity (specify barrels or gallons). This is also known as "working volume" and considers design liquid levels and overflow valve heights.: 400bbbls

13A. Maximum annual throughput (gal/yr): 9320640	13B. Maximum daily throughput (gal/day): 25536
14. Number of Turnovers per year (annual net throughput/maximum tank liquid volume): 56	15. Maximum tank fill rate (gal/min) 168

16. Tank fill method Submerged Splash Bottom Loading

17. Is the tank system a variable vapor space system? Yes No

If yes, (A) What is the volume expansion capacity of the system (gal)?
 (B) What are the number of transfers into the system per year?

18. Type of tank (check all that apply):

- Fixed Roof vertical horizontal flat roof cone roof dome roof other (describe)
- External Floating Roof pontoon roof double deck roof
- Domed External (or Covered) Floating Roof
- Internal Floating Roof vertical column support self-supporting
- Variable Vapor Space lifter roof diaphragm
- Pressurized spherical cylindrical
- other

ATTACHMENT L – STORAGE VESSEL DATA SHEET

PRESSURE/VACUUM CONTROL DATA

19. Check as many as apply:

- Does Not Apply
- Inert Gas Blanket of
- Vent to Vapor Combustion Device (vapor combustors, flares, thermal oxidizers, enclosed combustors)
- Conservation Vent (psig)
 - Vacuum _____ Pressure _____
- Emergency relief Valve (psig)
 - Vacuum _____ Pressure _____
- Thief Hatch Weighted Yes No

Complete appropriate Air Pollution Control Device Sheet

20. Expected Emission Rate (submit Test Data or Calculations here or elsewhere in the application).

Material Name	Flashing Loss		Breathing Loss		Working Loss		Total Emission Loss		Estimation Method
	lb/hr	tpy	lb/hr	tpy	lb/hr	tpy	lb/hr	tpy	

Please see Table 6 and Table 7

TANK CONSTRUCTION & OPERATION INFORMATION

21. Tank Shell Construction:

- Riveted Gunite lined Epoxy-coated Other (describe): Steel

21A. Shell Color: Green	21B. Roof Color: Green	21C. Year Last Painted	TANKCOND001-004:2013, TANKCOND005-007:2014, TANKCOND008-010:2015
-------------------------	------------------------	------------------------	--

22. Shell Condition (if metal and unlined):

- No Rust Light Rust Dense Rust Not applicable

22A. Is the tank beated? <input type="checkbox"/> Yes <input checked="" type="checkbox"/> No	22B. If yes, operating temperature:	22C. If yes, how is heat provided to tank?
---	-------------------------------------	--

23. Operating Pressure Range (psig): 0 psig, atmospheric

Must be listed for tanks using VRUs with closed vent system

24. Is the tank a Vertical Fixed Roof Tank? <input checked="" type="checkbox"/> Yes <input type="checkbox"/> No	24A. If yes, for dome roof provide radius (ft): NA	24B. If yes, for cone roof, provide slop (ft/ft): NA
--	--	--

25. Complete the following section for **Floating Roof Tanks** Does Not Apply

25A. Year Internal Floaters Installed:
25B. Primary Seal Type: <input type="checkbox"/> Metallic (mechanical) shoe seal <input type="checkbox"/> Liquid mounted resilient seal <input type="checkbox"/> Vapor mounted resilient seal <input type="checkbox"/> Other (describe):
25C. Is the Floating Roof equipped with a Secondary Seal? <input type="checkbox"/> Yes <input type="checkbox"/> No
25D. If YES, how is the secondary seal mounted? (check one) <input type="checkbox"/> Shoe <input type="checkbox"/> Rim <input type="checkbox"/> Other (describe)
25E. Is the Floating Roof equipped with a weather shield? <input type="checkbox"/> Yes <input type="checkbox"/> No
25F. Describe deck fittings

26. Complete the following section for Internal Floating Roof Tanks Does not apply

26A. Deck Type: <input type="checkbox"/> Bolted <input type="checkbox"/> Welded	26B. For bolted decks, provide deck construction		
26C. Deck seam: <input type="checkbox"/> 5 ft. wide <input type="checkbox"/> 6 ft. wide <input type="checkbox"/> 7 ft. wide <input type="checkbox"/> 5 x 7.5 ft wide <input type="checkbox"/> 5 x 12 ft wide <input type="checkbox"/> Other (describe)			
26D. Deck seam length (ft)	26E. Area of deck (ft ²)	26F. For column supported tanks: Number of columns:	26G. For column supported tanks, Diameter of each column:

27. Closed Vent System with VRU Yes No

28. Closed Vent System with Enclosed Combustor? Yes No

ATTACHMENT L – STORAGE VESSEL DATA SHEET

SITE INFORMATION

29. Provide the city and state on which the data in this section are based.: Charleston, WV	
30. Daily Average Ambient Temperature (°F): 65.07	31. Annual Average Maximum Temperature (°F): 75.94
32. Annual Average Minimum Temperature (°F): 46.55	33. Average Wind Speed (miles/hr): 18.5mph
34. Annual Average Solar Insulation Factor (BTU/(ft ² -day)) 1030.236	35. Atmospheric Pressure (psia): 14.8 (based off local conditions, could not find annual)

LIQUID INFORMATION

36. Average daily temperature range of bulk liquid (F): 65.08	36A. Minimum (°F): 46.56	36B. Maximum (°F): 75.94
37. Average operating pressure range of tank (psig): 0	37A. Minimum (psig): 0	37B. Maximum (psig): 0
38A. Minimum Liquid Surface Temperature (°F) 46.56	38B. Corresponding Vapor Pressure (psia) 1.85	
39A. Average Liquid Surface Temperature (°F) 65.08	39B. Corresponding Vapor Pressure (psia) 2.71	
40A. Maximum Liquid Surface Temperature (°F) 75.94	40B. Corresponding Vapor Pressure (psia) 3.34	

41. Provide the following for each liquid or gas to be stored in tank. Add additional pages if necessary.

41A. Material Name or Composition	Condensate		
41B. CAS Number	mix of HC		
41C. Liquid Density (lb/gal)	5.6800		
41D. Liquid Molecular Weight (lb/lb-mole)	87.90		
41E. Vapor Molecular Weight (lb/lb-mole)	45.0368		
Maximum Vapor Pressure	3.3419		
41F. True (psia)			
41G. Reid (psia)	4.4500		
Months Storage per Year	year round		
41H. From - To			

ATTACHMENT L – STORAGE VESSEL DATA SHEET

Complete this data sheet if you are the owner or operator of a storage vessel that contains condensate and/or produced water. This form must be completed for each new or modified bulk liquid storage vessel(s) that contains condensate and/or produced water . (If you have more than one (1) identical tank (i.e. 4-400 bbl condensate tanks), then you can list all on one (1) data sheet). **Include gas sample analysis, flashing emissions, working and breathing losses, USEPA Tanks, simulation software (ProMax, E&P Tanks, HYSYS, etc.), and any other supporting documents where applicable.**

The following information is REQUIRED:

- Composition of the representative sample used for the simulation
- For each stream that contributes to flashing emissions:
 - Temperature and pressure (inlet and outlet from separator(s))
 - Simulation-predicted composition
 - Molecular weight
 - Flow rate
- Resulting flash emission factor or flashing emissions from simulation
- Working/breathing loss emissions from tanks and/or loading emissions if simulation is used to quantify those emissions

Additional information may be requested if necessary.

GENERAL INFORMATION (REQUIRED)

1. Bulk Storage Area Name Tanks	2. Tank Name: Produced Water Tank 001-002
3. Emission Unit ID number: TANKPW001-002	4. Emission Point ID number. EP-EC001, EP-EC002, EP-EC003
5. Date Installed , Modified or Relocated (for existing tanks) 2013 Was the tank manufactured after August 23, 2011? <input checked="" type="checkbox"/> Yes <input type="checkbox"/> No	6. Type of change: <input checked="" type="checkbox"/> New construction <input type="checkbox"/> New stored material <input type="checkbox"/> Other <input type="checkbox"/> Relocation
7A. Description of Tank Modification (if applicable)	
7B. Will more than one material be stored in this tank? If so, a separate form must be completed for each material. <input type="checkbox"/> Yes <input checked="" type="checkbox"/> No	

7C. Was USEPA Tanks simulation software utilized?
 Yes No

If Yes, please provide the appropriate documentation and items 8-42 below are not required.

TANK INFORMATION

8. Design Capacity (specify barrels or gallons). Use the internal cross-sectional area multiplied by internal height. 400bbbs	
9A. Tank Internal Diameter (ft): 12	9B. Tank Internal Height (or Length) (ft): 20
10A. Maximum Liquid Height (ft): 18	10B. Average Liquid Height (ft): 10
11A. Maximum Vapor Space Height (ft): 18	11B. Average Vapor Space Height (ft): 10
12. Nominal Capacity (specify barrels or gallons). This is also known as "working volume" and considers design liquid levels and overflow valve heights.: 400bbbs	
13A. Maximum annual throughput (gal/yr): 7511700	13B. Maximum daily throughput (gal/day): 20580
14. Number of Turnovers per year (annual net throughput/maximum tank liquid volume): 224	15. Maximum tank fill rate (gal/min): 168
16. Tank fill method <input type="checkbox"/> Submerged <input checked="" type="checkbox"/> Splash <input type="checkbox"/> Bottom Loading	

17. Is the tank system a variable vapor space system? Yes No

If yes, (A) What is the volume expansion capacity of the system (gal)?
(B) What are the number of transfers into the system per year?

18. Type of tank (check all that apply):

- Fixed Roof vertical horizontal flat roof cone roof dome roof other (describe)
- External Floating Roof pontoon roof double deck roof
- Domed External (or Covered) Floating Roof
- Internal Floating Roof vertical column support self-supporting
- Variable Vapor Space lifter roof diaphragm
- Pressurized spherical cylindrical

ATTACHMENT L – STORAGE VESSEL DATA SHEET

PRESSURE/VACUUM CONTROL DATA

19. Check as many as apply:

- Does not apply Rupture Disc (psig)
- Inert Gas Blanket Carbon Adsorption
- Vent to Vapor Combustion Device (vapor combustors, flares, thermal oxidizers, enclosed combustors)
- Conservation Vent (psig)

Vacuum	Pressure
--------	----------
- Emergency relief Valve (psig)

Vacuum	Pressure
--------	----------
- Thief Hatch Weighted Yes No

Complete appropriate Air Pollution Control Device Sheet

20. Expected Emission Rate (submit Test Data or Calculations here or elsewhere in the application).

Material Name	Flashing Loss		Breathing Loss		Working Loss		Total Emission Loss		Estimation Method
	lb/hr	tpy	lb/hr	tpy	lb/hr	tpy	lb/hr	tpy	
Please see Table 6 and Table 7									

TANK CONSTRUCTION & OPERATION INFORMATION

21. Tank Shell Construction:

- Riveted Gunite lined Epoxy- Other(describe): Steel

21A. Shell Color: Green 21B. Roof Color: Green 21C. Year Last Painted: 2013

22. Shell Condition (if metal and unlined):

- No Rust Light Rust Dense Rus: Not applicable

22A. Is the tank heated?

- Yes No

22B. If yes, operating temperature:

22C. If yes, how is heat provided to tank?

23. Operating Pressure Range (psig): 0 psig, atmospheric

Must be listed for tanks using VRUs with closed vent system

24. Is the tank a Vertical Fixed Roof Tank?

- Yes No

24A. If yes, for dome roof provide radius (ft): NA

24B. If yes, for cone roof, provide slop (ft/ft): NA

25. Complete the following section for **Floating Roof Tanks** Does Not Apply

25A. Year Internal Floaters Installed:

25B. Primary Seal Type:

- Metallic (mechanical) shoe seal Liquid mounted
- Vapor mounted resilient seal Other (describe):

25C. Is the Floating Roof equipped with a Secondary Seal?

- Yes No

25D. If YES, how is the secondary seal mounted? (check one)

- Shoe Rim Other(describe):

25E. Is the Floating Roof equipped with a weather shield?

- Yes No

25F. Describe deck fittings

26. Complete the following section for Internal Floating Roof Tanks Does not apply

26A. Deck Type:

- Bolted Welded

26B. For bolted decks, provide deck construction

26C. Deck seam:

- 5 ft. wide 6 ft. wide 7 ft. wide 5 x 7.5 ft. wide 5 x 12 ft. wide Other

26D. Deck seam length (ft)

26E. Area of deck (ft2)

26F. For column supported tanks:
Number of columns:

26G. For column supported tanks,
Diameter of each column:

27. Closed Vent System with VRU

- Yes No

28. Closed Vent System with Enclosed Combustor?

- Yes No

ATTACHMENT L – STORAGE VESSEL DATA SHEET

SITE INFORMATION			
29. Provide the city and state on which the data in this section are based.: Charleston, WV			
30. Daily Average Ambient Temperature (°F): 65.07		31. Annual Average Maximum Temperature (°F): 75.94	
32. Annual Average Minimum Temperature (°F): 46.55		33. Average Wind Speed (miles/hr): 5.9mph	
34. Annual Average Solar Insulation Factor (BTU/(ft ² ·day))		1030.236	35. Atmospheric Pressure (psia): 14.8 (based off local conditions, could not find annual)
LIQUID INFORMATION			
36. Average daily temperature range of bulk liquid (F):	65.08	36A. Minimum (°F):	46.56
		36B. Maximum (°F)	75.94
37. Average operating pressure range of tank (psig):	0	37A. Minimum (psig)	0
		37B. Maximum (psig)	0
38A. Minimum Liquid Surface Temperature (°F)	46.56	38B. Corresponding Vapor Pressure (psia)	0.22
39A. Average Liquid Surface Temperature (°F)	65.08	39B. Corresponding Vapor Pressure (psia)	0.37
40A. Maximum Liquid Surface Temperature (°F)	75.94	40B. Corresponding Vapor Pressure (psia)	0.49
41. Provide the following for <u>each</u> liquid or gas to be stored in tank. Add additional pages if necessary.			
41A. Material Name or Composition	Produced Water		
41B. CAS Number	mix of HC and water		
41C. Liquid Density (lb/gal)	8.3300		
41D. Liquid Molecular Weight (lb/lb-mole)	18.02		
41E. Vapor Molecular Weight (lb/lb-mole)	18.5442		
Maximum Vapor Pressure	0.4927		
41F. True (psia)			
41G. Reid (psia)	1.0236		
Months Storage per Year	year round		
41H. From - To			

Attachment M
Natural Gas Fired Fuel Burning Unit(s)
Data Sheet

**ATTACHMENT M – SMALL HEATERS AND REBOILERS NOT SUBJECT TO
40CFR60 SUBPART DC
DATA SHEET**

Complete this data sheet for each small heater and reboiler not subject to 40CFR60 Subpart Dc at the facility. *The Maximum Design Heat Input (MDHI) must be less than 10 MMBTU/hr.*

Emission Unit ID#	Emission Point ID#	Emission Unit Description (Manufacturer, model#)	Year Installed/Modified	Type and Date of Change	Maximum Design Heat Input (MMBTU/hr)	Fuel Heating Value (BTU/scf)
GPU001	EP-GPU001	Gas Production Unit Heater	2013	Existing	1.5	1218.948
GPU002	EP-GPU002	Gas Production Unit Heater	2013	Existing	1.5	1218.948
GPU003	EP-GPU003	Gas Production Unit Heater	2013	Existing	1.5	1218.948
GPU004	EP-GPU004	Gas Production Unit Heater	2014	Existing	1.5	1218.948
GPU005	EP-GPU005	Gas Production Unit Heater	2014	Existing	1.5	1218.948
GPU006	EP-GPU006	Gas Production Unit Heater	2014	Existing	1.5	1218.948
GPU007	EP-GPU007	Gas Production Unit Heater	2014	Existing	1.5	1218.948
GPU008	EP-GPU008	Gas Production Unit Heater	2014	Existing	1.5	1218.948
GPU009	EP-GPU009	Gas Production Unit Heater	2014	Existing	1.5	1218.948
GPU010	EP-GPU010	Gas Production Unit Heater	2014	Existing	1.5	1218.948
LH001	EP-LH001	Line Heater	2016	New	2	1218.948
LH002	EP-LH002	Line Heater	2016	New	2	1218.948
LH003	EP-LH003	Line Heater	2016	New	2	1218.948
LH004	EP-LH004	Line Heater	2016	New	2	1218.948
LH005	EP-LH005	Line Heater	2016	New	2	1218.948
LH006	EP-LH006	Line Heater	2016	New	2	1218.948
LH007	EP-LH007	Line Heater	2016	New	2	1218.948
LH008	EP-LH008	Line Heater	2016	New	2	1218.948
LH009	EP-LH009	Line Heater	2016	New	2	1218.948
LH010	EP-LH010	Line Heater	2016	New	2	1218.948

1. Enter the appropriate Emission Unit (or Source) identification number for each fuel burning unit located at the production pad. Gas Producing Unit Burners should be designated GPU-1, GPU-2, etc. Heater Treaters should be designated HT-1, HT-2, etc. Heaters or Line Heaters should be designated LH-1, LH-2, etc. For sources, use 1S, 2S, 3S...or other appropriate designation. Enter glycol dehydration unit Reboiler Vent data on the Glycol Dehydration Unit Data Sheet.
2. Enter the appropriate Emission Point identification numbers for each fuel burning unit located at the production pad. Gas Producing Unit Burners should be designated GPU-1, GPU-2, etc. Heater Treaters should be designated HT-1, HT-2, etc. Heaters or Line Heaters should be designated LH-1, LH-2, etc. For emission points, use 1E, 2E, 3E...or other appropriate designation.
3. New, modification, removal.
4. Enter design heat input capacity in MMBtu/hr.
5. Enter the fuel heating value in BTU/standard cubic foot.

Attachment N

Internal Combustion Engine Data Sheet

ATTACHMENT N – INTERNAL COMBUSTION ENGINE DATA SHEET

Complete this data sheet for each internal combustion engine at the facility. Include manufacturer performance data sheet(s) or any other supporting document if applicable. Use extra pages if necessary. *Generator(s) and microturbine generator(s) shall also use this form.*

Emission Unit ID#		ENG001					
Engine Manufacturer/Model		Engine (Kubota DG972-E2)					
Manufacturers Rated bhp/rpm		24 HP @ 3600 rpm					
Source Status		ES					
Date Installed/ Modified/ Removed/ Relocated		2014					
Engine Manufacturer/ Reconstruction Date		2013					
Check all applicable Federal Rules for the engine (include EPA Certification of Conformity if applicable)		<input checked="" type="checkbox"/> 40CFR60 Subpart JJJJ <input checked="" type="checkbox"/> JJJJ Certified? <input type="checkbox"/> 40CFR60 Subpart IIII <input type="checkbox"/> IIII Certified? <input checked="" type="checkbox"/> 40CFR63 Subpart ZZZZ <input type="checkbox"/> NESHAP ZZZZ/NSPS JJJJ Window <input type="checkbox"/> NESHAP ZZZZ Remote Sources	<input type="checkbox"/> 40CFR60 Subpart JJJJ <input type="checkbox"/> JJJJ Certified? <input type="checkbox"/> 40CFR60 Subpart IIII <input type="checkbox"/> IIII Certified? <input type="checkbox"/> 40CFR63 Subpart ZZZZ <input type="checkbox"/> NESHAP ZZZZ/NSPS JJJJ Window <input type="checkbox"/> NESHAP ZZZZ Remote Sources	<input type="checkbox"/> 40CFR60 Subpart JJJJ <input type="checkbox"/> JJJJ Certified? <input type="checkbox"/> 40CFR60 Subpart IIII <input type="checkbox"/> IIII Certified? <input type="checkbox"/> 40CFR63 Subpart ZZZZ <input type="checkbox"/> NESHAP ZZZZ/NSPS JJJJ Window <input type="checkbox"/> NESHAP ZZZZ Remote Sources			
Engine Type		4SRB					
APCD Type		NSCR					
Fuel Type		RG					
H2S (gr/ 100 scf)		0					
Operating bhp/rpm		16.5 HP @ 2400 rpm					
BSFC (BTU/bhp-hr)		9773					
Hourly Fuel Throughput (Must use 8,760 hrs/yr unless emergency generator)		193 ft ³ /hr gal/hr					ft ³ /hr gal/hr
Fuel Usage or Hours of Operation Metered		1.6907 MMft ³ /yr gal/yr					MMft ³ /yr gal/yr
Calculation Methodology	Pollutant	Hourly PTE (lb/hr)	Annual PTE (tons/year)	Hourly PTE (lb/hr)	Annual PTE (tons/year)	Hourly PTE (lb/hr)	Annual PTE (tons/year)
MD	NOx	0.3158	1.3831				
MD	CO	5.6445	24.7228				
AP	VOC	0.0069	0.0304				
AP	SO2	0.0001	0.0006				
AP	PM10	0.0022	0.0098				
AP	Formaldehyde	0.0048	0.0211				
AP	Total HAPs	0.0054	0.0236				
OT	GHG (CO2e)	27.1504	118.9186				



UNITED STATES ENVIRONMENTAL PROTECTION AGENCY
2013 MODEL YEAR
CERTIFICATE OF CONFORMITY
WITH THE CLEAN AIR ACT OF 1990

OFFICE OF TRANSPORTATION
AND AIR QUALITY
ANN ARBOR, MICHIGAN 48105

Certificate Issued To: Kubota Corporation
(U.S. Manufacturer or Importer)
Certificate Number: DKBXS.9622HP-002

Effective Date:
11/20/2012
Expiration Date:
12/31/2013

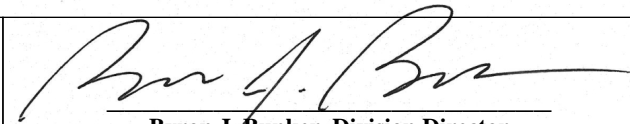
Byron J. Bunker, Division Director
Compliance Division

Issue Date:
11/20/2012
Revision Date:
N/A

Manufacturer: Kubota Corporation
Engine Family: DKBXS.9622HP
Certificate Number: DKBXS.9622HP-002
Useful Life : 1000 Hours / 5 Years
Engine Class : Nonhandheld-Class II
Fuel : Natural Gas (CNG/LNG)
Emission Standards : NMHC + NO_x (g/kW-hr) : 8
CO (g/kW-hr) : 610

Pursuant to Section 213 of the Clean Air Act (42 U.S.C. section 7547), 40 CFR Part 1054, 40 CFR Part 1068 and 40 CFR Part 60 (stationary only and combined stationary and mobile), and subject to the terms and conditions prescribed in those provisions, this certificate of conformity is hereby issued for the following small nonroad engine family, more fully described in the documentation required by 40 CFR Part 1054 and produced in the stated model year.

This certificate of conformity covers only those new small nonroad engines which conform in all material respects to the design specifications that applied to those engines described in the documentation required by 40 CFR Part 1054 and which are produced during the model year stated on this certificate of the said manufacturer, as defined in 40 CFR Part 1054. This certificate of conformity does not cover small nonroad engines imported prior to the effective date of the certificate.

It is a term of this certificate that the manufacturer shall consent to all inspections described in 40 CFR 1068.20 and 1068, Subpart E and authorized in a warrant or court order. Failure to comply with the requirements of such a warrant or court order may lead to revocation or suspension of this certificate for reasons specified in 40 CFR Part 1054. It is also a term of this certificate that this certificate may be revoked or suspended or rendered void *ab initio* for other reasons specified in 40 CFR Part 1054, 40 CFR Part 1068.

This certificate does not cover small nonroad engines sold, offered for sale, or introduced, or delivered for introduction, into commerce in the U.S. prior to the effective date of the certificate.

TECHNICAL INFORMATION

DG972-SAEH-S1

NATURAL GAS FUEL ENGINE

July, 2006

KUBOTA Corporation

CONTENTS

1. GENERAL SPECIFICATIONS

2. PERFORMANCE CURVES

3. DIMENSIONS

4. TECHNICAL DATA

4-1) BRAKE HORSE POWER

4-2) FUEL CONSUMPTION

4-3) NOISE LEVEL

4-4) AIR REQUIREMENTS

1. Combustion air requirements
2. Cooling air requirements
3. Combustion and cooling air requirements

4-5) EXHAUST GAS VOLUME

4-6) HEAT REJECTION TO COOLING WATER (Ho)

4-7) COOLING FAN DATA

4-8) CENTER OF GRAVITY

4-9) UNBALANCED FORCES OF ENGINES

4-10) MASS ELASTIC SYSTEM

5. FUEL SYSTEM AND FUEL DIAGRAM

Specifications and dimensions are subject to change without prior notice.

1. GENERAL SPECIFICATIONS

ITEM	UNIT	SPECIFICATIONS
Engine model		DG972-SAEH-S1
Type		Vertical, In line, 4cycle Natural Gas engine
Cooling system		Water cooling with water pump
Number of cylinders		3
Cylinder bore	mm(in)	74.5 (2.93)
Stroke	mm(in)	73.6 (2.90)
Total displacement	L(cu. in)	0.962 (58.7)
High idle	rpm	3850
Low idle	rpm	1500
Horsepower	kW(HP)	19.5(26.1)
Max. torque (SAE J1349)	Nm(ft-lb) /rpm	61.2 (45.2)/2400
Compression ratio		9.2
Firing order		1-2-3
Ignition timing		B.T.D.C.15° /1000rpm B.T.D.C.28° /3600rpm
Ignition system		Distributor-less Solid State type
Fuel		Natural Gas only
Direction of rotation		Counter-clockwise from flywheel side
Starting system		Electric starting with cell starter
Starter output	V-kW	12-1.0
Alternator output	V-W	12-480 (Standard)
Lubricating system		Forced lubricating by trochoid pump
Lubricating oil		Quality better than SH class
Lube. oil capacity	L(US gal)	3.4 (0.90)
Coolant capacity	L(US gal)	1.22 (0.32)
Governor type		Centrifugal flyweight mechanical type governor
Dimensions (LxBxH)	mm(in)	526x415x503 (20.7x16.3x19.8)
Dry weight	kg(lb)	Approx. 95.4(210)
Application		Stationary only

2. PERFORMANCE CURVES

DG972 PERFORMANCE CURVES

Higher calorific value : 11000kcal/m³ (1236BTU/ft³)

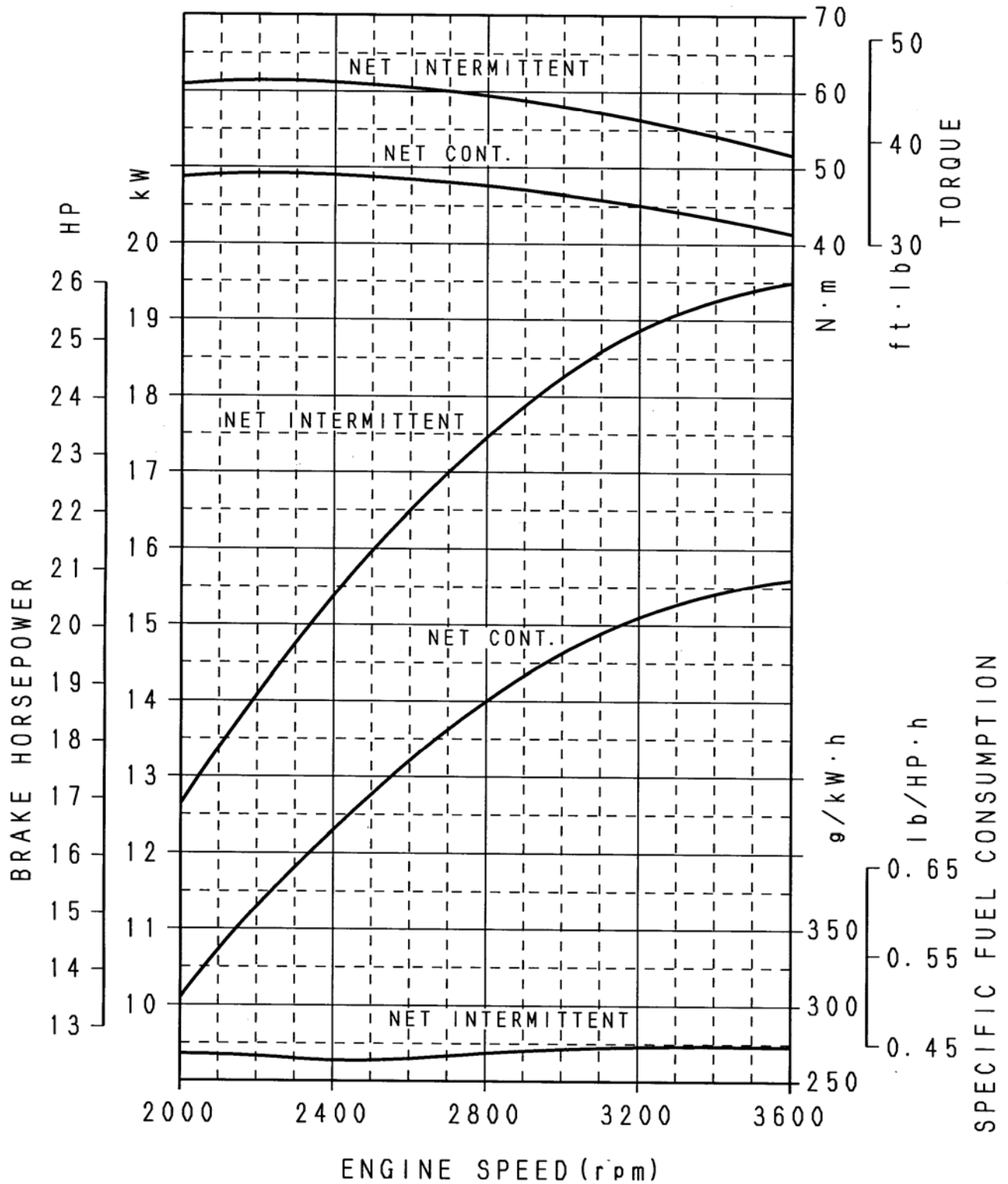

3. DIMENSIONS

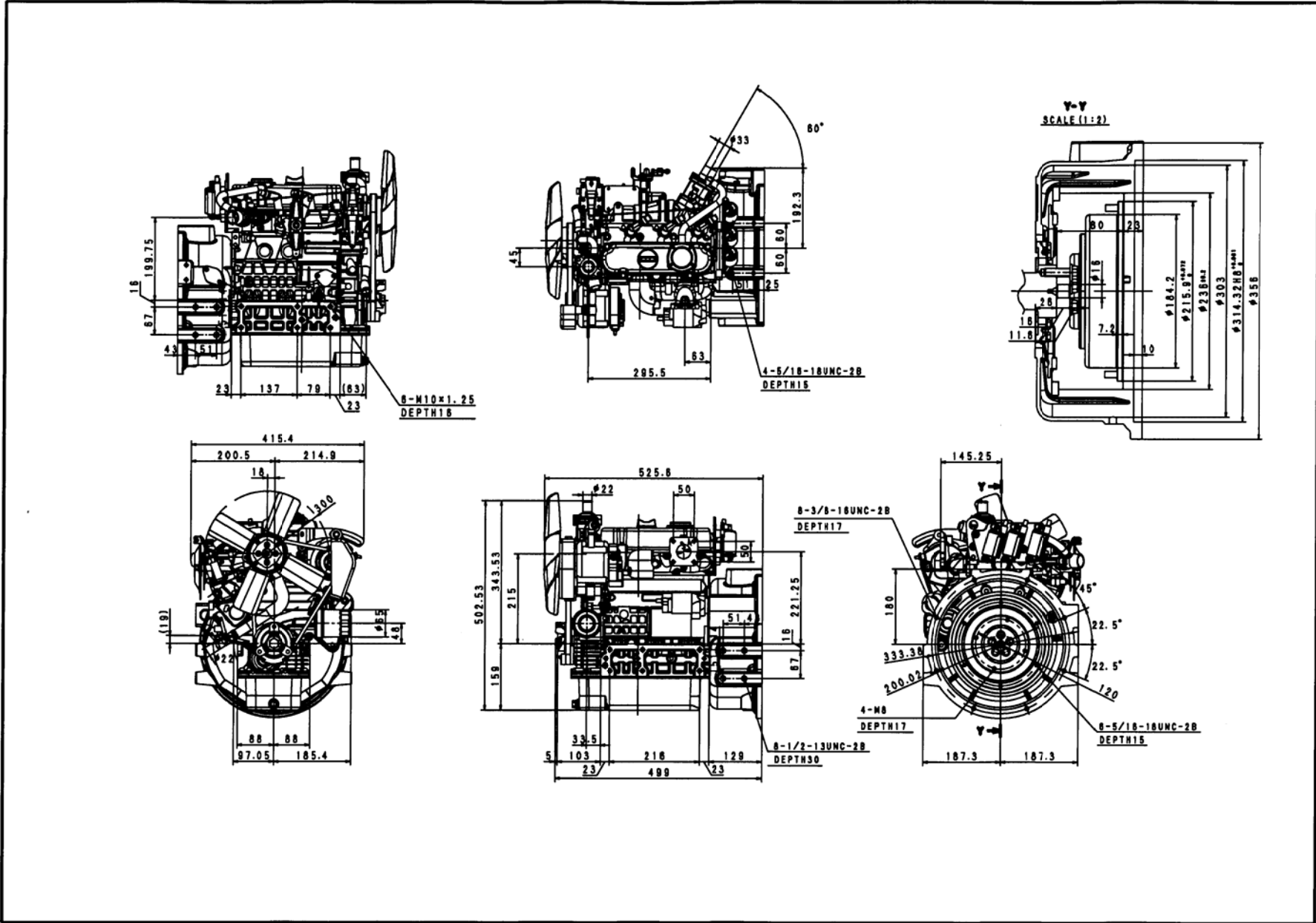

4. TECHNICAL DATA

ITEM		SPECIFICATIONS	
Engine model		DG972-SAEH-S1	
Brake horse power		See attached sheet	4-1)
Top Clearance		1.35 to 1.65mm (0.05315 to 0.06496in)	
Compression pressure		1.32MPa (192psi)	
Fuel consumption		See attached sheet	4-2)
Lube. oil consumption		Max.0.67g/kWh (0.5g/HPh) at rated load	
Lube. oil pressure		at idling speed: more than 69kPa (more than 9.95psi)	
		at rated speed: 196 to 441kPa (28.44 to 63.99psi)	
Noise level		See attached sheet	4-3)
Combustion air requirements		See attached sheet (Refer to 25deg.C and 1000hPa)	
Cooling air requirements			
Combustion and cooling air requirements			
Exhaust gas volume		See attached sheet (Refer to 25deg.C and 1000hPa)	4-5)
Cold starting limits		-15deg.C (5deg.F)	
Heat rejection		See attached sheet	4-6)
Angles of tilt	Front or Rear down	30° (Less than 10min. continuous operation)	
		20° (Continuous operation)	
	Left or Right side down	30° (Less than 10min. continuous operation)	
		20° (Continuous operation)	
Valve timing		[Inlet valve] Open: TDC -20° Close: BDT +45°	
		[Exhaust valve] Open: BDC -50° Close: TDC +15°	
Cooling fan data		See attached sheet	4-7)
Center of gravity		See attached sheet	4-8)
Unbalanced forces of engines		See attached sheet	4-9)
Mass elastic system		See attached sheet	4-10)
Thermostat specifications		Opening temperature: 71±1.5deg.C (159.8±2.7deg.F)	
		Fully opened temperature: 85deg.C (185deg.F) [at Thermostat lift:8mm (0.31in)]	

4-1) BRAKE HORSE POWER

SAE J1349

Engine speed	rpm	2000	2400	2800	3200	3600
Net intermittent	kW	12.6	15.4	17.4	18.9	19.5
	HP	16.9	20.6	23.3	25.3	26.1
	PS	17.1	20.9	23.7	25.7	26.5
Net continuous	kW	10.1	12.3	13.9	15.1	15.6
	HP	13.5	16.5	18.7	20.3	20.9
	PS	13.7	16.8	18.9	20.6	21.2

Note

- Conversion rates
 $1\text{kW}=1.35962\text{PS}=1.34048\text{HP}$
 $1\text{PS}=0.7355\text{kW}=0.985925\text{HP}$
 $1\text{HP}=0.7457\text{kW}=1.01428\text{PS}$
- Fuel detail
 Japanese standard gas
 higher calorific value : 11000kcal/m^3 (1236BTU/ft^3)
 supply pressure : $0.98 - 2.45\text{kPa}$ ($7.35 - 18.38\text{mmHg}$)

4-2) FUEL CONSUMPTION

Specific at net intermittent (SAE J1349)

Engine speed	rpm	2000	2400	2800	3200	3600
Brake horse power	kW	12.6	15.4	17.4	18.9	19.5
	HP	16.9	20.6	23.3	25.3	26.1
	PS	17.1	20.9	23.7	25.7	26.5
Fuel consumption	g/kWh	269	264	269	273	273
	g/HPh	200	197	200	204	204
	g/PSh	198	194	198	201	201
	lb/HPh	0.442	0.434	0.442	0.449	0.449

Note

- Conversion rates
 $1\text{kW}=1.35962\text{PS}=1.34048\text{HP}$ $1\text{kg}=2.20462\text{lb}$ ($1\text{g}=0.00220462\text{lb}$)
 $1\text{PS}=0.7355\text{kW}=0.985925\text{HP}$ $1\text{lb}=0.45359\text{kg}$
 $1\text{HP}=0.7457\text{kW}=1.01428\text{PS}$
- Fuel detail
 Japanese standard gas
 higher calorific value : 11000kcal/m^3 (1236BTU/ft^3)
 supply pressure : $0.98 - 2.45\text{kPa}$ ($7.35 - 18.38\text{mmHg}$)

4-3) NOISE LEVEL

Load × rpm	Unit	Sound pressure at 1m(3.3ft)
0/4 × 3850	dB(A)	90.0
4/4 × 3850 15.6kW (20.9HP)	dB(A)	92.0
0/4 × 1500	dB(A)	72.0

These data show the average noise level at four points.

Note

- Measurement conditions : With radiator, cooling fan, air cleaner and muffler.

4-4) AIR REQUIREMENTS

1. Combustion air requirements (Refer to 25deg.C and 1000hPa)

rpm	2000	2400	2800	3200	3600
L/sec	12.35	14.81	17.28	19.75	22.22
m ³ /h	44.44	53.33	62.22	71.11	80.00
in ³ /sec	753	904	1055	1205	1356
ft ³ /min	26.13	31.35	36.58	41.80	47.03

Combustion air requirements calculating formula

$$Q_1 = V_h \cdot N \cdot C \cdot \eta \cdot 10^{-3}$$

Q₁: Amount of intake air (m³/min)

η: Intake efficiency

V_h: Total displacement (L)

Natural Gas: 0.77

N: Engine speed (rpm)

C: Coefficient=0.5

2. Cooling air requirements (Refer to 25deg.C and 1000hPa)

rpm	2000	2400	2800	3200	3600
L/sec	571.2	737.2	824.7	833.9	764.7
m ³ /h	2056	2654	2969	3002	2753
in ³ /sec	34859	44984	50327	50888	46667
ft ³ /min	1210.2	1561.8	1747.3	1766.7	1620.2

Above data is decided by following conditions.

1. Using the standard radiator.
2. Engine is run as open unit.

3. Combustion and cooling air requirements (Refer to 25deg.C and 1000hPa)

rpm	2000	2400	2800	3200	3600
L/sec	583.5	752.0	842.0	853.7	786.9
m ³ /h	2100.4	2707.3	3031.2	3073.1	2833.0
in ³ /sec	35612	45888	51382	52093	48023
ft ³ /min	1236.3	1593.2	1783.9	1808.5	1667.2

Note

1. Cooling fan and fan pulley specifications(Cooling fan Part No. 15881-74112)

Item	
Fan diameter	300mm (11.81in)
No. of blade and type of shape	4, S type
Diameter of fan driving pulley	100mm (3.94in)
Diameter of fan pulley	84mm (3.31in)

2. Conversion rates

$$1L = 61.0237 \text{ in}^3 = 0.035315 \text{ ft}^3$$

$$1 \text{ ft}^3 = 28.3168 \text{ L}$$

$$1 \text{ L/sec} = 3.6 \text{ m}^3/\text{h} = 2.1189 \text{ ft}^3/\text{min}$$

4-5) EXHAUST GAS VOLUME

Refer to 25deg.C and 1000hPa

rpm	2000	2400	2800	3200	3600
L/sec	35.46	42.55	49.65	56.74	63.83
m ³ /h	127.67	153.19	178.73	204.26	229.80
in ³ /sec	2164	2597	3030	3462	3895
ft ³ /min	75.05	90.06	105.07	120.08	135.09

Note

- Conversion rates
 - 1L=61.0237in³=0.035315ft³
 - 1ft³=28.3168L
 - 1L/sec=3.6m³/h=127.133ft³/hr

4-6) HEAT REJECTION TO COOLING WATER

1. Specific at net intermittent (SAE J1349)

Engine speed	rpm	2000	2400	2800	3200	3600
Brake horse power	kW	12.6	15.4	17.4	18.9	19.5
	HP	16.9	20.6	23.3	25.3	26.1
	PS	17.1	20.9	23.7	25.7	26.5
Fuel consumption	g/kWh	269	264	269	273	273
	g/HPh	200	197	200	204	204
	g/PSh	198	194	198	201	201
	lb/HPh	0.442	0.434	0.442	0.449	0.449
Heat rejection to cooling water	MJ/h	29.05	31.52	38.79	45.13	51.82
	kcal/h	6940	7529	9267	10781	12379
	BTU/h	12491	13551	16679	19404	22281

Note

Heat rejection to cooling water calculating formula

$$Ho=Hu \cdot Ne \cdot be \cdot i$$

Ho: Heat rejection to cooling water

Hu: Fuel low calorific value

Japanese standard gas; 49.4MJ/kg, 11800kcal/h, 212391BTU/lb

Ne: Brake horse power

Be: Specific fuel consumption

i: Dispersion ratio to cooling water

4-7) COOLING FAN DATA

1. Performance curves <P-Q>

- Part No. 15881-74110 (Applicable for DG972)

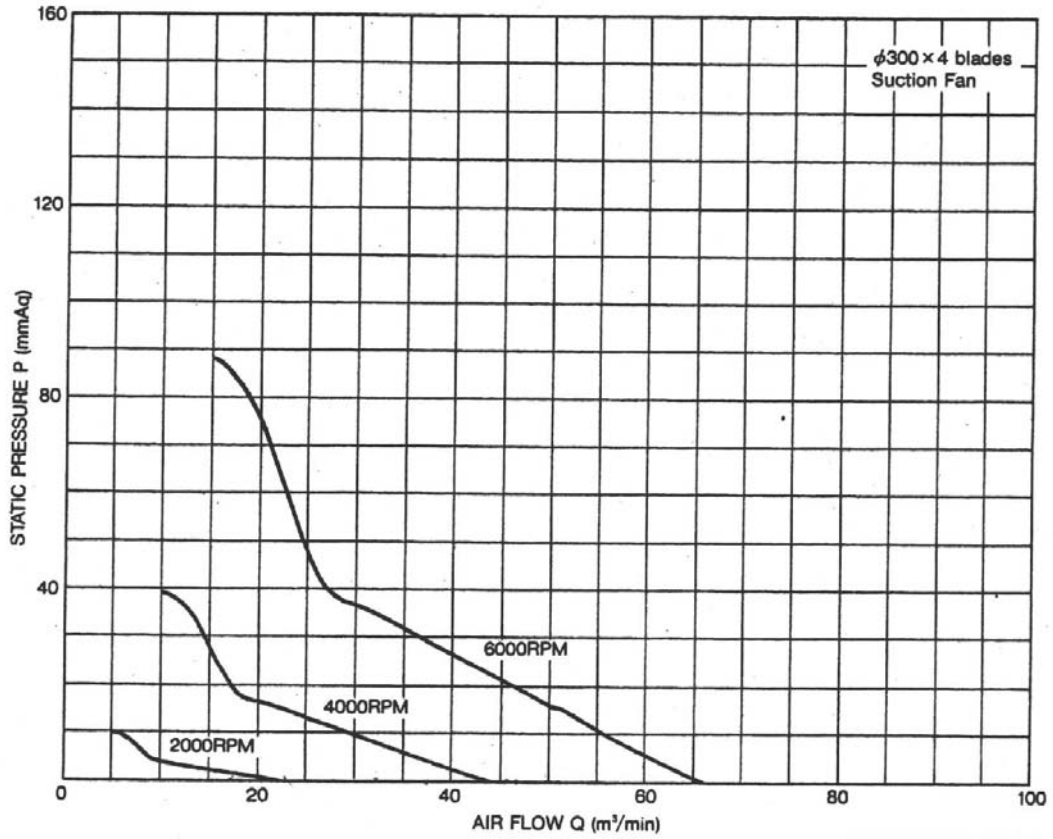

4-8) CENTER OF GRAVITY

1. With standard flywheel and rear-end plate

Model	Dry weight kg (lb)	Center of gravity		
		X mm (in)	Y mm (in)	Z mm (in)
WG/DF972	72.0 (159)	-25.5 (-1.00)	73.3 (2.89)	179.5 (7.07)

2. With SAE flywheel and flywheel housing

Model	Dry weight kg (lb)	Center of gravity		
		X mm (in)	Y mm (in)	Z mm (in)
DG972 -SAEH-S1	95.4 (210)	-10.0 (0.39)	28.0 (1.10)	207.0 (8.15)

Note

Cooling water and lubricating oil weight is not included in above engine weight.

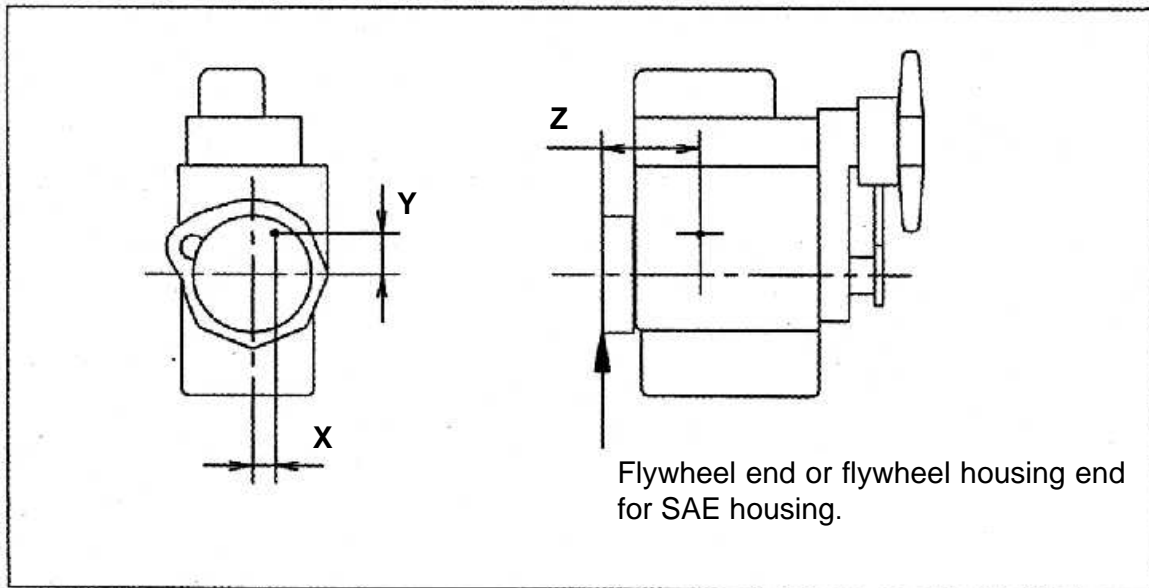

4-9) UNBALANCED FORCES OF ENGINES

1. Base data

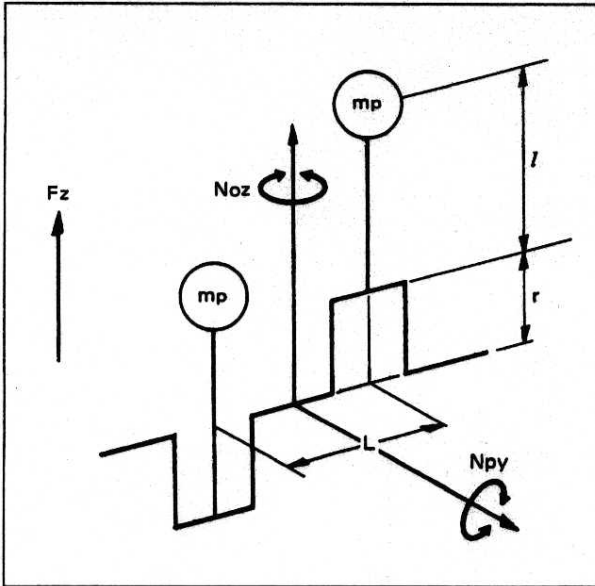

F_z : Unbalanced inertia force
 N_{py} , N_{oz} : Unbalanced inertia couple
 m_p : Reciprocating mass
 r : Crank radius
 l : Center distance of connecting rod
 L : Cylinder distance
 ω : Angular velocity

$\omega = 2\pi n / 60$	n : Engine speed (rpm)
------------------------	--------------------------

$l = 0.098\text{m}$	Cylinder bore (mm)	m_p (kg)
$r = 0.0368\text{m}$	74.5	0.37/9.80665
$L = 0.080\text{m}$		

2. Unbalanced inertia force and couple

($\times \omega^2$)

Model	No. of Cylinder	Cylinder Bore	Order	F_z	N_{py}	N_{oz}
WG/DF/DG 972	3	74.5mm	1	0	0.000096	0.000096
			2	0	0.000072	0

▼An example of calculation

Calculation condition	ω^2	F_z, N_{py}, N_{oz}		
		Order	Calculation	
Engine model DG972 Engine speed 3600(rpm)	$[2 \times \pi \times 3600/60]^2 = 142122$	F_z	1	0
			2	0
		N_{py}	1	$0.000096 \times 142122 = 13.6\text{kg}$
			2	$0.000072 \times 142122 = 10.2\text{kg}$
		N_{oz}	1	$0.000096 \times 142122 = 13.6\text{kg}$
			2	0

4-10) MASS ELASTIC SYSTEM

Equivalent torsional vibration data

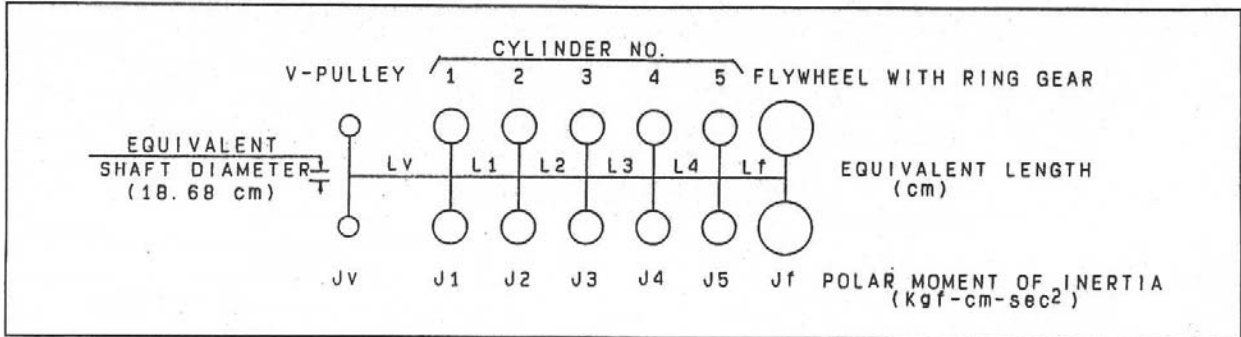

MODEL	EQUIVALENT LENGTH (cm)				POLAR MOMENT OF INERTIA (kgf-cm-sec ²)				
	LV	L1	L2	Lf	JV	J1	J2	J3	Jf
DG972 -SAEH-S1	35082	4528	4528	2824	0.013	0.026	0.026	0.026	1.281

Note: Flywheel E8052-25110, V-Pulley 16861-74280

5. FUEL SYSTEM AND FUEL DIAGRAM

- All fuel connections added to this engine must be installed by qualified personnel utilizing recognized procedures and standards.
- These non-KUBOTA installed parts, such as hoses, shutoff solenoid valve should be approved for Natural gas use.
- An approved, listed fuel filter and shutoff solenoid valve must be installed between the gas tank and Kubota regulator.
- Two fuel cut solenoids must be installed in series before the regulator on the fuel supply line for safety (backup) purpose.

1. Tightening torque and leak check

- 1) The joint must be installed to the gas entrance of the regulator by screw with O-ring. Screw is tightened to the specified torque using a driver, and leak check must be performed as shown in the below table.
- 2) The connector on the gas mixer may be mounted on any position since it is not sealed. The lock nut may be loosened using a wrench. The connector may be changed to any specified angle. The lock nut should be tightened to the specified torque using a wrench as shown in the below table.

[TIGHTENING TORQUE AND LEAK CHECK]

	Qty.	Size	Tightening torque			Leak check pressure
			Nm	kgfm	ft-lb	
SCREW	2	M4	1.9 to 2.9	0.2 to 0.3	1.5 to 2.2	Soap solution or its equivalent
LOCK NUT	1	M16 × 1	19.6 to 39.2	2.0 to 4.0	14.5 to 28.9	

2. Setting of the regulator

- 1) Install the regulator in **UPRIGHT** position, it must be installed within 4G vibration level. If not, it may not supply necessary fuel to the engine.
- 2) **DO NOT** connect any extension hose to the air vent pipe of the regulator. This may cause an improper supply of fuel to the engine.

3. Caution for FUEL SYSTEM

The standard engine is equipped with $\phi 6.6$ jet for the fuel calorific gas value of 11000kcal/m³ (1236BTU/ft³).

When the engine is operated with the different calorific gas, it is necessary to select the correct jet of the mixer.

In that case, refer to the manual [**Adjustment for Natural Gas Engine DG972**].

Japanese standard gas higher calorific value : 11000kcal/m³ (1236BTU/ft³)
 supply pressure : 0.98 – 2.45kPa (7.35 – 18.38mmHg)

Equipments Vacuum Meter : Not KUBOTA supplied
 Adjustable Jet : Service Tool

4. Application Check Item

The items as shown below must be managed for all engines, and these items must be informed to KUBOTA with Application Check results.

Refer to the attached sheet [**Application Check Sheet for DG972**].

- 1) The diameter of the jet (with the intake vacuum curve)
- 2) The calorific value of the gas
- 3) The supply pressure of gas
- 4) The serial number of the engine

5. Fuel diagram

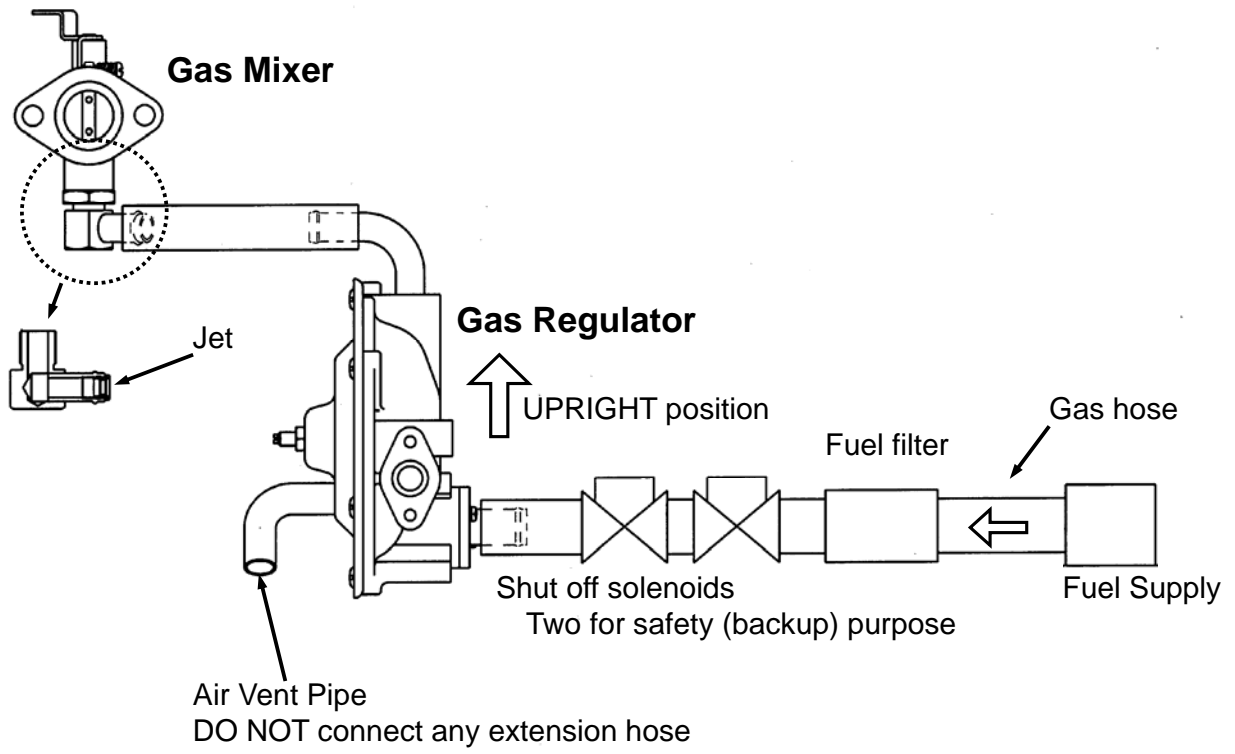

NATURAL GAS ENGINE

KUBOTA DG SERIES (3-cylinder)

DG972-E2

2
EPA Tier

RATED POWER

17.6kW@3600rpm



Photograph may show non-standard equipment.

PERFORMANCE CURVE

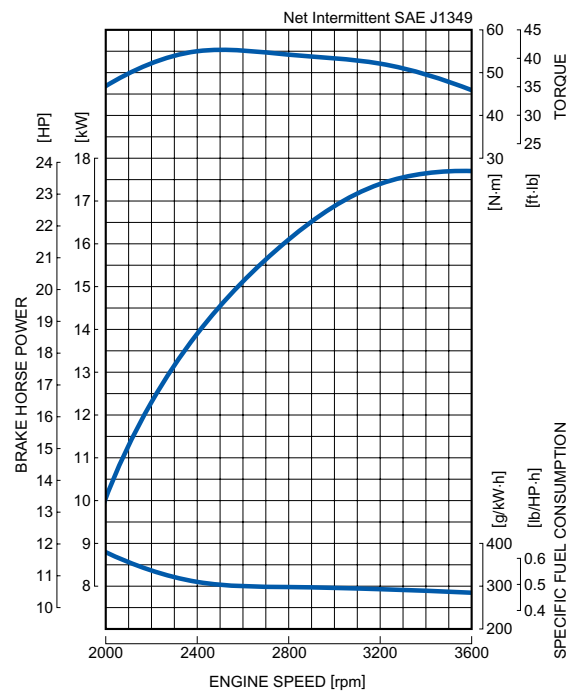

FEATURES and BENEFITS

New Engine Series

- The Kubota DG Series offers a new solution to the increasing needs for natural gas engine. The diesel engine based Kubota DG Series gives users the same foot-print, reliability and durability of D902, WG972, and DF972 acknowledged as the world's top quality small industrial engines.
- Kubota offers SAE Flywheel Housing and Rear End Plate specifications for the DG972 engine. These options offer users flexible Power Take Off (PTO) choices.
- The Kubota DG Series is designed to endure use outdoors under severe environment. This series is equipped with a bypass breather tube to avoid freezing below zero.

Emission

- Kubota DG Series complies with EPA Tier 2 Emissions Regulations. EPA regulation is one of the most stringent emissions regulations in the world.

Best Fuel System

- Specialized for Natural Gas use, the DG972 engine eliminated the carburetor, regulator and a fuel filter parts, which are only necessary for Gasoline or LPG use. Also, Kubota adopts the best jet set and the ignition timing that provides the best engine performance in severe conditions.

Ease maintenance cost and time

- Mechanical governor system will contribute to lower maintenance cost and prevents users from having to deal with complicated electric maintenance. Moreover, water resistant spark plug caps are adopted for outdoor use.

GENERAL SPECIFICATION

Model		DG972-E2
Emission Regulation		Tier 2
Type		Vertical 4-cycle Liquid Cooled Natural Gas
Number of Cylinders		3
Bore	mm (in)	74.5 (2.93)
Stroke	mm (in)	73.6 (2.9)
Displacement	L (cu.in)	0.962 (58.70)
Fuel		Natural Gas
Intake System		Naturally Aspirated
Maximum Speed	rpm	3600
Output: Net Intermittent	kW	17.6
	hp	23.6
	ps	23.9
Direction of Rotation		Counterclockwise Viewed on Flywheel
Oil Pan Capacity	L (gal)	3.7 (0.98)
Starter Capacity	V-kW	12-1.0
Alternator Capacity	V-A	12-40
Length	mm (in)	525.5 (20.69)* ¹ / 452.5 (17.81)* ²
Width	mm (in)	415.4 (16.35)
Height (1)	mm (in)	502.5 (19.78)
Height (2)	mm (in)	159.0 (6.26)
Dry Weight	kg (lb)	72.0 (158.7)* ¹ / 95.4 (210.3)* ²

*Specification is subject to change without notice.

*Output: Net Intermittent SAE J1349

*Dry weight is according to Kubota's standard specification.
When specification varies, the weight will vary accordingly.

*¹ with SAE Flywheel and Housing

*² with Rear End Plate

DIMENSIONS

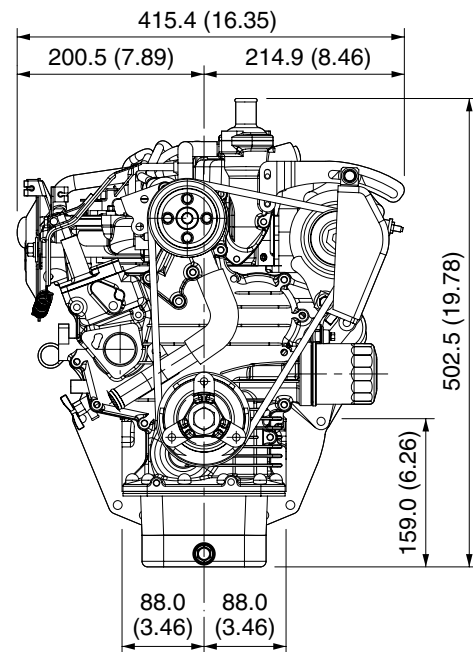
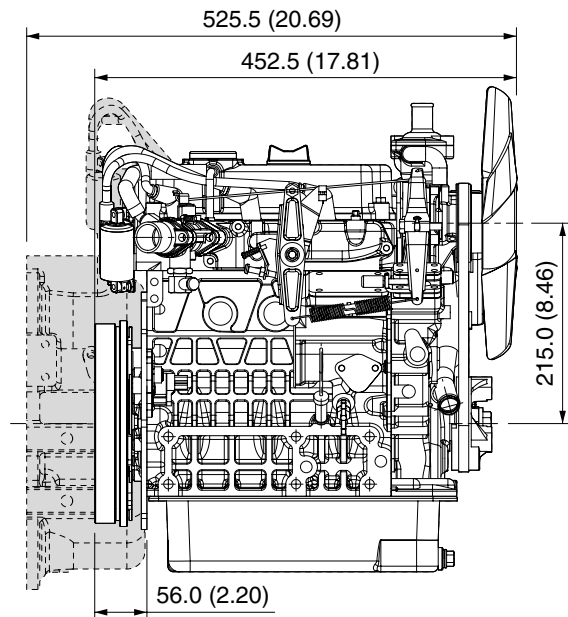

KUBOTA Corporation

2-47, Shikitsuhihigashi 1-chome, Naniwa-ku, Osaka, 556-8601 Japan
Fax: 06-6648-3521

<http://www.engine.kubota.co.jp>

Your Driving Force
KUBOTA ENGINE

Attachment O

Tanker Truck Loading Data Sheet

ATTACHMENT O – TANKER TRUCK LOADING DATA SHEET

Complete this data sheet for each new or modified bulk liquid transfer area or loading rack at the facility. This is to be used for bulk liquid transfer operations to tanker trucks. Use extra pages if necessary.

Truck Loadout Collection Efficiencies

The following applicable capture efficiencies of a truck loadout are allowed:

- For tanker trucks passing the MACT level annual leak test – 99.2%
- For tanker trucks passing the NSPS level annual leak test – 98.7%
- For tanker trucks not passing one of the annual leak tests listed above – 70%

Compliance with this requirement shall be demonstrated by keeping records of the applicable MACT or NSPS Annual Leak Test certification for *every* truck and railcar loaded/unloaded. This requirement can be satisfied if the trucking company provided certification that its entire fleet was compliant. This certification must be submitted in writing to the Director of the DAQ. These additional requirements must be noted in the Registration Application.

Emission Unit ID#: L001, L002	Emission Point ID#: EP-L001, EP-L002	Year Installed/Modified: 2013
-------------------------------	--------------------------------------	-------------------------------

Emission Unit Description: **Condensate Loading, Produced Water Loading**

Loading Area Data

Number of Pumps: 2	Number of Liquids Loaded: 2	Max number of trucks loading at one time: 2
--------------------	-----------------------------	---

Are Tanker trucks pressure tested for leaks at this any other location? Yes No Not Required

If Yes, Please Describe: Tank trucks are pressure tested for leaks at the location of the leak testing company. Trucks are tested using EPA Method 27-internal vapor valve test and issued certification that DOT requirements are met.

Provide description of closed vent system and any bypasses

Are any of the following truck loadout systems utilized? **No**

- Closed System to Tanker Truck passing a MACT level annual leak test?
- Closed System to Tanker Truck passing a NSPS level annual leak test?
- Closed System to Tanker Truck not passing an annual leak test and has vapor return?

Projected Maximum Operating Schedule (for rack or transfer point as a whole)

Time	Jan - Mar	Apr - Jun	Jul - Sept	Oct - Dec
Hours/day	5	5	5	5
Days/week	3	3	3	3

Bulk Liquid Data (use extra pages as necessary)

Liquid Name	Condensate	Produced Water	
Max. Daily Throughput (1000 gal/day)	25.54	20.58	
Max. Annual Throughput (1000 gal/yr)	9320.64	7511.70	
Loading Method	BF	BF	
Max. Fill Rate (gal/min)	168	168	
Average Fill Time (min/loading)	50	50	
Max. Bulk Liquid Temperature (F)	75.94	75.94	
True Vapor Pressure	3.34	0.49	
Cargo Vessel Condition	U	U	
Control Equipment or Method	None	None	
Max. Collection Efficiency (%)	0	0	
Max. Control Efficiency (%)	0	0	
Max VOC Emission Rate	Loading (lb/hr)	13.4718	0.0012
	Annual (ton/yr)	6.2285	0.0004
Max HAP Emission Rate	Loading (lb/hr)	0.0768	2.35E-06
	Annual (ton/yr)	0.0355	8.75E-07
Estimation Method	Promax	Promax	

- 1 BF Bottom Fill SP Splash Fill SUB Submerged Fill
- 2 At maximum bulk liquid temperature
- 3 B Ballasted Vessel C Cleaned U Uncleaned (dedicated servi O Other (describe)
- 4 List as many as apply (complete and submit appropriate Air Pollution Control Device Sheets)
- CA Carbon Adsorption VB Dedicated Vapor Balance (closed system)
- ECD Enclosed Combustion Device F Flare
- TO Thermal Oxidization or Incineration
- 5 EPA EPA Emission Factor in AP-42 MB Material Balance
- TM Test Measurement based upon test data submittal O Other (describe)

Attachment R
Air Pollution Control Device – Emission
Reduction Device Sheets

ATTACHMENT R – AIR POLLUTION CONTROL DEVICE / EMISSION REDUCTION DEVICE SHEETS

Complete the applicable air pollution control device sheet s for each flare, vapor combustor, thermal oxidizer, condenser, adsorption system, vapor recovery unit , BTEX Eliminator, Reboiler with and without Glow Plug, etc. at the facility. Use extra pages if necessary.

Emissions calculations must be performed using the most conservative control device efficiency.

The following five (5) rows are only to be completed if registering an alternative air pollution control device.

Emission Unit ID:	NA	Make/Model:	NA
Primary Control Device ID:	NA	Make/Model	NA
Control Efficiency (%):	NA	APCD/ERD Data Sheet Completed	<input type="checkbox"/> Yes <input type="checkbox"/> No
Secondary Control Device ID:	NA	Make/Model	NA
Control Efficiency (%):	NA	APCD/ERD Data Sheet Completed	<input type="checkbox"/> Yes <input type="checkbox"/> No

VAPOR COMBUSTION (Including Enclosed Combustors)

General Information

Control Device ID#:	EC001-003	Installation Date: <input checked="" type="checkbox"/> New <input type="checkbox"/> Modified <input type="checkbox"/> Relocated	
Maximum Rated Total Flow Capacity 5458 scfh 131000 scfd	Maximum Design Heating Input (from mfg. spec sheet) 12.0 MMBTU/hr	Design Heat Content 2300 BTU/scf	

Control Device Information

Type of Vapor Combustion Control?

- Enclosed Combustion Device Elevated Flare Ground Flare
 Thermal Oxidizer

Manufacturer: Cimarron	Hours of operation per year?	8760
Model: 48" HV ECD		

List the emission units whose emissions are controlled by this vapor control device (Emission Point ID# NA)

Emission Unit ID#	Emission Source Description	Emission Unit ID#	Emission Source Description
TANKCOND001-010	Condensate Tanks		
TANKPW001-002	Produced Water Tanks		

If this vapor combustor controls emissions from more than six (6) emission units, please attach additional pages.

Assist Type (Flares only) <input type="checkbox"/> Steam <input type="checkbox"/> Air <input type="checkbox"/> Pressure <input checked="" type="checkbox"/> Non	Flare height 25 feet	Tip Diameter 3.33 feet	Was the design per §60.18? <input checked="" type="checkbox"/> Yes <input type="checkbox"/> No Provide determination
---	-----------------------------	-------------------------------	--

Waste Gas Information

Maximum Waste Gas Flow Rate 65.79 (scfm)	Heat Value of Waste Gas Stream 2,563.79 BTU/ft ³	Exit Velocity of the Emission Stream 0.1259 (ft/s)
---	--	---

Please see Attachment S, Tables 6 & 7 for VOC composition/ characteristics of the waste gas stream to be burned.

Pilot Gas Information

Number of Pilot Lights 3	Fuel Flow Rate to Pilot Flame per Pilot 12.6 scfh	Heat Input per Pilot 12800 BTU/hr	Will automatic re-ignition be used? <input checked="" type="checkbox"/> Yes <input type="checkbox"/> No
---------------------------------	--	--	--

If automatic re-ignition is used, please describe the method. **Flame Rectification, a thermocouple equivalent**

Is pilot flame equipped with a monitor to detect the presence of the flame? <input checked="" type="checkbox"/> Yes <input type="checkbox"/> No	If Yes, What type? <input checked="" type="checkbox"/> Thermocouple <input type="checkbox"/> Infrared <input type="checkbox"/> Ultraviolet <input type="checkbox"/> Camera <input type="checkbox"/> Other:
--	--

Describe all operating ranges and maintenance procedures required by the manufacturer to maintain the warranty. *(If unavailable, please indicate).*

Additional information attached? <input checked="" type="checkbox"/> Yes <input type="checkbox"/> No	Manufacturer's specs sheet
Please attach copies of manufacturer's data sheets, drawings, flame demonstration per §60.18 or §63.11 (b) and performance testing.	

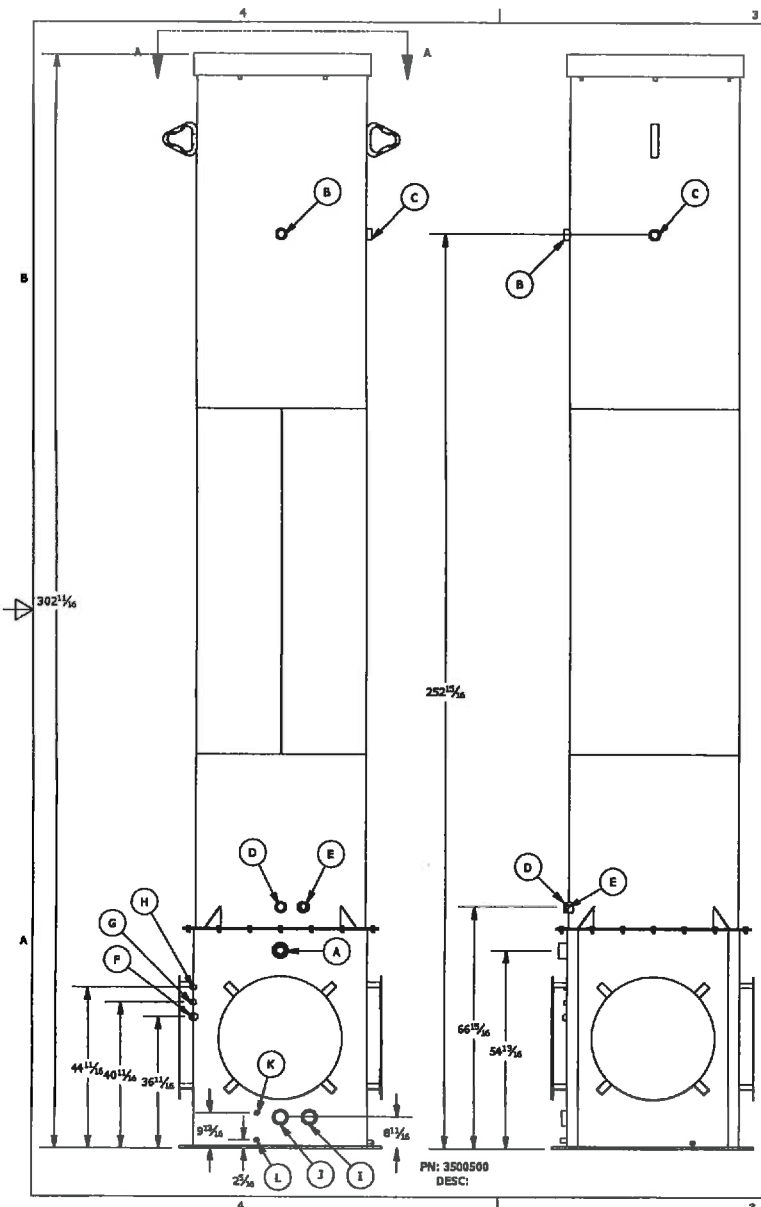

**48" DIA x 302 5/8" HEIGHT, 88 ORIFICES
EMISSION CONTROL DEVICE**

- * >98% TVOC DRE, CERTIFIED USEPA 40 CFR 60, APPENDIX A, SOURCE EMISSIONS TEST METHODS REFERENCED. MEETS ALL EPA & CDPHE REGULATIONS.
- * DESTROYS OIL/CONDENSATE PRODUCTION TANK VAPORS W/ NO VISIBLE FLAME.
- * EXCELLENT OPACITY AND SMOKELESS OPERATION.
- * RELIABLE AND CUSTOMIZABLE IGNITION.
- * VERY LOW CAPITAL AND OPERATING COST.
- * EASY TO OPERATE AND MAINTAIN.
- * FIELD TESTED TO DESTROY UP TO 119.5 MDSCFD (131 MCFD) @ 10 oz/in²; 2300 BTU/CF WASTE GAS (SG 1.45)
- * STRUCTURE CERTIFIED FOR 90 MPH 3-SEC WIND GUST PER ASCE 7-05 & IBC 2006 STANDARDS. HIGHER WIND LOAD RATED STRUCTURES AVAILABLE.

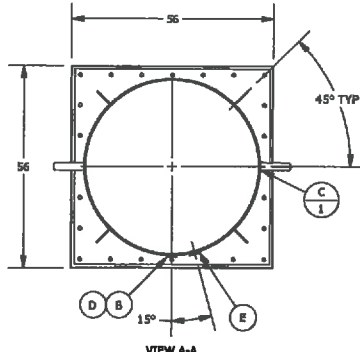

PN: 3500500
DESC:

SCHEDULE OF NOZZLES			
MARK	QTY	DESCRIPTION	SERVICE
A	1	3" HALF COUPLING	2000# BURNER WASTE GAS IN
B	1	2" FULL COUPLING	3000# FLOW TEST/AUTOMATION
C	1	2" FULL COUPLING	3000# FLOW TEST/AUTOMATION
D	1	2" FULL COUPLING	3000# SIGHT GLASS
E	1	2" FULL COUPLING	3000# MANUAL LIGHTING
F	1	1" FULL COUPLING	3000# PILOT GAS IN
G	1	1/2" FULL COUPLING	3000# IGNITOR CABLE
H	1	1/2" FULL COUPLING	3000# AUTOMATION
I	1	3" HALF COUPLING	3000# DRIP TANK WASTE GAS IN
J	1	3" HALF COUPLING	3000# DRIP TANK WASTE GAS OUT
K	1	1/2" FULL COUPLING	3000# AUTOMATION
L	1	1/2" FULL COUPLING	3000# LIQUID DRAIN

- UNLESS OTHERWISE SPECIFIED
1. REMOVE ALL BURRS AND SHARP CORNERS.
 2. COR. RAD .03
 3. DO NOT SCALE DRAWING.
 4. ALL DIMENSIONS ARE IN INCHES.
 5. MACHINE FIN.
 6. FABRICATION AND SHARP CORNERS.
 - .X = ± 0.25
 - .XX = ± 0.125
 - .XXX = ± 0.06
 - ANGLES ± 3°
 7. MACHINE
 - .X = ± 0.030
 - .XX = ± 0.015
 - .XXX = ± 0.005
 - ANGLES ± 1/2°
 - CONTRICTY WITHIN 0.010 TIR

APPROVED FOR A.S.M.E CODE, SECTION VIII DIV 1
ED, ADDENDA BY, DATE

CIMARRON
Energy Inc.

TITLE:
48" HIGH VOLLUME BCD

DATE: _____ WO No.: _____ SHEET: 1 OF 1

DRAWN BY: TDS | REV. | DRAW NO.: 3500500

Attachment S

Emissions Calculations

Table 1

**Facility Information
Vogt Well Pad
Doddridge County, West Virginia
Antero Resources Corporation**

Oil and Gas Site General Information

Administrative Information	
Company Name	Antero Resources Corporation
Facility/Well Name	Vogt Well Pad
Nearest City/Town	West union
SIC Code	1311
Latitude/Longitude	39.277572, -80.862125
County	Doddridge County

Technical Information	
Max Condensate Site Throughput (bbl/day):	608
Max Produced Water Site Throughput (bbl/day):	490
Are there any sour gas streams at this site?	No
Is this site currently operational/producing?	Yes

Equipment/Processes at Site	
Equipment/Process Types	How many for this site?
Fugitives	10
IC Engines	1
Gas Production Unit Heaters	10
Line Heaters	10
Condensate Tanks	10
Produced Water Tanks	2
Loading Jobs	2
Enclosed Combustors	3

Table 2

Uncontrolled/Controlled Emissions Summary
 Vogt Well Pad
 Doddridge County, West Virginia
 Antero Resources Corporation

Emission Source	VOC		NO _x		CO _{2e}		CO		SO ₂		PM _{2.5}		PM ₁₀		Lead		Total HAPs		Benzene		Xylenes		Formaldehyde	
	(lbs/hr)	(ton/yr)	(lbs/hr)	(ton/yr)	(lbs/hr)	(ton/yr)	(lbs/hr)	(ton/yr)	(lbs/hr)	(ton/yr)	(lbs/hr)	(ton/yr)	(lbs/hr)	(ton/yr)	(lbs/hr)	(ton/yr)	(lbs/hr)	(ton/yr)	(lbs/hr)	(ton/yr)	(lbs/hr)	(ton/yr)	(lbs/hr)	(ton/yr)
UNCONTROLLED (Fugitives, Storage Tanks, Engine, Gas Production Unit Heaters, Line Heaters)																								
Fugitive Emissions (Component Count, PCV and Hauling) ¹	3.7182	16.2858			93.287	408.60							3.3311	1.6653			0.3710	1.6250	0.0080	0.0348	6.57E-02	2.88E-01		
Flashing, Working and Breathing (F/W/B) Losses ²	368.1662	1612.5680			336.5270	1473.9882											28.8635	126.4220	0.2401	1.0515	0.3280	1.4366		
Engine Emissions ³	6.94E-03	3.04E-02	3.16E-01	1.38E+00	2.72E+01	1.19E+02	5.64E+00	2.47E+01	1.38E-04	6.04E-04	2.23E-03	9.76E-03	2.23E-03	9.76E-03			5.38E-03	2.36E-02	3.71E-04	1.62E-03	4.57E-05	2.00E-04	4.81E-03	2.11E-02
Gas Production Unit Heater Emissions ⁴	0.0677	0.2964	1.2306	5.3899	1,476.68	6,467.87	1.0337	4.5275	0.0074	0.0323	0.0935	0.4096	0.0935	0.4096	6.15E-06	2.69E-05	2.32E-02	1.01E-01	2.58E-05	1.13E-04			0.0009	0.0040
Line Heater Emissions ⁵	0.0902	0.3953	1.6408	7.1865	1,968.91	8,623.83	1.3782	6.0367	0.0098	0.0431	0.1247	0.5462	0.1247	0.5462	8.20E-06	3.59E-05	3.09E-02	1.35E-01	3.45E-05	1.51E-04			0.0012	0.0054
TOTALS:	372.0493	1629.5759	3.1871	13.9595	3902.5587	17093.2070	8.0564	35.2870	0.0174	0.0761	0.2204	0.9656	3.5516	2.6308	1.44E-05	6.29E-05	29.2939	128.3073	0.2485	1.0882	0.3937	1.7245	0.0070	0.0305
TOTALS (Excluding Fugitives):	368.3311	1613.2901	3.1871	13.9595	3809.2714	16684.6088	8.0564	35.2870	0.0174	0.0761	0.2204	0.9656	3.5516	2.6308	1.44E-05	6.29E-05	28.9229	126.6823	0.2405	1.0534	0.3280	1.4368	0.0070	0.0305

UNCONTROLLED (Truck Loading Emissions)

Truck Loading Emissions ⁵	13.4730	6.2289			3.1468	1.3795											0.0768	3.55E-02	0.0005	2.37E-04	0.0033	1.55E-03		
--------------------------------------	---------	--------	--	--	--------	--------	--	--	--	--	--	--	--	--	--	--	--------	----------	--------	----------	--------	----------	--	--

CONTROLLED EMISSIONS

Enclosed Combustor Emissions (from F/W/B losses) ⁶	7.3635	32.2523	0.3985	1.7456	1416.7980	6205.5753	0.3348	1.4663	2.27E-05	0.0001	0.0227	0.0995	0.0303	0.1327	1.99E-06	8.73E-06	0.5773	2.5287	0.0048	0.0210	0.0066	0.0287	2.84E-06	1.24E-05	
Controlled Fugitive Emissions from Hauling													1.6656	0.8326											
TOTALS:	7.36E+00	3.23E+01	3.99E-01	1.75E+00	1.42E+03	6.21E+03	3.35E-01	1.47E+00	2.27E-05	9.93E-05	2.27E-02	9.95E-02	1.70E+00	9.65E-01	1.99E-06	8.73E-06	5.77E-01	2.53E+00	4.80E-03	2.10E-02	6.56E-03	2.87E-02	2.84E-06	1.24E-05	

POTENTIAL TO EMIT⁷	11.2466	55.4891	3.5856	15.7051	4982.8297	21826.1736	8.3912	36.7533	0.0174	0.0762	0.2432	1.0651	1.9163	1.9309	1.63E-05	7.16E-05	1.0078	4.4496	0.0132	0.0580	0.0723	0.3182	0.0070	0.0305
POTENTIAL TO EMIT (Excluding Fugitives)	7.5284	32.9744	3.5856	15.7051	4889.5424	21416.1959	8.3912	36.7533	0.0174	0.0762	0.2432	1.0651	0.2507	1.0982	1.63E-05	7.16E-05	0.6368	2.7891	0.0052	0.0229	0.0066	0.0289	0.0070	0.0305

Enter any notes here:

- 1 - See Tables 4 and 5 for fugitive emission calculations; Table 12 for PM emissions from hauling.
- 2 - See Tables 6 and 7 for tanks emission calculations
- 3 - See Table 13 for engine emissions
- 4 - See Table 9 for gas production unit heater and line heater emission calculations
- 5 - The maximum emission was calculated based on tank truck capacity of 200 barrels and actual fill rate of 50 minutes per tank truck. At a production rate of 608 barrels per day, VOC emissions would be 13.473 pounds per hour when there are truck loading activities. Average hourly VOC emissions from truck loading is 1.4221 pound per hour.
- 6 - See Table 10 and 11 for enclosed combustion emission calculations.
- 7 - The hourly potential to emit is the sum of emissions from gas production unit heaters, line heaters, engine, storage tanks, enclosed combustors, and fugitives. Does not include emissions from loading (see footnote 5). The total TPY PTE is the sum of all emissions.
 PM 10 TPY is the sum of uncontrolled hauling and other PM10 sources.

Table 3

**Permits Summary
Vogt Well Pad
Doddridge County, West Virginia
Antero Resources Corporation**

Pollutant		Emissions		Threshold	Threshold Exceeded?	
		Uncontrolled	Controlled		Uncontrolled	Controlled
VOC	lbs/hr	372.0493	11.2466	6	Yes	
	tons/yr	1635.8048	55.4891	10	Yes	Yes
NO _x	lbs/hr	3.1871	3.5856	6		
	tons/yr	13.9595	15.7051	10	Yes	Yes
CO	lbs/hr	8.0564	8.3912	6	Yes	Yes
	tons/yr	35.2870	36.7533	10	Yes	Yes
SO ₂	lbs/hr	0.0174	0.0174	6		
	tons/yr	0.0761	0.0762	10		
PM _{2.5}	lbs/hr	0.2204	0.2432	6		
	tons/yr	0.9656	1.0651	10		
PM ₁₀	lbs/hr	3.5516	1.9163	6		
	tons/yr	2.6308	1.9309	10		
Lead	lbs/hr	1.44E-05	1.63E-05	6		
	tons/yr	6.29E-05	7.16E-05	10		
Total HAPs	lbs/hr	29.2939	1.0078	2	Yes	
	tons/yr	128.3429	4.4496	5	Yes	
Total TAPs	lbs/hr	0.2554	0.0202	1.14		
n-Hexane	lbs/hr	28.0943	0.8573			
	tons/yr	123.0855	3.7874			
Toluene	lbs/hr	0.3868	0.0322			
	tons/yr	1.6951	0.1419			
Ethylbenzene	lbs/hr	0.1635	0.0257			
	tons/yr	0.7169	0.1133			
Xylenes	lbs/hr	0.3937	0.0723			
	tons/yr	1.7261	0.3182			
Benzene	lbs/hr	0.2485	0.0132			
	tons/yr	1.0885	0.0580			

Enter any notes here:	<p>1. Emissions are based on 98% Enclosed Combustor DRE operating 100% of the time.</p> <p>2. Please see Attachment J - Fugitive Emissions Data Summary Sheet and Attachment T - Emission Points Summary Sheet for sitewide sources and breakdown of emission quantities.</p>
------------------------------	---

Table 4

Fugitive Emissions
 Vogt Well Pad
 Doddridge County, West Virginia
 Antero Resources Corporation

VOC Type:	Condensate VOC
Emission Type:	Steady State (continuous)

Gas Weight Fraction From Analysis:	VOC frac	0.165
	Benzene frac	0.000
	Toluene	0.000
	Ethylbenzene	0.000
	Xylenes	0.000
	n-Hexane	0.011
	HAPs	0.011
	Methane	0.625

Gas					
Number	Component	Pollutant	Emission Factor (kg/hr of THC per component)	kg/hr	lb/yr
500	Valves	Gas VOC	0.004500	0.37	7,172.98
		Non VOC	0.004500	1.88	36,189.02
		HAPs	0.004500	0.02	459.97
		CO2e	0.004500	35.15	677,446.85
590	Connectors	VOC	0.000200	0.02	376.18
		Non-VOC	0.000200	0.10	1,897.91
		HAPs	0.000200	0.00	24.12
		CO2e	0.000200	1.84	35,528.32
130	Flanges	VOC	0.000390	0.01	161.63
		Non-VOC	0.000390	0.04	815.46
		HAPs	0.000390	0.00	10.36
		CO2e	0.000390	0.792089	15265.135589
Total VOCs:				0.40	7710.80
Total THC:				2.42	46613.19

Light Liquid Weight Fraction From Analysis:	VOC frac	0.958
	Benzene frac	0.003
	Toluene	0.009
	Ethylbenzene	0.008
	Xylenes	0.023
	n-hexane	0.065
	HAPs	0.108
	Methane	0.014

Light Liquid					
Number	Component	Pollutant	Emission Factor (kg/hr of THC per component)	kg/hr	lb/yr
520	Valves	Light Liquid VOC	0.002500	1.25	24,013.13
		Light Liquid Non-VOC	0.002500	0.05	1,040.47
		Light Liquid HAPs	0.002500	0.14	2,701.19
		CO2e	0.002500	0.46	8888.24
Total VOC:				1.25	24,013.13
Total THC:				1.30	25,053.60

Fugitive Total Emissions			
	Annual Emissions (lb/yr)	Annual Emissions (lb/hr)	Annual Emissions (tpy)
VOC	31,723.93	3.62	15.86
Ethylbenzene		0.02	0.10
Toluene		0.02	0.11
Xylenes		0.07	0.29
n-Hexane		0.24	1.07
TAPs (Benzene)		0.01	0.03
HAPs		0.36	1.60
CO _{2e}	737,128.54	84.15	368.56

Enter Notes Here:	Fugitive emissions based on an estimated component count Global Warming Potentials from EPA site <u>Reference to Emission factors used:</u>
	1. Emission factors are for oil and gas production facilities (not refineries) come from the EPA's "Protocol for Equipment Leak Emission Estimates" November 1995, EPA 4531, R-95-017, Table 2-4. 2. Percent of speciated VOCs used in fugitive calculations are based on the total hydrocarbons, not of the total sample.

Table 5

**Pneumatic Control Valve Emissions
Vogt Well Pad
Doddridge County, West Virginia
Antero Resources Corporation**

Number of PCVs	40
Bleed Rate (scf/day/PCV)	6.6
Total Bleed Rate (scf/day)	264

Component	Mol%	Molecular Weight (lb/lb-mole)	Component Flow (scf/day)	Component Moles (lb-moles)	Component Emissions		
					(lbs/day)	(lbs/hr)	(tons/year)
H2S	0.00E+00	34.08	0.00E+00	0.00E+00	0.00E+00	0.00E+00	0.00E+00
Nitrogen	0.564	14.01	1.48896	3.92E-03	0.05	2.29E-03	0.01
Carbon Dioxide	0.1647	44.01	0.434808	1.15E-03	0.05	2.10E-03	9.20E-03
Methane	78.61509	16.04	207.5438376	0.55	8.77	0.37	1.60
Ethane	14.0689	30.07	37.141896	0.10	2.94	0.12	0.54
Propane	4.2164	44.1	11.131296	0.03	1.29	0.05	0.24
Isobutane	0.5041	58.12	1.330824	3.51E-03	0.20	0.01	0.04
n-Butane	1.0298	58.12	2.718672	7.16E-03	0.42	0.02	0.08
Isopentane	0.2618	72.15	0.691152	1.82E-03	0.13	5.48E-03	0.02
n-Pentane	0.2553	72.15	0.673992	1.78E-03	0.13	5.34E-03	0.02
2-Methylpentane	0.00E+00	86.18	0.00E+00	0.00E+00	0.00E+00	0.00E+00	0.00E+00
3-Methylpentane	0.00E+00	86.18	0.00E+00	0.00E+00	0.00E+00	0.00E+00	0.00E+00
n-Hexane	0.2484	86.18	0.655776	1.73E-03	0.15	0.01	0.03
Methylcyclopentane	0.00E+00	84.16	0.00E+00	0.00E+00	0.00E+00	0.00E+00	0.00E+00
Benzene	0.00E+00	78.11	0.00E+00	0.00E+00	0.00E+00	0.00E+00	0.00E+00
2-Methylhexane	0.00E+00	100.2	0.00E+00	0.00E+00	0.00E+00	0.00E+00	0.00E+00
3-Methylhexane	0.00E+00	100.2	0.00E+00	0.00E+00	0.00E+00	0.00E+00	0.00E+00
Heptane	0.00E+00	100.21	0.00E+00	0.00E+00	0.00E+00	0.00E+00	0.00E+00
Methylcyclohexane	0.00E+00	98.186	0.00E+00	0.00E+00	0.00E+00	0.00E+00	0.00E+00
Toluene	0.00E+00	92.14	0.00E+00	0.00E+00	0.00E+00	0.00E+00	0.00E+00
Octane	0.00E+00	114.23	0.00E+00	0.00E+00	0.00E+00	0.00E+00	0.00E+00
Ethylbenzene	0.00E+00	106.17	0.00E+00	0.00E+00	0.00E+00	0.00E+00	0.00E+00
m & p-Xylene	0.00E+00	106.16	0.00E+00	0.00E+00	0.00E+00	0.00E+00	0.00E+00
o-Xylene	0.00E+00	106.16	0.00E+00	0.00E+00	0.00E+00	0.00E+00	0.00E+00
Nonane	0.00E+00	128.2	0.00E+00	0.00E+00	0.00E+00	0.00E+00	0.00E+00
C10+	0.00E+00	174.28	0.00E+00	0.00E+00	0.00E+00	0.00E+00	0.00E+00

	lb/hr	tpy
VOC Emissions	0.0968	0.4238
Benzene Emissions	0.00E+00	0.00E+00
Toluene Emissions	0.00E+00	0.00E+00
Ethylbenzene Emissions	0.00E+00	0.00E+00
Xylene Emissions	0.00E+00	0.00E+00
n-Hexane Emissions	0.0062	0.0272
HAPs Emissions	0.0062	0.0272
TAPs Emissions	0.00E+00	0.00E+00
CO _{2e} emissions	9.1402	40.0339

Enter any notes here:	1. PCV bleed rate obtained from the user manual for PCV http://issuu.com/rmcprocesscontrols/docs/mizer-pilot-operation--parts---installation-manual 2. Emissions per hour= Mol % x no. of PCV x bleed rate x MW / 379.48 / 24
------------------------------	---

Table 6

Uncontrolled Flashing Emissions
Vogt Well Pad
Doddridge County, West Virginia
Antero Resources Corporation

# Hours Operational	8760
---------------------	------

	Condensate Tank Flashing Losses			Produced Water Tank Flashing Losses		
	Vapor Mass Fraction wt%	Flashing Losses lbs/hr	Flashing Losses tpy	Vapor Mass Fraction wt%	Flashing Losses lbs/hr	Flashing Losses tpy
Water	0.0453	0.1982	0.8680	2.6814	0.1090	0.4774
H2S	0.0000	0.0000	0.0000	0.0000	0.0000	0.0000
Nitrogen	0.0035	0.0154	0.0673	0.3990	0.0162	0.0711
Carbon Dioxide	0.1151	0.5033	2.2046	3.5890	0.1459	0.6391
Methane	2.4935	10.9004	47.7437	59.5446	2.4207	10.6025
Ethane	17.0070	74.3473	325.6410	20.5811	0.8367	3.6647
Propane	29.8514	130.4976	571.5797	9.2884	0.3776	1.6539
Isobutane	8.0015	34.9791	153.2086	0.4733	0.0192	0.0843
n-Butane	18.6195	81.3964	356.5161	2.0150	0.0819	0.3588
Isopentane	6.6757	29.1832	127.8223	0.3974	0.0162	0.0708
n-Pentane	6.7384	29.4576	129.0245	0.3787	0.0154	0.0674
2-Methylpentane	0.5795	2.5332	11.0956	0.0141	0.0006	0.0025
3-Methylpentane	0.4018	1.7563	7.6927	0.0263	0.0011	0.0047
n-Hexane	6.3370	27.7025	121.3368	0.1213	0.0049	0.0216
Methylcyclopentane	0.1946	0.8508	3.7264	0.0380	0.0015	0.0068
Benzene	0.0540	0.2360	1.0338	0.0843	0.0034	0.0150
2-Methylhexane	0.4327	1.8918	8.2861	0.0092	0.0004	0.0016
3-Methylhexane	0.3475	1.5193	6.6545	0.0077	0.0003	0.0014
Heptane	0.6432	2.8119	12.3160	0.0150	0.0006	0.0027
Methylcyclohexane	0.4156	1.8170	7.9582	0.0526	0.0021	0.0094
Toluene	0.0812	0.3550	1.5551	0.1177	0.0048	0.0210
Octane	0.6780	2.9640	12.9822	0.0093	0.0004	0.0017
Ethylbenzene	0.0314	0.1374	0.6016	0.0445	0.0018	0.0079
m & p-Xylene	0.0359	0.1569	0.6873	0.0504	0.0021	0.0090
o-Xylene	0.0372	0.1627	0.7126	0.0548	0.0022	0.0098
Nonane	0.1534	0.6705	2.9366	0.0032	0.0001	0.0006
C10+	0.0260	0.1138	0.4985	0.0035	0.0001	0.0006
Total VOCs	80.336	351.19	1,538.2	13.205	0.5368	2.3512
Total CO _{2e}		273.01	1,195.8		60.66	265.7
Total TAPs (Benzene)		0.2360	1.0338		0.0034	0.0150
Toluene		0.3550	1.5551		0.0048	0.0210
Ethylbenzene		0.1374	0.6016		0.0018	0.0079
Xylenes		0.3196	1.4000		0.0043	0.0187
n-Hexane		27.702	121.337		0.0049	0.0216
Total HAPs		28.751	125.927		0.0192	0.0842
Total	100.00	437.16	1,914.7	100.00	4.065	17.81

Enter any notes here:	Vapor mass fractions and Flashing losses from Promax output
-----------------------	---

Table 7

Uncontrolled Working and Breathing Losses
Vogt Well Pad
Doddridge County, West Virginia
Antero Resources Corporation

Condensate Tank Information	
Number of Tanks	10
Maximum Working Losses (lbs/hr)	9.1221
Maximum Breathing Losses (lbs/hr)	12.2400
# Hours Operational	8760

	Condensate Tank W/B Losses						
	Vapor Mass Fraction wt%	Working Losses		Breathing Losses		Max W/B Losses	
		lbs/hr	tpy	lbs/hr	tpy	lbs/hr	tpy
H2S	0.00E+00	0.00E+00	0.00E+00	0.00E+00	0.00E+00	0.00E+00	0.00E+00
Nitrogen	0.0001	1.04E-05	4.54E-05	0.0000	0.0001	0.0000	0.0001
Carbon Dioxide	0.1190	0.0109	0.0475	0.0146	0.0638	0.0254	0.1113
Methane	0.5222	0.0476	0.2086	0.0639	0.2799	0.1115	0.4886
Ethane	22.4172	2.0449	8.9567	2.7439	12.0182	4.7888	20.9749
Propane	33.2118	3.0296	13.2697	4.0651	17.8053	7.0948	31.0751
Isobutane	8.2874	0.7560	3.3112	1.0144	4.4430	1.7704	7.7542
n-Butane	19.1746	1.7491	7.6612	2.3470	10.2798	4.0961	17.9410
Isopentane	6.4515	0.5885	2.5777	0.7897	3.4588	1.3782	6.0365
n-Pentane	6.4350	0.5870	2.5711	0.7876	3.4499	1.3747	6.0210
2-Methylpentane	0.5392	0.0492	0.2154	0.0660	0.2891	0.1152	0.5045
3-Methylpentane	0.3736	0.0341	0.1493	0.0457	0.2003	0.0798	0.3495
n-Hexane	0.4004	0.0365	0.1600	0.0490	0.2147	0.0855	0.3746
Methylcyclopentane	0.1696	0.0155	0.0678	0.0208	0.0909	0.0362	0.1587
Benzene	0.0029	2.67E-04	0.0012	0.0004	0.0016	0.0006	0.0027
2-Methylhexane	0.0257	2.35E-03	0.0103	0.0031	0.0138	0.0055	0.0241
3-Methylhexane	0.3116	0.0284	0.1245	0.0381	0.1671	0.0666	0.2916
Heptane	0.5314	0.0485	0.2123	0.0650	0.2849	0.1135	0.4972
Methylcyclohexane	0.3504	0.0320	0.1400	0.0429	0.1879	0.0749	0.3279
Toluene	0.0095	8.62E-04	3.78E-03	0.0012	0.0051	0.0020	0.0088
Octane	0.5198	0.0474	0.2077	0.0636	0.2787	0.1110	0.4863
Ethylbenzene	0.0068	6.23E-04	2.73E-03	0.0008	0.0037	0.0015	0.0064
m & p-Xylene	0.0100	9.17E-04	4.02E-03	0.0012	0.0054	0.0021	0.0094
o-Xylene	0.0090	8.25E-04	0.0036	0.0011	0.0048	0.0019	0.0085
Nonane	0.1067	0.0097	0.0426	0.0131	0.0572	0.0228	0.0998
C10+	0.0145	1.32E-03	0.0058	0.0018	0.0078	0.0031	0.0135
Total VOCs	76.942	7.0187	30.742	9.4177	41.2494	16.4364	71.991
Total CO _{2e}		1.2017	5.2633	1.6124	7.0623	2.8141	12.326
Total TAPs (Benzene)		2.67E-04	1.17E-03	0.0004	0.0016	0.0006	0.0027
Toluene		8.62E-04	3.78E-03	0.0012	0.0051	0.0020	0.0088
Ethylbenzene		6.23E-04	2.73E-03	0.0008	0.0037	0.0015	0.0064
Xylenes		1.74E-03	0.0076	0.0023	0.0102	0.0041	0.0179
n-Hexane		0.0365	0.1600	0.0490	0.2147	0.0855	0.3746
Total HAPs		0.0400	0.1753	0.0537	0.2352	0.0937	0.4105
Total	100.00	9.1221	39.9548	12.2400	53.6114	21.3622	93.566

Table 7

Uncontrolled Working and Breathing Losses
Vogt Well Pad
Doddridge County, West Virginia
Antero Resources Corporation

Produced Water Tank Information	
Number of Tanks	2
Maximum Working Losses (lbs/hr)	0.0358
Maximum Breathing Losses (lbs/hr)	0.0084

	Produced Water Tank W/B Losses						
	Vapor Mass Fraction wt%	Working Losses		Breathing Losses		Max W/B Losses	
		lbs/hr	tpy	lbs/hr	tpy	lbs/hr	tpy
H2S	0.00E+00	0.00E+00	0.00E+00	0.00E+00	0.00E+00	0.00E+00	0.00E+00
Nitrogen	0.0077	2.76E-06	1.21E-05	6.46E-07	2.83E-06	3.41E-06	1.49E-05
Carbon Dioxide	4.6781	0.0017	0.0073	0.0004	0.0017	0.0021	0.0090
Methane	3.2011	0.0011	0.0050	0.0003	0.0012	0.0014	0.0062
Ethane	1.0211	0.0004	0.0016	0.0001	0.0004	0.0005	0.0020
Propane	0.1123	4.02E-05	0.0002	9.40E-06	4.12E-05	4.96E-05	0.0002
Isobutane	0.0007	2.56E-07	1.12E-06	6.00E-08	2.63E-07	3.16E-07	1.38E-06
n-Butane	0.0046	1.64E-06	7.19E-06	3.84E-07	1.68E-06	2.03E-06	8.87E-06
Isopentane	0.0002	8.11E-08	3.55E-07	1.90E-08	8.32E-08	1.00E-07	4.39E-07
n-Pentane	0.0002	5.64E-08	2.47E-07	1.32E-08	5.78E-08	6.96E-08	3.05E-07
2-Methylpentane	1.12E-06	4.02E-10	1.76E-09	9.41E-11	4.12E-10	4.96E-10	2.17E-09
3-Methylpentane	5.07E-06	1.81E-09	7.93E-09	4.24E-10	1.86E-09	2.24E-09	9.79E-09
n-Hexane	3.74E-07	1.34E-10	5.85E-10	3.13E-11	1.37E-10	1.65E-10	7.22E-10
Methylcyclopentane	1.58E-05	5.64E-09	2.47E-08	1.32E-09	5.78E-09	6.96E-09	3.05E-08
Benzene	1.07E-04	3.84E-08	1.68E-07	8.98E-09	3.94E-08	4.74E-08	2.07E-07
2-Methylhexane	1.20E-08	4.28E-12	1.87E-11	1.00E-12	4.38E-12	5.28E-12	2.31E-11
3-Methylhexane	1.50E-07	5.38E-11	2.36E-10	1.26E-11	5.52E-11	6.64E-11	2.91E-10
Heptane	2.14E-07	7.66E-11	3.36E-10	1.79E-11	7.86E-11	9.46E-11	4.14E-10
Methylcyclohexane	4.66E-06	1.66E-09	7.29E-09	3.90E-10	1.71E-09	2.05E-09	9.00E-09
Toluene	7.22E-05	2.58E-08	1.13E-07	6.04E-09	2.65E-08	3.18E-08	1.39E-07
Octane	2.61E-08	9.33E-12	4.09E-11	2.18E-12	9.56E-12	1.15E-11	5.04E-11
Ethylbenzene	1.54E-05	5.49E-09	2.40E-08	1.28E-09	5.63E-09	6.77E-09	2.97E-08
m & p-Xylene	1.94E-05	6.94E-09	3.04E-08	1.63E-09	7.12E-09	8.57E-09	3.75E-08
o-Xylene	2.21E-05	7.89E-09	3.45E-08	1.85E-09	8.09E-09	9.73E-09	4.26E-08
Nonane	4.23E-09	1.51E-12	6.63E-12	3.54E-13	1.55E-12	1.87E-12	8.18E-12
C10+	1.42E-09	5.08E-13	2.22E-12	1.19E-13	5.20E-13	6.26E-13	2.74E-12
Total VOCs	0.1183	4.23E-05	0.0002	9.90E-06	4.34E-05	5.22E-05	0.0002
Total CO _{2e}		0.0303	0.1326	0.0071	0.0311	0.0374	0.1637
Total TAPs (Benzene)		3.84E-08	1.68E-07	8.98E-09	3.94E-08	4.74E-08	2.07E-07
Toluene		2.58E-08	1.13E-07	6.04E-09	2.65E-08	3.18E-08	1.39E-07
Ethylbenzene		5.49E-09	2.40E-08	1.28E-09	5.63E-09	6.77E-09	2.97E-08
Xylenes		1.48E-08	6.50E-08	3.47E-09	1.52E-08	1.83E-08	8.02E-08
n-Hexane		1.34E-10	5.85E-10	3.13E-11	1.37E-10	1.65E-10	7.22E-10
Total HAPs		8.46E-08	3.71E-07	1.98E-08	8.68E-08	1.04E-07	4.57E-07
Total	100.00	0.0358	0.1566	0.0084	0.0367	0.0441	0.1933

Enter any notes here:	Vapor mass fractions, working losses and breathing losses from Promax output
------------------------------	--

Table 8

Loading Emissions
Vogt Well Pad
Doddridge County, West Virginia
Antero Resources Corporation

Annual Loading	Oil Truck Loading	Water Truck Loading
RVP	4.45	1.0236
Annual Average Temp (F)	65.08	65.08
S (saturation factor)	0.6	0.6
P (true vapor pressure)	2.71	0.37
M (MW of vapor)	45.04	18.54
Collection Efficiency (%)	0.00	0.00
Loading Loss (lb/10 ³ gal)*	1.74	0.10
Maximum Throughput (gallons/hr)**	10,080	10,080
Average Throughput (gallons/yr)	9,320,640	7,511,700
Loading Emissions (lbs/hr)	17.51	0.99
Loading Emissions (tpy)	8.10	0.37

	Condensate Tank Loading Losses			Produced Water Tank Loading Losses		
	Vapor Mass Fraction wt%	Loading Losses lbs/hr	Loading Losses tpy	Vapor Mass Fraction wt%	Loading Losses lbs/hr	Loading Losses tpy
H2S	0.0000	0.00E+00	0.00E+00	0.00E+00	0.00E+00	0.00E+00
Nitrogen	0.0001	1.99E-05	9.19E-06	0.0077	7.66E-05	2.85E-05
Carbon Dioxide	0.1190	0.0208	9.63E-03	4.6781	4.64E-02	1.73E-02
Methane	0.5222	0.0914	4.23E-02	3.2011	3.18E-02	1.18E-02
Ethane	22.4172	3.9251	1.8147	1.0211	1.01E-02	3.77E-03
Propane	33.2118	5.8151	2.69E+00	0.1123	1.11E-03	4.15E-04
Isobutane	8.2874	1.4511	6.71E-01	0.0007	7.11E-06	2.65E-06
n-Butane	19.1746	3.3573	1.55E+00	0.0046	4.56E-05	1.70E-05
Isopentane	6.4515	1.1296	5.22E-01	0.0002	2.25E-06	8.39E-07
n-Pentane	6.4350	1.1267	5.21E-01	0.0002	1.56E-06	5.83E-07
2-Methylpentane	0.5392	0.0944	4.36E-02	1.12E-06	1.12E-08	4.15E-09
3-Methylpentane	0.3736	0.0654	3.02E-02	5.07E-06	5.03E-08	1.87E-08
n-Hexane	0.4004	0.0701	3.24E-02	3.74E-07	3.71E-09	1.38E-09
Methylcyclopentane	0.1696	0.0297	1.37E-02	1.58E-05	1.56E-07	5.83E-08
Benzene	0.0029	0.0005	2.37E-04	0.0001	1.06E-06	3.97E-07
2-Methylhexane	0.0257	0.0045	2.08E-03	1.20E-08	1.19E-10	4.42E-11
3-Methylhexane	0.3116	0.0546	2.52E-02	1.50E-07	1.49E-09	5.56E-10
Heptane	0.5314	0.0930	4.30E-02	2.14E-07	2.13E-09	7.92E-10
Methylcyclohexane	0.3504	0.0614	2.84E-02	4.66E-06	4.62E-08	1.72E-08
Toluene	0.0095	0.0017	7.65E-04	0.0001	7.16E-07	2.67E-07
Octane	0.5198	0.0910	4.21E-02	2.61E-08	2.59E-10	9.64E-11
Ethylbenzene	0.0068	0.0012	5.53E-04	1.54E-05	1.52E-07	5.67E-08
m & p-Xylene	0.0100	0.0018	8.13E-04	1.94E-05	1.93E-07	7.18E-08
o-Xylene	0.0090	0.0016	7.32E-04	2.21E-05	2.19E-07	8.15E-08
Nonane	0.1067	0.0187	8.64E-03	4.23E-09	4.20E-11	1.56E-11
C10+	0.0145	0.0025	1.17E-03	1.42E-09	1.41E-11	5.25E-12
Total VOCs	76.9415	13.4718	6.2285	0.1183	1.17E-03	4.37E-04
Total CO _{2e}		2.3065	1.0664		0.8402	0.3131
Total TAPs (Benzene)		0.0005	2.37E-04		1.06E-06	3.97E-07
Toluene		0.0017	7.65E-04		7.16E-07	2.67E-07
Ethylbenzene		0.0012	5.53E-04		1.52E-07	5.67E-08
Xylenes		0.0033	1.55E-03		4.11E-07	1.53E-07
n-Hexane		0.0701	3.24E-02		3.71E-09	1.38E-09
Total HAPs		0.0768	3.55E-02		2.35E-06	8.75E-07
Total	100.0000	17.5092	8.0951	100.0000	0.9920	0.3696

Enter any notes here

Vapor mass fractions and loading losses from Promax output

*Using equation $L_L = 12.46 * SPM/T$ from AP-42, Chapter 5, Section 5.2-4

MW was obtained by Promax; RVP was taken from laboratory reports

Annual Average Temp (F) obtained from Charleston, WV (preset in Promax)

S (saturation factor) is based on submerged loading, dedicated service as it was most representative

True vapor pressure (TVP) equation from AP-42, Chapter 7, Figure 7.1-13b

** Maximum throughput in gallons per hour obtained from actual transfer rate of 200 barrels in 50 minutes. (10,080 gal/hr = 200 bbl / 50 min x 42 gal/bbl x 60 min/hr)

Loading emissions are vented to the atmosphere.

Table 9

**Gas Production Unit Heater and Line Heater Emissions
Vogt Well Pad
Doddridge County, West Virginia
Antero Resources Corporation**

Gas Production Unit Heater Emissions

Number of Units	10
GPU Heater Rating (MMBtu/hr)	1.50
Operating hours/year	8760
Fuel Heat Value (Btu/scf)	1,219

Line Heater Emissions

Number of Units	10
Line Heater Rating (MMBtu/hr)	2.00
Operating hours/year	8760
Fuel Heat Value (Btu/scf)	1,219

Pollutant	Emission Factors (lb/MMscf)	lb/hr	tpy
NOx	100	1.231	5.390
CO	84	1.034	4.528
CO ₂	120,000	1476.683	6467.872
Lead	0.0005	6.15E-06	2.69E-05
N ₂ O	2.2	0.027	0.119
PM (Total)	7.6	0.094	0.410
SO ₂	0.6	0.007	0.032
TOC	11	0.135	0.593
Methane	2.3	0.028	0.124
VOC	5.5	0.068	0.296
HAPS			
2-Methylnaphthalene	2.40E-05	2.95E-07	1.29E-06
Benzene	2.10E-03	2.58E-05	1.13E-04
Dichlorobenzene	1.20E-03	1.48E-05	6.47E-05
Fluoranthene	3.00E-06	3.69E-08	1.62E-07
Fluorene	2.80E-06	3.45E-08	1.51E-07
Formaldehyde	7.50E-02	9.23E-04	4.04E-03
Hexane	1.80E+00	2.22E-02	9.70E-02
Naphthalene	6.10E-04	7.51E-06	3.29E-05
Phenanathrene	1.70E-05	2.09E-07	9.16E-07
Toluene	3.40E-03	4.18E-05	1.83E-04

Pollutant	Emission Factors (lb/MMscf)	lb/hr	tpy
NOx	100	1.641	7.187
CO	84	1.378	6.037
CO ₂	120,000	1968.911	8623.830
Lead	0.0005	8.20E-06	3.59E-05
N ₂ O	2.2	0.036	0.158
PM (Total)	7.6	0.125	0.546
SO ₂	0.6	0.010	0.043
TOC	11	0.180	0.791
Methane	2.3	0.038	0.165
VOC	5.5	0.090	0.395
HAPS			
2-Methylnaphthalene	2.40E-05	3.94E-07	1.72E-06
Benzene	2.10E-03	3.45E-05	1.51E-04
Dichlorobenzene	1.20E-03	1.97E-05	8.62E-05
Fluoranthene	3.00E-06	4.92E-08	2.16E-07
Fluorene	2.80E-06	4.59E-08	2.01E-07
Formaldehyde	7.50E-02	1.23E-03	5.39E-03
Hexane	1.80E+00	2.95E-02	1.29E-01
Naphthalene	6.10E-04	1.00E-05	4.38E-05
Phenanathrene	1.70E-05	2.79E-07	1.22E-06
Toluene	3.40E-03	5.58E-05	2.44E-04

	lb/hr	tpy
TOTAL Uncontrolled VOC	0.158	0.692
TOTAL Uncontrolled HAPS	0.054	0.237
TOTAL Uncontrolled TAPs (Benzene)	6.03E-05	2.64E-04
TOTAL Uncontrolled Toluene	9.76E-05	4.28E-04
TOTAL Uncontrolled Hexane	5.17E-02	2.26E-01
TOTAL Uncontrolled TAPs (Formaldehyde)	2.15E-03	9.43E-03
TOTAL CO _{2e} Emissions	3,466.07	15,181.38

Enter any notes here:

All Emission Factors based off AP-42 Sec 1.4 Natural Gas Combustion

Table 10

**Enclosed Combustor Emissions
Vogt Well Pad
Doddridge County, West Virginia
Antero Resources Corporation**

General Information	
Unit Name:	EC001, EC002, EC003

Pollutant	Emission Factor (lb/MMscf)
NOx	100
CO	84
PM10	7.6
PM2.5	5.7
SO ₂	0.6
CO ₂	120,000
VOC	5.5
benzene	2.10E-03
Hexane	1.80E+00
Toluene	3.40E-03
Formaldehyde	7.50E-02
N ₂ O	2.20
Lead	5.00E-04

Constants	
Btu/MMBtu	1,000,000
scf/MMscf	1,000,000
lb/ton	2,000
H ₂ S molecular weight	34.08
SO ₂ molecular weight	64.06
seconds/hour	3,600
inches/ft	12

Destruction Efficiency	
VOC percent destruction efficiency (%)	98
H ₂ S percent destruction efficiency (%)	98

Enclosed Combustor operating hours	8760
No. of Enclosed Combustors	3

Stream Information							
	1	2	3	4	5	6	Total
Stream Sent to Enclosed/Vapor Combustor (Enter Name of Each Stream Here)	pilot(s)	added fuel stream(s)	Oil Tank Flash Emissions	Water Tank Flash Emissions	Oil Tank W/B Emissions	Water Tank W/B Emissions	-
Maximum Expected Hourly Volumetric Flow Rate of Stream (scf/hr)	37.8	--	3,683.51	83.19	180.00	0.90	3,985.40
Maximum Expected Annual Volumetric Flow Rate of Stream (scf/yr)	331,128.00	--	32,267,508.04	728,748.09	1,576,785.01	7,909.23	34,912,078.36
Heating Content (Btu/ft ³)	1,219		2,622.45	1,163.20	2,561.32	96.88	2,563.79

Mass Flow Rates of the Vapors Sent to this Control Device, Hourly Basis (lb/hr)							
	1	2	3	4	5	6	Total
Stream Sent to Enclosed Combustor/Vapor Combustor	pilot(s)	added fuel stream(s)	Oil Tank Flash Emissions	Water Tank Flash Emissions	Oil Tank W/B Emissions	Water Tank W/B Emissions	-
H ₂ S	-	-	0.000	0.000	0.000	0.000	0.000
Total VOC	-	-	351.193	0.537	16.436	0.000	368.17
Benzene	-	-	0.236	0.003	0.001	0.000	0.240
Toluene	-	-	0.355	0.005	0.002	0.000	0.362
Ethylbenzene	-	-	0.137	0.002	0.001	0.000	0.141
Xylenes	-	-	0.320	0.004	0.004	0.000	0.328
n-Hexane	-	-	27.702	0.005	0.086	0.000	27.793
HAPs	-	-	28.751	0.019	0.094	0.000	28.863
Total Mass Flow	-	-	437.158	4.065	21.362	0.044	462.629

Mass Flow Rates of the Vapors Sent to this Control Device, Annual Basis (tpy)							
	1	2	3	4	5	6	Total
H ₂ S	-	-	0.000	0.000	0.000	0.000	0.000
Total VOC	-	-	1538.225	2.351	71.991	0.000	1612.568
Benzene	-	-	1.034	0.015	0.003	0.000	1.052
Toluene	-	-	1.555	0.021	0.009	0.000	1.585
Ethylbenzene	-	-	0.602	0.008	0.006	0.000	0.616
Xylenes	-	-	1.400	0.019	0.018	0.000	1.437
n-Hexane	-	-	121.337	0.022	0.375	0.000	121.733
HAP	-	-	125.927	0.084	0.410	0.000	126.422
Total Mass Flow	-	-	1914.750	17.806	93.566	0.193	2026.315

Table 10

**Enclosed Combustor Emissions
Vogt Well Pad
Doddridge County, West Virginia
Antero Resources Corporation**

Controlled Emissions							
Hourly (lb/hr)							
	1	2	3	4	5	6	Total
Stream Sent to Enclosed Combustor/Vapor Combustor	pilot(s)	added fuel stream(s)	Oil Tank Flash Emissions	Water Tank Flash Emissions	Oil Tank W/B Emissions	Water Tank W/B Emissions	-
NOx	0.004	-	0.368	0.008	0.018	0.000	0.40
CO	0.003	-	0.309	0.007	0.015	0.000	0.33
PM2.5	0.000	-	0.021	0.000	0.001	0.000	0.02
PM10	0.000	-	0.028	0.001	0.001	0.000	0.03
H2S	0.000	-	0.000	0.000	0.000	0.000	0.00
SO ₂	0.000	-	0.000	0.000	0.000	0.000	0.00
CO ₂	4.536	-	-	-	-	-	4.54
Total VOC	0.000	-	7.024	0.011	0.329	0.000	7.36
Benzene	0.000	-	0.005	0.000	0.000	0.000	0.00
Toluene	0.000	-	0.007	0.000	0.000	0.000	0.01
Ethylbenzene	0.000	-	0.003	0.000	0.000	0.000	0.00
Xylenes	0.000	-	0.006	0.000	0.000	0.000	0.01
n-Hexane	0.000	-	0.554	0.000	0.002	0.000	0.56
HAP	0.000	-	0.575	0.000	0.002	0.000	0.58
N ₂ O	0.000	-	0.008	0.000	0.000	0.000	0.01
Lead	0.000	-	0.000	0.000	0.000	0.000	0.00
Formaldehyde	0.000	-	-	-	-	-	0.00
Annual (tpy)							
	1	2	3	4	5	6	Total
Stream Sent to Enclosed Combustor/Vapor Combustor	pilot(s)	added fuel stream(s)	Oil Tank Flash Emissions	Water Tank Flash Emissions	Oil Tank W/B Emissions	Water Tank W/B Emissions	-
NOx	0.017	-	1.613	0.036	0.079	0.000	1.75
CO	0.014	-	1.355	0.031	0.066	0.000	1.47
PM2.5	0.001	-	0.092	0.002	0.004	0.000	0.10
PM10	0.001	-	0.123	0.003	0.006	0.000	0.13
H ₂ S	0.000	-	0.000	0.000	0.000	0.000	0.00
SO ₂	0.000	-	0.000	0.000	0.000	0.000	0.00
CO ₂	19.868	-	-	-	-	-	19.87
Total VOC	0.001	-	30.765	0.047	1.440	0.000	32.25
Benzene	0.000	-	0.021	0.000	0.000	0.000	0.02
Toluene	0.000	-	0.031	0.000	0.000	0.000	0.03
Ethylbenzene	0.000	-	0.012	0.000	0.000	0.000	0.01
Xylenes	0.000	-	0.028	0.000	0.000	0.000	0.03
n-Hexane	0.000	-	2.427	0.000	0.007	0.000	2.43
HAP	0.000	-	2.519	0.002	0.008	0.000	2.53
N ₂ O	0.000	-	0.035	0.001	0.002	0.000	0.04
Lead	0.000	-	0.000	0.000	0.000	0.000	0.00
Formaldehyde	0.000	-	-	-	-	-	0.00

Enclosed Combustor/Vapor Combustor Total Emissions		
	Hourly Emissions (lb/hr)	Annual Emissions (tpy)
Total VOC	7.36	32.25
NOx	3.99E-01	1.75E+00
CO	3.35E-01	1.47E+00
PM2.5	2.27E-02	9.95E-02
PM10	3.03E-02	1.33E-01
H ₂ S	1.21E-05	5.28E-05
SO ₂	2.27E-05	9.93E-05
Benzene (TAPs)	4.80E-03	2.10E-02
Toluene	7.24E-03	3.17E-02
Ethylbenzene	2.81E-03	1.23E-02
Xylenes	6.56E-03	2.87E-02
Hexanes	5.56E-01	2.43E+00
Formaldehyde (TAPs)	2.84E-06	1.24E-05
HAPs	0.58	2.53
CO ₂ e	1416.80	6205.58
N ₂ O	8.77E-03	3.84E-02
Lead	1.99E-06	8.73E-06

Enter any notes here as needed
1. Emission Factors from AP-42 Tables 1.4-1, 1.4-2, and 1.4.3

Table 11

**Enclosed Combustor GHG Emissions
Vogt Well Pad
Doddridge County, West Virginia
Antero Resources Corporation**

Enclosed Combustor CO₂ and CH₄ Emissions

Components	Mole fraction of oil flash gas constituents ^a	Volume of oil flash gas sent to Enclosed Combustor scf/year	Mole fraction of water flash gas constituents ^a	Volume of water flash gas sent to Enclosed Combustor scf/year	Mole fraction of oil tank vapors constituents ^a	Volume of oil tank vapor sent to Enclosed Combustor scf/year	Mole fraction of water tank vapors constituents ^a	Volume of water tank vapors sent to Enclosed Combustor scf/year	Component volume of gas sent to Enclosed Combustor scf/year	Number of carbon atoms	Combustion Efficiency	Combusted CO ₂ Volume ^b scf/year	Uncombusted CO ₂ and CH ₄ Volume ^b scf/year	Volume GHGs Emitted scf/year
CO ₂	0.001	32,267,508	0.0166	728,748	0.0012	1,576,785	0.020	7,909	53,169	1	0	--	53,169	105,318,818
Methane	0.072	32,267,508	0.7535	728,748	0.0147	1,576,785	0.037	7,909	2,891,769	1	0.98	2,833,933	57,835	57,835
Ethane	0.262	32,267,508	0.1389	728,748	0.3358	1,576,785	0.006	7,909	9,068,762	2	0.98	17,774,774	--	
Propane	0.313	32,267,508	0.0428	728,748	0.3392	1,576,785	0.000	7,909	10,664,949	3	0.98	31,354,949	--	
i-Butane	0.064	32,267,508	0.0017	728,748	0.0642	1,576,785	0.000	7,909	2,156,434	4	0.98	8,453,220	--	
n-Butane	0.148	32,267,508	0.0070	728,748	0.1486	1,576,785	0.000	7,909	5,018,995	4	0.98	19,674,461	--	
Pentane	0.086	32,267,508	0.0022	728,748	0.0804	1,576,785	0.000	7,909	2,902,228	5	0.98	14,220,916	--	
Hexane	0.039	32,267,508	0.0004	728,748	0.0069	1,576,785	0.000	7,909	1,278,011	6	0.98	7,514,704	--	
Benzene	0.000	32,267,508	0.0002	728,748	0.0000	1,576,785	0.000	7,909	10,499	6	0.98	61,732	--	
Heptanes	0.008	32,267,508	0.0002	728,748	0.0048	1,576,785	0.000	7,909	254,146	7	0.98	1,743,441	--	
Toluene	0.000	32,267,508	0.0003	728,748	0.0000	1,576,785	0.000	7,909	13,413	7	0.98	92,010	--	
Octane	0.005	32,267,508	0.0001	728,748	0.0037	1,576,785	0.000	7,909	157,565	8	0.98	1,235,312	--	
Ethyl benzene	0.000	32,267,508	0.0001	728,748	0.0000	1,576,785	0.000	7,909	4,523	8	0.98	35,460	--	
Xylenes	0.000	32,267,508	0.0002	728,748	0.0001	1,576,785	0.000	7,909	10,550	8	0.98	82,710	--	
Nonane	0.001	32,267,508	0.0000	728,748	0.0004	1,576,785	0.000	7,909	18,443	9	0.98	162,664	--	
Decane plus	0.000	32,267,508	0.0000	728,748	0.0000	1,576,785	0.000	7,909	2,588	10	0.98	25,362	--	
Subtotal												105,265,649	--	

Pollutant	Volume Emitted scf/year	Density of GHG ^c lb/scf	Conversion Factor lb/ton	GWF	Emissions ^c	
					lbs/hr	(tons/yr)
CO ₂	105,318,818	0.12	2000	1	1394.19	6,106.54
CH ₄	57,835	0.09	2000	25	0.61	2.69
CO₂e Emissions					1,409.5	6173.80

GHG Emissions Summary

Notes

a Flashing/Working/Breathing Losses from ProMax output reports

b 40 CFR 98.233 (n)(4): Eqns: W-19, W-20 and W-21

c 40 CFR 98.233(v) Eqn W-36 - density at 60F and 14.7 psia

Table 12

**Haul Road Emissions
Vogt Well Pad
Doddridge County, West Virginia
Antero Resources Corporation**

	PM	PM10
Particle Size Multiplier (k)	0.8	0.36
Silt Content of Road Surface Material (s) (%)	5.1	5.1
Days per Year with Precipitation > 0.01 in (p)	150	150
Control Efficiency for Watering ¹ (%)	50	50

Tanker Truck Trip Calculation	
Condensate Production (bbl/day)	608
PW Production (bbl/day)	490
Truck Capacity (bbl)	200

Pick Up Truck Trip Calculation	
No of Trips Per day	2
Trips Per Year	730

	# of Wheels	Mean Vehicle Weight (W) (tons)	Mean Vehicle Speed (S) (mph)	Miles Per Trip (miles)	Maximum Trips per Hour	Maximum Trips per Year	Vehicle Miles Travelled		PM (lbs/VMT)	PM10 (lbs/VMT)
							(miles/hr)	(miles/year)		
Tanker Trucks Condensate	10	40	10	0.9600	1	1110	0.9600	1065.6000	3.8175	1.7179
Tanker Trucks PW	10	40	10	0.9600	1	895	0.9600	859.2000	3.8175	1.7179
Pick Up Truck	4	3	10	0.2100	1	730	0.2100	153.3000	0.3467	0.1560

	Uncontrolled Emissions						Controlled Emissions					
	(lbs/hr)	PM (lbs/year)	(tpy)	(lbs/hr)	PM10 (lbs/year)	(tpy)	(lbs/hr)	PM (lbs/year)	(tpy)	(lbs/hr)	PM10 (lbs/year)	(tpy)
Tanker Trucks Condensate	3.6648	4067.9593	2.0340	1.6492	1830.5817	0.9153	1.8324	2033.9797	1.0170	0.8246	915.2908	0.4576
Tanker Trucks PW	3.6648	3280.0213	1.6400	1.6492	1476.0096	0.7380	1.8324	1640.0106	0.8200	0.8246	738.0048	0.3690
Pick Up Truck	0.0728	53.1460	0.0266	0.0328	23.9157	0.0120	0.0364	26.5730	0.0133	0.0164	11.9578	0.0060
Total Emissions	7.4025	7,401.1266	3.7006	3.3311	3,330.5070	1.6653	3.7012	3,700.5633	1.8503	1.6656	1,665.2535	0.8326

Enter any notes here:	1 EPA, AP-42, Volume I, Section 13.2.2 Unpaved Roads (11/06); assume 2:1 moisture ratio Section 13.2.2 Unpaved Roads (11/06) Source: Attachment L, Fugitive Emissions from Unpaved Haul Roads, Rev 03/2007, West Virginia Department of Environmental Protection
------------------------------	---

Table 13

**Engine Emissions
Vogt Well Pad
Doddridge County, West Virginia
Antero Resources Corporation**

Kubota DG972-E2

Power (hp)	24
Fuel consumption (lbs/BHP-hr)	0.449
Heat Content of Fuel (Btu/scf)	1218.948
Density of NG (lb/scf)	0.056
Operating Hours/year	8760
No. of Engines	1

Pollutant	Emission Factors		lb/hr	tpy
	(g/hp-hr)	(lb/MMBtu)		
NOx ¹	5.97		0.3158	1.3831
CO ²	106.7		5.6445	24.7228
CO ₂		110.000	25.8016	113.01
PM _{2.5}		9.500E-03	0.0022	0.0098
PM ₁₀		9.500E-03	0.0022	0.0098
PM (Total)		9.910E-03	0.0023	0.0102
SO ₂		5.880E-04	0.0001	0.0006
TOC		0.358	0.0840	0.3678
Methane		0.230	0.0539	0.2363
VOC ³		0.0296	0.0069	0.0304
HAPS				
Benzene		1.58E-03	3.71E-04	1.62E-03
Ethylbenzene		2.48E-05	5.82E-06	2.55E-05
Formaldehyde		2.05E-02	4.81E-03	2.11E-02
Naphthalene		9.71E-05	2.28E-05	9.98E-05
Toluene		5.58E-04	1.31E-04	5.73E-04
Xylene		1.95E-04	4.57E-05	2.00E-04

	lb/hr	tpy
TOTAL Uncontrolled VOC	6.94E-03	3.04E-02
TOTAL Uncontrolled NOx	3.16E-01	1.38E+00
TOTAL Uncontrolled HAPs	5.38E-03	2.36E-02
TOTAL Uncontrolled TAPs (Benzene)	3.71E-04	1.62E-03
TOTAL Uncontrolled Toluene	1.31E-04	5.73E-04
TOTAL Uncontrolled Ethylbenzene	5.82E-06	2.55E-05
TOTAL Uncontrolled Xylenes	4.57E-05	2.00E-04
TOTAL Uncontrolled TAPs (Formaldehyde)	4.81E-03	2.11E-02
TOTAL CO _{2e} Emissions	2.72E+01	1.19E+02

Enter Any Notes Here:

1. Emission factor used for the 24 HP engine's NOx is the 40 CFR 1054 standard indicated on the EPA's Certificate of Conformity. See Appendix N.
2. Emission factor for CO was the Certification CO level taken from EPA's Non-Road Small SI 2013 Certification issued by Office of Transportation and Air Quality, March 2014.
3. Emission factors for all other contaminants including VOCs were obtained from AP-42, Section 3.2 "Natural Gas-fired Reciprocating Engines", Table 3.2-3.

Table 14

**Change in Regulated Air Pollutants Emissions
Vogt Well Pad
Doddridge County, West Virginia
Antero Resources Corporation**

Pollutant	Potential Emissions		Initial Permit Application Emissions		Change in Emissions	
	Hourly PTE	Yearly PTE	Hourly PTE	Yearly PTE	Hourly PTE	Yearly PTE
PM	3.9520	2.9485	7.3164	28.4200	-3.3644	-25.4715
PM10	1.9163	1.9309	1.9884	8.7000	-0.0721	-6.7691
VOC (uncontrolled)	372.0493	1635.8048	175.6380	769.2401	196.4113	866.5648
CO	8.3912	36.7533	10.4000	45.7000	-2.0088	-8.9467
NOx	3.5856	15.7051	1.9930	8.8600	1.5926	6.8451
SO2	0.0174	0.0762	0.0076	0.0327	9.84E-03	4.35E-02
Pb	1.63E-05	7.16E-05	0.0000	0.0000	1.01E-05	4.46E-05
HAPs	1.0078	4.4496	0.5251	2.3000	0.4827	2.1496
TAPs	0.0202	0.0885	0.0215	0.0940	-1.31E-03	-0.0055

Notes:

1. Change in emissions due to the increase in condensate production, addition of 2 Cimarron enclosed combustors, and 10 line heaters.
2. Change in permit from G70A to G70C.



Bryan Research & Engineering, Inc.

ProMax[®] 3.2

with
TSWEET[®] & PROSIM[®]

Copyright © BRE Group, Ltd. 2002-2011. All Rights Reserved.

Simulation Report

Client Name:	Antero Resources Corporation
Location:	West Virginia
Job:	Vogt Well Pad
Project Name:	PROMAX SCENARIO 3
File Name:	\\Det-s1\shared\AirQuality\ANTERO RESOURCES\ProMax\Antero WV_Old_2 Ph Separator\ProMax Model\PROMAX SCENARIO 3.pmx
ProMax Version:	
Report Created:	6/13/2016 11:33

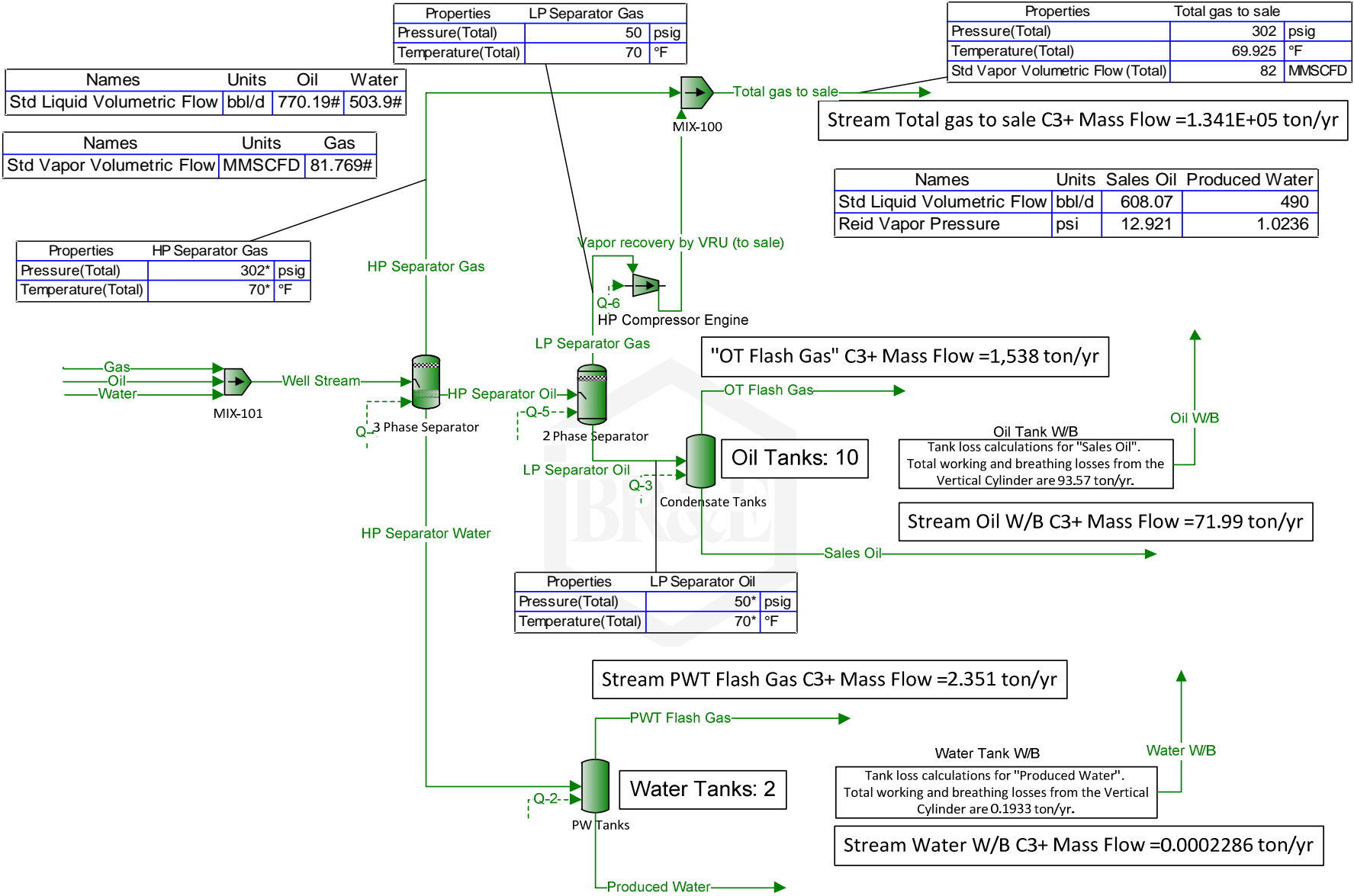

Properties		LP Separator Gas	
Pressure(Total)		50	psig
Temperature(Total)		70	°F

Properties		Total gas to sale	
Pressure(Total)		302	psig
Temperature(Total)		69.925	°F
Std Vapor Volumetric Flow (Total)		82	MMSCFD

Names	Units	Oil	Water
Std Liquid Volumetric Flow	bbl/d	770.19#	503.9#

Names	Units	Gas
Std Vapor Volumetric Flow	MMSCFD	81.769#

Properties		HP Separator Gas	
Pressure(Total)		302*	psig
Temperature(Total)		70*	°F

Stream Total gas to sale C3+ Mass Flow = 1.341E+05 ton/yr

Names	Units	Sales Oil	Produced Water
Std Liquid Volumetric Flow	bbl/d	608.07	490
Reid Vapor Pressure	psi	12.921	1.0236

Properties		LP Separator Oil	
Pressure(Total)		50*	psig
Temperature(Total)		70*	°F

"OT Flash Gas" C3+ Mass Flow = 1,538 ton/yr

Stream Oil W/B C3+ Mass Flow = 71.99 ton/yr

Stream PWT Flash Gas C3+ Mass Flow = 2.351 ton/yr

Water Tank W/B
Tank loss calculations for "Produced Water".
Total working and breathing losses from the Vertical Cylinder are 0.1933 ton/yr.

Stream Water W/B C3+ Mass Flow = 0.0002286 ton/yr

Oil Tank W/B
Tank loss calculations for "Sales Oil".
Total working and breathing losses from the Vertical Cylinder are 93.57 ton/yr.

Water Tanks: 2

Oil Tanks: 10

Isopentane	5.82240E-05	5.82240E-05										4.68843E-05	9.37278E-05				
n-Pentane	5.54752E-05	5.54752E-05										4.72916E-05	7.74088E-05				
2-Methylpentane	1.70511E-06	1.70511E-06										1.31047E-06	1.19726E-06				
3-Methylpentane	3.25133E-06	3.25133E-06										2.40790E-06	2.11681E-06				
n-Hexane	1.45901E-05	1.45901E-05										1.07883E-05	7.90036E-06				
Methylcyclopentane	5.20087E-06	5.20087E-06										3.56330E-06	2.96373E-06				
Benzene	7.94432E-05	7.94432E-05										6.06191E-05	5.32030E-05				
2-Methylhexane	9.50255E-07	9.50255E-07										5.68839E-07	2.57794E-07				
3-Methylhexane	7.98145E-07	7.98145E-07										4.88225E-07	2.09605E-07				
Heptane	1.54858E-06	1.54858E-06										8.43754E-07	3.40507E-07				
Methylcyclohexane	5.93438E-06	5.93438E-06										4.21787E-06	1.36052E-06				
Toluene	8.00494E-05	8.00494E-05										6.10358E-05	1.71557E-05				
Octane	8.44749E-07	8.44749E-07										6.27998E-07	6.49026E-08				
Ethylbenzene	2.41791E-05	2.41791E-05										1.78372E-05	1.85877E-06				
m-Xylene	2.81947E-05	2.81947E-05										2.17725E-05	1.83501E-06				
o-Xylene	3.95494E-05	3.95494E-05										3.17808E-05	2.35081E-06				
Nonane	2.60557E-07	2.60557E-07										2.0603E-07	5.73323E-09				
C10+	2.40587E-07	2.40587E-07										2.31002E-07	4.23961E-10				
Mass Fraction	%	%	%	%	%	%	%	%	%	%	%	%	%	%	%	%	%
Water	99.9389	99.9389										99.8658	99.9224				
H2S	0	0										0	0				
Nitrogen	0.000232077	0.000232077									0.000711331	5.57054E-05					
Carbon Dioxide	0.00400507	0.00400507									0.00653871	0.00642000					
Methane	0.0354608	0.0354608									0.0917194	0.0231244					
Ethane	0.0123493	0.0123493									0.0228037	0.0268235					
Propane	0.00560419	0.00560419									0.00734613	0.0164200					
Isobutane	0.000274758	0.000274758									0.000301582	0.000724499					
n-Butane	0.00119929	0.00119929									0.00130072	0.00288712					
Isopentane	0.000233158	0.000233158									0.000187747	0.000375274					
n-Pentane	0.000222151	0.000222151									0.000189378	0.000309935					
2-Methylpentane	8.15562E-06	8.15562E-06									6.26795E-06	5.72561E-06					
3-Methylpentane	1.55512E-05	1.55512E-05									1.15170E-05	1.01232E-05					
n-Hexane	6.97851E-05	6.97851E-05									5.16002E-05	3.77817E-05					
Methylcyclopentane	2.42940E-05	2.42940E-05									1.66445E-05	1.38418E-05					
Benzene	0.000344424	0.000344424									0.000262810	0.000230624					
2-Methylhexane	5.28490E-06	5.28490E-06									3.16360E-06	1.43351E-06					
3-Methylhexane	4.43893E-06	4.43893E-06									2.71527E-06	1.16555E-06					
Heptane	8.61253E-06	8.61253E-06									4.69254E-06	1.89345E-06					
Methylcyclohexane	3.23404E-05	3.23404E-05									2.29858E-05	7.41318E-06					
Toluene	0.000409373	0.000409373									0.000312135	8.77206E-05					
Octane	5.35578E-06	5.35578E-06									3.98153E-06	4.11422E-07					
Ethylbenzene	0.000142476	0.000142476									0.000105105	1.09511E-05					
m-Xylene	0.000166138	0.000166138									0.000128294	1.08111E-05					
o-Xylene	0.000233046	0.000233046									0.000187268	1.38500E-05					
Nonane	1.85480E-06	1.85480E-06									1.42800E-06	4.08061E-08					
C10+	2.18462E-06	2.18462E-06									2.09756E-06	3.84911E-09					
Mass Flow	lb/h	lb/h	lb/h	lb/h	lb/h	lb/h	lb/h	lb/h	lb/h	lb/h	lb/h	lb/h	lb/h	lb/h	lb/h	lb/h	lb/h
Water	0	0										7228.02	0.212783				
H2S	0	0										0	0				
Nitrogen	0	0										0.0514843	1.18624E-07				
Carbon Dioxide	0	0										0.618009	1.36713E-05				
Methane	0	0										6.63840	4.92429E-05				
Ethane	0	0										1.65047	5.71202E-05				
Propane	0	0										0.531693	3.49661E-05				
Isobutane	0	0										0.0218277	1.54281E-06				
n-Butane	0	0										0.0941429	6.14807E-06				
Isopentane	0	0										0.0135886	7.99140E-07				
n-Pentane	0	0										0.0137067	6.60001E-07				
2-Methylpentane	0	0										0.000453658	1.21926E-08				
3-Methylpentane	0	0										0.000833566	2.15571E-08				
n-Hexane	0	0										0.00373468	8.04554E-08				

Methylcyclopentane	0	0	0	0	0	0	0	0	0	0	0	0	0	0.00120469	2.94759E-08
Benzene	0	0	0	0	0	0	0	0	0	0	0	0	0	0.0190215	4.91110E-07
2-Methylhexane	0	0	0	0	0	0	0	0	0	0	0	0	0	0.000228973	3.05263E-09
3-Methylhexane	0	0	0	0	0	0	0	0	0	0	0	0	0	0.000196524	2.48201E-09
Heptane	0	0	0	0	0	0	0	0	0	0	0	0	0	0.000339634	4.03206E-09
Methylcyclohexane	0	0	0	0	0	0	0	0	0	0	0	0	0	0.00166365	1.57862E-08
Toluene	0	0	0	0	0	0	0	0	0	0	0	0	0	0.0225915	1.86799E-07
Octane	0	0	0	0	0	0	0	0	0	0	0	0	0	0.000288172	8.76116E-10
Ethylbenzene	0	0	0	0	0	0	0	0	0	0	0	0	0	0.00760722	2.33202E-08
m-Xylene	0	0	0	0	0	0	0	0	0	0	0	0	0	0.00928559	2.30221E-08
o-Xylene	0	0	0	0	0	0	0	0	0	0	0	0	0	0.0135539	2.94934E-08
Nonane	0	0	0	0	0	0	0	0	0	0	0	0	0	0.000103355	8.68959E-11
C10+	0	0	0	0	0	0	0	0	0	0	0	0	0	0.000151816	8.19661E-12

Process Streams		HP Separator Gas	HP Separator Water	HP Separator Oil	OT Flash Gas	Sales Oil	Gas	Water	Oil	Produced Water	PWT Flash Gas	Oil W/B	Water W/B	Well Stream	LP Separator Oil	LP Separator Gas	Vapor recovery by VRU (to sale)	Total gas to sale
Phase: Heavy Liquid	Status	Solved	Solved	Solved	Solved	Solved	Solved	Solved	Solved	Solved	Solved	Solved	Solved	Solved	Solved	Solved	Solved	Solved
Property	Units																	
Temperature	°F	70.0		70.0										84.5403			70	
Pressure	psig	302		302										1000			302	
Mole Fraction Vapor	%	0		0										0			0	
Mole Fraction Light Liquid	%	0		0										0			0	
Mole Fraction Heavy Liquid	%	100		100										100			100	
Molecular Weight	lb/lbmol	18.0		18.0										18.0170			18.0197	
Mass Density	lb/ft³	62.3		62.3										62.0907			62.2965	
Molar Flow	lbmol/h	0.0		0.0										401.716			0.0118175	
Mass Flow	lb/h	0.0		0.0										7237.73			0.212948	
Vapor Volumetric Flow	MCFH	0.0		0.0										0.116567			3.42050E-06	
Liquid Volumetric Flow	Mbb/d	0.0		0.0										0.498276			1.46212E-05	
Std Vapor Volumetric Flow	MMSCFD	0.0		0.0										3.65868			0.000107629	
Std Liquid Volumetric Flow	Mbb/d	0.0		0.0										0.497392			1.46133E-05	
Compressibility		0.016		0.016										0.0504153			0.0161264	
Specific Gravity		0.998		0.998										0.995537			0.998196	
API Gravity		10.1		10.1										10.0994			10.0564	
Enthalpy	MMBtu/h	0.0		0.0										-49.2529			-0.00145310	
Mass Enthalpy	Btu/lb	-6824.7		-6824.7										-6805.02			-6823.71	
Mass Cp	Btu/(lb*°F)	1.0		1.0										0.981395			0.982970	
Ideal Gas CpCv Ratio		1.326		1.326										1.32506			1.32575	
Dynamic Viscosity	cP	1.0		1.0										0.836494			0.995671	
Kinematic Viscosity	cSt	1.0		1.0										0.841038			0.998414	
Thermal Conductivity	Btu/(h*ft*°F)	0.3		0.3										0.351808			0.346149	
Surface Tension	lb/ft	0.005		0.005										0.00492118			0.00503670	
Net I.G. Heating Value	Btu/ft³	0.6		0.6										1.25538			0.695500	
Net Liquid Heating Value	Btu/lb	-1047.2		-1047.2										-1031.95			-1044.37	
Gross I.G. Heating Value	Btu/ft³	50.9		50.9										51.6350			51.0463	
Gross Liquid Heating Value	Btu/lb	13.1		13.1										29.2			16.0	

FESCO, Ltd.
1100 FESCO Avenue - Alice, Texas 78332

For: Antero Resources Appalachian Corp.
 1625 17th Street
 Denver, Colorado 80202

Sample: Seaborne No. 1H (Vogt Pad well sample)
 Separator Hydrocarbon Liquid
 Sampled @ 320 psig & 72 °F

Date Sampled: 09/20/13

Job Number: 35820.002

CHROMATOGRAPH EXTENDED ANALYSIS - GPA 2186-M

COMPONENT	MOL %	LIQ VOL %	WT %
Nitrogen	0.026	0.007	0.008
Carbon Dioxide	0.022	0.009	0.011
Methane	7.703	3.192	1.406
Ethane	7.916	5.177	2.708
Propane	7.595	5.117	3.810
Isobutane	2.047	1.638	1.353
n-Butane	5.957	4.593	3.939
2,2 Dimethylpropane	0.080	0.075	0.066
Isopentane	3.263	2.918	2.678
n-Pentane	4.477	3.969	3.675
2,2 Dimethylbutane	0.231	0.236	0.226
Cyclopentane	0.000	0.000	0.000
2,3 Dimethylbutane	0.514	0.515	0.504
2 Methylpentane	2.662	2.702	2.610
3 Methylpentane	1.907	1.904	1.870
n-Hexane	4.853	4.880	4.758
Heptanes Plus	<u>50.748</u>	<u>63.069</u>	<u>70.379</u>
Totals:	100.000	100.000	100.000

Characteristics of Heptanes Plus:

Specific Gravity -----	0.7601	(Water=1)
°API Gravity -----	54.66	@ 60°F
Molecular Weight -----	121.9	
Vapor Volume -----	19.79	CF/Gal
Weight -----	6.33	Lbs/Gal

Characteristics of Total Sample:

Specific Gravity -----	0.6812	(Water=1)
°API Gravity -----	76.24	@ 60°F
Molecular Weight -----	87.9	
Vapor Volume -----	24.60	CF/Gal
Weight -----	5.68	Lbs/Gal

Base Conditions: 14.850 PSI & 60 °F

Certified: FESCO, Ltd. - Alice, Texas

Analyst: XG
 Processor: JCdjv
 Cylinder ID: W-1016

 David Dannhaus 361-661-7015

TANKS DATA INPUT REPORT

COMPONENT	Mol %	LiqVol %	Wt %
Carbon Dioxide	0.022	0.009	0.011
Nitrogen	0.026	0.007	0.008
Methane	7.703	3.192	1.406
Ethane	7.916	5.177	2.708
Propane	7.595	5.117	3.810
Isobutane	2.047	1.638	1.353
n-Butane	6.037	4.668	4.005
Isopentane	3.263	2.918	2.678
n-Pentane	4.477	3.969	3.675
Other C-6's	5.314	5.356	5.209
Heptanes	12.616	13.622	14.000
Octanes	14.845	16.794	18.294
Nonanes	6.279	8.213	9.061
Decanes Plus	13.338	21.169	24.822
Benzene	0.310	0.212	0.276
Toluene	0.818	0.670	0.858
E-Benzene	0.657	0.620	0.794
Xylenes	1.883	1.768	2.275
n-Hexane	4.853	4.880	4.758
2,2,4 Trimethylpentane	<u>0.000</u>	<u>0.000</u>	<u>0.000</u>
Totals:	100.000	100.000	100.000

Characteristics of Total Sample:

Specific Gravity -----	0.6812 (Water=1)
°API Gravity -----	76.24 @ 60°F
Molecular Weight-----	87.9
Vapor Volume -----	24.60 CF/Gal
Weight -----	5.68 Lbs/Gal

Characteristics of Decanes (C10) Plus:

Specific Gravity -----	0.7987 (Water=1)
Molecular Weight-----	163.6

Characteristics of Atmospheric Sample:

°API Gravity -----	63.19 @ 60°F
Reid Vapor Pressure (ASTM D-5191)-----	4.45 psi

QUALITY CONTROL CHECK			
	Sampling Conditions	Test Samples	
Cylinder Number	-----	W-1016*	T-3025
Pressure, PSIG	320	302	301
Temperature, °F	72	70	70

* Sample used for analysis

TOTAL EXTENDED REPORT

COMPONENT	Mol %	LiqVol %	Wt %
Nitrogen	0.026	0.007	0.008
Carbon Dioxide	0.022	0.009	0.011
Methane	7.703	3.192	1.406
Ethane	7.916	5.177	2.708
Propane	7.595	5.117	3.810
Isobutane	2.047	1.638	1.353
n-Butane	5.957	4.593	3.939
2,2 Dimethylpropane	0.080	0.075	0.066
Isopentane	3.263	2.918	2.678
n-Pentane	4.477	3.969	3.675
2,2 Dimethylbutane	0.231	0.236	0.226
Cyclopentane	0.000	0.000	0.000
2,3 Dimethylbutane	0.514	0.515	0.504
2 Methylpentane	2.662	2.702	2.610
3 Methylpentane	1.907	1.904	1.870
n-Hexane	4.853	4.880	4.758
Methylcyclopentane	1.031	0.892	0.987
Benzene	0.310	0.212	0.276
Cyclohexane	1.009	0.840	0.966
2-Methylhexane	2.934	3.336	3.345
3-Methylhexane	2.426	2.723	2.765
2,2,4 Trimethylpentane	0.000	0.000	0.000
Other C-7's	0.828	0.881	0.935
n-Heptane	4.388	4.950	5.002
Methylcyclohexane	3.402	3.344	3.800
Toluene	0.818	0.670	0.858
Other C-8's	8.240	9.437	10.332
n-Octane	3.203	4.013	4.162
E-Benzene	0.657	0.620	0.794
M & P Xylenes	0.877	0.832	1.059
O-Xylene	1.007	0.936	1.216
Other C-9's	4.414	5.647	6.340
n-Nonane	1.865	2.566	2.721
Other C-10's	3.956	5.561	6.358
n-decane	1.123	1.685	1.817
Undecanes(11)	3.018	4.353	5.047
Dodecanes(12)	1.740	2.710	3.186
Tridecanes(13)	1.212	2.024	2.412
Tetradecanes(14)	0.714	1.277	1.543
Pentadecanes(15)	0.441	0.846	1.034
Hexadecanes(16)	0.286	0.585	0.722
Heptadecanes(17)	0.207	0.449	0.559
Octadecanes(18)	0.165	0.377	0.471
Nonadecanes(19)	0.114	0.271	0.342
Eicosanes(20)	0.081	0.201	0.255
Heneicosanes(21)	0.065	0.168	0.214
Docosanes(22)	0.051	0.137	0.175
Tricosanes(23)	0.036	0.102	0.131
Tetracosanes(24)	0.030	0.088	0.114
Pentacosanes(25)	0.022	0.066	0.086
Hexacosanes(26)	0.020	0.064	0.083
Heptacosanes(27)	0.017	0.055	0.072
Octacosanes(28)	0.012	0.039	0.051
Nonacosanes(29)	0.010	0.033	0.044
Triacontan(30)	0.006	0.020	0.027
Hentriacontan Plus(31+)	<u>0.014</u>	<u>0.059</u>	<u>0.080</u>
Total	100.000	100.000	100.000



FESCO, Ltd.
1100 Fesco Avenue - Alice, Texas 78332

For: Antero Resources Appalachian Corp.
 1625 17th Street
 Denver, Colorado 80202

Date Sampled: 09/20/13

Date Analyzed: 10/02/13

Sample: Seaborne No. 1H (Vogt Pad well sample)

Job Number: J35820

FLASH LIBERATION OF HYDROCARBON LIQUID		
	Separator HC Liquid	Stock Tank
Pressure, psig	320	0
Temperature, °F	72	70
Gas Oil Ratio (1)	-----	327
Gas Specific Gravity (2)	-----	1.303
Separator Volume Factor (3)	1.1969	1.000

STOCK TANK FLUID PROPERTIES	
Shrinkage Recovery Factor (4)	0.8355
Oil API Gravity at 60 °F	63.19
Reid Vapor Pressure, psi (5)	4.45

Quality Control Check			
	Sampling Conditions	Test Samples	
Cylinder No.	-----	W-1016*	T-3025
Pressure, psig	320	302	301
Temperature, °F	72	70	70

(1) - Scf of flashed vapor per barrel of stock tank oil

(2) - Air = 1.000

(3) - Separator volume / Stock tank volume

(4) - Fraction of first stage separator liquid

(5) - Absolute pressure at 100 deg F

Analyst: _____ M. G. _____

* Sample used for flash study

Base Conditions: 14.85 PSI & 60 °F

Certified: FESCO, Ltd. - Alice, Texas

 David Dannhaus 361-661-7015

FESCO, Ltd.
1100 Fesco Ave. - Alice, Texas 78332

For: Antero Resources Appalachian Corp.
 1625 17th Street
 Denver, Colorado 80202

Sample: Seaborne No. 1H (Vogt Pad well sample)
 Gas Evolved from Hydrocarbon Liquid Flashed
 From 320 psig & 72 °F to 0 psig & 70 °F

Date Sampled: 09/20/13

Job Number: 35820.001

CHROMATOGRAPH EXTENDED ANALYSIS - SUMMATION REPORT

COMPONENT	MOL%	GPM
Hydrogen Sulfide*	< 0.001	
Nitrogen	0.084	
Carbon Dioxide	0.109	
Methane	28.979	
Ethane	27.515	7.417
Propane	21.197	5.886
Isobutane	3.988	1.315
n-Butane	9.085	2.887
2-2 Dimethylpropane	0.097	0.037
Isopentane	2.547	0.939
n-Pentane	2.631	0.961
Hexanes	2.134	0.886
Heptanes Plus	<u>1.634</u>	<u>0.724</u>
Totals	100.000	21.052

Computed Real Characteristics Of Heptanes Plus:

Specific Gravity ----- 3.558 (Air=1)
 Molecular Weight ----- 101.68
 Gross Heating Value ----- 5428 BTU/CF

Computed Real Characteristics Of Total Sample:

Specific Gravity ----- 1.303 (Air=1)
 Compressibility (Z) ----- 0.9868
 Molecular Weight ----- 37.25
 Gross Heating Value
 Dry Basis ----- 2191 BTU/CF
 Saturated Basis ----- 2153 BTU/CF

*Hydrogen Sulfide tested in laboratory by: Stained Tube Method (GPA 2377)

Results: <0.013 Gr/100 CF, <0.2 PPMV or <0.001 Mol %

Base Conditions: 14.850 PSI & 60 Deg F

Certified: FESCO, Ltd. - Alice, Texas

Analyst: MR
 Processor: ANB
 Cylinder ID: FL# 9 S

David Dannhaus 361-661-7015

**CHROMATOGRAPH EXTENDED ANALYSIS
TOTAL REPORT**

COMPONENT	MOL %	GPM	WT %
Hydrogen Sulfide*	< 0.001		< 0.001
Nitrogen	0.084		0.063
Carbon Dioxide	0.109		0.129
Methane	28.979		12.483
Ethane	27.515	7.417	22.213
Propane	21.197	5.886	25.095
Isobutane	3.988	1.315	6.223
n-Butane	9.085	2.887	14.177
2,2 Dimethylpropane	0.097	0.037	0.188
Isopentane	2.547	0.939	4.934
n-Pentane	2.631	0.961	5.097
2,2 Dimethylbutane	0.081	0.034	0.187
Cyclopentane	0.000	0.000	0.000
2,3 Dimethylbutane	0.128	0.053	0.296
2 Methylpentane	0.661	0.277	1.529
3 Methylpentane	0.408	0.168	0.944
n-Hexane	0.856	0.355	1.981
Methylcyclopentane	0.072	0.025	0.163
Benzene	0.024	0.007	0.050
Cyclohexane	0.109	0.037	0.246
2-Methylhexane	0.178	0.083	0.479
3-Methylhexane	0.178	0.082	0.479
2,2,4 Trimethylpentane	0.000	0.000	0.000
Other C7's	0.179	0.079	0.477
n-Heptane	0.248	0.115	0.667
Methylcyclohexane	0.177	0.072	0.467
Toluene	0.039	0.013	0.096
Other C8's	0.232	0.109	0.687
n-Octane	0.065	0.034	0.199
Ethylbenzene	0.002	0.001	0.006
M & P Xylenes	0.018	0.007	0.051
O-Xylene	0.002	0.001	0.006
Other C9's	0.070	0.036	0.237
n-Nonane	0.014	0.008	0.048
Other C10's	0.021	0.012	0.080
n-Decane	0.004	0.002	0.015
Undecanes (11)	<u>0.002</u>	<u>0.001</u>	<u>0.008</u>
Totals	100.000	21.052	100.000

Computed Real Characteristics Of Total Sample:

Specific Gravity -----	1.303	(Air=1)
Compressibility (Z) -----	0.9868	
Molecular Weight -----	37.25	
Gross Heating Value		
Dry Basis -----	2191	BTU/CF
Saturated Basis -----	2153	BTU/CF

Antero Resources
Seaborn Unit 1H - Vogt Pad

Tag Name	Value	Units	Timestamp
Accumulated Gas Flow	683627.1	MCF	12/5/2013 08:05:40
Casing Pressure	352.52	PSIA	12/5/2013 08:05:48
Current Day Gas Flow	49.19	MCF	12/5/2013 08:05:40
Differential Pressure	38.91	inH2O	12/5/2013 08:05:40
Flow Rate	6834.16	MCF Per Day	12/5/2013 08:05:40
Pressure	135.66	PSIA	12/5/2013 08:05:40
Previous Day Energy	8199.34	MBTU	12/5/2013 08:05:41
Previous Day Gas Flow	6726.57	MCF	12/5/2013 08:05:41
Temperature	68.72	F	12/5/2013 08:05:40
Tubing Pressure	606.04	PSIA	12/5/2013 08:05:48
Daily AP	37.24	PSIA	12/5/2013 09:00:00
Daily DP	137.62	inH2O	12/5/2013 09:00:00
Daily Energy	8199.34	MBTU	12/5/2013 09:00:00
Daily Flow	6726.57	MCF	12/5/2013 09:00:00
Daily Tf	68.49	F	12/5/2013 09:00:00
Hourly AP	134.4	PSIA	12/5/2013 09:00:00
Hourly DP	37.66	Inches	12/5/2013 09:00:00
Hourly Energy	339.8	MBTU	12/5/2013 09:00:00
Hourly Flow Time	3600	Seconds	12/5/2013 09:00:00
Hourly Tf	68.6	F	12/5/2013 09:00:00
Hourly Volume	278.8	MCF	12/5/2013 09:00:00
Audited Accumulated Gas Volume		MCF	
Audited Casing Pressure	383	PSI	12/2/2013 09:00:00
Audited Gas Volume	6544.49	MCF	12/2/2013 09:00:00
Audited Oil Volume	0	Barrels	12/2/2013 09:00:00
Audited Tubing Pressure	627	PSI	12/2/2013 09:00:00
Audited Water Volume	0	Barrels	12/2/2013 09:00:00
Argon	0	%	12/5/2013 08:05:47
BTU	1218.948	BTU	12/5/2013 08:05:40
CO2	0.1647	%	12/5/2013 08:05:47
Carbon Monoxide	0	%	12/5/2013 08:05:47
Decane	0	%	12/5/2013 08:05:47
Ethane	14.0689	%	12/5/2013 08:05:47
Helium	0	%	12/5/2013 08:05:47
Heptane	0	%	12/5/2013 08:05:47
Hexane	0.2484	%	12/5/2013 08:05:47
Hydrogen	0	%	12/5/2013 08:05:47
Hydrogen Sulfide	0	%	12/5/2013 08:05:47
Iso-Butane	0.5041	%	12/5/2013 08:05:47
Iso-Pentane	0.2618	%	12/5/2013 08:05:47
Methane	78.61509	%	12/5/2013 08:05:47
N2	0.564	%	12/5/2013 08:05:47
N-Butane	1.0298	%	12/5/2013 08:05:47
Nonane	0	%	12/5/2013 08:05:47
N-Pentane	0.2553	%	12/5/2013 08:05:47
Octane	0	%	12/5/2013 08:05:47
Oxygen	0.0715	%	12/5/2013 08:05:47
Plate Size	3.75	Inches	12/5/2013 08:05:45
Propane	4.2164	%	12/5/2013 08:05:47
SPG	0.7062		12/5/2013 08:05:40
Water	0	%	12/5/2013 08:05:47

Attachment T

Facility-wide Emissions Summary Sheet(s)

ATTACHMENT T – FACILITY-WIDE CONTROLLED EMISSIONS SUMMARY SHEET

List all sources of emissions in this table. Use extra pages if necessary.

Emission Point ID#	NOx		CO		VOC		SO2		PM10		PM2.5		GHG (CO2e)	
	lb/hr	tpy	lb/hr	tpy	lb/hr	tpy	lb/hr	tpy	lb/hr	tpy	lb/hr	tpy	lb/hr	tpy
EP-HR001									1.6656	0.8326				
EP-PCV					0.0968	0.4238							9.1402	40.0339
F001					3.6215	15.8620							84.1471	368.5643
EP-ENG001	0.316	1.383	5.644	24.723	0.007	0.030	0.000	0.001	0.002	0.010	0.002	0.010	27.15	118.92
EP-GPU001, EP-GPU002, EP-GPU003, EP-GPU004, EP-GPU005, EP-GPU006, EP-GPU007, EP-GPU008, EP-GPU009, EP-GPU010	1.2306	5.3899	1.0337	4.5275	0.0677	0.2964	0.0074	0.0323	0.0935	0.4096	0.0935	0.4096	1476.6832	6467.8723
EP-LH001, EP-LH002, EP-LH003, EP-LH004, EP-LH005, EP-LH006, EP-LH007, EP-LH008, EP-LH009, EP-LH010	1.6408	7.1865	1.3782	6.0367	0.0902	0.3953	0.0098	0.0431	0.1247	0.5462	0.1247	0.5462	1968.9109	8623.8297
EP-L001					13.4718	6.2285							2.3065	1.0664
EP-L002					0.001	4.37E-04							0.8402	0.3131
EP-EC001, EP-EC002, EP-EC003	0.3985	1.7456	0.3348	1.4663	7.3635	32.2523	2.27E-05	9.93E-05	0.0303	0.1327	0.0227	0.0995	1416.7980	6205.5753
TOTAL	3.5856	15.7051	8.3912	36.7533	7.5284	32.9744	0.0174	0.0762	0.2507	1.0982	0.2432	1.0651	4889.5424	21416.1959

Annual emissions shall be based on 8760 hours per year of operation for all emission units except emergency generators.

According to 45CSR14 Section 2.43.e, fugitive emissions are not included in the major source determination because it is not listed as one of the source categories in Table 1. Therefore, fugitive emissions shall not be included in the PTE above

ATTACHMENT T – FACILITY-WIDE CONTROLLED EMISSIONS SUMMARY SHEET

List all sources of emissions in this table. Use extra pages if necessary.

Emission Point ID#	Formaldehyde		Benzene		Toluene		Ethylbenzene		Xylenes		Hexane		Total HAPs	
	lb/hr	tpy	lb/hr	tpy	lb/hr	tpy	lb/hr	tpy	lb/hr	tpy	lb/hr	tpy	lb/hr	tpy
EP-HR001														
EP-PCV			0.00E+00	0.00E+00	0.00E+00	0.00E+00	0.00E+00	0.00E+00	0.00E+00	0.00E+00	0.0062	0.0272	0.0062	0.0272
F001			0.0080	0.0348	0.0248	0.1084	0.0229	0.1004	0.0657	0.2878	0.2435	1.0664	0.3648	1.5978
EP-ENG001	0.005	0.021	0.000	0.002	1.31E-04	5.73E-04	5.82E-06	2.55E-05	4.57E-05	2.00E-04			0.005	0.024
EP-GPU001, EP-GPU002, EP-GPU003, EP-GPU004, EP-GPU005, EP-GPU006, EP-GPU007, EP-GPU008, EP-GPU009, EP-GPU010	0.0009	0.0040	2.58E-05	1.13E-04	4.18E-05	0.0002			0.00E+00	0.00E+00	0.0222	0.0970	0.0232	0.1015
EP-LH001, EP-LH002, EP-LH003, EP-LH004, EP-LH005, EP-LH006, EP-LH007, EP-LH008, EP-LH009, EP-LH010	0.0012	0.0054	3.45E-05	0.0002	5.58E-05	2.44E-04			0.00E+00	0.00E+00	0.0295	0.1294	0.0309	0.1353
EP-L001			5.12E-04	2.37E-04	0.002	7.65E-04	0.001	5.53E-04	0.003	0.002	0.070	0.032	0.077	0.036
EP-L002			1.06E-06	3.97E-07	7.16E-07	2.67E-07	1.52E-07	5.67E-08	4.11E-07	1.53E-07	3.71E-09	1.38E-09	2.35E-06	8.75E-07
EP-EC001, EP-EC002, EP-EC003	2.84E-06	1.24E-05	0.0048	0.0210	0.0072	0.0317	0.0028	0.0123	0.0066	0.0287	0.5559	2.4350	0.5773	2.5287
TOTAL	0.0070	0.0305	0.0052	0.0229	0.0075	0.0327	0.0028	0.0123	0.0066	0.0289	0.6076	2.6613	0.6368	2.7891

Annual emissions shall be based on 8760 hours per year of operation for all emission units except emergency generators.

According to 45CSR14 Section 2.43.e, fugitive emissions are not included in the major source determination because it is not listed as one of the source categories in Table 1. Therefore, fugitive emissions shall not be included in the PTE above.

Attachment U

Class I Legal Advertisement

Attachment U

**Air Quality Permit Notice
Notice of Application
Vogt Well Pad
Antero Resources Corporation
Doddridge County, West Virginia**

Notice is given that Antero Resources Corporation has applied to the West Virginia Department of Environmental Protection, Division of Air Quality, for a G70-C General Permit Modification for an Oil and Natural Gas Production facility located at 130 Coopers Ridge Rd Greenwood, near West union in Doddridge County, West Virginia.

The latitude and longitude coordinates are: 39.277572 and -80.862125

The applicant estimates the increased potential to discharge the following Regulated Air Pollutants will be:

Pollutants	TOTALS (tpy):
NO _x	15.7051
CO	36.7533
PM _{2.5}	1.0651
PM ₁₀	1.0982
VOC	32.9744
SO ₂	0.0762
Formaldehyde	0.0305
Benzene	0.0229
Toluene	0.0327
Ethylbenzene	0.0123
Xylenes	0.0289
Hexane	2.6613
Total HAPs	2.7891

Proposed new equipment will be installed upon permit issuance. Startup of operation using new equipment is planned to begin on August 01, 2017. Written comments will be received by the West Virginia Department of Environmental Protection, Division of Air Quality, 601 57th Street, SE, Charleston, WV 25304, for at least 30 calendar days from the date of publication of this notice.

Any questions regarding this permit application should be directed to the DAQ at (304) 926-0499, extension 1250, during normal business hours.

Dated this the ___ day of _____, 2016

By: Antero Resources Corporation
Barry Schatz
Senior Environmental & Regulatory Manager
1615 Wynkoop Street
Denver, CO 80202

www.ghd.com

