



Carney, Jonathan W <jonathan.w.carney@wv.gov>

Union Carbide South Charleston

1 message

Whapham, Joseph <Whapham.Joseph@epa.gov>

Fri, Apr 19, 2024 at 2:44 PM

To: "McCumbers, Carrie" <Carrie.McCumbers@wv.gov>, Jonathan W Carney <jonathan.w.carney@wv.gov>

Cc: "Supplee, Gwendolyn" <Supplee.Gwendolyn@epa.gov>

Good Afternoon,

I did a deep dive into Subpart DDDDD, Subpart PPP, and the 2018 renewal for Union Carbide South Charleston. I then discussed with Gwen and we both agree the provisions for boiler MACT are in the permit as you stated. We believe the permit is ready to go to draft.

Thank you for your time and patients as we worked through this.

Thank you,

Adam

	<p>J. Adam Whapham Environmental Engineer Region 3, Air Permits Branch US EPA Mid-Atlantic Region Phone 215-814-2160 Email whapham.joseph@epa.gov</p> <p> </p>
---	---

West Virginia Department of Environmental Protection
Division of Air Quality

Harold D. Ward
Cabinet Secretary

Permit to Operate



Pursuant to
Title V
of the Clean Air Act

Issued to:
Union Carbide Corporation
South Charleston
R30-03900003-2024

Laura M. Crowder
Director, Division of Air Quality

Issued: [Date of issuance] • Effective: [Equals issue date plus two weeks]
Expiration: [5 years after issuance date] • Renewal Application Due: [6 months prior to expiration]

Permit Number: **R30-03900003-2024**
Permittee: **Union Carbide Corporation**
(A Subsidiary of The Dow Chemical Company)
Facility Name: **South Charleston**
Mailing Address: **PO Box 8361**
South Charleston, WV 25303

This permit is issued in accordance with the West Virginia Air Pollution Control Act (West Virginia Code §§ 22-5-1 et seq.) and 45CSR30 — Requirements for Operating Permits. The permittee identified at the above-referenced facility is authorized to operate the stationary sources of air pollutants identified herein in accordance with all terms and conditions of this permit.

Facility Location:	South Charleston, Kanawha County, West Virginia
Telephone Number:	(304) 747-7000
Type of Business Entity:	Corporation
Facility Description:	Industrial Organic Chemical Manufacturing
SIC Codes:	2869
UTM Coordinates:	440.026 km Easting • 4,246.927 km Northing • Zone 17

Permit Writer: Jonathan Carney

Any person whose interest may be affected, including, but not necessarily limited to, the applicant and any person who participated in the public comment process, by a permit issued, modified or denied by the Secretary may appeal such action of the Secretary to the Air Quality Board pursuant to article one [§§ 22B-1-1 et seq.], Chapter 22B of the Code of West Virginia. West Virginia Code §22-5-14.

Issuance of this Title V Operating Permit does not supersede or invalidate any existing permits under 45CSR13, 14 or 19, although all applicable requirements from such permits governing the facility's operation and compliance have been incorporated into the Title V Operating Permit.

Table of Contents

1.0	Emission Units and Active R13, R14, and R19 Permits.....	3
2.0	General Conditions.....	16
3.0	Facility-Wide Requirements.....	24
4.0	Source-Specific Requirements [Energy Systems].....	32
5.0	Source-Specific Requirements [Triton Surfactants]	43
6.0	Source-Specific Requirements [Middle Island Groundwater Containment System (MIGCS1 and MIGCS2).....	56
7.0	Source-Specific Requirements [Oxide Adducts (OA) & 40CFR63, Subpart PPP].	68
8.0	Source-Specific Requirements [45CSR27 Toxic Air Pollutants]	78
9.0	Source-Specific Requirements [45CSR21 Volatile Organic Compounds]	84
10.0	Source-Specific Requirement [Groundwater/Soil Remediation Chlorohydrin/ Chlorobenzene (SVE1, SVE2, and SVE3), Middle Island Source 2 (MI2VE2), and MIGCS (MIGCS1 and MIGCS2) Under 40 C.F.R. 63, Subpart GGGGG].....	88
11.0	Source-Specific Requirements [Groundwater/Soil Remediation Process (SVE1, SVE2, SVE3 and MI2VE2)]	104
12.0	Source-Specific Requirements [Chemical Mixing Unit].....	112
13.0	Source-Specific Requirements [Emergency Engines Under 40 C.F.R. 63, Subpart ZZZZ (RICE)]	114
14.0	Source-Specific Requirements [CAM for Groundwater/Soil Remediation Chlorohydrin/Chlorobenzene].....	118

ATTACHMENT A “Sample Record Keeping, Boiler 27, R13-2141C”

ATTACHMENT B “Attachment A to Regulation 21 Consent Order- Point Source Emissions”

ATTACHMENT C “Attachment B to Regulation 21 Consent Order – Excess Emissions Scenarios”

1.0 Emission Units and Active R13, R14, and R19 Permits

1.1. Emission Units

Emission Unit ID	Emission Point ID	Emission Unit Description	Year Installed	Design Capacity	Control Device
Energy Systems					
B26	26E	NG/Waste Gas Boiler	1996	352 MM Btu/hr	
B27	27E	NG/Waste Gas Boiler	1998	353 MM Btu/hr	
001	A-001	portable diesel auxiliary air compressors			
002	A-002	portable diesel auxiliary air compressors			
003	A-003	portable diesel auxiliary air compressors			
004	A-004	portable diesel auxiliary air compressors			
EOHDR	Fugitive	EO Distribution System			
Oxide Adducts					
9121	T9121	Tank 9121	1950	*****	
9128	T9128	Tank 9128	1953	*****	
9120	T9120	Tank 9120	1950	*****	
9129	T9129	Tank 9129	1953	*****	
9151	T9151	Tank 9151	1943	*****	
9180	T9180	Tank 9180	1957	*****	
9181	T9181	Tank 9181	1957	*****	
9182	T9182	Tank 9182	1957	*****	
9186	T9186	Tank 9186	1966	*****	
9187	T9187	Tank 9187	1966	*****	
9223	T9223	Tank 9223	1952	*****	
9228	T9228	Tank 9228	1947	*****	
9501	T9501	Tank 9501	1965	*****	
9502	T9502	Tank 9502	1968	*****	
9504	T9504	Tank 9504	1965	*****	
9505	T9505	Tank 9505	1965	*****	
9507	T9507	Tank 9507	1971	*****	
9509	T9509	Tank 9509	1978	*****	
9510	T9510	Tank 9510	1988	*****	
9511	T9511	Tank 9511	1990	*****	
9512	T9512	Tank 9512	1990	*****	
9513	T9513	Tank 9513	1990	*****	

Emission Unit ID	Emission Point ID	Emission Unit Description	Year Installed	Design Capacity	Control Device
9514	T9514	Tank 9514	1942	*****	
9550	T9550	Tank 9550	1978	*****	
9551	T9551	Tank 9551	1978	*****	
9552	T9552	Tank 9552	1978	*****	
9553	T9553	Tank 9553	1978	*****	
9554	T9554	Tank 9554	1978	*****	
9555	T9555	Tank 9555	1978	*****	
9556	T9556	Tank 9556	1967	*****	
9557	T9557	Tank 9557	1967	*****	
9558	T9558	Tank 9558	1967	*****	
9559	T9559	Tank 9559	1967	*****	
9560	T9560	Tank 9560	1961	*****	
9562	T9562	Tank 9562	1950	*****	
9563	T9563	Tank 9563	1972	*****	
9564	T9564	Tank 9564 (out of service)	1972	*****	
9565	T9565	Tank 9565	1954	*****	
9566	T9566	Tank 9566	1957	*****	
9567	T9567	Tank 9567	1953	*****	
9568	T9568	Tank 9568	1953	*****	
9569	T9569	Tank 9569	1966	*****	
9611	T9611	Tank 9611	1966	*****	
9612	T9612	Tank 9612	1966	*****	
9613	T9613	Tank 9613	1966	*****	
9614	T9614	Tank 9614	1966	*****	
9615	T9615	Tank 9615	1966	*****	
9616	T9616	Tank 9616	1966	*****	
9617	T9617	Tank 9617	1967	*****	
9619	T9619	Tank 9619	1967	*****	
9621	T9621	Tank 9621	1966	*****	
9622	T9622	Tank 9622	1966	*****	
9623	T9623	Tank 9623	1966	*****	
9624	T9624	Tank 9624	1966	*****	
9625	T9625	Tank 9625	1966	*****	
9627	T9627	Tank 9627	1967	*****	
9629	T9629	Tank 9629	1967	*****	
9631	T9631	Tank 9631	1947	*****	
9632	T9632	Tank 9632	1947	*****	
9633	T9633	Tank 9633	1945	*****	
9634	T9634	Tank 9634	1951	*****	
9635	T9635	Tank 9635	1951	*****	
9637	T9637	Tank 9637	1947	*****	
9638	T9638	Tank 9638	1947	*****	

Emission Unit ID	Emission Point ID	Emission Unit Description	Year Installed	Design Capacity	Control Device
9639	T9639	Tank 9639	1947	*****	
9640	T9640	Tank 9640	1948	*****	
9641	T9641	Tank 9641	1948	*****	
9642	T9642	Tank 9642	1948	*****	
9643	T9643	Tank 9643	1942	*****	
9644	T9644	Tank 9644	1942	*****	
9645	T9645	Tank 9645	1942	*****	
9646	T9646	Tank 9646	1947	*****	
9647	T9647	Tank 9647	1946	*****	
9648	T9648	Tank 9648	1946	*****	
9649	T9649	Tank 9649	1946	*****	
9650	T9650	Tank 9650	1964	*****	
9651	T9651	Tank 9651	1952	*****	
9656	T9656	Tank 9656	1953	*****	
9657	T9657	Tank 9657	1956	*****	
9732	T9732	Tank 9732	1956	*****	
9733	T9733	Tank 9733	1957	*****	
9734	T9734	Tank 9734	1940	*****	
9735	T9735	Tank 9735	1950	*****	
9736	T9736	Tank 9736	1940	*****	
9738	T9738	Tank 9738	1966	*****	
9740	T9740	Tank 9740	1949	*****	
9749	T9749	Tank 9749	1957	*****	
9750	T9750	Tank 9750 (Sulfuric Acid)	1981	*****	
9751	T9751	Tank 9751	1966	*****	
9752	T9752	Tank 9752	1966	*****	
9756	T9756	Tank 9756	Prior to 1984	*****	
9757	T9757	Tank 9757	2004	*****	
9771	T9771	Tank 9771	1966	*****	
9772	T9772	Tank 9772	1966	*****	
9773	T9773	Tank 9773	1966	*****	
9774	T9774	Tank 9774	1966	*****	
9775	T9775	Tank 9775	1966	*****	
9776	T9776	Tank 9776	1966	*****	
9781	T9781	Tank 9781	1966	*****	
9782	T9782	Tank 9782	1966	*****	
9783	T9783	Tank 9783	1966	*****	
9784	T9784	Tank 9784	1966	*****	
9785	T9785	Tank 9785	1966	*****	
9786	T9786	Tank 9786	1966	*****	
9793	T9793	Tank 9793	1964	*****	

Emission Unit ID	Emission Point ID	Emission Unit Description	Year Installed	Design Capacity	Control Device
9798	T9798	Tank 9798	1964	*****	
9811	T9811	Tank 9811	1966	*****	
9812	T9812	Tank 9812	1966	*****	
9813	T9813	Tank 9813	1966	*****	
9814	T9814	Tank 9814	1966	*****	
9815	T9815	Tank 9815	1966	*****	
9821	T9821	Tank 9821	1966	*****	
9822	T9822	Tank 9822	1966	*****	
9823	T9823	Tank 9823	1966	*****	
9824	T9824	Tank 9824	1966	*****	
9825	T9825	Tank 9825	1966	*****	
5694	T5694	Tank 5694	2012		
9636	T9636	Tank 9636	2012		
200	T200	Tank 200	2012		
P700	E700	Prep System 1	1970	*****	
P701	E701	Prep System 2	1970	*****	
P716	E716	Prep System 3	1970	*****	
R703	E703	Reactor 1	1970	*****	
R704	E704	Reactor 2	1970	*****	
R705	E705	Reactor 4	1970	*****	
R706	E706	Reactor 5	1970	*****	
R707	E707	Reactor 7	1971	*****	
R708	E708	Reactor 6	1995	*****	
721T	E709	#1 Product Treatment Emiss. Pt. for Vac Jet	1970	*****	C-709 and/or None
722T	E710	#2 Product Treatment Emiss. Pt. for Vac Jet	1970	*****	C-710 and/or None
723T	E711	#5 Product Treatment Emiss. Pt. for Vac Jet	1970	*****	C-711 and/or None
730HW	E730	Hotwell System	Nap	Nap	
732T	E732	Other Treatment	1970	*****	
717R1	E717	Recovery and Refining Systems 1	1970	*****	
717R2	E718	Recovery and Refining Systems 2	1970	*****	
L001	L001TT	Tank Truck Rack	Nap	Nap	
L002	L002RC	Rail Car Rack	Nap	Nap	

Emission Unit ID	Emission Point ID	Emission Unit Description	Year Installed	Design Capacity	Control Device
C709	E709 and/or E730	#1 Jets/Condenser	Nap	Nap	
C710	E710 and/or E730	#2 Jets/Condenser	Nap	Nap	
C711	E711 and/or E730	#5 Jets/Condenser	Nap	Nap	
Misc Drop Tanks	E703A - Virtual Emission Point for #1 Reactor Drop Tanks	R27 CO Process Id. E703A	Nap	Nap	
Misc Drop Tanks	E704A - Virtual Emission Point for #2 Reactor Drop Tanks	R27 CO Process Id. E704A	Nap	Nap	
Misc Drop Tanks	E705A - Virtual Emission Point for #4 Reactor Drop Tanks	R27 CO Process Id. E705A	Nap	Nap	
Misc Drop Tanks	E706A - Virtual Emission Point for #5 Reactor Drop Tanks	R27 CO Process Id. E706A	Nap	Nap	
Misc Drop Tanks	E707A - Virtual Emission Point for #7 Reactor Drop Tanks	R27 CO Process Id. E707A	Nap	Nap	
Misc Drop Tanks	E708A - Virtual Emission Point for #6 Reactor Drop Tanks	R27 CO Process Id. E708A	Nap	Nap	

Emission Unit ID	Emission Point ID	Emission Unit Description	Year Installed	Design Capacity	Control Device
Product Treatment 1, 2, 5, and/or Other Treatment	E703B - Virtual Emission Point for #1 Reactor Product Treatment	R27 CO Process Id. E703B Virtual because can treat products from reactor 1 in treater 2 or 5	Nap	Nap	
Product Treatment 1, 2, 5, and/or Other Treatment	E704B- Virtual Emission Point for #2 Reactor Product Treatment	R27 CO Process Id. E704B	Nap	Nap	
Product Treatment 1, 2, 5, and/or Other Treatment	E705B- Virtual Emission Point for #4 Reactor Product Treatment	R27 CO Process Id. E705B	Nap	Nap	
Product Treatment 1, 2, 5, and/or Other Treatment	E706B- Virtual Emission Point for #5 Reactor Product Treatment	R27 CO Process Id. E706B	Nap	Nap	
Product Treatment 1, 2, 5, and/or Other Treatment	E707B- Virtual Emission Point for #7 Reactor Product Treatment	R27 CO Process Id. E707B	Nap	Nap	
Product Treatment 1, 2, 5, and/or Other Treatment	E708B- Virtual Emission Point for #6 Reactor Product Treatment	R27 CO Process Id. E708B	Nap	Nap	

Emission Unit ID	Emission Point ID	Emission Unit Description	Year Installed	Design Capacity	Control Device
Chemical Mixing					
2001	2001E	Tank 2001	1962	*****	
2003	2003E	Tank 2003	1962	*****	
2005	2005E	Tank 2005	1962	*****	
2006	2006E	Tank 2006	1962	*****	
2007	2007E	Tank 2007	1962	*****	
2008	2008E	Tank 2008	1945	*****	
2009	2009E	Tank 2009	1962	*****	
2010	2010E	Tank 2010	1968	*****	
2011	2011E	Tank 2011	1962	*****	
2012	2012E	Tank 2012	1962	*****	
2014	2014E	Tank 2014	1962	*****	
2016	2016E	Tank 2016	1962	*****	
2017	2017E	Tank 2017	1956	*****	
2018	2018E	Tank 2018	1956	*****	
2019	2019E	Tank 2019	1953	*****	
2020	2020E	Tank 2020	1953	*****	
2040	2040E	Tank 2040	1962	*****	
2041	2041E	Tank 2041	1962	*****	
2042	2042E	Tank 2042	1962	*****	
2043	2043E	Tank 2043	1962	*****	
2044	2044E	Tank 2044	1962	*****	
2045	2045E	Tank 2045	1962	*****	
2046	2046E	Tank 2046	1962	*****	
2047	2047E	Tank 2047	1962	*****	
2048	2048E	Tank 2048	1962	*****	
2049	2049E	Tank 2049 (out of service)	1962	*****	
2050	2050E	Tank 2050	1966	*****	
2051A	2051AE	Tank 2051A	1967	*****	
2051B	2051BE	Tank 2051B (out of service)	1967	*****	
2052	2052E	Tank 2052	1962	*****	
2053	2053E	Tank 2053	1962	*****	
2054	2054E	Tank 2054	1962	*****	
2055	2055E	Tank 2055	1962	*****	
2056	2056E	Tank 2056	1962	*****	
2057	2057E	Tank 2057	1962	*****	
2058	2058E	Tank 2058	1962	*****	
2059	2059E	Tank 2059	1962	*****	
2060	2060E	Tank 2060	1962	*****	
2061	2061E	Tank 2061	1975	*****	
2062	2062E	Tank 2062	1962	*****	
2063	2063E	Tank 2063	1962	*****	
2064	2064E	Tank 2064	1962	*****	
2065	2065E	Tank 2065	1962	*****	
2066	2066E	Tank 2066	1962	*****	

Emission Unit ID	Emission Point ID	Emission Unit Description	Year Installed	Design Capacity	Control Device
9000	9000E	Tank 9000 located at NCDT(out of service)	1956	*****	
SL-01	SL-01E	Vessel SL-01/ confidential	Nap	Nap	
SL-02	SL-02E	Vessel SL-02/ confidential	Nap	Nap	
SL-03	SL-03E	Vessel SL-03/ confidential	Nap	Nap	
D-104	D-104E	Vessel D-104E/ confidential	Nap	Nap	
L050TT	TT050L	In Unit Tank Truck Rack	Nap	Nap	
L050RC	RC050L	In Unit Rail Car Rack	Nap	Nap	
L050DR	DR050L	In Unit Drum Loading	Nap	Nap	
Specialty Surfactants (TRITON)					
8101	E-1081-2	Vessel 8101/Refining Still	1977	*****	
8310	E-1081-3	Tank 8310	1992	*****	C-8110
8313	T8313	Tank 8313	1959	*****	
8314	T8314	Tank 8314	1959	*****	
8320	T8320	Tank 8320	1959	*****	
8321	T8321	Tank 8321	1944	*****	
8322	T8322	Tank 8322	1944	*****	
8323	T8323	Tank 8323	1959	*****	
8324	T8324	Tank 8324	1959	*****	
8330	T8330	Tank 8330	1976	*****	
8331	T8331	Tank 8331	1976	*****	
8332	T8332	Tank 8332	1976	*****	
8333	T8333	Tank 8333	1959	*****	
8334	T8334	Tank 8334	1959	*****	
8340	E-1081-3	Tank 8340	1944	*****	C-8110 and C-8130
8341	T8341	Tank 8341	1944	*****	
8343	T8343	Tank 8343	1959	*****	
8344	T8344	Tank 8344	1959	*****	
8345	T8345	Tank 8345 (out of service)	1959	*****	
8346	T8346	Tank 8346 (out of service)	1959	*****	
8350	T8350	Tank 8350	1944	*****	
8351	T8351	Tank 8351	1944	*****	
8352	T8352	Tank 8352	1945	*****	
8353	E-1081-3	Tank 8353	1959	*****	C-8130
8354	T8354	Tank 8354	1959	*****	
8355	T8355	Tank 8355(out of service)	1959	*****	
8356	T8356	Tank 8356(out of service)	1959	*****	
8360	T8360	Tank 8360	1962	*****	
8361	T8361	Tank 8361	1944	*****	
8362	T8362	Tank 8362	1942	*****	
8363	E-1081-3	Tank 8363	1959	*****	C-8130
8364	T8364	Tank 8364	1959	*****	
8365	T8365	Tank 8365(out of service)	1959	*****	

Emission Unit ID	Emission Point ID	Emission Unit Description	Year Installed	Design Capacity	Control Device
8366	T8366	Tank 8366(out of service)	1959	*****	
8370	E-1081-3	Tank 8370	1975	*****	
8371	T8371	Tank 8371	1976	*****	
8372	T8372	Tank 8372 (sulfuric acid)	1948	*****	
8373	T8373	Tank 8373	1952	*****	
8375	T8375	Tank 8375(out of service)	1959	*****	
8376	T8376	Tank 8376(out of service)	1959	*****	
8380	T8380	Tank 8380	1976	*****	
8381	T8381	Tank 8381	1976	*****	
8382	E-1081-3	Tank 8382	1993	*****	C-8130
8383	T8383	Tank 8383	1952	*****	
8390	T8390	Tank 8390	1976	*****	
8391	T8391	Tank 8391	1976	*****	
8392	T8392	Tank 8392	1977	*****	
8393	T8393	Tank 8393	1952	*****	
8400	E-1084-1 or E-1084-2 or E-1081-3	8400 Reactor	1976	*****	C-8110 or none
8415	E-1084-2	Triad Hotwell	NA	NA	
8420	T8420	Tank 8420	1976	*****	
8433	T8433	Tank 8433	1993	*****	
8435	T8345	Tank 8345	1993	*****	
8500	E-1085-1 or E-1085-2 or E-1081-3	8500 Reactor	1976	*****	C-8110 or C- 8130 or none
8515	E-1085-2	LCAP Hotwell	Not applicable	Nap	
8518	None	East Filter Press	1993	*****	
8520	E-1085-4 (shared with 8835)	Tank 8520 (out of service)	1993	*****	
8528	E-1081-3	Tank 8528	1975	*****	C-8110
8540	E-1081-3	Tank 8540	1994	*****	C-8110
8600	E-1081-3 or E-1084-2 or E-1086-1	8600 Reactor	1976	*****	C-8130 or none
	Fugitive	Hopper 8629 for 8600 Reactor	Not applicable	Nap	
8617	E-1081-3 or E-1084-2 or E-1086-3	8617 Reactor	1976	*****	C-8130 or none
8621	E-1081-3	Tank 8621	1976	*****	C-8130
8636	E-1086-7	Glycol System C-8636	1975	Nap	
8706	T8706	Tank 8706 (out of service)	1993	*****	
8750	T8750	Tank 8750	1993	*****	
8738	T8738	Tank 8738	NA	NA	

Emission Unit ID	Emission Point ID	Emission Unit Description	Year Installed	Design Capacity	Control Device
	Fugitive	Process Funnel for Tank 8738	NA	NA	
8800	E-1088-1 or E-1084-2 or E-1081-3	8800 Reactor	1976	*****	
8817	T-8817	Tank 8817	1976	*****	
8820	None	West Filter Press	1993	*****	
	Fugitive	Hopper 8826 for 8800 Reactor	NA		
8835	E-1085-4 (shared with 8520)	Tank 8835 (out of service)	1993	*****	
	Fugitive	Funnel for Tank 8835	Not applicable	Nap	
C8110	E-1081-3	Caustic Scrubber	1976	Nap	C-8130
C8130	E-1081-3	Water Scrubber	1976	Nap	
C8105	E-1081-02	Condenser	Not Applicable	Nap	
L1001	L1001	Loading Rack L1001	Not applicable	Nap	
L1002	L1002	Loading Rack L1002	Not applicable	Nap	
L1003	L1003	Loading Rack L1003	Not applicable	Nap	
L1004	L1004	Loading Rack L1004	Not applicable	Nap	
L1005	L1005	Loading Rack L1005 (not located within TRITON plant)	Not applicable	Nap	
TR020		GR-7M Decant Wastewater Stream			Group 1 MON
Environmental Operations					
DP01	DP01E	Diesel Firewater Em. Pump	380 hp	Prior to 2002	
DP02	DP02E	Diesel Firewater Em. Pump	380 hp	Prior to 2002	
DP03	DP03E	Diesel Firewater Em. Pump	560 hp	Prior to 2002	
T01	T01E	Tank 01 (Sulfuric Acid)	Nap	Nap	
T02	Not applicable	Tank 2702 – No regulated pollutants (Water Treatment Additive)	Nap	Nap	
T04	Not applicable	T04 – No regulated pollutants (50% Caustic)	Nap	Nap	
T06	Nap	T06 – No regulated pollutants (25% Caustic)	Nap	Nap	
T2702	Nap	Tank 2702 - No regulated pollutants (Water Treatment Additive)	Nap	Nap	

Emission Unit ID	Emission Point ID	Emission Unit Description	Year Installed	Design Capacity	Control Device
T891047	Nap	Tank 891047 - No regulated pollutants (Water Treatment Additive)	Nap	Nap	
T891048	Nap	Tank 891048 - No regulated pollutants (Water Treatment Additive)	Nap	Nap	
T891049	Nap	Tank 891049 - No regulated pollutants (Water Treatment Additive)	Nap	Nap	
T891050	Nap	Tank 891050 No regulated pollutants (Water Treatment Additive)	Nap	Nap	
Nap	Nap	Salt Brine Tank – No regulated pollutant	Nap	Nap	
Nap	Nap	Salt Brine Dissolver – No regulated pollutants	Nap	Nap	
Nap	Nap	Deminerlizer Beds – No regulated pollutants	Nap	Nap	
Nap	Nap	Softeners – No regulated pollutants	Nap	Nap	
Nap	Nap	Accelerators/Clarifiers – No regulated pollutants	Nap	Nap	
Maintenance / Paint Shop & North Charleston Distribution (NCDT)					
9000	T9000 or 9000E	Tank 9000 ***** (out of service)	1956	*****	
T-1490	E012	Gasoline Storage Tank (out of service)	1974	*****	
T-2206	E014	Diesel Storage Tank (out of service)	1974	*****	
B-307 Paint Booths	Nap	Building 307 Paint Booths for Small Parts	Nap	Nap	
B-307 Weld Shop	Nap	Building 307 Welding Shop	Nap	Nap	
Metal Solvent Cleaning Baths	Nap	Building 307 and miscellaneous locations	Nap	Nap	
Remediation Operations					
CLBVE	SVE1	Vapor Extraction System - Chlorobenzene Area	2014	600 scfm	A42INC & A42PBS

Emission Unit ID	Emission Point ID	Emission Unit Description	Year Installed	Design Capacity	Control Device
	SVE2 (Vents to Atmosphere)	Vapor Extraction System – Chlorobenzene Area (Alternative Operating Scenario)	2019	600 scfm	None
A42VE	SVE1	Vapor Extractive System-Chlorohydrin Area (Area 42)	2011	1,050 scfm	A42INC & A42PBS
A42INC	SVE1	Regenerative Thermal Oxidizer (Incinerator)	2011	NA	A42PBS
A42PBS	SVE1	Packed Bed Caustic Scrubber	2011	NA	APCD
MI2VE	MI2VE2	Vapor Extraction System	2014	1,000 scfm	Catalytic Oxidizer MI2CO
MIGCS	MIGCS1/ MIGCS2	MI Groundwater Containment System	2017	100 gpm	MIGCS CO/MIGCS GAC
MIGCS GAC	MIGCS2	Granular Activated Carbon (GAC)	2018	500 scfm	None
MIGCS CO	MIGCS1	Anguil Model OA10 (Electric Catalytic Oxidizer)(CATOX)	2017	1,000 scfm	None
CLB2VE	SVE3	Vapor Extraction System – Chlorobenzene Area 2	2022	908 scfm	CLB2VGAC

1.2 Active R13, R14, and R19 Permits

The underlying authority for any conditions from R13, R14, and/or R19 permits contained in this operating permit is cited using the original permit number (e.g. R13-1234). The current applicable version of such permit(s) is listed below.

Permit Number	Date of Issuance
R13-1517E (TRITON® Plant)	09/21/2023
R13-2033D (Boiler 26)	04/03/2013
R13-2141C (Boiler 27)	04/19/2004
R13-2414C	08/08/2011
R13-2840F	12/20/2022
R13-3025B	05/26/2015
R13-3308B	01/02/2019

2.0 General Conditions

2.1 Definitions

- 2.1.1. All references to the "West Virginia Air Pollution Control Act" or the "Air Pollution Control Act" mean those provisions contained in W.Va. Code §§ 22-5-1 to 22-5-18.
- 2.1.2. The "Clean Air Act" means those provisions contained in 42 U.S.C. §§ 7401 to 7671q, and regulations promulgated thereunder.
- 2.1.3. "Secretary" means the Secretary of the Department of Environmental Protection or other person to whom the Secretary has delegated authority or duties pursuant to W.Va. Code §§ 22-1-6 or 22-1-8 (45CSR§30-2.39.). The Director of the Division of Air Quality is the Secretary's designated representative for the purposes of this permit.
- 2.1.4. Unless otherwise specified in a permit condition or underlying rule or regulation, all references to a "rolling yearly total" shall mean the sum of the monthly data, values or parameters being measured, monitored, or recorded, at any given time for the previous twelve (12) consecutive calendar months.

2.2 Acronyms

CAAA	Clean Air Act Amendments	NSPS	New Source Performance Standards
CBI	Confidential Business Information	PM	Particulate Matter
CEM	Continuous Emission Monitor	PM₁₀	Particulate Matter less than 10µm in diameter
CES	Certified Emission Statement	pph	Pounds per Hour
C.F.R. or CFR	Code of Federal Regulations	ppm	Parts per Million
CO	Carbon Monoxide	PSD	Prevention of Significant Deterioration
C.S.R. or CSR	Codes of State Rules	psi	Pounds per Square Inch
DAQ	Division of Air Quality	SIC	Standard Industrial Classification
DEP	Department of Environmental Protection	SIP	State Implementation Plan
FOIA	Freedom of Information Act	SO₂	Sulfur Dioxide
HAP	Hazardous Air Pollutant	TAP	Toxic Air Pollutant
HON	Hazardous Organic NESHAP	TPY	Tons per Year
HP	Horsepower	TRS	Total Reduced Sulfur
lbs/hr or lb/hr	Pounds per Hour	TSP	Total Suspended Particulate
LDAR	Leak Detection and Repair	USEPA	United States Environmental Protection Agency
m	Thousand	UTM	Universal Transverse Mercator
MACT	Maximum Achievable Control Technology	VEE	Visual Emissions Evaluation
mm	Million	VOC	Volatile Organic Compounds
mmBtu/hr	Million British Thermal Units per Hour		
mmft³/hr or mmcf/hr	Million Cubic Feet Burned per Hour		
NA or N/A	Not Applicable		
NAAQS	National Ambient Air Quality Standards		
NESHAPS	National Emissions Standards for Hazardous Air Pollutants		
NO_x	Nitrogen Oxides		

2.3. Permit Expiration and Renewal

- 2.3.1. Permit duration. This permit is issued for a fixed term of five (5) years and shall expire on the date specified on the cover of this permit, except as provided in 45CSR§30-6.3.b. and 45CSR§30-6.3.c.
[45CSR§30-5.1.b.]
- 2.3.2. A permit renewal application is timely if it is submitted at least six (6) months prior to the date of permit expiration.
[45CSR§30-4.1.a.3.]
- 2.3.3. Permit expiration terminates the source's right to operate unless a timely and complete renewal application has been submitted consistent with 45CSR§30-6.2. and 45CSR§30-4.1.a.3.
[45CSR§30-6.3.b.]
- 2.3.4. If the Secretary fails to take final action to deny or approve a timely and complete permit application before the end of the term of the previous permit, the permit shall not expire until the renewal permit has been issued or denied, and any permit shield granted for the permit shall continue in effect during that time.
[45CSR§30-6.3.c.]

2.4. Permit Actions

- 2.4.1. This permit may be modified, revoked, reopened and reissued, or terminated for cause. The filing of a request by the permittee for a permit modification, revocation and reissuance, or termination, or of a notification of planned changes or anticipated noncompliance does not stay any permit condition.
[45CSR§30-5.1.f.3.]

2.5. Reopening for Cause

- 2.5.1. This permit shall be reopened and revised under any of the following circumstances:
- a. Additional applicable requirements under the Clean Air Act or the Secretary's legislative rules become applicable to a major source with a remaining permit term of three (3) or more years. Such a reopening shall be completed no later than eighteen (18) months after promulgation of the applicable requirement. No such reopening is required if the effective date of the requirement is later than the date on which the permit is due to expire, unless the original permit or any of its terms and conditions has been extended pursuant to 45CSR§§30-6.6.a.1.A. or B.
 - b. Additional requirements (including excess emissions requirements) become applicable to an affected source under Title IV of the Clean Air Act (Acid Deposition Control) or other legislative rules of the Secretary. Upon approval by U.S. EPA, excess emissions offset plans shall be incorporated into the permit.
 - c. The Secretary or U.S. EPA determines that the permit contains a material mistake or that inaccurate statements were made in establishing the emissions standards or other terms or conditions of the permit.
 - d. The Secretary or U.S. EPA determines that the permit must be revised or revoked and reissued to assure compliance with the applicable requirements.
[45CSR§30-6.6.a.]

2.6. Administrative Permit Amendments

- 2.6.1. The permittee may request an administrative permit amendment as defined in and according to the procedures specified in 45CSR§30-6.4.
[45CSR§30-6.4.]

2.7. Minor Permit Modifications

- 2.7.1. The permittee may request a minor permit modification as defined in and according to the procedures specified in 45CSR§30-6.5.a.
[45CSR§30-6.5.a.]

2.8. Significant Permit Modification

- 2.8.1. The permittee may request a significant permit modification, in accordance with 45CSR§30-6.5.b., for permit modifications that do not qualify for minor permit modifications or as administrative amendments.
[45CSR§30-6.5.b.]

2.9. Emissions Trading

- 2.9.1. No permit revision shall be required, under any approved economic incentives, marketable permits, emissions trading, and other similar programs or processes for changes that are provided for in the permit and that are in accordance with all applicable requirements.
[45CSR§30-5.1.h.]

2.10. Off-Permit Changes

- 2.10.1. Except as provided below, a facility may make any change in its operations or emissions that is not addressed nor prohibited in its permit and which is not considered to be construction nor modification under any rule promulgated by the Secretary without obtaining an amendment or modification of its permit. Such changes shall be subject to the following requirements and restrictions:
- a. The change must meet all applicable requirements and may not violate any existing permit term or condition.
 - b. The permittee must provide a written notice of the change to the Secretary and to U.S. EPA within two (2) business days following the date of the change. Such written notice shall describe each such change, including the date, any change in emissions, pollutants emitted, and any applicable requirement that would apply as a result of the change.
 - c. The change shall not qualify for the permit shield.
 - d. The permittee shall keep records describing all changes made at the source that result in emissions of regulated air pollutants, but not otherwise regulated under the permit, and the emissions resulting from those changes.
 - e. No permittee may make any change subject to any requirement under Title IV of the Clean Air Act (Acid Deposition Control) pursuant to the provisions of 45CSR§30-5.9.

- f. No permittee may make any changes which would require preconstruction review under any provision of Title I of the Clean Air Act (including 45CSR14 and 45CSR19) pursuant to the provisions of 45CSR§30-5.9.

[45CSR§30-5.9.]

2.11. Operational Flexibility

- 2.11.1. The permittee may make changes within the facility as provided by § 502(b)(10) of the Clean Air Act. Such operational flexibility shall be provided in the permit in conformance with the permit application and applicable requirements. No such changes shall be a modification under any rule or any provision of Title I of the Clean Air Act (including 45CSR14 and 45CSR19) promulgated by the Secretary in accordance with Title I of the Clean Air Act and the change shall not result in a level of emissions exceeding the emissions allowable under the permit.

[45CSR§30-5.8]

- 2.11.2. Before making a change under 45CSR§30-5.8., the permittee shall provide advance written notice to the Secretary and to U.S. EPA, describing the change to be made, the date on which the change will occur, any changes in emissions, and any permit terms and conditions that are affected. The permittee shall thereafter maintain a copy of the notice with the permit, and the Secretary shall place a copy with the permit in the public file. The written notice shall be provided to the Secretary and U.S. EPA at least seven (7) days prior to the date that the change is to be made, except that this period may be shortened or eliminated as necessary for a change that must be implemented more quickly to address unanticipated conditions posing a significant health, safety, or environmental hazard. If less than seven (7) days' notice is provided because of a need to respond more quickly to such unanticipated conditions, the permittee shall provide notice to the Secretary and U.S. EPA as soon as possible after learning of the need to make the change.

[45CSR§30-5.8.a.]

- 2.11.3. The permit shield shall not apply to changes made under 45CSR§30-5.8., except those provided for in 45CSR§30-5.8.d. However, the protection of the permit shield will continue to apply to operations and emissions that are not affected by the change, provided that the permittee complies with the terms and conditions of the permit applicable to such operations and emissions. The permit shield may be reinstated for emissions and operations affected by the change:

- a. If subsequent changes cause the facility's operations and emissions to revert to those authorized in the permit and the permittee resumes compliance with the terms and conditions of the permit, or
- b. If the permittee obtains final approval of a significant modification to the permit to incorporate the change in the permit.

[45CSR§30-5.8.c.]

- 2.11.4. "Section 502(b)(10) changes" are changes that contravene an express permit term. Such changes do not include changes that would violate applicable requirements or contravene enforceable permit terms and conditions that are monitoring (including test methods), recordkeeping, reporting, or compliance certification requirements.

[45CSR§30-2.40]

2.12. Reasonably Anticipated Operating Scenarios

2.12.1. The following are terms and conditions for reasonably anticipated operating scenarios identified in this permit.

- a. Contemporaneously with making a change from one operating scenario to another, the permittee shall record in a log at the permitted facility a record of the scenario under which it is operating and to document the change in reports submitted pursuant to the terms of this permit and 45CSR30.
- b. The permit shield shall extend to all terms and conditions under each such operating scenario; and
- c. The terms and conditions of each such alternative scenario shall meet all applicable requirements and the requirements of 45CSR30.

[45CSR§30-5.1.i.]

2.13. Duty to Comply

2.13.1. The permittee must comply with all conditions of this permit. Any permit noncompliance constitutes a violation of the West Virginia Code and the Clean Air Act and is grounds for enforcement action by the Secretary or USEPA; for permit termination, revocation and reissuance, or modification; or for denial of a permit renewal application.

[45CSR§30-5.1.f.1.]

2.14. Inspection and Entry

2.14.1. The permittee shall allow any authorized representative of the Secretary, upon the presentation of credentials and other documents as may be required by law, to perform the following:

- a. At all reasonable times (including all times in which the facility is in operation) enter upon the permittee's premises where a source is located or emissions related activity is conducted, or where records must be kept under the conditions of this permit;
- b. Have access to and copy, at reasonable times, any records that must be kept under the conditions of this permit;
- c. Inspect at reasonable times (including all times in which the facility is in operation) any facilities, equipment (including monitoring and air pollution Control equipment), practices, or operations regulated or required under the permit;
- d. Sample or monitor at reasonable times substances or parameters to determine compliance with the permit or applicable requirements or ascertain the amounts and types of air pollutants discharged.

[45CSR§30-5.3.b.]

2.15. Schedule of Compliance

- 2.15.1. For sources subject to a compliance schedule, certified progress reports shall be submitted consistent with the applicable schedule of compliance set forth in this permit and 45CSR§30-4.3.h., but at least every six (6) months, and no greater than once a month, and shall include the following:
- a. Dates for achieving the activities, milestones, or compliance required in the schedule of compliance, and dates when such activities, milestones or compliance were achieved; and
 - b. An explanation of why any dates in the schedule of compliance were not or will not be met, and any preventative or corrective measure adopted.

[45CSR§30-5.3.d.]

2.16. Need to Halt or Reduce Activity not a Defense

- 2.16.1. It shall not be a defense for a permittee in an enforcement action that it would have been necessary to halt or reduce the permitted activity in order to maintain compliance with the conditions of this permit. However, nothing in this paragraph shall be construed as precluding consideration of a need to halt or reduce activity as a mitigating factor in determining penalties for noncompliance if the health, safety, or environmental impacts of halting or reducing operations would be more serious than the impacts of continued operations.

[45CSR§30-5.1.f.2.]

2.17. Reserved

2.18. Federally-Enforceable Requirements

- 2.18.1. All terms and conditions in this permit, including any provisions designed to limit a source's potential to emit and excepting those provisions that are specifically designated in the permit as "State-enforceable only", are enforceable by the Secretary, USEPA, and citizens under the Clean Air Act.

[45CSR§30-5.2.a.]

- 2.18.2. Those provisions specifically designated in the permit as "State-enforceable only" shall become "Federally-enforceable" requirements upon SIP approval by the USEPA.

2.19. Duty to Provide Information

- 2.19.1. The permittee shall furnish to the Secretary within a reasonable time any information the Secretary may request in writing to determine whether cause exists for modifying, revoking and reissuing, or terminating the permit or to determine compliance with the permit. Upon request, the permittee shall also furnish to the Secretary copies of records required to be kept by the permittee. For information claimed to be confidential, the permittee shall furnish such records to the Secretary along with a claim of confidentiality in accordance with 45CSR31. If confidential information is to be sent to USEPA, the permittee shall directly provide such information to USEPA along with a claim of confidentiality in accordance with 40 C.F.R. Part 2.

[45CSR§30-5.1.f.5.]

2.20. Duty to Supplement and Correct Information

- 2.20.1. Upon becoming aware of a failure to submit any relevant facts or a submittal of incorrect information in any permit application, the permittee shall promptly submit to the Secretary such supplemental facts or corrected information.

[45CSR§30-4.2.]

2.21. Permit Shield

- 2.21.1. Compliance with the conditions of this permit shall be deemed compliance with any applicable requirements as of the date of permit issuance provided that such applicable requirements are included and are specifically identified in this permit or the Secretary has determined that other requirements specifically identified are not applicable to the source and this permit includes such a determination or a concise summary thereof.

[45CSR§30-5.6.a.]

- 2.21.2. Nothing in this permit shall alter or affect the following:

- a. The liability of an owner or operator of a source for any violation of applicable requirements prior to or at the time of permit issuance; or
- b. The applicable requirements of the Code of West Virginia and Title IV of the Clean Air Act (Acid Deposition Control), consistent with § 408 (a) of the Clean Air Act.
- c. The authority of the Administrator of U.S. EPA to require information under § 114 of the Clean Air Act or to issue emergency orders under § 303 of the Clean Air Act.

[45CSR§30-5.6.c.]

2.22. Credible Evidence

- 2.22.1. Nothing in this permit shall alter or affect the ability of any person to establish compliance with, or a violation of, any applicable requirement through the use of credible evidence to the extent authorized by law. Nothing in this permit shall be construed to waive any defenses otherwise available to the permittee including but not limited to any challenge to the credible evidence rule in the context of any future proceeding.

[45CSR§30-5.3.e.3.B.]

2.23. Severability

- 2.23.1. The provisions of this permit are severable. If any provision of this permit, or the application of any provision of this permit to any circumstance is held invalid by a court of competent jurisdiction, the remaining permit terms and conditions or their application to other circumstances shall remain in full force and effect.

[45CSR§30-5.1.e.]

2.24. Property Rights

- 2.24.1. This permit does not convey any property rights of any sort or any exclusive privilege.

[45CSR§30-5.1.f.4]

2.25. Acid Deposition Control

- 2.25.1. Emissions shall not exceed any allowances that the source lawfully holds under Title IV of the Clean Air Act (Acid Deposition Control) or rules of the Secretary promulgated thereunder.
- a. No permit revision shall be required for increases in emissions that are authorized by allowances acquired pursuant to the acid deposition control program, provided that such increases do not require a permit revision under any other applicable requirement.
 - b. No limit shall be placed on the number of allowances held by the source. The source may not, however, use allowances as a defense to noncompliance with any other applicable requirement.
 - c. Any such allowance shall be accounted for according to the procedures established in rules promulgated under Title IV of the Clean Air Act.

[45CSR§30-5.1.d.]

- 2.25.2. Where applicable requirements of the Clean Air Act are more stringent than any applicable requirement of regulations promulgated under Title IV of the Clean Air Act (Acid Deposition Control), both provisions shall be incorporated into the permit and shall be enforceable by the Secretary and U. S. EPA.

[45CSR§30-5.1.a.2.]

3.0 Facility-Wide Requirements

3.1 Limitations and Standards

- 3.1.1. **Open burning.** The open burning of refuse by any person is prohibited except as noted in 45CSR§6-3.1.
[45CSR§6-3.1.]
- 3.1.2. **Open burning exemptions.** The exemptions listed in 45CSR§6-3.1 are subject to the following stipulation: Upon notification by the Secretary, no person shall cause or allow any form of open burning during existing or predicted periods of atmospheric stagnation. Notification shall be made by such means as the Secretary may deem necessary and feasible.
[45CSR§6-3.2.]
- 3.1.3. **Asbestos.** The permittee is responsible for thoroughly inspecting the facility, or part of the facility, prior to commencement of demolition or renovation for the presence of asbestos and complying with 40 C.F.R. § 61.145, 40 C.F.R. § 61.148, and 40 C.F.R. § 61.150. The permittee, owner, or operator must notify the Secretary at least ten (10) working days prior to the commencement of any asbestos removal on the forms prescribed by the Secretary if the permittee is subject to the notification requirements of 40 C.F.R. § 61.145(b)(3)(i). The USEPA, the Division of Waste Management and the Bureau for Public Health - Environmental Health require a copy of this notice to be sent to them.
[40 C.F.R. §61.145(b) and 45CSR34]
- 3.1.4. **Odor.** No person shall cause, suffer, allow or permit the discharge of air pollutants which cause or contribute to an objectionable odor at any location occupied by the public.
[45CSR§4-3.1 State-Enforceable only.]
- 3.1.5. **Standby plan for reducing emissions.** When requested by the Secretary, the permittee shall prepare standby plans for reducing the emissions of air pollutants in accordance with the objectives set forth in Tables I, II, and III of 45CSR11.
[45CSR§11-5.2]
- 3.1.6. **Emission inventory.** The permittee is responsible for submitting, on an annual basis, an emission inventory in accordance with the submittal requirements of the Division of Air Quality.
[W.Va. Code § 22-5-4(a)(14)]
- 3.1.7. **Ozone-depleting substances.** For those facilities performing maintenance, service, repair or disposal of appliances, the permittee shall comply with the standards for recycling and emissions reduction pursuant to 40 C.F.R. Part 82, Subpart F, except as provided for Motor Vehicle Air Conditioners (MVACs) in Subpart B:
- a. Persons opening appliances for maintenance, service, repair, or disposal must comply with the prohibitions and required practices pursuant to 40 C.F.R. §§ 82.154 and 82.156.
 - b. Equipment used during the maintenance, service, repair, or disposal of appliances must comply with the standards for recycling and recovery equipment pursuant to 40 C.F.R. § 82.158.
 - c. Persons performing maintenance, service, repair, or disposal of appliances must be certified by an approved technician certification program pursuant to 40 C.F.R. § 82.161.
- [40 C.F.R. 82, Subpart F]

- 3.1.8. **Risk Management Plan.** This stationary source, as defined in 40 C.F.R. § 68.3, is subject to Part 68. The owner or operator shall submit a risk management plan (RMP) by the date specified in 40 C.F.R. § 68.10 and shall certify compliance with the requirements of Part 68 as part of the annual compliance certification as required by 40 C.F.R. Part 70 or 71. **[40 C.F.R. 68]**
- 3.1.9. Reserved.
- 3.1.10. **Ozone Season NOx Emission Limitation.** The owner or operator of a unit that has a maximum design heat input greater than 250 mmBtu/hr, except for any unit subject to the federal Cross-State Air Pollution Rule (CSAPR) NOx Ozone Season Group 2 Trading Program established under 40CFR Part 97, Subpart EEEEE, or an equivalent trading program established under 45CSR43 and approved as a state implementation plan revision pursuant to 40CFR§52.38(b)(9), shall comply with the ozone season NOx emission limitation, and monitoring, recordkeeping and reporting requirements for ozone season emissions of NOx set forth in 45CSR§40-5.1 and 45CSR§40-6.1. **[45CSR§40-4.1]**
- a. Beginning May 1, 2016, the owner or operator of a unit that meets the applicability requirements set forth in 45CSR§40-4.1 shall limit emissions of NOx during an ozone season pursuant to a NOx emission rate for each unit contained in a permit issued under 45CSR13, 45CSR14, 45CSR19 or via consent order issued by the Secretary in accordance with W.Va. Code §22-5-4(a)(5). Such ozone season NOx limitation may also include a limitation on operating time for a unit during the ozone season. **[45CSR§40-5.1.]**
- b. The owner or operator of an applicable unit under 45CSR§40-4.1 shall operate certified continuous emission monitor systems necessary to attribute ozone season NOx mass emissions to each unit, in accordance with 40CFR Part 75, Subpart H. NOx mass emission measurements recorded and reported in accordance with 40CFR Part 75, Subpart H shall be used to determine a unit's compliance with the ozone season NOx emission limitation set forth in 3.1.10.a. **[45CSR§40-6.1.]**

3.2. Monitoring Requirements

- 3.2.1. N/A

3.3. Testing Requirements

- 3.3.1. **Stack testing.** As per provisions set forth in this permit or as otherwise required by the Secretary, in accordance with the West Virginia Code, underlying regulations, permits and orders, the permittee shall conduct test(s) to determine compliance with the emission limitations set forth in this permit and/or established or set forth in underlying documents. The Secretary, or his duly authorized representative, may at his option witness or conduct such test(s). Should the Secretary exercise his option to conduct such test(s), the operator shall provide all necessary sampling connections and sampling ports to be located in such manner as the Secretary may require, power for test equipment and the required safety equipment, such as scaffolding, railings and ladders, to comply with generally accepted good safety practices. Such tests shall be conducted in accordance with the methods and procedures set forth in this permit or as otherwise approved or specified by the Secretary in accordance with the following:
- a. The Secretary may on a source-specific basis approve or specify additional testing or alternative testing to the test methods specified in the permit for demonstrating compliance with 40 C.F.R. Parts 60, 61, and 63, if applicable, in accordance with the Secretary's delegated authority and any established equivalency determination methods which are applicable.

- b. The Secretary may on a source-specific basis approve or specify additional testing or alternative testing to the test methods specified in the permit for demonstrating compliance with applicable requirements which do not involve federal delegation. In specifying or approving such alternative testing to the test methods, the Secretary, to the extent possible, shall utilize the same equivalency criteria as would be used in approving such changes under Section 3.3.1.a. of this permit.
- c. All periodic tests to determine mass emission limits from or air pollutant concentrations in discharge stacks and such other tests as specified in this permit shall be conducted in accordance with an approved test protocol. Unless previously approved, such protocols shall be submitted to the Secretary in writing at least thirty (30) days prior to any testing and shall contain the information set forth by the Secretary. In addition, the permittee shall notify the Secretary at least fifteen (15) days prior to any testing so the Secretary may have the opportunity to observe such tests. This notification shall include the actual date and time during which the test will be conducted and, if appropriate, verification that the tests will fully conform to a referenced protocol previously approved by the Secretary.
- d. The permittee shall submit a report of the results of the stack test within 60 days of completion of the test. The test report shall provide the information necessary to document the objectives of the test and to determine whether proper procedures were used to accomplish these objectives. The report shall include the following: the certification described in paragraph 3.5.1; a statement of compliance status, also signed by a responsible official; and, a summary of conditions which form the basis for the compliance status evaluation. The summary of conditions shall include the following:
 1. The permit or rule evaluated, with the citation number and language.
 2. The result of the test for each permit or rule condition.
 3. A statement of compliance or non-compliance with each permit or rule condition.

[WV Code §§ 22-5-4(a)(14-15) and 45CSR13]

3.4. Recordkeeping Requirements

- 3.4.1. **Monitoring information.** The permittee shall keep records of monitoring information that include the following:
 - a. The date, place as defined in this permit and time of sampling or measurements;
 - b. The date(s) analyses were performed;
 - c. The company or entity that performed the analyses;
 - d. The analytical techniques or methods used;
 - e. The results of the analyses; and
 - f. The operating conditions existing at the time of sampling or measurement.

[45CSR§30-5.1.c.2.A., 45CSR13, Permit Number R13-2033, Condition 4.2.1; R13-2840, Condition 4.3.1; R13-2414, Condition 4.4.1, 45CSR13, Permit Number R13-3308, Condition 4.4.1]

- 3.4.2. **Retention of records.** The permittee shall retain records of all required monitoring data and support information for a period of at least five (5) years from the date of monitoring sample, measurement, report, application, or record creation date. Support information includes all calibration and maintenance records and all original strip-chart recordings for continuous monitoring instrumentation, and copies of all reports required by the permit. Where appropriate, records may be maintained in computerized form in lieu of the above records.

[45CSR§30-5.1.c.2.B.]

- 3.4.3. **Odors.** For the purposes of 45CSR4, the permittee shall maintain a record of all odor complaints received, any investigation performed in response to such a complaint, and any responsive action(s) taken.
[45CSR§30-5.1.c. State-Enforceable only.]

3.5. Reporting Requirements

- 3.5.1. **Responsible official.** Any application form, report, or compliance certification required by this permit to be submitted to the DAQ and/or USEPA shall contain a certification by the responsible official that states that, based on information and belief formed after reasonable inquiry, the statements and information in the document are true, accurate and complete.
[45CSR§§30-4.4. and 5.1.c.3.D.]
- 3.5.2. A permittee may request confidential treatment for the submission of reporting required under 45CSR§30-5.1.c.3. pursuant to the limitations and procedures of W.Va. Code § 22-5-10 and 45CSR31.
[45CSR§30-5.1.c.3.E.]
- 3.5.3. Except for the electronic submittal of the annual compliance certification and semi-annual monitoring reports to the DAQ and USEPA as required in 3.5.5 and 3.5.6. below, all notices, requests, demands, submissions and other communications required or permitted to be made to the Secretary of DEP and/or USEPA shall be made in writing and shall be deemed to have been duly given when delivered by hand, mailed first class or by private carrier with postage prepaid to the address(es), or submitted in electronic format by e-mail as set forth below or to such other person or address as the Secretary of the Department of Environmental Protection may designate:

DAQ:

Director
WVDEP
Division of Air Quality
601 57th Street SE
Charleston, WV 25304

US EPA:

Section Chief
U.S. Environmental Protection Agency,
Region III
Enforcement and Compliance Assurance
Division
Air, RCRA and Toxics Branch (3ED21)
Four Penn Center
1600 John F. Kennedy Boulevard
Philadelphia, PA 19103-2852

DAQ Compliance and Enforcement¹:

DEPAirQualityReports@wv.gov

¹For all self-monitoring reports (MACT, GACT, NSPS, etc.), stack tests and protocols, Notice of Compliance Status reports, Initial Notifications, etc.

- 3.5.4. **Fees.** The permittee shall pay fees on an annual basis in accordance with 45CSR§30-8.
[45CSR§30-8.]

- 3.5.5. **Compliance certification.** The permittee shall certify compliance with the conditions of this permit on the forms provided by the DAQ. In addition to the annual compliance certification, the permittee may be required to submit certifications more frequently under an applicable requirement of this permit. The annual certification shall be submitted to the DAQ and USEPA on or before March 15 of each year, and shall certify compliance for the period ending December 31. The permittee shall maintain a copy of the certification on site for (5) years from submittal of the certification. The annual certification shall be submitted in electronic format by e-mail to the following addresses:

DAQ:

DEPAirQualityReports@wv.gov

[45CSR§30-5.3.e.]

US EPA:

R3_APD_Permits@epa.gov

- 3.5.6. **Semi-annual monitoring reports.** The permittee shall submit reports of any required monitoring on or before September 15 for the reporting period January 1 to June 30 and on or before March 15 for the reporting period July 1 to December 31. All instances of deviation from permit requirements must be clearly identified in such reports. All required reports must be certified by a responsible official consistent with 45CSR§30-4.4. The semi-annual monitoring reports shall be submitted in electronic format by e-mail to the following address:

DAQ:

DEPAirQualityReports@wv.gov

[45CSR§30-5.1.c.3.A.]

- 3.5.7. **Reserved.**

- 3.5.8. **Deviations.**

- a. In addition to monitoring reports required by this permit, the permittee shall promptly submit supplemental reports and notices in accordance with the following:

1. Reserved.
2. Any deviation that poses an imminent and substantial danger to public health, safety, or the environment shall be reported to the Secretary immediately by telephone or email. A written report of such deviation, which shall include the probable cause of such deviation, and any corrective actions or preventative measures taken, shall be submitted by the responsible official within ten (10) days of the deviation.
3. Deviations for which more frequent reporting is required under this permit shall be reported on the more frequent basis.
4. All reports of deviations shall identify the probable cause of the deviation and any corrective actions or preventative measures taken.

[45CSR§30-5.1.c.3.C.]

- b. The permittee shall, in the reporting of deviations from permit requirements, including those attributable to upset conditions as defined in this permit, report the probable cause of such deviations and any corrective actions or preventative measures taken in accordance with any rules of the Secretary.

[45CSR§30-5.1.c.3.B.]

- 3.5.9. **New applicable requirements.** If any applicable requirement is promulgated during the term of this permit, the permittee will meet such requirements on a timely basis, or in accordance with a more detailed schedule if required by the applicable requirement.

[45CSR§30-4.3.h.1.B.]

3.6. Compliance Plan

- 3.6.1. N/A

3.7. Permit Shield

- 3.7.1. The permittee is hereby granted a permit shield in accordance with 45CSR§30-5.6. The permit shield applies provided the permittee operates in accordance with the information contained within this permit.

- 3.7.2. The following requirements specifically identified are not applicable to the source based on the determinations set forth below. The permit shield shall apply to the following requirements provided the conditions of the determinations are met.

45CSR7	<p>Sulfuric acid mist/vapours and Phosphoric Acid vapours Tanks used to store sulfuric acid or phosphoric acid from concentration limits. Per Section 10.6 of Regulation 7, sources with potential to emit less than 0.1 lbs/hr, 100 lbs/yr are exempt from the concentration limits of Section 4.2. The following tanks have been found to meet this criteria:</p> <p>Tank 9750 is used to store sulfuric acid at the Oxide Adducts Plant. Tank 8372 is used to store sulfuric acid at the Specialty Surfactants Plant. Tank 8433 is used to store phosphoric acid at the Specialty Surfactants Plant. Tank T01 is used to store sulfuric acid at the Water Treatment Plant.</p>
45CSR7	<p>The carpentry shops (B463) and welding shops (B307) are used for fabrication of materials to support site operations. These activities are incidental (support) operations to the South Charleston Facility and are not manufacturing processes. Carpentry and welding shop activities are not covered by 45CSR7.</p>
45CSR10A 45CSR10	<p>Testing, Monitoring, Record Keeping, and Reporting Requirements under Section 8 of 45CSR10 are not applicable to Boilers 26 and 27 since they only combust natural gas. 45CSR§10-10.3</p> <p>Boilers 26 and 27 are also exempt from the 2000 ppm SO₂ requirements of 45CSR§10-4 due to the exemption from 45CSR§10-4.1.e by having a potential of less than 500 lbs/yr SO₂ from any manufacturing processes venting to these boilers. Additionally, Boilers 26 and 27 are exempt from 45CSR§10-5 for combustion of refinery or process gases containing hydrogen sulfide in excess of 50 grains/100 ft³ due to process gas streams having no known potential for sulfur contamination.</p>

40CFR60, Subpart Kb	<p>The following tanks associated with the Oxide Adducts Plant are greater than or equal to 19,813 gallons but less than 39,890 gallons and were constructed or modified after July 23, 1984 and have a maximum true vapor pressure less than 2.2 psia: 9513.</p> <p>The following tanks associated with the Oxide Adducts Plant are greater than or equal to 39,890 gallons and were constructed or modified after July 23, 1984 and have a maximum true vapor pressure less than 0.51 psia: 9510, 9511, and 9512.</p> <p>All tanks over 19,813 gallons capacity located at the Specialty Surfactants Plant store materials with < 2.2 psia vapor pressure at storage conditions.</p>
40CFR63, Subpart Y	<p>NESHAP for Marine Vessel Loading Operations. The North Charleston Distribution Terminal is exempt from Subpart Y requirements because they no longer load barges at this location or any other location covered by this permit</p>
40CFR63, Subpart JJ	<p>Wood Furniture Surface Coating. The South Charleston Facility is an incidental manufacturer and exempt from Subpart JJ. Less than 100 gallons per month surface coating and adhesive is used for wood furniture.</p>
40CFR63, Subpart EEEE	<p>The North Charleston Distribution Terminal (NCDT) and the Chemical Mixing Unit are exempt from the OLD MACT for one or more of the following reasons: Storage vessels located at NCDT are part of processing units covered by other MACTs, or streams (materials transferred) have annual average true vapor pressure of Subpart EEEE Table 1 OHAPs at 77°F less than 0.1 psia, or streams contain less than 5% by weight of Subpart EEEE Table 1 OHAPS and are not organic liquids subject to the OLD MACT.</p> <p>The EO distribution header system does not meet the definition of an OLD MACT affected source as defined in 40 C.F.R. §63.2338(b) and is therefore not covered by 40 C.F.R. 63, Subpart EEEE.</p> <p>The Specialty Surfactants Plant is not subject to the OLD MACT. The Specialty Surfactants Plant is covered by the Polyether Polyol and Miscellaneous Organic Chemical Manufacturing MACT. Annual average vapor pressure of Table 1 OHAP at 77°F used as heat transfer liquid is less than 0.1 psia, or no streams containing greater than or equal to 5% by weight Table 1 OHAPS.</p>
40CFR63, Subpart MMMM	<p>Coating of Metal Parts. The South Charleston Facility is an incidental manufacturer and exempt from Subpart MMMM due to 40CFR§63.3881(b). This provision establishes a lower cut-off at less than 250 gallons per month of paints/solvents used.</p>

40CFR63, Subpart FFFF	The Triton unit has one reactor, which is subject to 40CFR63, Subpart PPP for polyether polyols production. As a result, reactor 8400 (Alkox Reactor) is exempt from the requirements of Subpart FFFF in accordance with §63.2435(b)(3).
-----------------------	--

4.0 Source-Specific Requirements [Energy Systems - Boiler Power House and Auxiliary Air Compressors, Emission Point ID(s) (26E, 27E, A-001, A-002, A-003, A-004)]

4.1. Limitations and Standards

4.1.1. The maximum allowable emissions from Boiler B26 through emission point 26E to the atmosphere are as follows:

Pollutant	Potential Emissions (pounds/hour)	Potential Emissions (tons/year)
Carbon Monoxide (CO)	22.5	98.4
Oxides of Nitrogen (NOx)	70.4	308.35
PM/PM10/PM2.5*	2.22	9.7
Sulfur Dioxide (SO2)	20.1	88.1
Total VOCs	24.2	13.1
Vinyl Acetate	0.82	1.1
Propylene Oxide	20	0.6
Hexane	1.4	2.8
Total HAPs	22.3	4.6
CO2e	43,370	186,301

*Includes condensables

The SO₂ limitations established by this requirement streamlines and assures compliance with the 45CSR§10-3.2.c SO₂ limit of 563.2 lb/hr. Additionally, this is also true with respect to PM emissions, as limited by 45CSR§2-4.1.b to 31.68 lb/hr PM.

[45CSR13, Permit Number R13-2033, Condition 4.1.1., Emission Point ID (26E)]

4.1.2. Boiler 26 shall only combust the following materials:

4.1.2.1 Natural gas.

4.1.2.2 Natural gas liquid condensate from boiler fuel feed piping.

4.1.2.3 Process vent gas from Covestro LLC’s propylene oxide filtering system containing water vapor, nitrogen and propylene oxide.

[45CSR13, Permit Number R13-2033, Condition 4.1.2., Emission Point ID (26E)]

4.1.3. Total heat input from all process vent gas combustion shall not exceed 10% of the total annual heat input to the boiler based on a 12-month rolling average.

[45CSR13, Permit Number R13-2033, Condition 4.1.3., Emission Point ID (26E)]

4.1.4. Reserved.

4.1.5. Boiler B26 shall not combust more than 352,000 cubic feet of natural gas per hour nor more than 3,086 MMcf per year based on a rolling 12-month total.

[45CSR13, Permit Number R13-2033, Condition 4.1.5., Emission Unit ID (B26)]

4.1.6. Boiler 26 shall not combust more than 100 gallons per hour of natural gas liquid condensate nor more than 24,700 gallons per year based on a rolling 12-month total.

[45CSR13, Permit Number R13-2033, Condition 4.1.6., Emission Unit ID (B26)]

4.1.7 Boiler 26 shall comply with all applicable emission standards of 40CFR60 Subpart Db including but not limited to the following:

4.1.7.1 NO_x emissions from Boiler 26 shall not exceed 0.2 pounds per MMBtu following commencement of burning process vent gas or natural gas condensate.
[40CFR§60.44b(1)(ii), 45CSR16]

NO_x emissions data shall be calculated and maintained using the 30-day rolling average method.
[45CSR13, Permit Number R13-2033, Condition 4.1.7., Emission Unit ID (B26)]

4.1.8 Anytime Boiler 26 or 27 is combusting process vent gas from Covestro LLC, the permittee shall comply with all applicable emission standards of 40CFR63 Subpart PPP including but not limited to the following:

4.1.8.1 Emissions of propylene oxide shall be reduced by at least 98%.
[40CFR§63.1425(b)(2), 45CSR34]

4.1.8.2 Process vent gas shall be introduced into the boiler combustion chamber.
[40CFR§63.1430(b)(2)(iii), 45CSR34]

[40CFR63, Subpart PPP, 45CSR13, Permit Number R13-2033, Condition 4.1.8., Emission Unit ID (B26, B27)]

4.1.9 Reserved.

4.1.10 Visible emissions from Boiler 26 shall not exceed 10% opacity based on a six-minute block average.
[45CSR§2-3.1., 45CSR13, Permit Number R13-2033, Condition 4.1.10., Emission Unit ID (B26)]

4.1.11 The permittee shall comply with all applicable requirements of 45CSR40 – “Control of Ozone Season Nitrogen Oxides Emissions”.
[45CSR13, Permit Number R13-2033, Condition 4.1.11., Emission Unit ID (B26)]

4.1.12. Boiler 27 shall be constructed and operated in accordance with information filed in Permit Application R13-2141A, B, and C and any amendments thereto. The Director may suspend or revoke a permit if the plans and specifications upon which the approval was based are not adhered to.
[45CSR13, Permit Number R13-2141, Condition C.3., Emission Unit ID (B27)]

4.1.13. Boiler B27 shall utilize natural gas as its fuel source, and shall be operated in a manner not to exceed the maximum design heat input of 353 million Btu per hour.
[45CSR13, Permit Number R13-2141 Condition A.1., Emission Unit ID (B27)]

4.1.14. Boiler B27 shall not consume more than 353,000 cubic feet of natural gas per hour, or approximately 3,092 million cubic feet per year. Annual fuel consumption shall be based on a 12-month rolling yearly total. A rolling yearly total shall mean the total natural gas usage at any given time for the previous twelve (12) consecutive calendar months.
[45CSR13, Permit Number R13-2141 Condition A.2., Emission Unit (B27)]

4.1.15. The process vent gases from the following plants may be drafted to B27 for the purpose of VOC reduction at a minimum control efficiency of 99 percent:

a. Covestro LLC - Propylene Oxide Filtering
[45CSR13, Permit Number R13-2141, Condition A.3., Emission Unit ID (B27)]

4.1.16. The emission of NO_x to the atmosphere from Boiler B27 (No. 27 Boiler) shall be limited to 0.2 lbs NO_x per million Btu heat input, “high heat release,” as set forth in 40CFR60 Subpart Db, Section 60.44(b). Compliance with the hourly emission limits shall be based on a 30-day rolling average in accordance to 40CFR60.46(b).
[45CSR13, Permit Number R13-2141, Condition A.5., Emission Point ID (27E)]

- 4.1.17. The maximum allowable emissions to the atmosphere from the operation of the natural gas fired Boiler B27 (No. 27 Boiler, ID: 27E) shall be limited to those pollutants and associated rates shown in Table 4.1.17.

Table 4.1.17.

Pollutant	Emission Point ID - 27E	
	Hourly Limits (lbs/hr)	Annual Limits (tons/yr)
CO	33.00	95.00
NO _x	70.60	309.00
SO ₂	0.26	1.15
PM ₁₀	5.00	14.50
VOC	30.00	29.50
Propylene Oxide	20.00	0.58
Hexane	1.25	2.75

The SO₂ limitations established by this requirement streamlines and assures compliance with the §10-3.2.c SO₂ limit of 564.8 lb/hr. Additionally, this is also true with respect to PM emissions, as limited by 45CSR§2-4.1.b to 31.77 lb/hr PM.

[45CSR13, Permit Number R13-2141, Condition A.6., Emission Point ID (27E)]

- 4.1.18. The pertinent sections of 45CSR2 applicable to this facility include, but are not limited to, the following:

§2-3.1.

No person shall cause, suffer, allow or permit emission of smoke and/or particulate matter into the open air from any fuel burning unit which is greater than ten (10) percent opacity based on a six-minute block average.

§2-4.1.

No person shall cause, suffer, allow or permit the discharge of particulate matter into the open air from all fuel burning units located at one plant, measured in terms of pounds per hour in excess of the amount determined as follows:

- b. For Type 'b' fuel burning units, the product of 0.09 and the total design heat inputs for such units in million B.T.U.'s per hour, provided however that no more than six hundred (600) pounds per hour of particulate matter shall be discharged into the open air from all such units;

§2-4.4.

The addition of sulfur oxides to a combustion unit exit gas stream for the purpose of improving emissions control equipment efficiency shall be reviewed by the Director. No person shall cause, suffer, allow or permit the addition of sulfur oxides as described above unless written approval for such addition is provided by the Director.

§2-8.1. Testing.

- a. Upon request of the Director, the owner or operator of a fuel burning unit(s) shall demonstrate compliance with of 45CSR§2-3 by periodic testing in accordance with 40CFRPart 60, Appendix A, Method 9, or a certified continuous opacity monitoring system, as approved by the Director, and of 45CSR§2-4 by periodic particulate matter stack testing, conducted in accordance with the appropriate test method set forth in the Appendix to 45CSR2 or other equivalent EPA approved method approved by the Director.

b. At such reasonable times as the Director may designate, the owner or operator of any fuel burning unit(s) may be required to conduct or have conducted tests to determine the compliance of such unit(s) with the emission limitations of 45CSR§2-4. Such tests shall be conducted in accordance with the appropriate method set forth in the Appendix to 45CSR2 or other equivalent EPA approved method approved by the Director. The Director, or his duly authorized representative, may at his option witness or conduct such tests. Should the Director exercise his option to conduct such tests, the operator will provide all necessary sampling connections and sampling ports located in such manner as the Director may require, power for test equipment, and the required safety equipment such as scaffolding, railings and ladders to comply with generally accepted good safety practices.

1. Sufficient information on temperatures, velocities, pressures, weights, and dimensional values shall be reported to the Director, with such necessary commentary as he may require, to allow an accurate evaluation of the reported test results and the conditions under which they were obtained.

c. The Director, or his duly authorized representative, may conduct such other tests as he may deem necessary to evaluate air pollution emissions other than those noted in of 45CSR§2-4.1.

§2-8.2. Monitoring.

a. The owner or operator of a fuel burning unit(s) shall monitor compliance with 45CSR§2-3 as set forth in an approved monitoring plan for each emission unit. Such monitoring plan(s) shall include, but not be limited to, one or more of the following: continuous measurement of emissions, monitoring of emission control equipment, periodic parametric monitoring, or such other monitoring as approved by the Director.

§2-8.3. Recordkeeping and Reporting.

a. The owner or operator of a fuel burning unit(s) shall maintain on-site all records of monitored data established in the monitoring plan pursuant to of 45CSR§2-8.2.a. Such records shall be made available to the Director or his duly authorized representative upon request. Such records shall be retained on-site for a minimum of five years.

b. The owner or operator shall submit a periodic exception report to the Director, in a manner and at a frequency to be established by the Director. Such exception report shall provide details of all excursions outside the range of measured emissions or monitored parameters established in an approved monitoring plan, and shall include, but not be limited to, the time of the excursion, the magnitude of the excursion, the duration of the excursion, the cause of the excursion and the corrective action taken.

c. The owner or operator shall maintain records of the operating schedule and the quantity and quality of fuel consumed in each fuel burning unit. Such records are to be maintained on-site and made available to the Director or his duly authorized representative upon request.

d. Where appropriate the owner or operator of a fuel burning unit(s) may maintain such records in electronic form.

§2-9.2.

At all times, including periods of start-ups, shutdowns and malfunctions, owners and operators shall, to the extent practicable, maintain and operate any fuel burning unit(s) including associated air pollution control equipment in a manner consistent with good air pollution control practice for minimizing emissions. Determination of whether acceptable operating and maintenance procedures are being used will be based on information available to the Director which may include, but is not limited to, monitoring results, visible emission observations, review of operating and maintenance procedures and inspection of the source.

[45CSR13, Permit Number R13-2141, Condition B.1., Emission Point ID (27E)]

- 4.1.19. The permitted facility shall comply with all applicable requirements of 45CSR10, with the exception of any more stringent limitations set forth in 4.1.17. The principle provisions of 45CSR10, applicable to the permitted facility, are:

§10-3.2.

No person shall cause, suffer, allow, or permit the discharge of sulfur dioxide into the open air from all stacks located at one plant, measured in terms of pounds per hour, in excess of the amount determined as follows:

§10-3.2.c.

For Type 'b' and Type 'c' fuel burning units, the product of 1.6 and the total design heat inputs for such units discharging through those stacks in million BTU's per hour, provided however, that no more than 5,500 pounds per hour of sulfur dioxide shall be discharged into the open air from all such stacks.

§10-8.1.a.

At such reasonable times as the Director may designate, the owner or operator of any fuel burning unit(s), manufacturing process source(s) or combustion source(s) may be required to conduct or have conducted tests to determine the compliance of such source(s) with the emission limitations of sections 3, 4, or 5 of 45CSR10. Such tests shall be conducted in accordance with the appropriate test method set forth in 40CFR Part 60, Appendix A, Method 6, Method 15, or equivalent EPA testing method approved by the Director.

§10-8.3.a.

The owner or operator of fuel burning unit(s), manufacturing process source(s) or combustion source(s) subject to sections 3, 4, or 5 of 45CSR10 shall maintain on-site a record of all required monitoring data as established in a monitoring plan pursuant to 45CSR§10-8.2.c. Such records shall be made available to the Director or his duly authorized representative upon request. Such records shall be retained on-site for a minimum of five (5) years.

[45CSR13, Permit Number R13-2141, Condition B.2, Emission Point ID (27E)]

- 4.1.20. Maximum aggregate emissions to the atmosphere from Emission Point ID No. A-001, A-002, A-003, and A-004 shall not exceed the following hourly and annual limits:

Pollutant	Emissions (lb/hr)	Emissions (tpy)
Nitrogen Oxides	43.4	15.0
Carbon Monoxide	9.4	0.9
PM-10	3.1	0.3
Hydrocarbons	0.5	0.6

[45CSR13, Permit Number R13-2414, Condition 4.1.1., Emission Point ID (A-001, A-002, A-003, A-004)]

- 4.1.21. The permittee is limited to four (4) portable diesel auxiliary air compressors (designated as 001 through 004) on site for the purposes of maintaining adequate pressure and delivery volume in the plant air header in the event that the normal electric driven compressors fail, require maintenance, or lose power supply.

[45CSR13, Permit Number R13-2414, Condition 4.1.2., Emission Unit ID (001, 002, 003, 004)]

- 4.1.22. Reserved.

- 4.1.23. Boiler 26 shall operate at a minimum of 25% of its design heat input, utilizing natural gas, immediately prior to and during combustion of process vent gas from the Covestro LLC plant.

[45CSR13, Permit Number R13-2033, Condition 4.1.12., Emission Unit ID (B26)]

4.1.24. The permittee must operate and maintain the boilers, B26 and B27, including associated air pollution control equipment and monitoring equipment, in a manner consistent with safety and good air pollution control practices for minimizing emissions. Determination of whether such operation and maintenance procedures are being used will be based on information available to the Administrator that may include, but is not limited to, monitoring results, review of operation and maintenance procedures, review of operation and maintenance records, and inspection of the source.

[45CSR34, 40CFR§63.7500(a)(3)]

4.1.25. The permittee shall conduct a tune-up of the boilers, B26 and B27, every 5 years in accordance with the provision of 40CFR63, Subpart DDDDD. Each 5-year tune-up specified in §63.7540(a)(12) must be conducted no more than 61 months after the previous tune-up. The Permittee may delay the burner inspection specified in Condition 4.1.25.1 until the next scheduled or unscheduled unit shutdown, but the Permittee must inspect each burner at least once every 72 months. If an oxygen trim system is utilized on a unit without emission standards to reduce the tune-up frequency to once every 5 years, set the oxygen level no lower than the oxygen concentration measured during the most recent tune-up. If the boiler is not operating on the required date for a tune-up, the tune-up must be conducted within 30 calendar days of startup. The tune-up shall include the following:

4.1.25.1. As applicable, inspect the burner, and clean or replace any components of the burner as necessary (the burner inspection may be performed at any time prior to the tune-up or delay the burner inspection until the next scheduled unit shutdown). At units where entry into a piece of process equipment or into a storage vessel is required to complete the tune-up inspections, inspections are required only during planned entries into the storage vessel or process equipment;

4.1.25.2. Inspect the flame pattern, as applicable, and adjust the burner as necessary to optimize the flame pattern. The adjustment should be consistent with the manufacturer's specifications, if available;

4.1.25.3. Inspect the system controlling the air-to-fuel ratio, as applicable, and ensure that it is correctly calibrated and functioning properly (the inspection may be delayed until the next scheduled unit shutdown);

4.1.25.4. Optimize total emissions of CO. This optimization should be consistent with the manufacturer's specifications, if available, and with any NOx requirement to which the unit is subject;

4.1.25.5. Measure the concentrations in the effluent stream of CO in parts per million, by volume, and oxygen in volume percent, before and after the adjustments are made (measurements may be either on a dry or wet basis, as long as it is the same basis before and after the adjustments are made). Measurements may be taken using a portable CO analyzer.

4.1.25.6. Maintain on-site and submit, if requested by the Director, a tune-up report containing the information in paragraphs 4.1.25.6.1. through 4.1.25.6.3.

4.1.25.6.1. The concentrations of CO in the effluent stream in parts per million by volume, and oxygen in volume percent, measured at high fire of typical operating load, before and after the tune-up of the boiler;

4.1.25.6.2. A description of any corrective actions taken as a part of the tune-up; and

- 4.1.25.6.3. The type and amount of fuel used over the 12 months prior to the tune-up, but only if the unit was physically and legally capable of using more than one type of fuel during that period. Units sharing a fuel meter may estimate the fuel used by each unit.

[45CSR34, 40CFR§63.7500(a)(1) and Table 3, 40CFR§63.7500(e), 40CFR§63.7515(d), 40CFR§63.7540(a), (a)(10)(i) through (vi), (12), and (13)]

4.2. Monitoring Requirements

- 4.2.1. For Boilers B26, and B27 the permittee shall maintain and operate a NOx continuous emission monitoring system during ozone season. In accordance with 45CSR40 NOx emissions during Ozone Season shall be monitored in accordance with 40CFR75, Subpart H.
[45CSR40, Emission Point ID (26E, 27E)]
- 4.2.2. Boilers B26 and B27 are subject to 40CFR60, Subpart Db. The permittee shall comply with all applicable provisions contained in 40CFR60, specifically Subpart Db. As provided by 40CFR§60.48b(2) installation of a nitrogen oxides continuous emission monitoring system (CEMS), which meets the requirements of 40CFR75, Subpart H, also meets the requirements of Subpart Db, except that the permittee shall also meet the requirements of §60.49b. (Data reported to meet the requirements of §60.49b shall not include data substituted using the missing data procedures in subpart D of part 75 of chapter 40, nor shall the data have been bias adjusted according to the procedures of part 75.) All reports, requests, or notifications under Subpart Db shall be submitted as provided by Condition 3.5.3 of this permit.
[45CSR13, Permit Number R13-2141, Condition B.6., 40CFR§60.48(b)(2), 45CSR16, Emission Point ID (26E, 27E)]
- 4.2.3. In order to determine compliance with the annual combustion limit of section 4.1.5 of this permit, the permittee shall maintain monthly records of the amount of natural gas combusted by Boiler 26. Additionally, in order to determine compliance with the hourly combustion limit of section 4.1.5 of this permit, the permittee shall maintain monthly records of the hours of operation of Boiler 26. Compliance with the hourly limit shall be determined by dividing the amount of natural gas consumed during the month by the monthly hours of operation.
[45CSR13, Permit Number R13-2033, Condition 4.2.4., Emission Point ID (26E)]
- 4.2.4. In order to determine compliance with annual combustion limit of section 4.1.6 of this permit, the permittee shall maintain monthly records of the amount of natural gas condensate combusted by Boiler 26. Additionally, in order to determine compliance with the hourly combustion limit of section 4.1.6 of this permit, the permittee shall maintain monthly records of the hours of operation of Boiler 26. Compliance with the hourly limit shall be determined by dividing the amount of natural gas condensate consumed during the month by the monthly hours of operation.
[45CSR13, Permit Number R13-2033, Condition 4.2.5., Emission Point ID (26E)]
- 4.2.5. In order to determine compliance with annual combustion limit of section 4.1.3 of this permit, the permittee shall maintain monthly records of the amount of process vent gas from Covestro LLC combusted by Boiler 26.
[45CSR13, Permit Number R13-2033, Condition 4.2.6., Emission Point ID (26E)]
- 4.2.6. Reserved.

- 4.2.7. The permittee shall comply with all applicable monitoring and recordkeeping requirements of 40CFR60 Subpart Db including but not limited to the following:

4.2.7.1 The permittee shall install, calibrate, maintain, and operate CEMS for measuring NO_x and O₂(or CO₂) emissions discharged to the atmosphere, and shall record the output of the system. As provided by 40 CFR§60.48b(b)(2), installation of a CEMS meeting the requirements of 40CFR75, Subpart H, meets the requirements of Subpart Db, except as otherwise provided by 40CFR§60.48b.

[40CFR§60.48b(b), 45CSR16, 45CSR13, Permit Number R13-2033, Condition 4.2.8., Emission Point ID (26E)]

- 4.2.8. The permittee shall comply with all applicable monitoring and recordkeeping requirements of 40CFR63 Subpart PPP.

[45CSR13, Permit Number R13-2033, Condition 4.2.9., Emission Point ID (26E)]

- 4.2.9. Reserved.

- 4.2.10. The permittee shall conduct visible emission (VE) checks and/or opacity monitoring and recordkeeping for the emission points corresponding to Boilers B26 and B27.

The visible emission check shall determine the presence or absence of visible emissions. At a minimum, the observer must be trained and knowledgeable regarding the effects of background contrast, ambient lighting, observer position relative to lighting, wind, and the presence of uncombined water (condensing water vapor) on the visibility of emissions. This training may be obtained from written materials found in References 1 and 2 from 40CFR Part 60, Appendix A, Method 22 or from the lecture portion of the 40CFR Part 60, Appendix A, Method 9 certification course.

For Boiler B26 visible emission checks shall be conducted at least once per calendar month when natural gas condensate is burned. Additionally, visible emission checks shall be conducted on Boilers B26 and B27 at least once annually when process vent gas streams (Covestro LLC's Propylene Oxide Regeneration System) are controlled by the boilers. When Covestro LLC propylene oxide vent gas is burned, the permittee shall conduct the VE check during the de-activation step of the process which represents the condition of highest propylene oxide loading. The permittee shall document the specific process vent gas stream(s) venting to the boiler during the check(s). These checks shall be performed for a sufficient time interval, but no less than one (1) minute, to determine if any visible emissions are present. Visible emission checks shall be performed during periods of operation as specified above and appropriate weather conditions.

If visible emissions are present for three (3) consecutive monthly checks, or any one of the annual checks the permittee shall conduct an opacity reading at that source(s) using the procedures and requirements of Method 9 as soon as practicable, but within seventy-two (72) hours of the final visual emission check. Method 9 checks shall be performed on the source for at least six (6) minutes. A Method 9 observation at a source(s) restarts the count of the number of consecutive readings with the presence of visible emissions.

[45CSR§30-5.1.c., 45CSR13, Permit Number R13-2033, Condition 4.2.11., Emission Point ID (26E, 27E)]

- 4.2.11. The permittee shall monitor the hours of operation for each auxiliary compressor (001-004).

[45CSR13, Permit Number R13-2414, Condition 4.2.1., Emission Unit ID (001, 002, 003, 004)]

- 4.2.12. At the end of each month, the permittee shall perform calculations using the monthly hours of operations, the horsepower rating of any compressors used that month and appropriate emission factors (either AP-42 or factors developed by the engine manufacturer) to show compliance with section 4.1.20 of this permit. Additionally, the permittee may (at the permittee's discretion) use fuel usage based emission factors (either AP-42 or factors developed by the engine manufacturer) if fuel usage was monitored and recorded for that entire month. Once the monthly emissions are calculated, a rolling twelve-month total of emissions shall be calculated.

[45CSR13, Permit Number R13-2414, Condition 4.2.2., Emission Unit ID (001, 002, 003, 004)]

- 4.2.13. In order to determine compliance with the propylene oxide emission limits in section 4.1.1 of this permit, the permittee shall monitor and record actual propylene oxide loading (on at least an hourly basis) to the boiler during combustion of process vent gas from the Covestro LLC facility. The permittee shall use this data to calculate actual hourly and annual propylene oxide emissions. When calculating emissions, a 98% control efficiency may be used provided all applicable conditions of 40CFR63 Subpart PPP have been met. Compliance with the annual limit of 4.1.1 shall be based on a rolling 12-month total.
[45CSR13, Permit Number R13-2033, Condition 4.2.12., Emission Point ID (26E)]

4.3. Testing Requirements

- 4.3.1. In order to determine compliance with the hexane emission limits in section 4.1.1 of this permit, within 180 days of commencement of process vent gas and/or liquid natural gas condensate combustion in Boiler 26 (whichever comes first) the permittee shall complete the following performance testing:
- 4.3.1.1 The permittee shall perform or have performed EPA approved stack tests to determine emissions of hexane from Boiler 26. Said testing shall be performed while the boiler is combusting natural gas condensate as close to practical a feed rate of approximately 100 gallons per hour.
[45CSR§13-5.10.]
[45CSR13, Permit Number R13-2033, Condition 4.3.1., Emission Point ID (26E)]
- 4.3.2. The permittee shall comply with all applicable testing requirements of 40CFR63 Subpart PPP.
[45CSR13, Permit Number R13-2033, Condition 4.3.2., Emission Point ID (26E)]
- 4.3.3. Reserved.
- 4.3.4. The permittee shall comply with all applicable testing requirements of 40CFR60 Subpart Db.
[45CSR13, Permit Number R13-2033, Condition 4.3.4., Emission Point ID (26E)]
- 4.3.5. After the testing required by 4.3.1 of this permit is completed, ongoing compliance shall be demonstrated by repeating the testing required by 4.3.1 according to the following schedule:

Test	Test Results	Testing Frequency
Initial	< 50% of limits	Upon Director's Request
Initial	Between 50% and 90% limits	Once/5 years
Initial	≥90% of limits	Once/3 years
Once/3 years	After two successive tests indicate emission rates ≤50% of limits	Upon Director's Request
Once/3 years	After two successive tests indicate emission rates <90% of limits	Once/5 years
Once/3 years	≥90% of limits	Once/3 years
Once/5 years	After two successive tests indicate emission rates <50% of limits	Upon Director's Request

Test	Test Results	Testing Frequency
Once/5 years	After two successive tests indicate emission rates < 90% of limits	Once/5 years
Once/5 years	≥90% of limits	Once/3 years

[45CSR13, Permit Number R13-2033, Condition 4.3.5., Emission Point ID (26E)]

4.3.6. Reserved.

4.4. Recordkeeping Requirements

4.4.1. The permittee shall maintain accurate records of the amount of natural gas consumed in Boiler B27 on a monthly and yearly basis using the sample record keeping format, or equivalent, as supplied within Attachment A of permit number R13-2141C, also included herein as Attachment A

[45CSR13, Permit Number R13-2141, Condition B.5., Emission Unit ID (B27)]

4.4.2. Manufacturer's specification sheets shall be kept on file for the portable diesel auxiliary air compressors (designated as equipment IDs. 001 through 004 of this permit) on site.

[45CSR13, Permit Number R13-2414, Condition 4.4.5., Emission Unit ID (001, 002, 003, 004)]

4.4.3. The permittee shall maintain accurate records of the hours of operation for each portable auxiliary air compressor (designated as equipment ID(s) 001 through 004 of this permit). All applicable records shall be maintained in such a form suitable and readily available for expeditious inspection and review. The files shall be maintained for at least five (5) years following the date of each occurrence, measurement, maintenance, corrective action, report, or record. At a minimum, the most recent two (2) years of data may be maintained off site, but must remain accessible within a reasonable time. Where appropriate, the permittee may maintain records electronically (on a computer, on computer floppy disks, CDs, DVDs, or magnetic tape disks), on microfilm, or on microfiche.

[45CSR13, Permit Number R13-2414, Condition 4.4.4., Emission Unit ID (001, 002, 003, 004)]

4.4.4. The permittee must keep a record of each notification and report submitted, including all documentation supporting any Initial Notification or Notification of Compliance Status or semiannual compliance report submitted, according to the requirements in 40 C.F.R. §63.10(b)(2)(xiv).

[45CSR34, 40 C.F.R. §63.7555(a)(1)]

4.4.5. The permittee must keep records specified in Condition 4.4.4. as follows:

- a. The records must be in a form suitable and readily available for expeditious review, according to 40 C.F.R. §63.10(b)(1).
- b. As specified in 40 C.F.R. §63.10(b)(1), the Permittee must keep each record for 5 years following the date of each occurrence, measurement, maintenance, corrective action, report, or record.
- c. The Permittee must keep each record on site, or they must be accessible from on site (for example, through a computer network), for at least 2 years after the date of each occurrence, measurement, maintenance, corrective action, report, or record, according to 40 C.F.R. §63.10(b)(1). The Permittee can keep the records off site for the remaining 3 years.

[45CSR34, 40 C.F.R. §63.7560]

4.5. Reporting Requirements

- 4.5.1. Reserved.
- 4.5.2. The permittee shall submit semi-annual reports of nitrogen oxide emissions for Boilers B26 and B27 as required by 40CFR60, Subpart Db.
[45CSR13, Permit Number R13-2033, Condition 4.4.3., 40CFR60, Subpart Db., Emission Point ID (26E, 27E)]
- 4.5.3. Any violations of the allowable visible emission requirement for any emission source discovered during testing must be reported in writing to the Director of the Division of Air Quality as soon as practicable, but within ten calendar days, of the occurrence and shall include, at a minimum, the following information: the results of the visible determination of opacity of emissions, the cause or suspected cause of the violation(s), and any corrective measures taken or planned.
[45CSR13, Permit Number R13-2033, Condition 4.4.1., Emission Point ID (26E)]
- 4.5.4. The permittee must submit a 40 C.F.R. 63 Subpart DDDDD compliance report for Boiler 26 and 27 every five years. The first report will cover the reporting period of January 31, 2016 to December 31, 2021. Each subsequent 5-year report will cover the period from January 1 to December 31st. The compliance report shall be submitted by March 15th following the reporting period.
[45CSR34, 40 C.F.R. §§63.7550(a) and (b)]
- 4.5.5. A compliance report must contain the following information;
- (i) Company and Facility name and address.
 - (ii) Process unit information, emissions limitations, and operating parameter limitations.
 - (iii) Date of report and beginning and ending dates of the reporting period.
 - (iv) Include the date of the most recent tune-up for each unit subject to only the requirement to conduct an annual, biennial, or 5-year tune-up according to §63.7540(a)(10), (11), or (12) respectively. Include the date of the most recent burner inspection if it was not done annually, biennially, or on a 5-year period and was delayed until the next scheduled or unscheduled unit shutdown.
 - (v) Statement by a responsible official with that official's name, title, and signature, certifying the truth, accuracy, and completeness of the content of the report.

Compliance reports required by Condition 4.5.4. shall be submitted electronically to the EPA via the CEDRI. The permittee must use the appropriate electronic report in CEDRI for this subpart. Instead of using the electronic report in CEDRI for this subpart, the permittee may submit an alternate electronic file consistent with the XML schema listed on the CEDRI Web site (<http://www.epa.gov/ttn/chief/cedri/index.html>), once the XML schema is available. If the reporting form specific to this subpart is not available in CEDRI at the time that a report is due, submit the report to the Director.

[45CSR34, 40 C.F.R. §§63.7550(c)(5)(i) through (iii), (xiv), (xvii) and (h)(3)]

4.6. Compliance Plan

- 4.6.1. N/A

5.0 Source-Specific Requirements [Specialty Surfactants (Triton™), Unit ID(s) (listed under Specialty Surfactants within Section 1.0)]

5.1. Limitations and Standards

5.1.1. Emissions to the atmosphere from the Specialty Surfactants Plant shall be limited to the hourly and annual emission limits established in Table 5.1.1.

Table 5.1.1. Emission Limits for Specialty Surfactants Process

Emission Point ID No.	Pollutant	Emission Limits	
		pph	tpy
E-1081-3, E-1081-2, E-1084-1, E-1084-2, E-1085-1, E-1085-2, E-1086-1, E-1086-3, E-1086-4, E-1088-1	SO ₂	—	0.25
	VOC	88.0	9.88
	Ethylene Oxide	0.65	0.0445
	Propylene Oxide	10.8	0.62
	Formaldehyde	0.17	0.0200
	Ethylene Dichloride THAP ¹	0.088 45.0	0.009 2.27
T-8313, T-8314, T-8320, T-8321, T-8322, T-8323, T-8324, T-8331, T-8332, T-8333, T-8334, T-8341, T-8343, T-8344, T-8345, T-8346, T-8350, T-8351, T-8352, T-8354, T-8355, T-8356, T-8360, T-8361, T-8362, T-8363, T-8364, T-8365, T-8366, T-8371, T-8372, T-8373, T-8375, T-8376, T-8380, T-8381, T-8383, T-8390, T-8391, T-8392, T-8393, T-8420, T-8433, T-8435, T-8517, T-8520, T-8706, T-8750, T-8817, T-8835, L-1001, L-1002, L-1003, L-1004, L-1005	PM ₁₀	0.2	0.02
	VOC	69.0	2.45
	Ethylene Oxide	0.09	0.02
	Formaldehyde	0.16	0.02
	Propylene Oxide	12.8	0.1209
	THAP ¹	26.0	0.17
E-1086-7	Ethylene Glycol	0.01	0.001
T-8330	No Regulated Air Pollutant	NA	NA
T-8738	No Regulated Air Pollutant	NA	NA

¹THAP includes: ethylene oxide, propylene oxide, formaldehyde, ethylene dichloride, acetaldehyde, benzyl chloride, cresylic acid, 1,4-dioxane, ethylene glycol, glycol ethers, methanol, toluene, and other HAPs that could be present as trace constituents in raw materials.

[45CSR13, Permit Number R13-1517, Condition 4.1.1., Emission Point ID (Above in Table 5.1.1)]

5.1.2. All emissions from the operation of the 8500 Reactor, with the exception of emissions from the production of Product CF-10, Product DF-12, or Product DF-18, shall be directed first through the Caustic Scrubber (C-8110) and then through the Water Scrubber (C-8130). Emissions from the production of Product CF-10, Product DF-12, and Product DF-18, may be directed from the 8500 Reactor directly to the Water Scrubber (C-8130).

[45CSR13, Permit Number R13-1517, Condition 4.1.2., Emission Unit ID (8500 Reactor)]

5.1.3. The permittee shall ensure complete reaction by redundant measurement and interlock of starter charge, Ethylene Oxide and Propylene Oxide feed, temperature, and pressure. The process interlock shall prevent venting until the preset criteria for complete reaction are met. These criteria must include positive isolation of Ethylene Oxide and Propylene Oxide feed.

[45CSR13, Permit Number R13-1517, Condition 4.1.3., Emission Unit ID (8400)]

- 5.1.4. *Operation and Maintenance of Air Pollution Control Equipment.* The permittee shall, to the extent practicable, install, maintain, and operate all pollution control equipment listed in Section 1.0 and associated monitoring equipment in a manner consistent with safety and good air pollution control practices for minimizing emissions, or comply with any more stringent limits set forth in this permit or as set forth by any State rule, Federal regulation, or alternative control plan approved by the Secretary.

[45CSR§13-5.10., 45CSR13, Permit Number R13-1517, Condition 4.1.4., Equipment ID(s) (C-8110, C-8130)]

- 5.1.5. Emissions from the equipment identified in 5.1.1 above shall be routed to and controlled by those control devices identified in Section 1.0 under Specialty Surfactants prior to venting emissions to the atmosphere, excepting only periods of emergency repairs of control equipment and unanticipated control equipment failure for reasons beyond the reasonable control of the permittee, or as otherwise allowed by this permit or applicable regulation.

In the event that both the Caustic Scrubber (C-8110) and the Water Scrubber (C-8130) are off-line (e.g. due to plant turnaround), storage tank emissions that normally vent to the scrubber system are authorized to be discharged directly to the air. During such outages, there shall be no materials transferred into tanks that normally vent to the scrubber system.

Due to unavoidable malfunction of equipment or other conditions resulting in emissions exceeding the levels established in this permit, the Director may grant the permittee a variance to operate the related production equipment for periods not to exceed ten (10) days upon specific application to the Director. Such application shall be made within twenty-four (24) hours of the malfunction. In cases of major equipment failure, additional time periods may be granted by the Director provided a corrective program has been submitted by the permittee and approved by the Director. During such times, the permittee shall take all reasonable and practicable steps to minimize emissions.

[45CSR13, Permit Number R13-1517, Condition 4.1.5., Equipment ID(s) (C-8110, C-8130)]

- 5.1.6. The permittee shall implement a Leak Detection and Repair Program (“LDAR”) compliant with the HON equipment leak requirements in 40CFR63, Subpart H for all equipment covered by 40CFR63, Subpart PPP (as well as equipment in TAP service). For the remainder of the Specialty Surfactants Plant, the permittee shall implement a LDAR Program compliant with 45CSR§21-37, excluding the fugitive emission components associated with the equipment listed below that have been determined as insignificant fugitive emission sources provided that the total organic liquid vapor pressure is maintained at or below 0.01 mm Hg at 20°C.

Tanks 8323, 8324, 8332, 8333, 8343, 8344, 8353, 8354, 8363, 8364, 8373, 8381, 8382, 8383, and 8706.

For equipment components in the Specialty Surfactants Plant that are in light liquid service less than 300 hours per year, the permittee shall implement a LDAR Program compliant with the heavy liquid provisions of 45CSR§21-37. Periodic reports required by the LDAR program may be submitted as part of the semi-annual periodic reports required by Section 5.5.3.

[45CSR13, Permit Number R13-1517, Condition 4.1.6., 40CFR§63.1434, CO-R21-98-22, Equipment (VOC/HAP/TAP service)]

- 5.1.7. The permittee shall comply with all applicable standards and requirements of 40CFR Part 63 Subpart PPP – “National Emission Standards for Hazardous Air Pollutants for Polyether Polyols Production”. The subpart includes requirements to limit HAP emissions from polyether polyols manufacturing units – which includes purification systems, reactors and their associated product separator and recovery devices, other associated unit operations, storage vessels, surge control vessels, bottoms receivers, product transfer racks, connected ducts and piping, combustion, recovery, or recapture devices or systems, and equipment leaks. This subpart also includes specific notification, testing, monitoring, recordkeeping, and reporting requirements. The pertinent sections of 40CFR§63.1420 applicable to this facility include, but are not limited to, the following:

[40CFR§63.1420, 45CSR34]

- 5.1.7.1 The permittee shall reduce the total epoxide emissions from the applicable 40CFR63 Subpart PPP process vents of the Specialty Surfactants Plant by an aggregated 98 percent.
[40CFR§63.1425(b)(2)(ii), 45CSR34, 45CSR13, Permit Number R13-1517, Condition 4.1.7., Equipment ID (8400)]
- 5.1.8. The permittee shall comply with all applicable requirements of 45CSR7 “To Prevent and Control Particulate Matter Air Pollution from Manufacturing Processes and Associated Operations”, with the exception of any more stringent limitations set forth in this permit.
- 5.1.8.1. The permittee shall not cause, suffer, allow or permit emission of smoke and/or particulate matter into the open air from any process source operation which is greater than twenty (20) percent opacity, except as noted in Sections 5.1.8.2 and 5.1.8.3.
[45CSR§7-3.1.] {T-8706}
- 5.1.8.2. The provisions of Section 5.1.8.1 shall not apply to smoke and/or particulate matter emitted from any process source operation which is less than forty (40) percent opacity for any period or periods aggregating no more than five (5) minutes in any sixty (60) minute period.
[45CSR§7-3.2.] {T-8706}
- 5.1.8.3. The permittee shall not cause, suffer, allow or permit visible emissions from any storage structure(s) associated with any manufacturing process(es) that pursuant to Section 5.1.8.4 is required to have a full enclosure and be equipped with a particulate matter control device.
[45CSR§7-3.7.]
- 5.1.8.4. The permittee shall not cause, suffer, allow or permit any manufacturing process or storage structure generating fugitive particulate matter to operate that is not equipped with a system, which may include, but not be limited to, process equipment design, control equipment design or operation and maintenance procedures, to minimize the emissions of fugitive particulate matter. To minimize means such system shall be installed, maintained and operated to ensure the lowest fugitive particulate matter emissions reasonably achievable.
**[45CSR§7-5.1]
[45CSR13, Permit Number R13-1517, Condition 4.1.8]**
- 5.1.9. The permittee shall comply with all applicable requirements of 45CSR21 “Regulation to Prevent and Control Air Pollution from the Emission of Volatile Organic Compounds”, with the exception of any more stringent limitations set forth in this permit. Specific emission limits under 45CSR21, which pertain to the Specialty Surfactants Area can be found in Section 9.0 of this Title V Permit.
[45CSR13, Permit Number R13-1517, Condition 4.1.9., Emission Point ID (E-1081-3, T-8352, T-8362, and L-1004)]

5.1.10. The permittee shall comply with all applicable requirements of 45CSR27 “To Prevent and Control the Emissions of Toxic Air Pollutants”, with the exception of any more stringent limitations set forth in this permit. Specific emission limits under 45CSR27, which pertain to the Specialty Surfactants Area can be found in Section 8.0 of this Title V Permit.

[45CSR13, Permit Number R13-1517, Condition 4.1.10., Emission Unit ID (8400)]

5.1.11. The heat exchanger systems used in the Specialty Surfactants Plant to cool process equipment or materials that are covered by 40CFR63, Subpart PPP shall operate with a cooling pressure fluid at least 5 psig greater than the maximum pressure on the process fluid side or are operated as once through cooling water subject to an NPDES permit that meets the requirements of 40CFR§63.104(a)(3) and therefore meet the exemption from the heat exchanger monitoring requirements of 40CFR§63.104(a).

[40CFR§63.104(a), 45CSR34]

5.1.12. **MON MACT.** The permittee shall comply with the following provisions for wastewater as specified by 40 C.F.R. §63.2485(i).

Process wastewater stream ID TR020/GR-7M Decant is classified as Group 1 wastewater. As provided by the NOCS, TR020/GR-7M Decant must be managed as hazardous waste and shipped to an off-site facility authorized to manage hazardous waste.

The permittee shall develop and maintain a maintenance wastewater plan that is implemented per §63.2485(a) and §63.105, except as specified in §63.2485.

[40 C.F.R. §63.2485, 45CSR34; Wastewater Stream ID (TR020/GR-7M Decant)]

5.1.13. **MON MACT.** The permittee shall comply with the following general requirements for emission limits, work practice standards and compliance requirements as specified by §63.2450.

- The Solvent Recovery Column (Eq. Id. 8101), Group 2 Continuous Process Vent, must be operated with a total resource effectiveness (TRE) index greater than 5.0.
- Rail car and tank truck loading racks used to load organic liquids containing hazardous air pollutants shall be operated as Group 2 transfer operations as defined by the MON Rule. (Rack IDs: L-1001, L-1003, L-1004 and L-1005).
- The following storage vessels shall be operated as Group 2 as defined by the MON Rule.
 (Storage Vessel IDs: T8310, T8320, T8321, T8324, T8345, T8346, T8351, T8355, T8356, T8360, T8361, T8362, T8364, T8365, T8366, T8373, T8375, T8376, T8382, and T8817.

[45CSR34, 40 C.F.R. §63.2450]

5.1.14. **MON MACT.** The permittee shall comply with the applicable equipment leak standards of the MON MACT as specified by 40 C.F.R. §63.2480(b), Subpart H of 40 C.F.R. 63, except as specified in 40 C.F.R. §63.2480(e) and (f). As a result, the permittee has defined the following schedule within their NOC report.

Phase	Planned Schedule for Implementation On or Before
Phase I – Beginning on the compliance date	May 10, 2008
Phase II – Beginning no later than 1 year after the compliance date	May 10, 2009
Phase III – Beginning no later than 2 ½ years after the compliance data	November 8, 2010

[45CSR34, 40 C.F.R. §63.2480]

5.1.15. **MON MACT.** The permittee shall comply with the applicable general provisions of 40 C.F.R.63 Subpart A as specified by 40 C.F.R. §63.2540 and Table 12 of Subpart FFFF.

[45CSR34, 40 C.F.R. §63.2540; 40 C.F.R. 63 Table 12 to Subpart FFFF]

5.1.16. **Requirements for pressure relief devices covered by 40CFR63 Subpart PPP.** The permittee must comply with the operating and pressure release requirements specified in paragraphs (a) and (b) of this condition for pressure relief devices in organic HAP gas or vapor service. The permittee must also comply with the pressure release management requirements specified in paragraph (c) of this condition for all pressure relief devices in organic HAP service.

- a. Operating requirements. Except during a pressure release event, operate each pressure relief device in organic HAP gas or vapor service with an instrument reading of less than 500 ppm above background as detected by Method 21 of 40CFR part 60, appendix A.
- b. Pressure release requirements. For pressure relief devices in organic HAP gas or vapor service, comply with the following requirements, as applicable.
 1. If the pressure relief device does not consist of or include a rupture disk, conduct instrument monitoring, as detected by Method 21 of 40CFR part 60, appendix A, no later than 5 calendar days after the pressure release to verify that the pressure relief device is operating with an instrument reading of less than 500 ppm above background, except as provided in 40CFR§63.171.
 2. If the pressure relief device consists of or includes a rupture disk, install a replacement disk as soon as practicable after a pressure release, but no later than 5 calendar days after the pressure release, except as provided in 40CFR§63.171.

Pressure release management. Pressure releases to the atmosphere from pressure relief devices in organic HAP service are prohibited.

- c. Effective March 27, 2017, the permittee must comply with the following requirements for all pressure relief devices in organic HAP service:
 1. For each pressure relief device in organic HAP service, the owner or operator must equip each pressure relief device with a device(s) or use a monitoring system that is capable of:
 - i. Identifying the pressure release;
 - ii. Recording the time and duration of each pressure release; and
 - iii. Notifying operators immediately that a pressure release is occurring. The device or monitoring system may be either specific to the pressure relief device itself or may be associated with the process system or piping, sufficient to indicate a pressure release to the atmosphere. Examples of these types of devices and systems include, but are not limited to, a rupture disk indicator, magnetic sensor, motion detector on the pressure relief valve stem, flow monitor, or pressure monitor.

2. If any pressure relief device in organic HAP service releases to atmosphere as a result of a pressure release event, the owner or operator must calculate the quantity of organic HAP released during each pressure release event and report this quantity as required in §63.1439(e)(6)(ix). Calculations may be based on data from the pressure relief device monitoring alone or in combination with process parameter monitoring data and process knowledge.

[45CSR34 and 40CFR§§63.1434(c)(1), (2), and (3)]

5.2. Monitoring Requirements

- 5.2.1. The permittee shall install, calibrate, and maintain in good working condition the following equipment and record and maintain data from these devices:

a. Caustic Scrubber (C-8110) – Ethylene Oxide and Propylene Oxide Venting

- i. Continuous monitoring and recording instrumentation with automatic alarm to ensure that scrubber liquid level is sufficient and add solution to maintain at least 100 gallons in the base section with the circulation pump on.
- ii. Scrubber circulation flow monitor, alarm, and interlock to prevent venting at less than 6 gpm (3,000 pph) of water flow.
- iii. Scrubber liquid temperature monitor, alarm, and interlock to prevent venting at less than 75°C, (167°F) base liquid temperature.
- iv. 8400 Reactor pressure monitor to automatically control vapor flow to the packed bed scrubber at 120 scfm or less.
- v. Scrubber differential pressure monitor, alarm, and interlock to override reactor pressure control to maintain scrubber differential pressure at 25 inches of water or lower.
- vi. The permittee shall sample, titrate, and record scrubber caustic concentration once per shift during operation and add NaOH as required to maintain at least 2% NaOH concentration.
- vii. The permittee shall blow down half of the scrubber liquid and replace with fresh solution at least weekly. This activity must be performed during periods when the 8400 Reactor is not venting.

b. Water Scrubber (C-8130)

- i. Continuous monitoring and recording instrumentation with automatic alarm to ensure that scrubber liquid level is sufficient and add solution to maintain at least 100 gallons in the base section with the circulation pump on.
- ii. Scrubber make-up water flow monitor, alarm, and interlock to prevent venting at less than 6 gpm (3,000 pph) make-up flow.
- iii. Scrubber liquid temperature monitor, alarm, and interlock to prevent venting at greater than 35°C (95°F) base liquid temperature.
- iv. Scrubber differential pressure monitor, alarm, and interlock to override reactor pressure control to maintain scrubber differential pressure at 25 inches of water or lower.

[45CSR13, Permit Number R13-1517, Condition 4.2.1., Equipment ID (C-8110, C-8130)]

- 5.2.2. The permittee shall monitor time from the end of the epoxide feed to the end of the Extended Cook-Out (“ECO”);

[40CFR§63.1427(i), 45CSR34, 45CSR13, Permit Number R13-1517, Condition 4.2.2., Equipment ID 8400]

- 5.2.3. For the purpose of determining compliance with the opacity limits of 45CSR7, the permittee shall conduct visible emission checks and/or opacity monitoring and recordkeeping for all emission sources subject to an opacity limit.

The visible emission check shall determine the presence or absence of visible emissions. At a minimum, the observer must be trained and knowledgeable regarding the effects of background contrast, ambient lighting, observer position relative to lighting, wind, and the presence of uncombined water (condensing water vapor) on the visibility of emissions. This training may be obtained from written materials found in the References 1 and 2 from 40CFR Part 60, Appendix A, Method 22 or from the lecture portion of the 40CFR Part 60, Appendix A, Method 9 certification course.

Visible emission checks shall be conducted each time that solid material is unloaded to Vessel 8701. These checks shall be performed at each source (stack, transfer point, fugitive emission source, etc.) for a sufficient time interval, but no less than one (1) minute, to determine if any visible emissions are present. Visible emission checks shall be performed during periods of facility operation and appropriate weather conditions.

If visible emissions are present, the permittee shall conduct an opacity reading at that source(s) using the procedures and requirements of 45CSR§7A as soon as practicable, but within seventy-two (72) hours of the visual emission check unless corrective action is taken to eliminate the visible emissions.

[45CSR13, Permit Number R13-1517, Condition 4.2.3., 45CSR§30-5.1.c.1.B., Emission Point ID (T-8706)]

5.3. Testing Requirements

- 5.3.1. At the request of the Secretary a performance test shall be conducted to confirm compliance with emission limitations set forth in Section 5.1.1., and to confirm correlation between on-line computer simulation determinations and actual measurements during subject performance tests. Results of such performance tests shall be submitted to the Director of the Division of Air Quality within ninety (90) days following the completion of the aforementioned tests. Tests shall be conducted under those production conditions in which peak emission rates will occur. Thirty (30) days prior to conducting such performance tests, a test protocol shall be submitted to the Director for his approval. The Director must be notified at least fifteen (15) days in advance of the actual dates and times during which the tests will be conducted.

[45CSR§13-6.1; 45CSR13, Permit Number R13-1517, Condition 4.3.1]

- 5.3.2. *Stack testing.* At such reasonable times as the Secretary may designate, the permittee may be required to conduct or have conducted stack tests to determine the particulate matter loading in exhaust gases when the Secretary has reason to believe that an emission limitation is being violated. For cause, the Secretary may request the permittee to install such stack gas monitoring devices as the Secretary deems necessary to determine continuing compliance. The data from such devices shall be readily available for review on-site or at such other reasonable location that the Secretary may specify. At the request of the Secretary, such data shall be made available for inspection or copying and the Secretary may require periodic submission of excess emission reports.

[45CSR13, Permit Number R13-1517, Condition 4.3.2., Emission Point ID (T-8706)]

- 5.3.3. *Compliance testing.* Any such test to determine compliance with particulate matter limitations set forth in Section 5.1.1 shall be conducted in accordance with Method 5 of 40CFR60 Appendix A or Method 201 or 201A of 40CFR§51. All such compliance tests must consist of not less than three (3) test runs; any test run duration shall not be less than sixty (60) minutes and no less than thirty (30) standard cubic feet of exhaust gas must be sampled during each test run. Such tests shall be conducted under such reasonable operating conditions as the Secretary may specify. The Secretary, or a duly authorized representative, may option to witness or conduct such stack tests.

Should the Secretary exercise this option to conduct such tests, the registrant shall provide all necessary sampling connections and sampling ports located in a manner as the Secretary may require, power for test equipment and required safety equipment in place such as scaffolding, railings and ladders in order to comply with generally accepted good safety practices.

{T-8706}

[45CSR13, Permit Number R13-1517, Condition 4.3.3.]

- 5.3.4. Any stack serving any process source operation or air pollution control device on any process source operation shall contain flow straightening devices or a vertical run of sufficient length to establish flow patterns consistent with acceptable stack sampling procedures.

[45CSR§7-4.12.] {T-8706}

[45CSR13, Permit Number R13-1517, Condition 4.3.4]

- 5.3.5. *Opacity testing.* Any test to determine compliance with the visible emission (opacity) limitations set forth in Sections 5.1.8, except as provided by Condition 5.2.3., shall be conducted by a qualified visible emission observer in accordance with 45CSR7A – “Compliance Test Procedures for 45CSR7 – *To Prevent and Control Particulate Air Pollution from Manufacturing Process Operations*” and Method 22 of 40CFR60 Appendix A. Nothing in this section, however, shall preclude any permittee or the Secretary from using opacity data from a properly installed, calibrated, maintained and operated continuous opacity monitor as evidence to demonstrate compliance or a violation of visible emission requirements. If continuous opacity monitor data results are submitted when determining compliance with visible emission limitations for a period of time during which 45CSR7A or Method 22 data indicates noncompliance, the 45CSR7A or Method 22 data shall be used to determine compliance with the visible emission limitations.

{T-8706}

[45CSR13, Permit Number R13-1517, Condition 4.3.5]

- 5.3.6. *Notification of compliance testing.* For any stack emission compliance test to be conducted by the permittee as set forth in Section 5.3, a test protocol shall be submitted to the Secretary at least thirty (30) calendar days prior to the scheduled date of the test. Such compliance test protocol shall be subject to approval by the Secretary. The permittee shall notify the Secretary at least fifteen (15) days in advance of actual test dates and times during which the test (or tests) will be conducted.

[45CSR13, Permit Number R13-1517, Condition 4.3.6]

- 5.3.7. *Alternative test methods.* The Director, or his duly authorized representative, may conduct such other tests as he or she may deem necessary to evaluate air pollution emissions.

[45CSR§7-8.2., 45CSR13, Permit Number R13-1517, Condition 4.3.7]

5.4. Recordkeeping Requirements

- 5.4.1. *Record of Maintenance of Air Pollution Control Equipment.* For all pollution control equipment listed in Section 1.0 of permit Number R13-1517 and any amendments thereto, the permittee shall maintain accurate records of all required pollution control equipment inspection and/or preventative maintenance procedures. This provision applies to Caustic Scrubber C-8110, and Water Scrubber C-8130.

[45CSR13, Permit Number R13-1517, Condition 4.4.2., Equipment ID(s) (C-8110, C-8130)]

- 5.4.2. *Record of Malfunctions of Air Pollution Control Equipment.* For all air pollution control equipment listed in Section 1.0 of permit Number R13-1517 and any amendments thereto, the permittee shall maintain records of the occurrence and duration of any malfunction or operational shutdown of the air pollution control equipment during which excess emissions occur. This provision applies to Caustic Scrubber C-8110, and Water Scrubber C-8130. For each such case, the following information shall be recorded:

- a. The equipment involved.
- b. Steps taken to minimize emissions during the event.
- c. The duration of the event.
- d. The estimated increase in emissions during the event.

For each such case associated with an equipment malfunction, the additional information shall also be recorded:

- e. The cause of the malfunction.
- f. Steps taken to correct the malfunction.
- g. Any changes or modifications to equipment or procedures that would help prevent future recurrences of the malfunction.

[45CSR13, Permit Number R13-1517, Condition 4.4.3 Equipment ID(s) (C-8110, C-8130)]

- 5.4.3. Compliance with Sections 5.4.1 and 5.4.2 may be shown by keeping similar records required by the requirements of the Startup, Shutdown, and Malfunction Plan as contained in 40CFR63 Subpart A and as may be amended by specific MACT subpart requirements.

[45CSR13, Permit Number R13-1517, Condition 4.4.4., Equipment ID(s) (C-8110, C-8130, E-1085)]

- 5.4.4. To ensure proper operation of Reactor 8400 the permittee shall verify and record that the correct amount of active catalyst has been charged for each batch, except for those reactions which are self-initiating.

[45CSR13, Permit Number R13-1517, Condition 4.4.5., Equipment ID (8400 Reactor)]

- 5.4.5. Unless otherwise specified in this permit, the permittee shall keep copies of all applicable records and reports required by section 5 of this permit and by 40CFR63 Subpart PPP for at least five (5) years. All applicable records shall be maintained in such a manner that they can be readily accessed. The most recent six months of records shall be retained on site or shall be accessible from a central location by computer or other means that provide access within a reasonable time. Access to the most recent six months of records required by 40CFR63 Subpart PPP must be provided within two hours after a request. The remaining four and one-half years of records may be retained offsite. If the permittee submits copies of reports to the WV DAQ and US EPA Regional Office, the permittee is not required to maintain copies of reports. Records may be maintained in hard copy or computer-readable form including, but not limited to, on microfilm, computer, floppy disk, magnetic tape, or microfiche.

[45CSR13, Permit Number R13-1517, Condition 4.4.6]

- 5.4.6. The permittee shall maintain the records specified in paragraphs a. and b. below, for each product class. The permittee shall also maintain the records related to the initial determination of the percent epoxide emission reduction specified in paragraphs c. through j. below, as applicable, for each product class.

- a. Operating conditions of the product class, including:
 - i. Pressure decay curve;
 - ii. Minimum reaction temperature;
 - iii. Number of hydrogen atoms in the raw material;
 - iv. Minimum catalyst concentration;
 - v. Ratio of Ethylene Oxide/Propylene Oxide at the end of the epoxide feed; and
 - vi. Reaction conditions, including the size of the reactor or batch.

- b. A listing of all products in the product class, along with the information specified in paragraphs a.i. through a.vi. of this section, for each product.
- c. The concentration of epoxide at the end of the epoxide feed, determined in accordance with 40CFR§63.1427(b)(1).
- d. The concentration of epoxide at the onset of the ECO, determined in accordance with 40CFR§63.1427(c).
- e. The uncontrolled epoxide emissions at the onset of the ECO, determined in accordance with 40CFR§63.1427(c)(1). The records shall also include all the background data, measurements, and assumptions used to calculate the uncontrolled epoxide emissions.
- f. The epoxide emissions at the end of the ECO, determined in accordance with 40CFR§63.1427(d)(1). The records shall also include all the background data, measurements, and assumptions used to calculate the epoxide emissions.
- g. The percent epoxide reduction for the batch cycle, determined in accordance with 40CFR§63.1427(e)(1). The records shall also include all the background data, measurements, and assumptions used to calculate the epoxide emissions.
- h. The parameter level, established in accordance with 40CFR§63.1427(i)(2).
- i. If epoxide emissions occur before the end of the ECO, the permittee shall maintain records of the time and duration of all such emission episodes that occur during the initial demonstration of batch cycle efficiency.

[40CFR§63.1427(j)(1), 45 CSR 34, 45CSR13, Permit Number R13-1517, Condition 4.4.7., Equipment ID (8400)]

- 5.4.7. The permittee shall maintain the following records for each batch cycle: the product being produced and the product class to which it belongs, and a record of the value of the parameter monitored in accordance with Section 5.2.2. In addition, if epoxide emissions occur before the end of the ECO, the permittee shall maintain records of the time and duration of all such emission episodes.

[40CFR§63.1427(j)(2), 45 CSR 34, 45CSR13, Permit Number R13-1517, Condition 4.4.8., Equipment ID (8400)]

- 5.4.8. The permittee shall maintain records of all monitoring data required by Section 5.2.3 documenting the date and time of each visible emission check, the emission point or equipment/source identification number, the name or means of identification of the observer, the results of the check(s), whether the visible emissions are normal for the process, and, if applicable, all corrective measures taken or planned. An example form is supplied as Appendix A of R13-1517. Should a visible emission observation be required to be performed per the requirements specified in 45CSR7A, the data records of each observation shall be maintained per the requirements of 45CSR7A. For an emission unit out of service during the normal monthly evaluation, the record of observation may note “out of service” (O/S) or equivalent.

[45CSR13, Permit Number R13-1517, Condition 4.4.9., Emission Point ID (T-8706)]

- 5.4.9. **MON MACT.** The permittee shall keep record of tank truck inspections used to ship TR020/GR-7M Decant (Group 1 Wastewater) to off-site disposal.

[45CSR34, 40 C.F.R. §~~63.2470(e)~~63.148(b)(3), ~~§63.1253(f)~~; Wastewater Stream (TR020/GR-7M Decant)]

5.4.10. **MON MACT.** The permittee shall maintain the applicable records for compliance with the MON as specified by 40 C.F.R. §63.2525. Therefore, the permittee shall maintain the following records to demonstrate compliance with the MON requirements and this permit.

- Maintain supporting information used to determine MON initial applicability to process vents, storage vessels, equipment leaks, transfer operations, heat exchangers, process wastewater and in-process aqueous liquid streams.
- Maintain operating scenarios and calculations of uncontrolled hazardous air pollutant emissions for process vents used to prepare the NOCS.
- Maintain documentation of total source effectiveness (TRE) index determination for the Surfactant Recovery Column (Eq. Id. 8101).
- Maintain records of monitoring and inspections results required by 40CFR63, Subpart H for equipment component leak detection and repair.
- Maintain records of visual inspections conducted for tank trucks that are used to ship TR-020/GR-7M Decant to off-site locations.
- Maintain a record of each off-site shipment of wastewater stream TR020/GR-7M Decant.
- Maintain a record each time a safety device is opened to the air that contains hazardous air pollutants to avoid unsafe conditions.
- Maintain a copy of the following reports and notifications:
 - Notice of initial notification
 - Notification of compliance status report
 - Semiannual compliance reports including information regarding process changes as specified by §63.2520(e)(10).

[45CSR34, 40C.F.R.§63.2525]

5.4.11. For pressure relief devices in organic HAP service subject to condition 5.1.16 keep records of each pressure release to the atmosphere, including the following information:

- a. The source, nature, and cause of the pressure release.
- b. The date, time, and duration of the pressure release.
- c. The quantity of total HAP emitted during the pressure release and the calculations used for determining this quantity.
- d. The actions taken to prevent this pressure release.
- e. The measures adopted to prevent future such pressure releases.

[45CSR34 and 40CFR§63.1439(d)(10)(v)]

5.5. Reporting Requirements

- 5.5.1. On a semi-annual basis, the permittee shall report the emission rates of ethylene oxide and propylene oxide, from process vents, as calculated by computer simulation (adjusted if necessary to reflect any changes required by more recent or accurate stack test data) based on actual production data.

[45CSR13, Permit Number R13-1517, Condition 4.5.1., Emission Point ID (E-1081-3)]

- 5.5.2. The permittee, on a semi-annual basis, shall file reports which identify all periods of time during which compliance was not achieved with the operating parameters shown in Section 5.2.1 above. Such reports shall be certified to be accurate and true by a corporate official or his or her designee and filed within sixty (60) days of the end of each semi-annual reporting period. In any such aforementioned period of time, the permittee shall provide information detailing reasons for such excursions and corrective action taken. If there are periods of non-compliance, the report shall so certify. The report(s) may be submitted as part of the Title V semi-annual periodic report.

[45CSR13, Permit Number R13-1517, Condition 4.5.2., Equipment ID (C-8110, C-8130)]

- 5.5.3. The permittee shall submit semi-annual Periodic Reports as specified in paragraphs a. through f. of this section. Each report shall be submitted no later than sixty (60) days after the end of each six-month period.

The semi-annual Periodic Report shall cover the preceding six-month period. This report may be submitted as part of the Title V semi-annual periodic report.

- a. For equipment leaks, the permittee shall submit the information specified in 40CFR§63.1434(f).
- b. Reports of each batch cycle for which an ECO excursion occurred, as defined in 40CFR§63.1427(i)(3).
- c. Notification of each batch cycle when the time and duration of epoxide emissions before the end of the ECO, recorded in accordance with Section 5.4.7., exceed the time and duration of the emission episodes during the initial epoxide emission percentage reduction determination, as recorded in Section 5.4.6.h.
- d. If any performance tests are reported in a Periodic Report, the following information shall be included:
 - i. One complete test report shall be submitted for each test method used for a particular kind of emission point tested. A complete test report shall contain the information specified in 40CFR§63.1439(e)(5)(i)(B).
 - ii. For additional tests performed for the same kind of emission point using the same method, results and any other information required by the test method to be in the test report shall be submitted, but a complete test report is not required.
- e. The results for each change made to a primary product determination for a PMPU made under 40CFR§63.1420(e)(3) or (10).
- f. The results for each reevaluation of the applicability of 40CFR63 Subpart PPP to a storage vessel that begins receiving material from (or sending material to) a process unit that was not included in the initial determination, or a storage vessel that ceases to receive material from (or send material to) a process unit that was included in the initial determination, in accordance with 40CFR§63.1420(f)(8).

[45CSR13, Permit Number R13-1517, Condition 4.5.3., Equipment ID (8400)]

- 5.5.4. The permittee shall comply with the reporting requirements of 40CFR§63.1427(l) – “New polyether polyol products” and 40CFR§63.1427(m) – “Polyether polyol product changes”.

[45CSR13, Permit Number R13-1517, Condition 4.5.4., Equipment ID (8400)]

- 5.5.5. The permittee shall submit semi-annual monitoring reports for equipment components subject to the LDAR requirements of 45CSR§21-37 covered under Section 5.1.6. These reports may be submitted on the same schedule as the reports provided per Section 5.5.3. Semi-annual monitoring reports provided per Section 5.5.3, and required by 40CFR Part 63, Subpart PPP, will satisfy the equipment leak monitoring reports required by 45CSR27.
[45CSR13, Permit Number R13-1517, Condition 4.5.5., Equipment (all in VOC service)]
- 5.5.6. Any violation(s) of the allowable visible emission requirement for any emission source discovered during observations using 45CSR7A must be reported in writing to the Director of the Division of Air Quality as soon as practicable, but within ten (10) calendar days, of the occurrence and shall include, at a minimum, the following information: the results of the visible determination of opacity of emissions, the cause or suspected cause of the violation(s), and any corrective measures taken or planned.
[45CSR13, Permit Number R13-1517, Condition 4.5.6.]
- 5.5.7. The permittee shall comply with the reporting requirements for polyether polyol product manufacturing units as provided by §63.1439(e)(6)(i) through (viii).
[45CSR34 and 40CFR§63.1439(e)(6), Emission Unit ID (8400)]
- 5.5.8. **MON MACT.** The permittee shall comply with the applicable reporting requirements of the MON (40 C.F.R. §63, Subpart FFFF) in accordance with 40 C.F.R. §63.2520. As a result, the permittee shall submit a semiannual compliance report that includes the information specified by 63.2525(e) and the results of equipment leak monitoring and repair conducted per 40 C.F.R. 63, Subpart H.
[45CSR34, 40 C.F.R. §63.2520(e)]
- 5.5.9. For existing and new affected sources covered by 40 C.F.R. 63, Subpart PPP, a Notification of Compliance Status shall be submitted no later than August 24, 2017. For equipment leaks subject to 40CFR§63.1434, the permittee shall submit the information specified in the HON equipment leak Notification of Compliance Status requirements in 40CFR§63.182(c), in the Notification of Compliance Status required by this condition. For pressure relief devices subject to the requirements condition 5.1.16, the permittee shall submit the information required in Condition 5.5.10 in the Notification of Compliance Status no later than August 24, 2017.
[45CSR34 and 40CFR§63.1439(e)(5)]
- 5.5.10. For pressure relief devices in organic HAP service covered by 40CFR63, Subpart PPP, a description of the device or monitoring system to be implemented, including the pressure relief devices and process parameters to be monitored (if applicable), a description of the alarms or other methods by which operators will be notified of a pressure release, and a description of how the owner or operator will determine the information to be recorded under condition 5.4.11 (i.e., the duration of the pressure release and the methodology and calculations for determining of the quantity of total HAP emitted during the pressure release).
[45CSR34 and 40CFR§63.1439(e)(5)(viii)]

6.0. Source-Specific Requirements for [Middle Island Groundwater Containment System (MIGCS1 and MIGCS2)]

6.1. Limitations and Standards

6.1.1. The permittee shall comply with the following requirements for the Middle Island Groundwater Containment System (MIGCS):

a. The average total volatile organic hazardous air pollutant (VOHAP) concentration of the contaminated groundwater entering the system shall not exceed 500 ppmw on a 12-month basis. The frequency of sampling and analysis used to determine compliance with this limitation shall be conducted in accordance with Condition 6.2.1.

[40CFR§§63.7886(b)(2) and 63.7943(b)(1)(ii), 45CSR34]

b. The total VOHAP material contained in the contaminated groundwater entering the MIGCS shall not exceed a 12-month rate of 65.82 tons with no individual hourly average flowrate of water greater than 100 gpm. Should the total average VOHAP concentration be less than 300 ppmw and the stated maximum volumetric flowrate is not exceeded, this condition is satisfied.

c. The oil/water separator, sump pump, cascade aerator, flocculation & flash mixing tanks, clarifier, siphon tank, and vertical flow vegetated contact beds of the MIGCS shall each be covered and equipped with a vent that routes all vapors and gases from these pieces of equipment through a closed-vent system to the CATOX or GAC. This closed-vent system shall be continuously operated and maintained whenever gases or vapor containing HAPs are emitted from the identified sources in accordance with the following standards:

i. The closed-vent system for the CATOX shall be designed to operate at a pressure below atmospheric pressure. The system shall be equipped with at least one pressure gauge or other pressure measurement device that can be read from a readily accessible location to verify that negative pressure is being maintained in the closed-vent system when the control device is operating. Location of the instrument shall take into consideration the combustion air intake for the CATOX to ensure that measurement is representative of the whole closed vent system.

ii. The closed-vent system for the GAC shall be designed to operate with no detectable organic emissions using the procedure specified in 40 C.F.R. §63.694(k) and monitoring as specified in 40 C.F.R. §63.7928(b)(1).

[40CFR§63.7882, §63.7890, §63.694(k), §63.7928(b)(1) 45CSR34]

d. The horizontal contact beds of the MIGCS shall not receive any contaminated groundwater with a VOHAP concentration of 500 ppmw or greater. Compliance with this limit is satisfied by complying with Condition 6.1.1.a.

[40CFR§63.7886(b)(2), 45CSR34]

e. The Cascade Aerator shall be optimized to minimize the amount of VOHAP being stripped out of the groundwater with a flow rate of no greater than 475 standard cubic feet per minute.

f. All transfer systems associated with the MIGCS separator shall satisfy the general requirements of Subpart GGGGG to Part 63 by complying with the VOHAP concentration of Condition 6.1.1.a.

[40CFR§63.7882, §63.7886(b)(2), 45CSR34]

- g. The container(s) used to hold the oil from oil/water separator shall satisfy the general requirements of Subpart GGGGG to Part 63 by complying with the VOHAP concentration of Condition 6.1.1.a.
[40CFR§63.7882, §63.7886(b)(2), 45CSR34]
- h. If the concentration of VOHAP in the outlet of the of the horizontal contact beds of the MIGCS is equal to or greater than 10 ppmw, then the permittee shall meet the requirements of 40CFR§63.7936(b) and record the name, street address, and telephone number of the facility that the outflow was transferred to.
[40CFR§63.7936(a), 45CSR34]
- i. If the concentration of VOHAP in the collected liquid (oil) from the oil/water separator is equal to or greater than 10 ppmw and is transferred to another facility, then the permittee shall meet the requirements of 40CFR§63.7936(b) and record the name, street address, and telephone number of the facility that the VOHAP material was transferred to.
[40CFR§63.7936(a), 45CSR34]
- j. The permittee must develop and make available for inspection, upon request, a site-specific monitoring plan for the system used to measure and record the outlet temperature of the catalyst bed of the CATOX and to monitor the concentration of organic compounds in the exhaust vent stream of the GAC and any other monitoring system required by Subpart GGGGG to Part 63 that must address the following:
- i. Installation of the continuous monitoring system at a measurement location relative to each affected process unit such that the measurement is representative of control of the exhaust emissions (e.g., on or downstream of the last control device).
 - ii. Performance and equipment specifications for the sample interface, the pollutant concentration or parametric signal analyzer, and the data collection and reduction system.
 - iii. Performance evaluation procedures and acceptance criteria (e.g., calibrations).
 - iv. Ongoing operation and maintenance procedures according to the general requirements of 40 §§63.8(c)(1) (ii), (3), (4)(ii), (7), and (8).
 - v. Ongoing data quality assurance procedures according to the general requirements of §63.8(d) except for the requirements related to startup, shutdown, and malfunction plans referenced in § 63.8(d)(3). The permittee shall keep these written procedures on record for the life of the affected source or until the affected source is no longer subject to the provisions of this part, to be made available for inspection, upon request, by the Administrator. If the performance evaluation plan is revised, the permittee shall keep previous (*i.e.*, superseded) versions of the performance evaluation plan on record to be made available for inspection, upon request, by the Administrator, for a period of 5 years after each revision to the plan. The program of corrective action should be included in the plan required under § 63.8(d)(2).
 - vi. Ongoing recordkeeping and reporting procedures according to the general requirements of 40CFR §63.10(c)(1) through (14), (e)(1), and (e)(2)(i).
[40CFR§63.7935(g) and (h), 45CSR34]
- k. The permittee must be in compliance with the emissions limits, including the average daily temperature limit of Condition 6.1.2.i.ii., and the work practice standards in Subpart GGGGG of Part 63 at all times.
[40CFR§63.7935(a), 45CSR34]

[45 CSR 13, R13-3308, 4.1.1.]

- 6.1.2. The permittee shall operate and maintain the control devices CATOX and GAC, for the MIGCS unit in accordance with the following emission limitations and operating parameters.
- a. Emissions of VOC from MIGCS shall not exceed 0.65 pounds per hour. Combined annual VOC emissions from the CATOX and GAC shall not exceed 1.85 tons per year.
 - b. Total hazardous air pollutants (HAPs) from both the CATOX and the GAC shall not exceed 0.69 pounds per hour. Combined annual HAP emissions from the CATOX and GAC shall not exceed 1.92 tons per year.
 - c. Emissions of NO_x from MIGCS shall not exceed 0.01 pounds per hour. Annual NO_x emissions from the CATOX shall not exceed 0.04 tons per year.
 - d. Emissions of CO from MIGCS shall not exceed 0.01 pounds per hour. Annual CO emissions from the CATOX shall not exceed 0.04 tons per year.
 - e. Particulate matter emissions from the CATOX shall not exceed 0.01 pounds per hour. Compliance with this limit is satisfied by complying with the requirements of Condition 6.1.2.i.i.
[45 CSR §6-4.1.]
 - f. The effluent routed to either the CATOX or GAC shall not contain hydrogen sulfide greater than 50 grains per 100 cubic feet of gas. Compliance with this limit shall be satisfied by demonstrating that the concentration of hydrogen sulfide in the contaminated groundwater entering the MIGCS is less than 20 ppm by weight of hydrogen sulfide.
[45 CSR §10-5.1.]
 - g. Emission of Visible Particulate Matter. No person shall cause or allow emission of smoke into the atmosphere from any incinerator which is twenty percent (20%) opacity or greater.
[45 CSR §6-4.3]
 - h. The provisions of item g of this condition (45 CSR §6-4.3.) shall not apply to smoke which is less than forty percent (40%) opacity, for a period or periods aggregating no more than eight (8) minutes per start-up, or six (6) minutes in any sixty (60)-minute period for stoking operations.
[45 CSR §6-4.4.]
 - i. The permittee shall operate and maintain both the CATOX and GAC in a manner to achieve a minimum, 95% destruction efficiency for VOCs and volatile HAPs or an outlet concentration of TOC (minus methane and ethane) to 20 ppm by weight or less. Such proper operation of the control device shall constitute the following:
 - i. CATOX shall not exhibit any visible emissions for any duration greater than 5 minutes within a two (2) hour period.
 - ii. During periods of CATOX operation, the permittee shall operate the CATOX (when VOCs/HAPs are present in the process vent gas) with the daily average outlet temperature at or above the minimum outlet temperature established during the most recent performance testing or design evaluation.
[40CFR§63.7925(g)(5), 45CSR34]
 - iii. The permittee shall replace the existing catalyst bed with a bed that meets replacement specifications before the age of the bed exceeds the maximum allowable age established in the design evaluation or during performance test.
[40CFR§63.7925(i)]

- iv. The actual flowrate of effluent to CATOX shall not exceed 1,000 standard cubic feet per minute, which is the maximum flowrate rated by the manufacturer.
- v. The permittee shall immediately replace the carbon in the GAC control device when the monitoring device indicates breakthrough has occurred according to the requirements of 40 C.F.R. §63.693(d)(4)(iii)(A), which are based on organic compound concentrations in the exhaust gas and must follow the disposal requirements for spent carbon in 40 C.F.R. §63.693(d)(4)(ii).
[45CSR34, 40CFR§§63.7925(h)(3)(i) and (ii)]
- j. Whenever gases or vapors containing HAP are vented through the closed-vent system to CATOX and GAC, the CATOX and GAC must be operating.
[45CSR13, R13-3308, 4.1.2., 45CSR34, 40CFR§§63.7925(a), and (b)(2)]

6.1.3. **Operation and Maintenance of Air Pollution Control Equipment.** The permittee shall, to the extent practicable, install, maintain, and operate all pollution control equipment listed in Section 1.0 (MIGCS CO) and associated monitoring equipment in a manner consistent with safety and good air pollution control practices for minimizing emissions, or comply with any more stringent limits set forth in this permit or as set forth by any State rule, Federal regulation, or alternative control plan approved by the Secretary.
[45CSR13, R13-3308, 4.1.3. and 45CSR§13-5.10.]

6.2. Monitoring Requirements

- 6.2.1. For the purposes of demonstrating compliance with Condition 6.1.1.a., the permittee shall determine the average total VOHAP concentration of a remediation material using direct measurement in accordance with the following.
 - The 1st average period after initial startup of the MIGCS, average total VOHAP concentration shall be conducted and determined in accordance with Schedule No. 1 outlined in Table 6.2.1.
 - Thereafter, the following schedule is determined based on previous average total VOHAP concentration as outlined in Table 6.2.1:

Schedule No.	Criteria of Schedule* (ppmw)	Minimum No. Samples Required for the 12-month average	Timing of sampling
1	Above 400	12	Monthly
2	At 400 and above 240	6	Bi-monthly
3	Less than 240	4	Quarterly

**Criteria of Schedule is the average VOHAP concentration of the previous averaging period.*

The permittee shall use the following procedures:

- a. **Sampling.** Samples of each material stream must be collected from the container, pipeline, or other device used to deliver each material stream prior to entering the remediation material management unit or treatment process in a manner such that volatilization of organics contained in the sample is minimized and an adequately representative sample is collected and maintained for analysis by the selected method.
 - i. The monthly averaging period to be used for determining the average total VOHAP concentration for the material stream on a mass-weighted average basis must be designated and recorded.

- ii. No less than four samples must be collected to represent the complete range of HAP compositions and HAP quantities that occur in each material stream during the entire averaging period due to normal variations in the material stream(s). Examples of such normal variations are variation of the HAP concentration within a contamination area.
 - iii. All samples must be collected and handled according to written procedures you prepare and documented in a site sampling plan.
 - iv. This plan must describe the procedure by which representative samples of the material stream(s) are collected such that a minimum loss of organics occurs throughout the sample collection and handling process and by which sample integrity is maintained. A copy of the written sampling plan must be maintained on site in the facility operating records. An example of an acceptable sampling plan includes a plan incorporating sample collection and handling procedures according to the guidance found in “Test Methods for Evaluating Solid Waste, Physical/Chemical Methods,” EPA Publication No. SW-846 or Method 25D in 40CFR part 60, Appendix A.
- b. Analysis. Each collected sample must be prepared and analyzed according to either one of the methods listed in 40CFR§63.694(b)(2)(ii), or any current EPA Contracts Lab Program method (or future revisions) capable of identifying all the HAP in Table 1 of Subpart GGGG of Part 63.
- c. Calculations. The average total VOHAP concentration (\bar{C}) on a mass-weighted basis must be calculated by using the results for all samples analyzed according to item b of this condition and Equation 6.2.1.c. as follows:

$$\bar{C} = \frac{1}{Q_T} \times \sum_{i=1}^n (Q_i \times C_i) \text{ (Equation 6.2.1.c.)}$$

Where:

\bar{C} = Average VOHAP concentration of the material on a mass-weighted basis, ppmw.

i = Individual sample “i” of the material.

n = Total number of samples of the material collected (at least 4 per stream) for the averaging period (not to exceed 1 year).

Q_i = Mass quantity of material stream represented by C_i , kilograms per hour (kg/hr).

Q_T = Total mass quantity of all material during the averaging period, kg/hr.

C_i = Measured VOHAP concentration of sample “i” as determined according to the requirements of paragraph (b)(2) of this section, ppmw.

Records of such sampling and analysis shall be maintained in accordance with Condition 3.4.2.

[45CSR13, R13-3308, 4.2.1., 45CSR34, 40CFR§63.7943(b)]

- 6.2.2. For the purpose of demonstrating compliance with the maximum average limit in Condition 6.1.1.b., the permittee shall install and maintain a volumetric flow measuring device that measures flowrate entering the MIGCS and shall record the instance that the hourly flow rate is greater than 100 gpm. The permittee shall maintain records of date, time, duration, cause, and corresponding corrective action taken or implemented as result of each exceedance in accordance with Condition 3.4.2.
[45CSR13, R13-3308, 4.2.2.]

- 6.2.3. The permittee shall install, maintain, and continuously operate a continuous parametric monitoring system (CPMS) that measures and records the temperatures at the outlet of the catalyst bed for the purpose of determining the daily average temperature of the catalyst bed of the CATOX. The CPMS shall complete a minimum of one cycle of operation for each successive 15-minute period.

To calculate a valid hourly value, the permittee must have at least three of four equally spaced data values (or at least two, if that condition is included to allow for periodic calibration checks) for that hour from a CPMS that is not out of control according to the monitoring plan referenced in 40CFR§63.7935.

CPMS must determine the hourly average of all recorded readings and daily average except for monitor malfunctions, associated repairs, and required quality assurance or control activities (including, as applicable, calibration checks and required zero and span adjustments). These hourly temperature readings shall be used to determine the hourly and daily average temperature of the catalyst bed. Records of such every reading, calculations used to determine the hourly average, daily average temperature, inspection, calibration, and validation check shall be maintained in accordance with Condition 3.4.2.

The permittee shall conduct a performance evaluation on the CPMS according to the requirements in 40CFR §63.8(e) and site-specific monitoring plan as required in Condition 6.1.1.j.

[45CSR13, R13-3308, 4.2.3., 40CFR§63.7927(f), §§63.7935(i) and (j), §63.7945, §63.7946, §63.7952(b), §63.7952(c), 45CSR34]

- 6.2.4. For the purpose of demonstrating proper operation of the CATOX as set forth in Condition 6.1.2.i.i., the permittee shall:

- a. Conduct Method 22 visible emission observations for a minimum of ten (10) minutes per observation in accordance with the following schedule with the initial observations after startup of the CATOX using Schedule 1.

Table 6.2.4.a. – Method 22 Observation Schedule		
Schedule No.	Frequency of Observations	Minimum No of days between Observations (days)
1	Monthly	20
2	Quarterly	60
3	Annually	270

- b. After three (3) consecutive observations with no visible emissions observed, the permittee may change the frequency of the observations to the next Schedule No. as listed in Table 6.2.4.a.
- c. In the event visible emissions are observed, the permittee shall take immediate corrective action to resolve the issue with the CATOX or ensure the device is operating in accordance with the manufacturer’s written procedures. After observing visible emissions, the schedule of conducting observation shall reset back to Schedule No. 1. Records of such monitoring and repair activities shall be maintained in accordance with Condition 3.4.2.

[45CSR13, R13-3308, 4.2.4.]

- 6.2.5. For the purposes of demonstrating compliance with the requirements of the closed vent system in Condition 6.1.1.c.i., the permittee shall conduct the following activities:
- a. The permittee shall visually inspect the closed-vent system to check for defects that could result in air emissions. Defects include, but are not limited to, visible cracks, holes, or gaps in ductwork or piping; loose connections; or broken or missing caps or other closure devices.
 - b. The permittee must perform an initial inspection following installation of the closed-vent system. Thereafter, the permittee must perform the inspection at least once every calendar year.
 - c. In the event that a defect is detected, the permittee shall repair the defect in accordance with the requirements of Conditions 6.2.5.d.
 - d. The permittee shall make first efforts at repair of the defect no later than 5 calendar days after detection and repair shall be completed as soon as possible but no later than 45 calendar days after detection.
 - e. Repair of a defect may be delayed beyond 45 calendar days if either of the conditions specified in the following sub-item (e.i. or e.ii.) occurs. In this case, the permittee must repair the defect the next time the process or unit that vents to the closed-vent system is shutdown. Repair of the defect must be completed before the process or unit resumes operation.
 - i. Completion of the repair is technically infeasible without the shutdown of the process or unit that vents to the closed-vent system.
 - ii. The permittee determines that the air emissions resulting from the repair of the defect within the specified period would be greater than the fugitive emissions likely to result by delaying the repair until the next time the process or unit that vents to the closed-vent system is shutdown.
 - f. The permittee shall maintain a record of the inspection and repairs in accordance with Condition 3.4.2. **[45CSR13, R13-3308, 4.2.5, 40CFR§63.7928(b)(2), 40CFR§§63.695(c)(2) and (c)(3), §63.696]**
- 6.2.6. For the purposes of demonstrating compliance with Condition 6.1.1.h., the permittee shall sample and analyze to determine the average total VOHAP concentration of the outlet stream from the MIGCS in accordance with 40CFR§63.7943. Such sampling and analysis shall be conducted in accordance with the appropriate procedures outlined in Condition 6.2.1. Records of such sampling and analysis shall be maintained in accordance with Condition 3.4.2. **[45CSR13, R13-3308, 4.2.6, 40CFR§63.7936(a), §63.7940(c), 45CSR34]**
- 6.2.7. For the purposes of demonstrating compliance with Condition 6.1.2.f., the permittee shall sample and analyze the inlet of the MIGCS within 12 months after startup of the MIGCS to determine the concentration of hydrogen sulfide. Should concentration of hydrogen sulfide be detected above 1.0 ppm, the permittee shall repeat such demonstration on an annual basis thereafter. Such sampling and analysis shall be conducted in accordance with the appropriate procedures outlined in Condition 6.2.1. Records of such sampling and analysis shall be maintained in accordance with Condition 3.4.2. **[45CSR13, R13-3308, 4.2.7]**
- 6.2.8. For the purposes of demonstrating compliance with the requirements of the closed vent system in Condition 6.1.1.c.ii, the Permittee shall conduct the following:
- a. Conduct an initial inspection for initial compliance of 6.1.1.c.ii within 180 days of start-up of the MIGCS. This inspection shall be conducted using procedures outlined in 40 C.F.R. §63.694(k) and Method 21 of 40 C.F.R. Part 60, Appendix A.
 - b. After conducting the initial inspection:

- i. Closed-vent system joints, seams, or other connections that are permanently or semi-permanently sealed (e.g. a welded joint between two sections of hard piping or a bolted and gasketed ducting flange) shall be visually inspected at least once per year to check for defects that could result in air emissions. The permittee shall monitor a component or connection using the procedures specified in 40 C.F.R. §63.694(k) to demonstrate that it operates with no detectable organic emissions following any time the component is repaired or replaced (e.g. a section of damaged hard piping is replaced with new hard piping) or the connection is unsealed (e.g. a flange is unbolted).
- ii. Closed-vent system components or connections other than those specified in 6.2.8.b.i, shall be monitored at least once per year using the procedures specified in 40CFR§63.694(k) to demonstrate that components or connections operate with no detectable organic emissions.
- c. In the event that a defect is detected, the permittee shall repair the defect in accordance with the requirements of 6.2.8.d.
- d. The permittee shall make first efforts at repair of the defect no later than 5 calendar days after detection, and repair shall be completed as soon as possible but no later than 45 calendar days after detection.
- e. Repair of a defect may be delayed beyond 45 calendar days if either of the conditions specified in the following sub-item (e.i or e.ii) occurs. In this case, the permittee must repair the defect the next time the process or unit that vents to the closed-vent system is shutdown. Repair of the defect must be completed before the process or unit resumes operation.
 - i. Completion of the repair is technically infeasible without the shutdown of the process or unit that vents to the closed-vent system.
 - ii. The permittee determines that the air emissions resulting from the repair of the defect within the specified period would be greater than the fugitive emissions likely to result by delaying the repair until the next time the process or unit that vents to the closed-vent system is shutdown.
- f. The permittee shall maintain a record of the inspection and repairs in accordance with Condition 3.4.2.

[45CSR34, 45CSR13, R13-3308, 4.2.8, 40CFR§§63.7928(b)(1) and (b)(4), §63.694(k), §§63.695(c)(1)(ii) and (c)(3)]

6.2.9. For GAC, you must monitor the concentration of organic compounds in the exhaust vent system according to the requirements in 40 C.F.R. §63.693(d)(4)(iii)(A).

[45CSR34, 45CSR13, R13-3308, 4.2.9, 40CFR§63.7927(c)]

6.2.10. For GAC, the Permittee must demonstrate continuous compliance with the spent carbon replacement and disposal work practice standards for nonregenerable carbon adsorption systems in 40 C.F.R. §63.7925(h)(3) by meeting the requirements in Conditions 6.2.10.a through c.

- a. Monitoring the concentration level of the organic compounds in the exhaust vent for the carbon adsorption system as required in 40 C.F.R. §63.7927(c), immediately replacing the carbon in the control device when breakthrough is indicated by the monitoring device, and recording the date of breakthrough and carbon replacement. Or, the Permittee must replace the carbon in the control device at regular intervals and record the date of carbon replacement.
- b. Follow the disposal requirements for spent carbon in 40CFR§63.693(d)(4)(ii).
- c. Keep records to document compliance with the requirements of the work practice standards.

[45CSR34, 40 C.F.R. §63.7928(g)]

6.3. Testing Requirements

- 6.3.1. For the purposes of demonstrating compliance with the VOC and total HAP emission limits of Condition 6.1.2., the permittee shall demonstrate compliance with the destruction efficiency requirement of the CATOX in Condition 6.1.2.i. and to establish the daily average temperature of the catalyst bed in Condition 6.1.2.i.ii., the permittee shall conduct an initial performance test within 180 days after initial startup of the MIGCS.

The permittee shall conduct a Method 18 of Appendix A to Part 60, which shall include all other reference methods needed to complete testing to determine if the CATOX is operating within compliance of Condition 6.1.2. During such testing, the MIGCS and CATOX must be operating in accordance with 40CFR§63.7(e)(1) and 40CFR§§63.7941(b)(1) through (b)(5). All operating parameters of the MIGCS and CATOX for each test run shall be recorded and included in the test report. Such demonstration shall be conducted in accordance with the applicable portions of Condition 3.3.1. Records of such demonstration shall be maintained in accordance with Condition 3.4.2.

[45CSR13, R13-3308, 4.3.1, 40CFR§63.7(a)(2) and (e)(1), 40CFR§63.7940(c), §63.7941, 45CSR34]

- 6.3.2. The permittee shall repeat the testing in Condition 6.3.1. within 90 days after determining the total average VOHAP concentration of is at or above a total VOHAP concentration of 400 ppmw or at any other time when the action is authorized by Section 114 of the Clean Air Act.

[45CSR13, R13-3308, 4.3.2, 40CFR§63.7942, and 40CFR§63.7(a)(3), 45CSR34]

- 6.3.3. For the purposes of demonstrating compliance with the VOC and total HAP emission limits of 6.1.2 during periods of GAC operation, the permittee shall conduct a design evaluation according to the general requirements in 40 C.F.R. §63.693(b)(8) and the specific requirements in 40 C.F.R. §63.693(d)(2)(ii).

The design analysis shall address the vent stream composition, constituent concentrations, flow rate, relative humidity, and temperature and shall establish the design exhaust vent stream organic compound concentration, carbon bed capacity, activated carbon type and working capacity, and design carbon replacement interval based on the total carbon working capacity of the control device and emission point operating schedule.

[45CSR34, 45CSR13, R13-3308, 4.3.3, 40CFR§63.7941(c) and §63.693(d)(2)(ii)(B)]

6.4. Recordkeeping Requirements

- 6.4.1. **Record of Maintenance of Air Pollution Control Equipment.** For all pollution control equipment listed in Section 1.0 (MIGCS CO), the permittee shall maintain accurate records of all required pollution control equipment inspection and/or preventative maintenance procedures.

[45CSR13, R13-3308, 4.4.2]

- 6.4.2. **Record of Malfunctions of Air Pollution Control Equipment.** For all air pollution control equipment listed in Section 1.0 (MIGCS CO), the permittee shall maintain records of the occurrence and duration of any malfunction or operational shutdown of the air pollution control equipment during which excess emissions occur. For each such case, the following information shall be recorded:

- a. The equipment involved.
- b. Steps taken to minimize emissions during the event.
- c. The duration of the event.
- d. The estimated increase in emissions during the event.

For each such case associated with an equipment malfunction, the additional information shall also be recorded:

- e. The cause of the malfunction.
- f. Steps taken to correct the malfunction.
- g. Any changes or modifications to equipment or procedures that would help prevent future recurrences of the malfunction.

[45CSR13, R13-3308, 4.4.3]

6.4.3. The permittee shall keep the following records:

- a. A copy of each notification and report that you submitted to comply with 40 C.F.R. part 63, subpart GGGGG, including all documentation supporting any Initial Notification or Notification of Compliance Status that you submitted, according to the requirements in 40 C.F.R. §§63.10(b)(1) and (b)(2)(xiv).
- b. Reinstate 6.4.3.b condition from current permit as it is present in 63.7952(a)(2).
- c. For each deviation from an emissions limitation (including an operating limit) or work practice standard occurring at an affected source, you must record information on the number of deviations. For each deviation, include the date, time, and duration, a list of the affected sources or equipment, an estimate of the quantity of each regulated pollutant emitted over any emission limit, a description of the method used to estimate the emissions, the actions taken to minimize emissions, the cause of the deviation (including unknown cause), as applicable, and the corrective actions taken to return the affected unit to its normal or usual manner of operation.
 - (i) For pressure tank closure devices, as specified in 40CFR§ 63.7895(d)(4), keep records of each release to the atmosphere, including the information specified in paragraphs (iii)(A) through (G) of this section.
 - (ii) For each closed vent system that includes bypass devices that could divert a stream away from the control device and into the atmosphere, as specified in 40CFR§ 63.7927(a)(2), and each open-ended valve or line in an emergency shutdown system which is designed to open automatically in the event of a process upset, as specified in 40CFR§ 63.1014(c) or 40CFR§ 63.1033(c), keep records of each release to the atmosphere, including the information specified in paragraphs (iii)(A) though (G) of this section.
 - (iii)
 - (A) The source, nature, and cause of the release.
 - (B) The date, time, and duration of the release.
 - (C) An estimate of the quantity of HAP listed in Table 1 of this subpart emitted during the release and the calculations used for determining this quantity.
 - (D) The actions taken to prevent this release.
 - (E) The measures adopted to prevent future such release.

(F) Hourly records of whether the bypass flow indicator specified under 40CFR§ 63.7927(a)(2)(i) was operating and whether a diversion was detected at any time during the hour, as well as records of the times of all periods when the vent stream is diverted from the control device or the flow indicator is not operating.

(G) Where a seal mechanism is used to comply with 40CFR§ 63.7927(a)(2)(ii), hourly records of flow are not required. In such cases, you must record that the monthly visual inspection of the seals or closure mechanism has been done and record the duration of all periods when the seal mechanism is broken, the bypass line valve position has changed, or the key for a lock-and-key type lock has been checked out, and records of any car-seal that has broken.

- h. A record of the fluid level at the beginning and end of each maintenance period during which the tank is subject to 40CFR§ 63.7925(b)(3).
- i. Results of performance tests and performance evaluations as required by 40CFR§ 63.10(b)(2)(viii).
- j. The records of initial and ongoing determinations for affected sources that are exempt from control requirements under this subpart.
- k. For each continuous monitoring system, you must keep the records as described in paragraphs (b)(1) and (2) of this section.
 - (1) Records described in 40CFR§ 63.10(b)(2)(vi) through (xi) that apply to your continuous monitoring system.
 - (2) Performance evaluation plans, including previous (i.e., superseded) versions of the plan as required in 40CFR§ 63.8(d)(3).
- l. You must keep the records required by this subpart to show continuous compliance with each emissions limitation, work practice standard, and operation and maintenance requirement that applies to you.
- m. You must record, on a semiannual basis, the information in 40CFR§ 63.696(g) for planned routine maintenance of a control device for emissions from process vents.
- o. Any records required to be maintained by this part that are submitted electronically via the EPA's CEDRI may be maintained in electronic format. This ability to maintain electronic copies does not affect the requirement for facilities to make records, data, and reports available upon request to a delegated air agency or the EPA as part of an on-site compliance evaluation.

[45CSR13, R13-3308, 4.4.4, 40 CFR §§63.7952(a)(1), (a)(3), (a)(7) through (a)(10), (b) through (e), 45CSR34]

- 6.4.4. The permittee shall record, on a semiannual basis, the information specified in the following paragraphs for planned routine maintenance operations that would prevent the CATOX or GAC from not being capable of meeting the requirements of Condition 6.1.2.i.
 - a. A description of the planned routine maintenance that is anticipated to be performed for the CATOX and GAC during the next 6 months. This description shall include the type of maintenance necessary, planned frequency of maintenance, and lengths of maintenance periods.
 - b. A description of the planned routine maintenance that was performed for the CATOX and GAC during the previous 6 months.

This description shall include the type of maintenance performed and the total number of hours during these 6 months that the CATOX or GAC did not meet the requirement of Condition 6.1.2.i., due to planned routine maintenance.

- c. The permittee shall maintain such information in accordance with Condition 3.4.2.
[45CSR13, R13-3308, 4.4.5, 40 CFR §63.7952(d), 40 CFR§63.696(g), 45CSR34]

6.5. Reporting Requirements

- 6.5.1. Any exceedance(s) of the allowable visible emission requirement for the CATOX discovered during observations using 40CFR Part 60, Appendix A, Method 9 shall be reported in writing to the Director of the Division of Air Quality as soon as practicable, but within ten (10) calendar days of the occurrence and shall include, at a minimum, the following information: the results of the visible determination of opacity of emissions, the cause or suspected cause of the violation(s), and any corrective measures taken or planned.
[45CSR13, R13-3308, 4.5.1]
- 6.5.2. Before the close of business on the 60th calendar day following the completion of the initial testing as required in Condition 6.3.1., the permittee shall submit a Notification of Compliance Status (NOCS) of Subpart GGGGG to Part 63 according to 40 CFR §63.9(h)(2)(ii).
[45CSR13, R13-3308, 4.5.2, 40 CFR §63.7950(e)(1), 40 CFR §63.9(h)(2)(ii), and §63.10(d)(2), 45CSR34]
- 6.5.3. The permittee shall submit semiannual compliance report of Subpart GGGGG to the Director. The first compliance report must cover the period beginning on the compliance date that is specified for your affected source in 40 CFR §63.7883 and ending on June 30 or December 31, whichever date comes first after the compliance date that is specified for your affected source.
[40 CFR §63.7951(a), 45CSR34]

The first compliance report must be postmarked or delivered no later than the date established in permit condition 3.5.6. Each subsequent compliance report must cover the semiannual reporting period from January 1 through June 30 or the semiannual reporting period from July 1 through December 31.

Each subsequent compliance report must be postmarked or delivered in accordance with the timing established in the facility's Title V Operating Permit.
[40 CFR §63.7951(a)(5), 45CSR34]

Each compliance report must include the information specified in 40 CFR §§63.7951(b)(1) through (3) and, as applicable, 40 CFR §§63.7951 (b)(4) through (9).
[40CFR§63.7951(b), 45CSR34]
[45 CSR 13, R13-3308, 4.5.3]

7.0. Source-Specific Requirements [40CFR63, Subpart PPP “Polyether Polyols” MACT requirements for Oxide Adducts production units, Emission Point ID(s) (See Section 1.0 for Oxide Adducts Equipment List)]

7.1. Limitations and Standards

7.1.1. The permittee shall comply with all applicable requirements of 40 CFR 63 Subpart PPP “National Emission Standard for Hazardous Air Pollutants from Polyether Polyols Production”. The enumerated requirements that follow, address specific obligations taken from applicable sections of this regulation. However, the permittee shall comply with the Polyether Polyols Production MACT as referenced above in its entirety, which includes, but is not limited to the specific requirements listed within this section of the Title V permit.

7.1.2. The permittee shall comply with the standards established within 40CFR§63.1424, as follows:

(a) Except as provided under paragraph (b) of this section, the owner or operator of an existing or new affected source shall comply with the provisions in:

- (1) Sections 63.1425 through 63.1430 for process vents;
- (2) Section 63.1432 for storage vessels;
- (3) Section 63.1433 for wastewater;
- (4) Section 63.1434 for equipment leaks;
- (5) Section 63.1435 for heat exchangers;
- (6) Section 63.1437 for additional test methods and procedures;
- (7) Section 63.1438 for monitoring levels and excursions; and
- (8) Section 63.1439 for general reporting and recordkeeping requirements.

(b) When emissions of different kinds (i.e., emissions from process vents subject to §§63.1425 through 63.1430, storage vessels subject to §63.1432, process wastewater, and/or in-process equipment subject to §63.149) are combined, and at least one of the emission streams would require control according to the applicable provision in the absence of combination with other emission streams, the permittee shall comply with the requirements of either paragraph (b)(1) or (2) of this section.

- (1) Comply with the applicable requirements of this subpart for each kind of emission in the stream as specified in paragraphs (a)(1) through (5) of this section; or
- (2) Comply with the most stringent set of requirements that applies to any individual emission stream that is included in the combined stream, where either that emission stream would be classified as requiring control in the absence of combination with other emission streams, or the owner chooses to consider that emission stream to require control for the purposes of this paragraph.

[45CSR34 and 40CFR§63.1424]

7.1.3. Since the permittee uses epoxides in the production of polyether polyols the affected source is subject to 63.1425(b), process vent control requirements as follows:

(b) *Requirements for epoxide emissions.* The owner or operator of an existing affected source may comply with the requirement to reduce epoxide emissions by 98% from process vents by using extended cook-out.

[45CSR34 and 40CFR§63.1425(b)(2)(ii), Emission Unit IDs (R703, R704, R705, R706, R707, R708)]

- 7.1.4. It is important to note the exemption given to processes which employ extended cookout (ECO) from having to determine the uncontrolled organic HAP emissions, which is stated as follows:

(d) *Determination of uncontrolled organic HAP emissions.* For each process vent at a PMPU that is complying with the process vent control requirements in 40CFR§63.1425(b)(1)(i), (b)(1)(iii), (b)(2)(ii), (b)(2)(iv), (c)(1)(ii), or (d)(2) using a combustion, recovery, or recapture device, the permittee shall determine the uncontrolled organic HAP emissions in accordance with the provisions of this paragraph, with the exceptions noted in paragraph (d)(1) of this section. The provisions of §63.1427(c)(1) shall be used to calculate uncontrolled epoxide emissions prior to the onset of an extended cook out.

(1) *Exemptions.* The permittee is not required to determine uncontrolled organic HAP emissions for process vents as provided by 40CFR63.1426(d) because all process vents subject to the epoxide emission reduction requirements of §63.1425(b) are controlled at all times using extended cookout.

[45CSR34 and 40CFR§63.1426(d)(1)(i), Emission Unit IDs (R703, R704, R705, R706, R707, R708)]

- 7.1.5. The permittee shall determine the epoxide emission control efficiency for process vents subject to the epoxide emission reduction requirements of §63.1425(b) in accordance with §63.1427(e)

[45CSR34 and 40CFR§63.1426(e)(2)(iii), Emission Unit IDs (R703, R704, R705, R706, R707, R708)]

- 7.1.6. The permittee must conduct a design evaluation for the extended cookout control technique as presented in §63.1427(f)(2). The permittee is not required to conduct performance tests provided uncontrolled epoxide emissions prior to the end of ECO are less than 10 tons per year (9.1 mega grams per year). Per §63.1427(a)(2)(ii) uncontrolled epoxide emissions prior to ECO shall be determined by the procedures in §63.1427(d)(1). The design evaluation shall establish the minimum duration (time) of extended cookout.

[45CSR34 and 40CFR§63.1426(f)(1) & (2), (b)(6), (d)(1)(i), Emission Unit IDs (R703, R704, R705, R706, R707, R708)]

- 7.1.7. The remainder of the process vent requirements specific to ECO are listed within 63.1427 as follows:

(a) *Applicability of extended cookout requirements.* Owners or operators of affected sources that produce polyether polyols using epoxides, and that are using ECO as a control technique to reduce epoxide emissions in order to comply with percent emission reduction requirements in §63.1425(b)(1)(i) or (b)(2)(ii) shall comply with the provisions of this section.

(1) For each product class, the permittee shall determine the batch cycle percent epoxide emission reduction for the most difficult to control product in the product class, where the most difficult to control product is the polyether polyol that is manufactured with the slowest pressure decay curve.

(2) The permittee shall determine the batch cycle percent epoxide emission reduction by using process knowledge, reaction kinetics, and engineering knowledge, in accordance with §63.1427 (a)(2)(ii) and §63.1427(e).

(ii) The permittee must maintain uncontrolled epoxide emissions prior to the end of the ECO less than 10 tons per year (9.1 mega grams per year) as determined by the procedures in §63.1427(d)(1).

(d) *Determine emissions at the end of the ECO.* The permittee shall calculate the epoxide emissions at the end of the ECO, where the end of the ECO is defined as the point immediately before the time when the reactor contents are emptied and/or the reactor vapor space purged to the atmosphere or to a combustion, recovery, or recapture device.

(d)(1) The epoxide emissions at the end of the ECO shall be determined using Equation 9

$$E_{e,E} = (C_{liq,f})(V_{liq,f})(D_{liq,f}) + (C_{vap,f})(V_{vap,f})(D_{vap,f}) \quad \text{[Equation 9]}$$

Where:

$E_{e,E}$ = Epoxide emissions at the end of the ECO, kg.

$C_{liq,f}$ = Concentration of epoxide in the reactor liquid at the end of the ECO, determined in accordance with §63.1427 (f)(1) of this section, weight percent.

$V_{liq,f}$ = Volume of reactor liquid at the end of the ECO, liters.

$D_{liq,f}$ = Density of reactor liquid, kg/liter.

$C_{vap,f}$ = Concentration of epoxide in the reactor vapor space as it exits the reactor at the end of the ECO, determined in accordance with §63.1427 (f)(2), weight percent.

$V_{vap,f}$ = Volume of the reactor vapor space as it exits the reactor at the end of the ECO, liters.

$D_{vap,f}$ = Vapor density of reactor vapor space at the end of the ECO, kg/liter.

[45CSR34 and 40CFR§63.1427(a)(1) , (a)(2)(i), (a)(2)(ii), (d)(1), Emission Unit IDs (R703, R704, R705, R706, R707, R708)]

7.1.8. (b) *Define the end of epoxide feed.* The permittee shall determine the concentration of epoxide in the reactor liquid at the point in time when all epoxide has been added to the reactor and prior to any venting. This concentration shall be determined in accordance with the procedures in §63.1427(f)(1)(i).
[45CSR34 and 40CFR§63.1427(b)(1), Emission Unit IDs (R703, R704, R705, R706, R707, R708)]

7.1.9. (c) *Define the onset of the ECO.* The permittee shall calculate the uncontrolled emissions for the batch cycle by calculating the epoxide emissions, if any, prior to the onset of the ECO, plus the epoxide emissions at the onset of the ECO. The onset of the ECO is defined as the point in time when the combined unreacted epoxide concentration in the reactor liquid is equal to 25 percent of the concentration of epoxides at the end of the epoxide feed, which was determined in accordance with §63.1427(b)- Equation 8 as follows.

(1) The uncontrolled epoxide emissions for the batch cycle shall be determined using Equation 8.

$$E_{e,u} = (C_{liq,i})(V_{liq,i})(D_{liq,i}) + (C_{vap,i})(V_{vap,i})(D_{vap,i}) + (E_{epox,bef}) \quad \text{[Equation 8]}$$

Where:

$E_{e,u}$ = Uncontrolled epoxide emissions at the onset of the ECO, kilograms per (kg)/batch.

$C_{liq,i}$ = Concentration of epoxide in the reactor liquid at the onset of the ECO, which is equal to 25 percent of the concentration of epoxide at the end of the epoxide feed, determined in accordance with paragraph (b)(1) of this section, weight percent. Note: (f)(1) of this section is referenced by (b)(1) for determining epoxide concentration in the reactor liquid.

$V_{liq,i}$ = Volume of reactor liquid at the onset of the ECO, liters.

$D_{liq,i}$ = Density of reactor liquid, kg/liter.

$C_{vap,i}$ = Concentration of epoxide in the reactor vapor space at the onset of the ECO, determined in accordance with paragraph (f)(2) of this section, weight percent.

$V_{vap,i}$ = Volume of the reactor vapor space at the onset of the ECO, liters.

$D_{vap,i}$ = Vapor density of reactor vapor space at the onset of the ECO, kg/liter.

$E_{epox,bef}$ = Epoxide emissions that occur prior to the onset of the ECO, determined in accordance with the provisions of §63.1426(d), kilograms.

[45CSR34 and 40CFR§63.1427(c)(1), Emission Unit IDs (R703, R704, R705, R706, R707, R708)]

- 7.1.10. (d) *Determine emissions at the end of the ECO.* The permittee shall calculate the epoxide emissions at the end of the ECO, where the end of the ECO is defined as the point immediately before the time when the reactor contents are emptied and/or the reactor vapor space purged to the atmosphere or to a combustion, recovery, or recapture device.

(d)(1) The epoxide emissions at the end of the ECO shall be determined using Equation 9

$$E_{e,E} = (C_{liq,f})(V_{liq,f})(D_{liq,f}) + (C_{vap,f})(V_{vap,f})(D_{vap,f}) \quad \text{[Equation 9]}$$

Where:

$E_{e,E}$ = Epoxide emissions at the end of the ECO, kg.

$C_{liq,f}$ = Concentration of epoxide in the reactor liquid at the end of the ECO, determined in accordance with §63.1427 (f)(1) of this section, weight percent.

$V_{liq,f}$ = Volume of reactor liquid at the end of the ECO, liters.

$D_{liq,f}$ = Density of reactor liquid, kg/liter.

$C_{vap,f}$ = Concentration of epoxide in the reactor vapor space as it exits the reactor at the end of the ECO, determined in accordance with §63.1427 (f)(2), weight percent.

$V_{vap,f}$ = Volume of the reactor vapor space as it exits the reactor at the end of the ECO, liters.

$D_{vap,f}$ = Vapor density of reactor vapor space at the end of the ECO, kg/liter.

[45CSR34 and 40CFR§63.1427(d)(1), Emission Unit IDs (R703, R704, R705, R706, R707, R708)]

- 7.1.11. (e) *Determine percent epoxide emission reduction.* (1) The permittee shall determine the percent epoxide emission reduction for the batch cycle using Equation 10.

$$R_{batchcycle} = \left[\frac{E_{e,u} - (E_{e,E}) \left(1 - \frac{R_{addon,i}}{100} \right) - (E_{e,o}) \left(1 - \frac{R_{addon,j}}{100} \right)}{E_{e,u}} \right] * 100 \quad \text{[Equation 10]}$$

Where:

$R_{batchcycle}$ = Epoxide emission reduction for the batch cycle, percent.

$E_{e,E}$ = Epoxide emissions at the end of the ECO determined in accordance with paragraph (d)(1) of this section, kilograms.

$R_{addon,i}$ = Control efficiency of combustion, recovery, or recapture device that is used to control epoxide emissions after the ECO, determined in accordance with the provisions of §63.1426(c), percent.

$E_{e,o}$ = Epoxide emissions that occur before the end of the ECO, determined in accordance with the provisions of §63.1426(d), kilograms.

$R_{addon,j}$ = Control efficiency of combustion, recovery, or recapture device that is used to control epoxide emissions that occur before the end of the ECO, determined in accordance with the provisions of §63.1426(c), percent.

$E_{e,u}$ = Uncontrolled epoxide emissions determined in accordance with paragraph (c)(1) of this section, kilograms.

[45CSR34 and 40CFR§63.1427(e)(1), Emission Point IDs (E703, E704, E705, E706, E707, E708)]

- 7.1.12. (f) *Determination of epoxide concentrations.* The permittee shall determine the epoxide concentrations in accordance with the procedures in this paragraph.

(1) The permittee shall determine the concentration of epoxide in the reactor liquid using reaction kinetics in accordance with paragraph (f)(1)(ii) of 40CFR§63.1427 as listed by Equation 12 below. The permittee may also request to use an alternative methodology in accordance with paragraph (f)(1)(iii) of 40CFR§63.1427.

(ii) Determine the epoxide concentration in the reactor liquid using Equation 12. [Equation 12]

$$C_{liq,f} = C_{liq,i} e^{-kt} \quad [\text{Equation 12}]$$

$C_{liq,f}$ = Concentration of epoxide in the reactor liquid at the end of the time period, weight percent.

$C_{liq,i}$ = Concentration of epoxide in the reactor liquid at the beginning of the time period, weight percent.

k = Reaction rate constant, 1/hr.

t = Time, hours.

Note: This equation assumes a first order reaction with respect to epoxide concentration. where:

[45CSR34 and 40CFR§63.1427(f)(1)(ii), Emission Unit IDs (R703, R704, R705, R706, R707, R708)]

- 7.1.13. (f)(2) The permittee shall determine the concentration of epoxide in the reactor vapor space by engineering estimation in accordance with paragraph 40CFR§63.1427(f)(2)(ii) as follows.

ii) Determine the epoxide concentration in the vapor space using Raoult's Law or another appropriate phase equilibrium equation and the liquid epoxide concentration, determined in accordance with 40CFR§63.1427 (f)(1) of this section.

[45CSR34 and 40CFR§63.1427(f)(2)(ii), Emission Unit IDs (R703, R704, R705, R706, R707, R708)]

- 7.1.14. (g) *Determination of pressure.* The permittee shall determine the total pressure of the system using standard pressure measurement devices calibrated according to the manufacturer's specifications or other written procedures that provide adequate assurance that the equipment would reasonably be expected to monitor accurately.

[45CSR34 and 40CFR§63.1427(g) Emission Unit IDs (R703, R704, R705, R706, R707, R708)]

- 7.1.15. (h) *Determination if pressure decay curves are similar.* The permittee shall determine the pressure decay curve as defined in §63.1423. Products with similar pressure decay curves constitute a product class. To determine if two pressure decay curves are similar when the pressure decay curves for products have different starting and finishing pressures, the permittee shall determine the time when the pressure has fallen to half its total pressure by using Equation 13:

$$\text{Time } (P_{\text{half}} 1) - \text{Time } (P_{\text{half}} 2) < 20\% T_{\text{AVG}} \quad [\text{Equation 13}]$$

Where:

$P_{\text{half}1}$ = Half the total pressure of the epoxide for product 1.

Time ($P_{\text{half}1}$) = Time when the pressure has fallen to half its total pressure for product 1.

$P_{\text{half}2}$ = Half the total pressure of the epoxide for product 2.

Time ($P_{\text{half}2}$) = Time when the pressure has fallen to half its total pressure for product 2.

T_{AVG} = The average time to cookout to the point where the epoxide pressure is 25 percent of the epoxide pressure at the end of the feed step for products 1 and 2.

[45CSR34 and 40CFR§63.1427(h), Emission Unit IDs (R703, R704, R705, R706, R707, R708)]

- 7.1.16. The heat exchanger systems used in the Oxide Adducts Plant to cool process equipment or materials are exempt from the heat exchanger monitoring requirements of 40CFR§63.104(a) as long as the following conditions are maintained:
- (i). Uses intervening fluid with less than 5% HAPs between process and cooling water sides (reactors), or
 - (ii). Process side HAP concentration less than 5% (product treatment systems).
[45CSR34 and 40CFR§63.1435]
- 7.1.17. **Requirements for pressure relief devices covered by 40 CFR 63 Subpart PPP.** The permittee must comply with the operating and pressure release requirements specified in paragraphs (a) and (b) of this condition for pressure relief devices in organic HAP gas or vapor service. The permittee must also comply with the pressure release management requirements specified in paragraph (c) of this condition for all pressure relief devices in organic HAP service.
- a. Operating requirements. Except during a pressure release event, operate each pressure relief device in organic HAP gas or vapor service with an instrument reading of less than 500 ppm above background as detected by Method 21 of 40CFR part 60, appendix A.
 - b. Pressure release requirements. For pressure relief devices in organic HAP gas or vapor service, comply with the following requirements, as applicable.
 - 1. If the pressure relief device does not consist of or include a rupture disk, conduct instrument monitoring, as detected by Method 21 of 40 CFR part 60, appendix A, no later than 5 calendar days after the pressure release to verify that the pressure relief device is operating with an instrument reading of less than 500 ppm above background, except as provided in 40CFR§63.171.
 - 2. If the pressure relief device consists of or includes a rupture disk, install a replacement disk as soon as practicable after a pressure release, but no later than 5 calendar days after the pressure release, except as provided in 40CFR§63.171.
 - c. Pressure release management. Pressure releases to the atmosphere from pressure relief devices in organic HAP service are prohibited.
 - d. Effective March 27, 2017, the permittee must comply with the following requirements for all pressure relief devices in organic HAP service:
 - 1. For each pressure relief device in organic HAP service, the owner or operator must equip each pressure relief device with a device(s) or use a monitoring system that is capable of:
 - i. Identifying the pressure release;
 - ii. Recording the time and duration of each pressure release; and
 - iii. Notifying operators immediately that a pressure release is occurring. The device or monitoring system may be either specific to the pressure relief itself or may be associated with the process system or piping, sufficient to indicate a pressure release to the atmosphere. Examples of these types of devices and systems include, but are not limited to, a rupture disk indicator, magnetic sensor, motion detector on the pressure relief valve stem, flow monitor, or pressure monitor.

2. If any pressure relief device in organic HAP service releases to atmosphere as a result of a pressure release event, the owner or operator must calculate the quantity of organic HAP released during each pressure release event and report this quantity as required in 40CFR§63.1439(e)(6)(ix). Calculations may be based on data from the pressure relief device monitoring alone or in combination with process parameter monitoring data and process knowledge.

[45CSR34 and 40CFR§§63.1434(c)(1), (2), and (3)]

7.2. Monitoring Requirements

- 7.2.1. (i) *ECO monitoring requirements.* The permittee using ECO shall comply with the monitoring requirements of this paragraph to demonstrate continuous compliance with this subpart. Paragraphs (i)(1) through (3) of 40CFR§63.1427 address monitoring of the extended cookout.

(1) To comply with the provisions of 40CFR§63.1427 (process vent provisions), the permittee shall monitor the time from the end of the epoxide feed to the end of ECO

(2) During the determination of the percent epoxide emission reduction in paragraphs (b) through (e) of 40CFR§63.1427, the permittee shall establish, as a level that shall be maintained during periods of operation the following:

(i) The time from the end of the epoxide feed to the end of the ECO;

(3) For each batch cycle where ECO is used to reduce epoxide emissions, the permittee shall record the value of the monitored parameter at the end of the ECO. This parameter is then compared with the level established in accordance with number (2) above, which corresponds with paragraph (i)(2)(i) of 40CFR§63.1427 to determine if an excursion has occurred. An ECO excursion is defined as one of the following:

(i) When the time from the end of the epoxide feed to the end of the ECO is less than the time established in paragraph (i)(2)(i) of 40CFR§63.1427; or

(ii) When the parameter is not measured and recorded at the end of the ECO; or

[45CSR34 and 40CFR§63.1427(i), Emission Unit IDs (R703, R704, R705, R706, R707, R708)]

- 7.2.2. Storage tanks T-9510, 11, 12, and 13 shall comply with the monitoring and reporting provisions of 40CFR60, Subpart Kb for tanks by keeping records of the material stored and associated vapor pressures.

[45CSR16, 40CFR§60.116b(b), Emission Unit ID (T-9510, T-9511, T-9512, T-9513)]

7.3. Testing Requirements

- 7.3.1. N/A

7.4. Recordkeeping Requirements

- 7.4.1. (j) *Recordkeeping requirements.*

(1) The permittee shall maintain the records specified in paragraphs (j)(1)(i) and (ii) of 40CFR§63.1427, for each product class. The permittee shall also maintain the records related to the initial determination of the percent epoxide emission reduction specified in paragraphs (j)(1)(iii) through (ix) of §63.1427, as applicable, for each product class.

- (i) Operating conditions of the product class, including:
- (A) Pressure decay curve;
 - (B) Minimum reaction temperature;
 - (C) Number of reactive hydrogens in the raw material;
 - (D) Minimum catalyst concentration;
 - (E) Ratio of EO/PO at the end of the epoxide feed; and
 - (F) Reaction conditions, including the size of the reactor or batch.
- (ii) A listing of all products in the product class, along with the information specified in paragraphs (j)(1)(i)(A) through (F) of 40CFR§63.1427, for each product, incorporated herein as 7.4.1.(j)(1)(i)(A)-(F) .
- (iii) The concentration of epoxide at the end of the epoxide feed, determined in accordance with paragraph (b)(1) of 40CFR§63.1427, incorporated herein as 7.1.8.
- (iv) The concentration of epoxide at the onset of the ECO, determined in accordance with paragraph (c) of 40CFR§63.1427, incorporated herein as 7.1.9.
- (v) The uncontrolled epoxide emissions at the onset of the ECO, determined in accordance with paragraph (c)(1) of 40CFR§63.1427, incorporated herein as 7.1.9. The records shall also include all the background data, measurements, and assumptions used to calculate the uncontrolled epoxide emissions.
- (vi) The epoxide emissions at the end of the ECO, determined in accordance with paragraph (d)(1) of 40CFR§63.1427, incorporated herein as 7.1.10. The records shall also include all the background data, measurements, and assumptions used to calculate the epoxide emissions.
- (vii) The percent epoxide reduction for the batch cycle, determined in accordance with paragraph (e)(1) of 40CFR§63.1427, incorporated herein as 7.1.11. The records shall also include all the background data, measurements, and assumptions used to calculate the percent reduction.
- (viii) The parameter level, established in accordance with paragraph (i)(3) of 40CFR§63.1427, incorporated herein as 7.2.1.
- (ix) If epoxide emissions occur before the end of the ECO, the permittee shall maintain records of the time and duration of all such emission episodes that occur during the initial demonstration of batch cycle efficiency.
- (2) The permittee shall maintain the following records as applicable from paragraphs (j)(2)(i) through (iv) of 40CFR§63.1427.
- (i) For each batch cycle, the product being produced and the product class to which it belongs.
 - (ii) For each batch cycle, the permittee shall record the time from the end of epoxide feed to the end of extended cook-out.
 - (iii) If epoxide emissions occur before the end of the ECO, the permittee shall maintain records of the time and duration of all such emission episodes.
- [45CSR34 and 40CFR§63.1427(j), Emission Unit IDs (R703, R704, R705, R706, R707, R708)]**

- 7.4.2. For pressure relief devices in organic HAP service subject condition 7.1.17 keep records of each pressure release to the atmosphere, including the following information:
- a. The source, nature, and cause of the pressure release.
 - b. The date, time, and duration of the pressure release.
 - c. The quantity of total HAP emitted during the pressure release and the calculations used for determining this quantity.
 - d. The actions taken to prevent this pressure release.
 - e. The measures adopted to prevent future such pressure releases.

[45CSR34 and 40CFR§63.1439(d)(10)(v)]

7.5. Reporting Requirements

- 7.5.1. The permittee shall submit a semi-annual report containing the following information:
(k) *Reporting requirements.* The permittee shall comply with the reporting requirements in this paragraph.
- (3) The following information shall be provided in the semi-annual Periodic Report, as specified in 40CFR§63.1439(e)(6).
 - (i) Reports of each batch cycle for which an ECO excursion occurred, as defined in 40CFR§63.1427(i)(3)
 - (ii) Notification of each batch cycle when the time and duration of epoxide emissions before the end of the ECO, recorded in accordance with paragraph (j)(2)(v) of 40CFR§63.1427 (Condition 7.4.2.(ii) of this permit), exceed the time and duration of the emission episodes during the initial epoxide emission percentage reduction determination, as recorded in paragraph (j)(1)(viii) of 40CFR§63.1427 (Condition 7.4.1.(viii) of this permit)
- [45CSR34 and 40CFR§63.1427(k)(3)(i)&(ii), 40CFR§63.1439(e)(6), Emission Unit IDs (R703, R704, R705, R706, R707, R708)]**
- 7.5.2. The permittee shall comply with the reporting requirements for new polyether poly products as provided by 40CFR§63.1427(l).
[45CSR34 and 40CFR§63.1427(l)., Emission Unit ID (R703, R704, R705, R706, R707, R708)]
- 7.5.3. The permittee shall comply with the reporting requirements for polyether polyol product changes as provided by 40CFR§63.1427(m).
[45CSR34 and 40CFR§63.1427(m)., Emission Unit ID (R703, R704, R705, R706, R707, R708)]
- 7.5.4. The permittee shall comply with the reporting requirements for polyether polyol product manufacturing units as provided by 40CFR§63.1439(e)(6)(i) through (viii) of this section
[45CSR34 and 40 CFR§63.1439(e)(6)., Emission Unit ID (R703, R704, R705, R706, R707, R708)]
- 7.5.5. The permittee shall comply with the reporting requirements for equipment leak provisions as provided by 40CFR§63.1434(f).
[45CSR34 and 40 C.F.R. §63.1439(e)(6)(vii)., Emission Unit IDs (R703, R704, R705, R706, R707, R708)]

7.5.6. For existing and new affected sources covered by 40CFR63, Subpart PPP, a Notification of Compliance Status shall be submitted no later than August 24, 2017. For equipment leaks subject to 40CFR§63.1434, the permittee shall submit the information specified in the HON equipment leak Notification of Compliance Status requirements in 40CFR§63.182(c), in the Notification of Compliance Status required by this condition. For pressure relief devices subject to the requirements condition 7.1.17, the permittee shall submit the information required in Condition 7.5.7 in the Notification of Compliance Status no later than August 24, 2017.
[45CSR34 and 40CFR§63.1439(e)(5)]

7.5.7. For pressure relief devices in organic HAP service covered by 40 CFR 63, Subpart PPP, a description of the device or monitoring system to be implemented, including the pressure relief devices and process parameters to be monitored (if applicable), a description of the alarms or other methods by which operators will be notified of a pressure release, and a description of how the owner or operator will determine the information to be recorded under condition 7.4.2 (i.e., the duration of the pressure release and the methodology and calculations for determining of the quantity of total HAP emitted during the pressure release).
[45CSR34 and 40CFR§63.1439(e)(5)(viii)]

7.6. Compliance Plan

7.6.1. Not Applicable

8.0 Source-Specific Requirements [Toxic Air Pollutant Sources, Incorporation of 45CSR27 Standards and Consent Order #CO-R27-2024-03, Emission Point ID(s)(Listed Below 8.1.5 Tables)]

8.1. Limitations and Standards

- 8.1.1. Except as provided in Sections 3.2 and 3.3 of 45CSR27, the owner or operator of a plant that discharges or may discharge a toxic air pollutant into the open air in excess of the amount shown in Table A of 45CSR27 shall employ BAT at all chemical processing units emitting the toxic air pollutant: Provided, that any source or equipment specifically subject to a federal regulation or standard shall not be required to comply with provisions more stringent than such regulation or standard.
[45CSR§27-3.1., State-Enforceable Only]
- 8.1.2. All chemical processing units shall be properly instrumented to alert the operator of process upsets, leaks, and other abnormal discharges of toxic air pollutants into the air and the operator shall record all such incidents and the associated emissions estimated from direct measurements of toxic air pollutant concentration and/or calculations using other process measurements.
[45CSR§27-3.4., State-Enforceable Only, Process Unit IDs (N. Chas. Distribution, Chemical Mixing, Specialty Surfactants, Oxide Adducts)]
- 8.1.3. Owners and operators of chemical processing units and/or wastewater treatment systems subject to 45CSR27 shall employ BAT to remove and control or destroy toxic air pollutants from wastewater at the source and/or apply BAT at the wastewater treatment plant to prevent or control the discharge to toxic air pollutants resulting from air stripping or evaporation: Provided, that this provision shall not be more stringent than any specifically applicable federal regulation or standard.
[45CSR§27-6.1., State-Enforceable Only]
- 8.1.4. Owners and operators of chemical processing units or facilities subject to the requirements of 45CSR27 shall employ BAT to prevent or control toxic air pollutant discharges in the loading and unloading of railcars and tank trucks with toxic air pollutants or material mixtures containing toxic air pollutants.
[45CSR§27-7.1., State-Enforceable Only]
- 8.1.5. The permittee shall implement “BAT” in accordance with the compliance plan agreed upon within consent order number, CO-R27-2024-03, for the control of ethylene oxide and propylene oxide emissions. As a result, the following emission limits and BAT Controls shall apply:

a. Propylene Oxide Requirements

Table 8.1.5.a. Propylene Oxide Emissions

Source ID	Control Description	Emission Point ID	Pre-Control Emissions	Allowable Emissions
			(lb/yr)	(lb/yr)
#1 Drop Tank	Extended Cookout	E-703A	9,400	198
#2 Drop Tank	Extended Cookout	E-704A	6,800	189
#4 Drop Tank	Extended Cookout	E-705A	1,100	1023
#5 Drop Tank	Extended Cookout	E-706A	6,800	189
#6 Drop Tank	Extended Cookout	E-708A	1,700	289
#7 Drop Tank	Extended Cookout	E-707A	2,500	600
Subtotal			28,300	2,488 ¹

Source ID	Control Description	Emission Point ID	Pre-Control Emissions	Allowable Emissions
Oxide Adducts			(lb/yr)	(lb/yr)
#1 Treatment	Extended Cookout	E-703B	20,000	407
#2 Treatment	Extended Cookout	E-704B	17,600	478
#4 Treatment	Extended Cookout	E-705B	800	954
#5 Treatment	Extended Cookout	E-706B	17,600	478
#6 Treatment	Extended Cookout	E-708B	400	470
#7 Treatment	Extended Cookout	E-707B	900	217
		Subtotal	57,300	3,004 ¹
#1 Vacuum Jet	None	E-703C	71.5	71.5
		Total	85,672	5,564
#1 Double Valve and Vent	Double Valve and Buffer	E-720	98	0
#2 Double Valve and Vent	Double Valve and Buffer	E-721	43	0
#4 Double Valve and Vent	Double Valve and Buffer	E-722	52	0
#5 Double Valve and Vent	Double Valve and Buffer	E-723	28	0
#6 Double Valve and Vent	Double Valve and Buffer	E-724	20	0
#7 Double Valve and Vent	Double Valve and Buffer	E-725	13	0
Wastewater Secondary Emissions	Eliminated by installation of double valve and buffer stations	700	134 ²	0 ²
		Total	388	0
Treatment represents the handling of material after it leaves the drop tanks, it does not refer to a single source				

¹ Individual reactor emissions may vary with product mix. The total from all reactor systems represents the maximum annual emissions limitation for the six reactor systems.

² Fugitive emissions controlled by work practices and estimated empirically. The fugitive emission numbers are provided for informational purposes only.

[CO-R27-2024-03, Order for Compliance 11 and 12, State-Enforceable Only]

b. Ethylene Oxide Requirements

Table 8.1.5.b. Ethylene Oxide Emissions

Source ID	Control Description	Emission Point ID	Pre-Control Emissions	Allowable Emissions
Oxide Adducts			(lb/yr)	(lb/yr)
#2 Drop Tank	Extended Cookout	E-704A	120	15
#4 Drop Tank	Extended Cookout	E-705A	20	<1
#5 Drop Tank	Extended Cookout	E-706A	120	14
#6 Drop Tank	Extended Cookout	E-708A	10	<1
#7 Drop Tank	Extended Cookout	E-707A	20	<1
		Subtotal	290	30 ¹
#2 Treatment	Extended Cookout	E-704B	320	<1
#4 Treatment	Extended Cookout	E-705B	15	<1
#5 Treatment	Extended Cookout	E-706B	320	<1
#6 Treatment	Extended Cookout	E-708B	5	<1
#7 Treatment	Extended Cookout	E-707B	2	<1
		Subtotal	662	2 ¹
		Total	952	32
#2 Double Valve and Vent	Double Valve and Buffer	E-721	90	0
#4 Double Valve and Vent	Double Valve and Buffer	E-722	35	0
#5 Double Valve and Vent	Double Valve and Buffer	E-723	60	0
#6 Double Valve and Vent	Double Valve and Buffer	E-724	54	0
#7 Double Valve and Vent	Double Valve and Buffer	E-725	38	0
Wastewater Secondary Emissions	Eliminated by installation of double valve and buffer stations	700	30 ²	0 ²
		Total	307	0
Treatment represents the handling of material after it leaves the drop tanks, it does not refer to a single source				

¹ Individual component emissions may vary with product mix. The total from all reactor systems represents the maximum annual emissions limitation for the five reactor systems.

² Fugitive emissions controlled by work practices and estimated empirically. The fugitive emission numbers are provided for informational purposes only.

[CO-R27-2024-03, Order for Compliance 11 and 12, State-Enforceable Only]

c. Fugitive Emission Requirements

All owners and operators subject to the requirements of 45CSR27 shall, by application of BAT, prevent and control fugitive emissions to the air of toxic air pollutants as a result of leakage from equipment in toxic air pollutant service including but not limited to, pump seals, compressor seals, valves, sampling connections, open-ended lines, safety relief valves, and flanges. In no event shall any equipment standard, program, or work practice less stringent than required under 40CFR61, Subpart V be deemed to represent BAT for control of toxic air pollutant emissions: Provided, that any source or equipment specifically subject to a federal regulation or standard shall not be required to comply with provisions more stringent than such federal regulation and standard. Equipment to be used in toxic air pollutant service installed after the effective date of 45CSR27 shall, to the maximum extent possible, be designed and operated so as to prevent leaks of toxic air pollutants.

The facility shall comply with 45CSR§27-4.1 through compliance with the Leak Detection and Repair (LDAR) Requirements of 40CFR63, Subpart H.

[45CSR§27-4.1., CO-R27-2024-03, Findings of Fact 7.a, 7.b, 7.c, State-Enforceable Only]

- 8.1.6. Reserved.
- 8.1.7. The Facility shall not have facility-wide emissions (including point source and fugitives) of Ethylene Oxide in excess of five hundred (500) pounds per calendar year. The Facility shall not have facility-wide emissions (including point source and fugitives) of formaldehyde in excess of one thousand (1,000) pounds per calendar year for chemical processing units, without the application of BAT.

[CO-R27-2024-03, Order for Compliance 12]

8.2. Monitoring Requirements

- 8.2.1. To demonstrate compliance with Condition 8.1.5.c. of this permit, written records shall be maintained that identify all pumps, compressors, pressure relief valves, valves, sampling connections, open-ended lines, and flanges of a chemical processing unit that are in toxic air pollutant service. These records shall record the results of all monitoring and inspections, emissions control measures applied and the nature, timing, and results of repair efforts in accordance with 40CFR63, Subpart H.

[45CSR§27-10.3., State-Enforceable Only, 45CSR§30-12.7]

- 8.2.2. Except as provided below, compliance with the requirements of Condition 8.1.5 for the Oxide Adducts Manufacturing Plant shall be demonstrated by adhering to the monitoring, recordkeeping, and reporting provisions in accordance with Section 7.0 of this permit.

(i). Ethylene oxide (EO) and propylene oxide (PO) emissions from the double valve and vent system shall continue to be eliminated through the use of a work practice defined as the double valve and buffer system, which utilizes nitrogen pressure placed between the valves sufficient enough to then push any remaining EO or PO into the process.

[45CSR27, 45CSR34, 40CFR63, Subpart PPP]

- 8.2.3. Reserved.

- 8.2.4. Reserved.

8.2.5. To demonstrate compliance with 45CSR27 “BAT” requirements for emissions of toxic air pollutants from the Specialty Surfactants Plant, the permittee shall adhere to the limitations, monitoring, recordkeeping, and reporting provisions in accordance with Section 5.0 of this permit.

[45CSR13, Permit Number R13-1517, State-Enforceable Only]

8.2.6. Reserved.

8.2.7. Reserved.

8.2.8. To demonstrate compliance with the Regulation 27 Consent Order provisions for wastewater, the permittee shall comply with the process wastewater provisions of applicable standards from 40 CFR 63, Subparts G and PPP or 40 CFR 63, Subpart FFFF, as applicable under Section 63.2485.

[CO-R27-2024-03, State-Enforceable Only]

8.3. Testing Requirements

8.3.1. At such reasonable times as the Director may designate, the owner or operator of any chemical processing unit may be required to conduct or have conducted tests to determine the compliance with 45CSR27. Such tests shall be conducted in such manner as the Director may specify or approve and be filed on forms and in a manner specified by the Director. The Director, or his duly authorized representative, may at his option witness or conduct such tests. Should the Director exercise his option to conduct such tests, the operator will provide all the necessary sampling connections and sampling ports to be located in such manner as the Director may require, power for test equipment, and the required safety equipment such as scaffolding, railing, and ladders to comply with generally accepted good safety practices.

[45CSR§27-10.1., State-Enforceable Only]

8.4. Recordkeeping Requirements

8.4.1. The Facility shall keep records of calculations used to show compliance with emissions limits referenced in section 8.1.5.a, 8.1.5.b, and 8.1.7. All records referenced in CO-R27-2024-03 shall be maintained onsite for a period of five (5) years and be made available to DAQ personnel upon request.

[CO-R27-2024-03, Order for Compliance 13 and 15, State-Enforceable Only]

8.5. Reporting Requirements

8.5.1. Reserved.

8.5.2. The emission to the air of any toxic air pollutant resulting from an abnormal release or spill in excess of the following amounts shall be reported to the Director or his authorized representative not later than 24-hours after the chemical processing unit owner/operator has knowledge of such emission:

10.4.a. For ethylene oxide, and vinyl chloride, one (1) pound

10.4.b. For acrylonitrile and butadiene, ten (10) pounds

10.4.c. For all other toxic air pollutants, fifty (50) pounds.

The permittee shall file a written report with the Director stating the details of all such incidents resulting in the emission of more than fifty (50) pounds of any toxic air pollutant within seven (7) days of the occurrence. The

owner/operator shall submit to the Director, at his request, records of all abnormal toxic air pollutant discharges to the air.

[45CSR§27-10.4., State-Enforceable Only]

- 8.5.3. Any period of failure or inoperability of air pollution control equipment required by 45CSR27 shall be reported to the Director not later than 24-hours after the owner/operator has knowledge of such failure. Such reports shall be made in conjunction with necessary requests for variances as provided under 45CSR§27-12.

[45CSR§27-10.5., State-Enforceable Only]

8.6. Compliance Plan

N/A

9.0 Source-Specific Requirements [Volatile Organic Compound Sources and Incorporation of 45CSR21 Standards and Consent Order # CO-R21-98-22, ID(s)(Listed in Attachment B)]

9.1. Limitations and Standards

The permittee shall implement an Alternate Emissions Reduction Plan (AERP) in accordance with the compliance plan agreed upon within consent order number, CO-R21-98-22, and any amendments thereof for the control of VOCs. As a result, the following emission limits and LDAR program shall apply:

- 9.1.1. The permittee shall, on and after June 6, 1998, reduce VOC emissions from the sources listed in Attachment A of CO-R21-98-22 as amended by UCC letter dated October 10, 2006 from J. L. Blatt, UCC Responsible Care Leader to John A Benedict, Director of WVDAQ, and incorporated herein as Attachment B; and shall continue to comply with such emissions reduction requirements and the emission limits set forth in Attachment A of CO-R21-98-22, as revised, as expressly provided by the referenced consent order. Compliance with the emission limits set forth in CO-R21-98-22, as revised, and included herein as Attachment B shall be demonstrated by test or monitoring data, approved emission factors, material balances, and/or representative calculations in accordance with 45CSR21.

[CO-R21-98-22, III.1. State-Enforceable Only]

- 9.1.2. Unless otherwise expressly exempted from Leak Detection and Repair (“LDAR”) requirements in CO-R21-98-22, the COMPANY hereby agrees to implement and maintain LDAR programs for the reduction of fugitive VOC emissions in all FACILITY manufacturing process units subject to 45CSR21 Section 40 producing a product or intermediate or final, in excess of 1000 mega grams (1100 tons) per year in accordance with the applicable methods and criteria of 45CSR21 Section 37 or alternative procedures approved by the DIRECTOR. This requirement shall apply to all units irrespective of whether or not such units produce as intermediates or final products, substances on the list contained within 40CFR60, 40CFR61, or 40CFR63. The permittee will follow the applicable requirements of 45CSR§21-37 for LDAR requirements for all equipment except for the North Charleston Distribution Terminal, the Chemical Mixing Area, and the fugitive emission components associated with the equipment listed below:

Process Unit	Process ID	Equipment for which LDAR monitoring is not required
Specialty Surfactants	1000	Raw material tanks 8332, 8354, 8333, 8353, 8363, Intermediate tanks 8323, 8343, 8344, 8324, 8382 Neat products tanks 8373, aqueous product tanks 8364 and 8383, and the X-200 process system including the 8700 reactor and tank 8381
Oxide Adducts	700	Product tanks and Drop tanks 9614, 9616, 9617, 9624, and 9627

In addition, those components in Specialty Surfactants Process area 1000 that are in light liquid service less than 300 hours per year will be subject only to the heavy liquid LDAR.

Although the above listed units are exempted from the frequency of testing as described in 45CSR§21-37, LDAR testing of these units will be required every three years, upon request by the Director or his or her duly authorized representative. Waiver or rescheduling of LDAR testing every three years may be granted by the Director if a written request and justification are submitted by the permittee. Units exempted from LDAR monitoring as required by 45CSR§21-37, are not exempted from testing which may be required under any other applicable State or Federal regulations, orders or permits.

The Director may periodically require verification by the Permittee that maintenance and repair procedures associated with approved exemptions are continued and practiced.

[CO-R21-98-22, III.2. State-Enforceable Only]

- 9.1.3. At all times, including periods of start-up, shutdown, and malfunction, the permittee shall maintain and operate the VOC emitting sources and associated air pollution control devices subject to the provisions of CO-R21-98-22 in a manner consistent with good air pollution control practices for minimizing emissions. Compliance with the emission limits set forth in Attachment B of this Title V Permit shall be demonstrated at all times unless exception periods are provided for in accordance with this paragraph. The permittee shall comply with 45CSR§21-5.2 and 45CSR§21-9.3 with respect to all periods of non-compliance with the emission limitations and emission reduction request set forth in Attachment B resulting from unavoidable malfunctions of equipment. In the event that the emission limitation and/or emission reduction requirements for a source listed in Attachment B cannot be met during route start-up, shutdowns, or routine maintenance activities, the permittee shall, within 180 days of June 6, 1998, submit an operation and VOC emissions mitigation plan for such periods. This plan is included within the Title V Permit as Attachment C. The Director may require reasonable revisions to the permittee's plan if he or she finds that routine start-up, shutdown, or maintenance resulting in excess VOC emissions not addressed by the plan occur or that the plan fails to provide for operation in a manner consistent with good air pollution control practices for minimizing emissions. VOC emissions and associated control procedures conforming to the permittee's plan submitted under this provision shall not be subject to the variance approval process of 45CSR§21-9.3 provided that the permittee maintains test, monitoring, operating, and maintenance records containing sufficient information and detail to enable the permittee and the Director to verify compliance with the plan and associated VOC emission control requirements. These records shall be maintained on-site for not less than three (3) years and be made available to the Director or his or her authorized representative upon request.

[CO-R21-98-22, III.3. State-Enforceable Only]

- 9.1.4. The permittee agrees that construction or modification of any emission source having maximum theoretical emissions of VOC equaling or exceeding six pounds per hour after May 1, 1996 shall require the prior approval by the Director of an emission control plan that meets the definition of Reasonably Available Control Technology (RACT) on a case-by-case basis for both fugitive and non-fugitive VOC emissions from such source. All RACT control plans for sources constructed or modified (as defined herein) after May 1, 1996 shall be embodied in a permit in accordance with 45CSR13 or 45CSR30. Physical changes to or changes in the method of operation of an existing emission source listed or required to be listed in Attachment B which do not result in an increase in its potential to emit VOCs in a cumulative amount of two pounds per hour or five tons per year or more (with cumulative accounting commencing on June 6, 1998) shall not require submittal of a RACT plan, provided that, the permittee continues to comply with its facility wide VOC emission reduction requirement (RACM or AERP). For existing sources or emission units with current maximum theoretical emissions below the threshold of six pounds per hour, the permittee shall not be required to submit a RACT plan for that particular source, if a modification causes an increase in the maximum emissions that results in the source exceeding the six pounds per hour level for the first time, as long as the increase is less than the two pounds per hour or five tons per year.

[CO-R21-98-22, III.7. State-Enforceable Only]

- 9.1.5. Reports of excess emissions. -- Except as provided in 45CSR§21-9.3., the owner or operator of any facility containing sources subject to 45CSR§21-5. shall, for each occurrence of excess emissions expected to last more than 7 days, within 1 business day of becoming aware of such occurrence, supply the Director by letter with the following information:

- a. The name and location of the facility;

- b. The subject sources that caused the excess emissions;
- c. The time and date of first observation of the excess emissions; and
- d. The cause and expected duration of the excess emissions.
- e. For sources subject to numerical emission limitations, the estimated rate of emissions (expressed in the units of the applicable emission limitation) and the operating data and calculations used in determining the magnitude of the excess emissions; and
- f. The proposed corrective actions and schedule to correct the conditions causing the excess emissions.

[45CSR§21-5.2]

- 9.1.6. Variance. -- If the provisions of this regulation cannot be satisfied due to repairs made as the result of routine maintenance or in response to the unavoidable malfunction of equipment, the Director may permit the owner or operator of a source subject to this regulation to continue to operate said source for periods not to exceed 10 days upon specific application to the Director. Such application shall be made prior to the making of repairs and, in the case of equipment malfunction, within 24 hours of the equipment malfunction. Where repairs will take in excess of 10 days to complete, additional time periods may be granted by the Director. In cases of major equipment failure, additional time periods may be granted by the Director provided a corrective program has been submitted by the permittee and approved by the Director. During such time periods, the permittee shall take all reasonable and practicable steps to minimize VOC emissions.

[45CSR§21-9.3]

- 9.1.7. In the event that the DAQ finds that a violation of the National Ambient Air Quality Standards (NAAQS) for ozone (that were in effect on or before May 1, 1996) has occurred after the effective date of Consent Order CO-R21-98-22, the permittee agrees to submit to the DAQ a plan within one hundred eighty (180) days of notification of such a finding for complete, FACILITY-wide implementation of RACT requirements and shall fully implement such plan within two (2) years of its approval by the DAQ.

[CO-R21-98-22, III.9. State-Enforceable Only.]

- 9.1.8. Unless granted a variance pursuant to 45CSR§21-9.3, the permittee shall operate all emission control equipment for those emission sources listed in Attachment B, at all times when the production unit is in operation or when any VOC emitting activity is occurring. In the event that the control equipment is inoperable, the production unit shall be shut down or the activity shall be discontinued as expeditiously as possible.

[CO-R21-98-22, IV.7. State-Enforceable Only.]

- 9.1.9 The permittee shall operate all solvent metal cleaners in accordance with the provisions of 45CSR§§21-30.3.a.4 through 30.3.a.9 as follows:

- 1. Provide a permanent, legible, conspicuous label, summarizing the operating requirements;
- 2. Store waste solvent in covered containers;
- 3. Close the cover whenever parts are not being handled in the cleaner;
- 4. Drain the cleaned parts until dripping ceases;

5. If used, supply a solvent spray that is a solid fluid stream (not a fine, atomized, or shower-type spray) at a pressure that does not exceed 10 pounds per square inch gauge (psig); and
6. Degrease only materials that are neither porous nor absorbent.

[State Enforceable Only; 45CSR§21-30.3.a.4 through §30.3.a.9, Equipment ID (Building 307 Shop)]

- 9.1.10 State Rule 45CSR21, stage I vapor recovery requirements apply to the permittee's underground gasoline storage tank as follows:

45CSR§21-23.1.c. Any gasoline dispensing facility with a throughput of less than 38,000 L (10,000 gal) per month is subject only to the provisions of sections 45CSR§21-23.2.a.1. and 45CSR§21-23.3.

45CSR§21-23.2. Standards.

45CSR§21-23.2.a. The owner or operator of each gasoline dispensing facility subject to this section 23 shall comply with the following requirements:

1. All gasoline storage vessels at gasoline dispensing facilities shall be loaded by submerged fill;
[45CSR§21-23.2.a.1., Equipment ID (T-1490)]

9.2. Monitoring, Testing, Recordkeeping, and Reporting Requirements

- 9.2.1. The monitoring requirements specified within section 5.0 for Specialty Surfactants and 7.0 for Oxide Adducts of this permit shall also demonstrate compliance with the requirements of section 9.1 above.

[45CSR13, Permit Number R13-1517, 40CFR63, Subpart PPP, Subpart H,F,G]

- 9.2.2. In accordance with 45CSR21 the permittee shall keep the following records pertaining to its underground gasoline tank.:

45CSR§21-23.3. Recordkeeping. -- The owner or operator of each gasoline dispensing facility subject to this section 23 shall maintain daily records showing the quantity of all gasoline delivered to the site. These records shall be retained for at least 3 years in a readily accessible location and shall be made available to the Director upon verbal or written request.

[45CSR§21-23.3., Emission Unit ID (T-1490)]

9.3. Compliance Plan

- 9.3.1. N/A

10.0. Source-Specific Requirement [Groundwater/Soil Remediation-- Chlorohydrin/Chlorobenzene (SVE1, SVE2, and SVE3), Middle Island Source 2 (MI2VE2), and MIGCS (MIGCS1 and MIGCS2) Under 40 C.F.R. 63, Subpart GGGGG]

10.1 Limitations and Standards

- 10.1.1 For each site remediation with an affected source designated under §63.7882 (*process vents, remediation units, and equipment leaks*), you must meet the standards specified in §§63.7885 (10.1.2) through 63.7955, as applicable to your affected source, unless your site remediation meets the requirements for an exemption under the following paragraph.

A site remediation that is completed within 30 consecutive calendar days according to the conditions in paragraphs §63.7884(b)(1) through (3) is not subject to the standards in the paragraph above.
[45CSR34, 40 C.F.R. §63.7884]

- 10.1.2. For the process vents that comprise the affected source designated under 40 CFR §63.7882(a)(1), you must control HAP emissions from the affected process vents according to the standards specified in 40 CFR §63.7890 (*facility wide limit for total organic compounds*), §63.7891 (*design evaluation and closed vent system*), §63.7892 (*inspection and monitoring for process vents*), and §63.7893 (*emission limits and work practice standards for process vents*); or determine the average total volatile organic hazardous air pollutant (VOHAP) concentration, as defined in 40CFR§63.7957 is less than 10 parts per million by weight (ppmw). Determination of the VOHAP concentration is made using the procedures specified in §63.7943.
[45 CSR 34, 40CFR§§63.7885(a), (b), (b)(1), and (b)(2).]

- 10.1.3. For each remediation material management unit that is part of an affected source designated by 40CFR §63.7882, you must select and meet the requirements under one of the options specified in §63.7886(b).

You determine that the average total VOHAP concentration, as defined in 40CFR§63.7957, of the remediation material managed in the remediation material management unit material is less than 500 ppmw. You must follow the requirements in 40CFR§63.7943 to demonstrate that the VOHAP concentration of the remediation material is less than 500 ppmw. Once the VOHAP concentration for a remediation material has been determined to be less than 500 ppmw, all remediation material management units downstream from the point of determination managing this material meet the requirements of this paragraph unless a remediation process is used that concentrates all, or part of, the remediation material being managed in the unit such that the VOHAP concentration of the material could increase. Any free product returned to the manufacturing process is no longer subject to this subpart.
[45 CSR 34, 40CFR§§63.7886(a) and (b)(2)]

- 10.1.4. For your affected process vents, you must reduce the emissions of total organic compounds (TOC) (minus methane and ethane) to a level below 1.4 kg/hr and 2.8 Mg/yr (3.0 lb/hr and 3.1 tpy) from all affected process vents. If you have multiple affected process vent streams, you may comply using a combination of controlled and uncontrolled process vent streams that achieve this facility-wide emission limit.
[45 CSR 34, 40CFR§§63.7890(a), (b) and (b)(2)]

- 10.1.5. For each closed vent system and control device you use to comply with 10.1.4., you must meet the operating limit requirements and work practice standards in 40CFR§63.7925(c) through (j) that apply to your closed vent system and control device.
[45 CSR 34, 40CFR§63.7890(c)]

- 10.1.6. You must demonstrate initial compliance with the emissions limitations and work practice standards in 10.1.4. applicable to your affected process vents by meeting the requirements in 10.1.6.1 through 10.1.6.3.
- 10.1.6.1. You have measured or determined using the procedures for performance tests and design evaluations in 40CFR§63.7941 that emission levels from all of your affected process vents meet the facility-wide emission limits in 10.1.4. by demonstrating that emissions of TOC (minus methane and ethane) from all affected process vents at your facility are less than 1.4 kg/hr and 2.8 Mg/yr (3.0 lb/hr and 3.1 tpy).
- 10.1.6.2. For each closed vent system and control device you use to comply with 10.1.4., you have met each requirement for demonstrating initial compliance with the emission limitations and work practice standards for a closed vent system and control device in 10.1.9.
- 10.1.6.3. You have submitted a notification of compliance status according to the requirements in 40CFR§63.7950.
[45 CSR 34, 40CFR§§63.7891(a), (b), (b)(2), (c) and (d)]
- 10.1.7. You must demonstrate continuous compliance with the emission limitations and work practice standard in 10.1.4. applicable to your affected process vents by meeting the requirements 10.1.7.1. through 10.1.7.3. of this section.
- 10.1.7.1. You must maintain emission levels from all of your affected process vents to meet the facility-wide emission limits in 10.1.4.
- 10.1.7.2. For each closed vent system and control device you use to comply with 10.1.4., you have met each requirement for demonstrating continuous compliance with the emission limitations and work practice standards for a closed vent system and control device in 40CFR§63.7928 (see conditions 10.1.10-13).
- 10.1.7.3. Keeping records to document continuous compliance with the requirements of 40CFR63, Subpart GGGGG according to the requirements in 40CFR§63.7952 (see conditions 10.4.1 – 4).
[45 CSR 34, 40CFR§§63.7893(a), (b), (b)(2), (c), and (d)]
- 10.1.8. For each closed-vent system and control device you use to comply with requirements in 40CFR§63.7890 through §63.7922, as applicable to your affected sources, you must meet the following emissions limitations and work practice standards:
- 10.1.8.1. Whenever gases or vapors containing HAP are vented through the closed-vent system to the control device, the control device must be operating, except that the control device on a tank may be bypassed for the purpose of performing planned routine maintenance of the control device. When the tank control device is bypassed, the owner or operator must comply with paragraphs 10.1.8.1 a. through c. of this section.
- a. The control device may only be bypassed when the planned routine maintenance cannot be performed during periods that tank emissions are vented to the control device.
 - b. On an annual basis, the total time that the closed-vent system or control device is bypassed to perform routine maintenance must not exceed 240 hours per each calendar year.
 - c. The level of material in the tank must not be increased during periods that the closed-vent system or control device is bypassed to perform planned routine maintenance.

- 10.1.8.2. For each closed vent system, you must meet the following work practice standard in 40CFR§63.693(c).
- a. A closed-vent system that is designed to operate at a pressure below atmospheric pressure shall be equipped with at least one pressure gauge or other pressure measurement device that can be read from a readily accessible location to verify that negative pressure is being maintained in the closed-vent system when the control device is operating.
- 10.1.8.3. For each control device other than a flare or a control device used to comply with the facility-wide process vent emission limit in 10.1.4 you must control HAP emissions to meet either of the emission limits in paragraph 10.1.8.3.a. or b.
- a. Reduce emissions of total HAP listed in Table 1 of 40CFR63, Subpart GGGGG or TOC (minus methane and ethane) from each control device by 95 percent weight; or
 - b. Limit the concentration of total HAP listed in Table 1 of 40CFR63, Subpart GGGGG or TOC (minus methane and ethane) from each combustion control device (a thermal incinerator, catalytic incinerator, boiler, or process heater) to 20 ppmv or less on a dry basis corrected to 3 percent oxygen.
- 10.1.8.4. For control device CLB2VGAC, you must maintain the hourly average temperature of the adsorption bed less than or equal to the temperature established during the design evaluation or performance test.
- 10.1.8.5. For control devices MI2CO and CATOX, you must meet the following operating limits.
- a. You must maintain the daily average temperature of the catalyst bed greater than or equal to the minimum temperature established during the performance test or design evaluation.
 - b. You must replace the existing catalyst bed with a bed that meets the replacement specifications before the age of the bed exceeds the maximum allowable age established in the design evaluation or during the performance test.
- 10.1.8.6. For control device A42INC, you must meet the following operating limit.
- a. You must maintain the daily average firebox temperature greater than or equal to the temperature established in the design evaluation or during the performance test.
[45 CSR 34, 40CFR§§63.7925(a), (b)(2), (c), (d)(1-2), (g)(2, 4-5), and, 40CFR§63.693(c)(1)(ii)]
- 10.1.9. You must demonstrate initial compliance with the emission limitations and work practice standards of 40CFR 63, Subpart GGGGG applicable to your closed vent system and control device by meeting the requirements of 40CFR§63.7926(b)-(h) that apply to your closed vent system and control device.
[45 CSR 34, 40CFR§63.7926(a)]
- 10.1.10. You must demonstrate continuous compliance with the emission limitations and work practice standards of 40 CFR63, Subpart GGGGG applicable to your closed vent system and control device by meeting the following requirements.

- 10.1.10.1. For a closed vent system designed to operate below atmospheric pressure, visually inspecting the closed vent system at least annually according to the requirements in 40CFR§63.695(c)(2)(ii).
- 10.1.10.2. Repairing defects according to the requirements in 40CFR§63.695(c)(3).
- 10.1.10.3. Keeping records of each inspection that include the following information:
 - a. A closed vent system identification number (or other unique identification description you select.)
 - b. Date of each inspection.
 - c. If a defect is detected during an inspection, the location of the defect, a description of the defect, the date of detection, the corrective action taken to repair the defect, and if repair is delayed, the reason for any delay and the date completion of the repair is expected.
- 10.1.10.4. If you elect to monitor the closed vent system according to the requirements of 40CFR§63.172(f) through (j), recording the information in 40CFR§63.181.

[45 CSR 34, 40CFR§§63.7928(a) and (b)(2, 3, 4, 5)]

- 10.1.11. You must demonstrate continuous compliance of each control device subject to the emissions limits in 10.1.8.3 with the applicable emission limit in 10.1.8.3 by meeting 10.1.11.1 or 10.1.11.2 of this section.

- 10.1.11.1. For the emission limit in 10.1.8.3.a, maintaining the reduction in emissions of total HAP listed in Table 1 of 40CFR63, Subpart GGGGG or TOC (minus methane and ethane) from the control device at 95 percent by weight or greater.

- 10.1.11.2. For the emission limit in 10.1.8.3.b, maintaining the concentration of total HAP listed in Table 1 of 40CFR63, Subpart GGGGG or TOC (minus methane and ethane) from the control device at 20 ppmv or less.

[45 CSR 34, 40CFR§63.7928(c)]

- 10.1.12. You must demonstrate continuous compliance of each control device subject to operating limits in 10.1.8.5 and 10.1.8.6 with the applicable limit by meeting the following requirements.

- 10.1.12.1. Maintaining each operating limit according to the requirements in 10.1.8.5 and 10.1.8.6 as applicable to the control device.

- 10.1.12.2. Monitoring and inspecting each control device according to the requirements in 10.2.2 and 10.2.3.

- 10.1.12.3. Operating and maintaining each continuous monitoring system according to requirement 40 CFR§63.7945 and collecting and reducing data according to the requirements in 40CFR §63.7946.

- 10.1.12.4. Keeping records to document compliance with the requirements of 40CFR§63.7952.

[45 CSR 34, 40CFR§63.7928(d)]

- 10.1.13. You must demonstrate continuous compliance with the catalyst replacement work practice standards for catalytic incinerators in 10.1.8.5.b by meeting the following requirements.
- 10.1.13.1. Replacing the existing catalyst bed as required in 10.1.8.5.b.
- 10.1.13.2. Keeping records to document compliance with the requirements of the work practice standards.
[45 CSR 34, 40CFR§63.7928(h)]
- 10.1.14. For each closed vent system and control device you use to comply with 10.1.4 (40CFR§63.7890(b)), you must monitor and inspect the closed vent system and control device according to the requirements in section 10.2.
[45 CSR 34, 40CFR§63.7892]
- 10.1.15. You must be in compliance with the emission limitations (including operating limits) and the work practice standards if 40 CFR 63, Subpart GGGGG at all times.
[45 CSR 34, 40CFR§63.7935(a)]
- 10.1.16. At all times, you must operate and maintain any affected source, including associated air pollution control equipment and monitoring equipment, in a manner consistent with safety and good air pollution control practices for minimizing emissions. The general duty to minimize emissions does not require you to make any further efforts to reduce emissions if levels required by the applicable standard have been achieved. Determination of whether a source is operating in compliance with operation and maintenance requirements will be based on information available to the Administrator which may include, but is not limited to, monitoring results, review of operation and maintenance procedures, review of operation and maintenance records, and inspection of the source.
[45 CSR 34, 40CFR§63.7935(b)]
- 10.1.17. You must report each instance in which you did not meet each emissions limitation and each operating limit that applies to you. You must also report each instance in which you did not meet the requirements for work practice standards that apply to you. These instances are deviations from the emissions limitations and work practice standards in 40 CFR 63, Subpart GGGGG. These deviations must be reported according to the requirements in 40CFR§63.7951.
[45 CSR 34, 40CFR§63.7935(e)]
- 10.1.18. You must be in compliance with the emission limitations in this subpart at all times (unless a longer timeframe for compliance is expressly provided in this subpart), and we will determine whether deviations that occur during a period of startup, shutdown, or malfunction are violations according to the provisions in 40CFR§ 63.7935(a) and (b).
[45 CSR 34, 40CFR§63.7935(f)]
- 10.1.19. For each monitoring system required in 40CFR§63.7935, you must develop and make available for inspection by the permitting authority, upon request, a site-specific monitoring plan that addresses the following:
- 10.1.19.1. Installation of the continuous monitoring system probe or other interface at a measurement location relative to each affected process unit such that the measurement is representative of control of the exhaust emissions (e.g., on or downstream of the last control device).
- 10.1.19.2. Performance and equipment specifications for the sample interface, the pollutant concentration or parametric signal analyzer, and the data collection and reduction system.

10.1.19.3. Performance evaluation procedures and acceptance criteria (e.g., calibrations).

10.1.19.4 Continuous monitoring system (CMS) operation and maintenance requirements in accordance with 40CFR§63.7945.

10.1.19.5. CMS data collection in accordance with 40CFR§63.7946.

[45 CSR 34, 40CFR§§63.7935(g)(1-5)]

10.1.20. In your site-specific monitoring plan, you must also address the following:

10.1.20.1. Ongoing operation and maintenance procedures according to the general requirements of 40CFR§§63.8(c)(1)(ii), (c)(3), (c)(4)(ii), (c)(7) and (8).

10.1.20.2. Ongoing data quality assurance procedures according to the general requirements of 40 CFR § 63.8(d) except for the requirements related to startup, shutdown, and malfunction plans referenced in § 63.8(d)(3). The owner or operator shall keep these written procedures on record for the life of the affected source or until the affected source is no longer subject to the provisions of this part, to be made available for inspection, upon request, by the Administrator. If the performance evaluation plan is revised, the owner or operator shall keep previous (*i.e.*, superseded) versions of the performance evaluation plan on record to be made available for inspection, upon request, by the Administrator, for a period of 5 years after each revision to the plan. The program of corrective action should be included in the plan required under 40CFR§ 63.8(d)(2).

10.1.20.3. Ongoing recordkeeping and reporting procedures according to the general requirements of 40CFR§§63.10(c)(1) through (14), (e)(1), and (e)(2)(i).

[45 CSR 34, 40CFR§§63.7935(h)(1-3)]

10.1.21. You must operate and maintain the continuous monitoring system according to the site-specific monitoring plan.

[45 CSR 34, 40CFR§63.7935(i)]

10.1.22. You must conduct a performance evaluation of each continuous monitoring according to your site-specific monitoring plan.

[45 CSR 34, 40CFR§63.7935(j)]

10.1.23. If you have a new affected source that manages remediation material other than a radioactive mixed waste as defined in 40C.F.R.§63.7957, then the Permittee must meet the compliance date specified in Condition 10.1.23.1.

10.1.23.1. If the affected source's initial startup date is after October 8, 2003, the Permittee must comply with each emission limitation, work practice standard, and operation and maintenance requirement of 40 C.F.R. 63, Subpart GGGGG that applies upon initial startup.

[45 CSR 34, 40CFR§§63.7883(b) and (b)(2)]

10.1.24. For control device CLB2VGAC, you must:

10.1.24.1. Replace the existing adsorbent in each segment of the bed with an adsorbent that meets the replacement specifications established during the design evaluation before the age of the adsorbent exceeds the maximum allowable age established during the design evaluation.

10.1.24.2. Meet the disposal requirements for spent carbon in 40CFR§63.693(d)(4)(ii).

[45 CSR 34, 40CFR§63.7925(h)(2)]

10.1.25. You must demonstrate continuous compliance with the spent carbon replacement and disposal work practice standards for nonregenerable carbon adsorption systems in 40CFR§63.7925(h)(2) by meeting the following requirements:

10.1.25.1. Replacing the adsorbent as required by the work practices standard in 40CFR§63.7925(h)(2)(i).

10.1.25.2. Following the disposal requirements for spent carbon in 40CFR§63.693(d)(4)(ii).

10.1.25.3. Keeping records to document compliance with the requirements of the work practice standards.

[45 CSR 34, 40CFR§63.7928(f)]

10.2 Monitoring Requirements

10.2.1. You must monitor, inspect, and repair defects of each closed vent system according to the requirements in 40CFR§§63.695(c)(1)(ii) through (c)(3).

[45 CSR 34, 40CFR§63.7927(a)(1)(i)]

10.2.2. If you use a thermal incinerator, you must use a CPMS to measure and record the hourly average firebox temperature and determine and record the daily average firebox temperature.

[45 CSR 34, 40CFR§63.7927(e)]

10.2.3. If you use a catalytic incinerator, you must use a CPMS with two temperature sensors to measure and record the hourly average temperature at the inlet (for MI2CO) and outlet for (MIGCS CO) of the catalyst bed, and to determine and record the daily average temperature of the catalyst bed.

[45 CSR 34, 40CFR§63.7927(f)]

10.2.4. Each CPMS must meet the requirements in paragraphs 10.2.4.1 through 10.2.4.4.

10.2.4.1. Complete a minimum of one cycle of operation for each successive 15-minute period.

10.2.4.2. To calculate a valid hourly value, you must have at least three of four equally spaced data values (or at least two, if that condition is included to allow for periodic calibration checks) for that hour from a CPMS that is not out of control according to the monitoring plan referenced in 40CFR§63.7935.

10.2.4.3. To calculate the average emissions from each averaging period, you must have at least 75 percent of the hourly averages for that period using only block hourly average values that are based on valid data (i.e., not from out-of-control periods).

10.2.4.4. Unless otherwise specified, each CPMS must determine the hourly average of all recorded readings and daily average, if required.

[45 CSR 34, 40 CFR§§63.7945(a)(1-4)]

- 10.2.5. You must record the results of each inspection, calibration, and validation check.
[45 CSR 34, 40CFR§63.7945(b)]
- 10.2.6. You must conduct a performance evaluation for each CPMS according to the requirements in 40CFR§63.8(e) and your site-specific monitoring plan.
[45 CSR 34, 40CFR§63.7945(c)]
- 10.2.7. Failure to meet the requirements of 10.2.4.1 through 10.2.4.4. of this section is a deviation and must be reported according to the requirements in 40CFR§63.7951(b)(7).
[45 CSR 34, 40CFR§63.7945(d)]
- 10.2.8. You must monitor and collect data according to 10.2.9 and 10.2.10. and your site-specific monitoring plan required in 40CFR§63.7935.
[45 CSR 34, 40CFR§63.7946(a)]
- 10.2.9. Except for monitor malfunctions, associated repairs, and required quality assurance or control activities (including, as applicable, calibration checks and required zero and span adjustments), you must monitor continuously (or collect data at all required intervals) at all times that the affected source is operating.
[45 CSR 34, 40CFR§63.7946(b)]
- 10.2.10. You may not use data recorded during monitoring malfunctions, associated repairs, out of control periods and required quality assurance or control activities in data averages and calculations used to report emissions or operating levels, nor may such data be used in fulfilling a minimum data availability requirement, if applicable. You must use all the data collected during all other periods in assessing the operation of the control device and associated control system.
[45 CSR 34, 40CFR§63.7946(c)]
- 10.2.11. If you use a nonregenerable carbon adsorption system, you must use a CPMS to measure and record the hourly average temperature of the adsorption bed or you must monitor the concentration of organic compounds in the exhaust vent stream according to the requirements of 40CFR§63.693(d)(4)(iii)(A).
[45 CSR 34, 40CFR§63.7927(c)]

10.3 Testing Requirements

- 10.3.1. You must conduct a performance test or design evaluation for each existing affected source within 180 calendar days after the compliance date that is specified in 40 CFR §63.7883 and any time the EPA requires you according to 40 CFR §63.7(a)(3).
[45 CSR 34, 40CFR§63.7940(a), §63.7942]
- 10.3.2. For each work practice standard that applies to you where initial compliance is not demonstrated using a performance test or design evaluation, you must demonstrate initial compliance within 30 calendar days after the compliance date that is specified in 40 CFR §63.7883 for your affected source.
[45 CSR 34, 40CFR§63.7940(b)]
- 10.3.3. For new sources, you must conduct initial performance tests and other initial compliance demonstrations according to the provisions in 40 CFR§63.7(a)(2).
[45 CSR 34, 40CFR§63.7940(c)]

- 10.3.4. You must conduct a performance test or design evaluation to demonstrate initial compliance for each new or existing affected source that is subject to an emission limit in 40 CFR 63, Subpart GGGGG. You must report the results of the performance test or design evaluation according to the requirements in 40 CFR §63.7950(e)(1).
[45 CSR 34, 40CFR§63.7941(a)]
- 10.3.5. If you choose to conduct a performance test to demonstrate initial compliance, you must conduct the test according to the requirements in 40 CFR §63.7(e)(1) and §63.7941(b)(1) through (5).
[45 CSR 34, 40CFR§63.7941(b)]
- 10.3.6. If you use a vapor incinerator to meet an emission limit in 40 CFR 63, Subpart GGGGG, you may choose to perform a design evaluation to demonstrate initial compliance instead of a performance test. You must perform a design evaluation according to the general requirement in 40 CFR §63.693(b)(8) and the specific requirements in 40 CFR §63.693(f)(2)(ii) for a vapor incinerator.
[45 CSR 34, 40CFR§63.7941(c)]
- 10.3.7. During the performance test or design evaluation, you must collect the appropriate operating parameter monitoring system data, average the operating parameter data over each test run, and set operating limits, whether a minimum or maximum value, based on the average of values for each of the three test runs. If you use a control device design analysis to demonstrate control device performance, then the minimum or maximum operating parameter value must be established based on the control device design analysis and supplemented, as necessary, by the control device manufacturer recommendation or other applicable information.
[45 CSR 34, 40 CFR§63.7941(d)]
- 10.3.8. For each initial compliance demonstration that requires a performance test or design evaluation, you must report the results in your notification of compliance status according to the requirements in 40 CFR §63.7950(e)(1). For each initial compliance demonstration that does not require a performance test or design evaluation, you must submit a notification of compliance status according to the requirements of 40 CFR §63.7950(e)(2).
[45 CSR 34, 40CFR§63.7941(m)]

10.4 Recordkeeping Requirements

- 10.4.1. The permittee must keep the following records:
- 10.4.1.1 A copy of each notification and report that you submitted to comply with this subpart, including all documentation supporting any Initial Notification or Notification of Compliance Status that you submitted, according to the requirements in 40CFR§63.10(b)(1) and (b)(2)(xiv).
- 10.4.1.2. You must continue to keep any records specified in 40CFR§63.6(e)(3)(iii) through (v) related to startup, shutdown, and malfunction.
- 10.4.1.3. For each deviation from an emissions limitation (including an operating limit) or work practice standard occurring at an affected source, you must record information on the number of deviations. For each deviation, include the date, time, and duration, a list of the affected sources or equipment, an estimate of the quantity of each regulated pollutant emitted over any emission limit, a description of the method used to estimate the emissions, the actions taken to minimize emissions, the cause of the deviation (including unknown cause), as applicable, and the corrective actions taken to return the affected unit to its normal or usual manner of operation.

- 10.4.1.4. Records of the number of pressure release events during each calendar year and the number of those events for which the cause was determined to be a force majeure event. Keep these records for the current calendar year and the past 5 calendar years.
- 10.4.1.5. (i) For pressure tank closure devices, as specified in 40CFR§ 63.7895(d)(4), keep records of each release to the atmosphere, including the information specified in paragraphs (a)(7)(iii)(A) through (G) of this section.
- (ii) For each closed vent system that includes bypass devices that could divert a stream away from the control device and into the atmosphere, as specified in 40CFR§ 63.7927(a)(2), and each open-ended valve or line in an emergency shutdown system which is designed to open automatically in the event of a process upset, as specified in 40CFR § 63.1014(c) or § 63.1033(c), keep records of each release to the atmosphere, including the information specified in paragraphs (a)(7)(iii)(A) through (G) of this section.
- (iii)
- (A) The source, nature, and cause of the release.
- (B) The date, time, and duration of the release.
- (C) An estimate of the quantity of HAP listed in Table 1 of this subpart emitted during the release and the calculations used for determining this quantity.
- (D) The actions taken to prevent this release.
- (E) The measures adopted to prevent future such release.
- (F) Hourly records of whether the bypass flow indicator specified under § 63.7927(a)(2)(i) was operating and whether a diversion was detected at any time during the hour, as well as records of the times of all periods when the vent stream is diverted from the control device or the flow indicator is not operating.
- (G) Where a seal mechanism is used to comply with § 63.7927(a)(2)(ii), hourly records of flow are not required. In such cases, you must record that the monthly visual inspection of the seals or closure mechanism has been done and record the duration of all periods when the seal mechanism is broken, the bypass line valve position has changed, or the key for a lock-and-key type lock has been checked out, and records of any car-seal that has broken.
- 10.4.1.6. A record of the fluid level at the beginning and end of each maintenance period during which the tank is subject to § 63.7925(b)(3).
- 10.4.1.7. Results of performance tests and performance evaluations as required by § 63.10(b)(2)(viii).
- 10.4.1.8. The records of initial and ongoing determinations for affected sources that are exempt from control requirements under this subpart.

[45 CSR 34, 40CFR§63.7952(a)(1) through (3) and (6) through (10)]

- 10.4.2. For each continuous monitoring system, the permittee must keep the following records:
- 10.4.2.1. Records described in 40 CFR §63.10(b)(2)(vi) through (xi) that apply to your continuous monitoring system.
- 10.4.2.2. Performance evaluation plans, including previous (i.e., superseded) versions of the plan as required in 40 CFR §63.8(d)(3).

[45 CSR 34, 40 CFR§63.7952(b)]

- 10.4.3. The permittee must keep the records required by 40 CFR 63, Subpart GGGGG to show continuous compliance with each emissions limitation, work practice standard, and operation and maintenance requirement that applies.

[45 CSR 34, 40 CFR§63.7952(c)]

- 10.4.4. You must record, on a semiannual basis, the information in 40 CFR §63.696(g) for planned routine maintenance of a control device for emissions from process vents.

[45 CSR 34, 40 CFR§63.7952(d)]

- 10.4.5. Any records required to be maintained by this part that are submitted electronically via the EPA's CEDRI may be maintained in electronic format. This ability to maintain electronic copies does not affect the requirement for facilities to make records, data, and reports available upon request to a delegated air agency or the EPA as part of an on-site compliance evaluation.

[45 CSR 34, 40 CFR§63.7952(e)]

- 10.4.6. The permittee must maintain files of all information (including all reports and notifications) required by 40 CFR 63, Subpart GGGGG recorded in a form suitable and readily available for expeditious inspection and review. The files must be retained for at least 5 years following the date of each occurrence, measurement, maintenance, corrective action, report, or records. At a minimum, the most recent 2 years of data must be retained on site. The remaining 3 years of data may be retained off site. Such files may be maintained on microfilm, on a computer, on computer floppy disks, on magnetic take disks, or on microfiche.

[45 CSR 34, 40 CFR§§63.7953(a-c)]

- 10.4.7. If, after the remediation activity is completed, there is no other remediation activity at the facility, and the permittee is no longer the owner of the facility, you may keep all records for the completed remediation activity at an off-site location provided you notify the Administrator in writing of the name, address, and contact person for the off-site location.

[45 CSR 34, 40 CFR§63.7953(d)]

10.5 Reporting Requirements

- 10.5.1. The permittee must submit all of the notifications in 40 CFR §63.7 (b) and (c), 63.8(e), 63.8(f)(4) and (6), and 63.9(b) through (h) that apply to you.

[45 CSR 34, 40 CFR§63.7950(a)]

- 10.5.2. As specified in 40 CFR §63.9(b)(3), if you start up your new or reconstructed affected source on or after the effective date, you must submit an Initial Notification not later than 120 calendar days after initial startup.

[45 CSR 34, 40 CFR§63.7950(c)]

- 10.5.3. If the permittee is required to conduct a performance test, you must submit a notification of intent to conduct a performance test at least 60 calendar days before the performance test is scheduled to begin as required in 40 CFR §63.7(b)(1).

[45 CSR 34, 40 CFR§63.7950(d)]

- 10.5.4. For each initial compliance demonstration that includes a performance test or design evaluation, the permittee must submit the Notification of Compliance Status, including the performance test results, before the close of

business on the 60th calendar day following the completion of the performance test according to 40 CFR §63.10(d)(2). You must submit the complete design evaluation and supporting documentation.
[45 CSR 34, 40 CFR§63.7950(e)(1)]

10.5.5. For each initial compliance demonstration that does not include a performance test, you must submit the Notification of Compliance Status before the close of business on the 30th calendar day following the completion of the initial compliance demonstration.
[45 CSR 34, 40 CFR§63.7950(e)(2)]

10.5.6. The permittee must submit a semiannual compliance report according to the following requirements:

10.5.6.1. The first compliance report must cover the period beginning on the compliance date that is specified for your affected source in 40 CFR §63.7883 and ending on June 30 or December 31, whichever date comes first after the compliance date that is specified for your affected source.

10.5.6.2. The first compliance report must be postmarked or delivered no later than July 31 or January 31 whichever date comes first after your first compliance report is due.

10.5.6.3. Each subsequent compliance report must cover the semiannual reporting period from January 1 through June 30 or the semiannual reporting period from July 1 through December 31.

10.5.6.4. Each subsequent compliance report must be postmarked or delivered no later than July 31 or January 31, whichever date comes first after the end of the semiannual reporting period.

10.5.6.5. For each affected source that is subject to permitting regulations pursuant to 40 CFR part 70 or 40 CFR part 71, and if the permitting authority has established dates for submitting semiannual reports pursuant to 40 CFR §70.6(a)(3)(iii)(A), you may submit the first and subsequent compliance reports according to the dates the permitting authority has established instead of the dates specified in paragraphs 10.5.6.1 through 10.5.6.4 of this section.

[45 CSR 34, 40 CFR§63.7951(a)]

10.5.7. Each compliance report must include the following information:

10.5.7.1. Company name and address.

10.5.7.2. Statement by a responsible official with that official's name, title, and signature, certifying the truth, accuracy, and completeness of the content of the report.

10.5.7.3. Date of report and beginning and ending dates of the reporting period.

10.5.7.4. If there were no deviations from any emissions limitations (including operating limit), work practice standards, or operation and maintenance requirements, a statement that there were no deviations from the emissions limitations, work practice standards, or operation and maintenance during the reporting period.

10.5.7.5. If there were no periods during which a continuous monitoring system (including a CPMS or CEMS) was out-of-control as specified by 40 CFR §63.8(c)(7), a statement that there were no periods during which the CPMS was out-of-control during the reporting period.

10.5.7.6. For each deviation from an emissions limitation (including an operating limit) that occurs at affected source for which you are not using a continuous monitoring system (including a CPMS or CEMS) to comply with an emissions limitation or work practice standard required in this subpart, the compliance report must contain the information specified in 10.5.7.1 through 10.5.7.3 and (i) and (ii) of this section.

(i) The total operating time of each affected source during the reporting period.

(ii) Information on the number of deviations. For each deviation, include the date, time, and duration, a list of the affected sources or equipment, an estimate of the quantity of each regulated pollutant emitted over any emission limit, a description of the method used to estimate the emissions, the actions taken to minimize emissions, the cause of the deviation (including unknown cause), as applicable, and the corrective actions taken to return the affected unit to its normal or usual manner of operation.

10.5.7.7. For each deviation from an emissions limitation (including an operating limit) or work practice standard occurring at an affected source where you are using a continuous monitoring system (including a CPMS or CEMS) to comply with the emissions limitations or work practice standard in this subpart, you must include the information specified in 10.5.7.1 through 10.5.7.3 and (a) through (k) of this section.

a. Information on the number of deviations. For each deviation, include the date, time, and duration, a list of the affected sources or equipment, an estimate of the quantity of each regulated pollutant emitted over any emission limit, a description of the method used to estimate the emissions, the actions taken to minimize emissions, the cause of the deviation (including unknown cause), as applicable, and the corrective actions taken to return the affected unit to its normal or usual manner of operation.

b. The date and time that each continuous monitoring system was inoperative, except for zero (low-level) and high-level checks.

c. The date, time, and duration that each continuous monitoring system was out-of-control including the information in 40 CFR §63.8(c)(8).

d. For each deviation caused when the daily average value of a monitored operating parameter is less than the minimum operating parameter limit (or, if applicable, greater than the maximum operating parameter limit), the report must include the daily average values of the monitored parameter, the applicable operating parameter limit, and the date and duration of the period that the deviation occurred. For each deviation caused by lack of monitoring data, the report must include the date and duration of period when the monitoring data were not collected and the reason why the data were not collected.

e. A summary of the total duration of the deviations during the reporting period and the total duration as a percent of the total source operating time during that reporting period.

f. A breakdown of the total duration of the deviations during the reporting period into those that are due to control equipment problems, process problems, other known causes, and unknown causes.

g. A summary of the total duration of continuous monitoring system downtime during the reporting period and the total duration of continuous monitoring system downtime as a percent of the total source operating time during the reporting period.

h. A brief description of the process units.

- i. A brief description of the continuous monitoring system.
- j. The date of the latest continuous monitoring system certification or audit.
- k. A description of any changes in continuous monitoring systems, processes, or controls since the last reporting period.

[45 CSR 34, 40 CFR §63.7951(b)]

- 10.5.8. Part 70 monitoring report. If you have obtained a title V operating permit for an affected source pursuant to 40 CFR part 70 or 40 CFR part 71, you must report all deviations as defined in this subpart in the semiannual monitoring report required by 40 CFR 70.6(a)(3)(iii)(A) or 40 CFR 71.6(a)(3)(iii)(A). If you submit a compliance report for an affected source along with, or as part of, the semiannual monitoring report required by 40 CFR 70.6(a)(3)(iii)(A) or 40 CFR 71.6(a)(3)(iii)(A), and the compliance report includes all the required information concerning deviations from any emissions limitation or operation and maintenance requirement in this subpart, submission of the compliance report satisfies any obligation to report the same deviations in the semiannual monitoring report. However, submission of a compliance report does not otherwise affect any obligation you may have to report deviations from permit requirements for an affected source to your permitting authority.

[45 CSR 34, 40 CFR §63.7951(d)]

- 10.5.9. Performance Test and CMS Performance Evaluation Reports. Within 60 days after the date of completing each performance test or continuous monitoring system (CMS) performance evaluation (as defined in § 63.2) required by this subpart, the owner or operator must submit the results of the performance test or performance evaluation according to the manner specified by either paragraph (1) or (2) of this section.

- (1) Data collected using test methods supported by the EPA's Electronic Reporting Tool (ERT) as listed on the EPA's ERT website (<https://www.epa.gov/electronic-reporting-air-emissions/electronic-reporting-tool-ert>) at the time of the test.

Submit the results of the performance test or the performance evaluation of CMS measuring relative accuracy test audit (RATA) pollutants to the EPA via the Compliance and Emissions Data Reporting Interface (CEDRI), which can be accessed through the EPA's Central Data Exchange (CDX) (<https://cdx.epa.gov/>). The data must be submitted in a file format generated through the use of the EPA's ERT. Alternatively, you may submit an electronic file consistent with the extensible markup language (XML) schema listed on the EPA's ERT website.

- (2) Data collected using test methods that are not supported by the EPA's ERT as listed on the EPA's ERT website at the time of the test. The results of the performance test or the performance evaluation of CMS measuring RATA pollutants by methods that are not supported by the ERT must be included as an attachment in the ERT or an alternate electronic file consistent with the XML schema listed on the EPA's ERT website. The results of the performance test or the performance evaluation of CMS measuring RATA pollutants by methods that are not supported by the ERT, must be included as an attachment in the ERT or an alternate electronic file consistent with the XML schema listed on the EPA's ERT website. Submit the ERT generated package or alternative file to the EPA via CEDRI.

[45 CSR 34, 40 CFR §63.7951(e)]

- 10.5.10 Submitting reports electronically. If you are required to submit reports following the procedure specified in this paragraph, you must submit reports to the EPA via CEDRI, which can be accessed through the EPA's CDX (<https://cdx.epa.gov/>). You must use the appropriate electronic report template on the CEDRI website (<https://www.epa.gov/electronic-reporting-air-emissions/compliance-and-emissions-data-reporting-interface-cedri>) for this subpart. The report must be submitted by the deadline specified in this subpart, regardless of the

method in which the report is submitted. If you claim some of the information required to be submitted via CEDRI is confidential business information (CBI), submit a complete report, including information claimed to be CBI, to the EPA. The report must be generated using the appropriate form on the CEDRI website. Submit the file on a compact disc, flash drive, or other commonly used electronic storage medium and clearly mark the medium as CBI. Mail the electronic medium to U.S. EPA/OAQPS/CORE CBI Office, Attention: Group Leader, Measurement Policy Group, MD C404-02, 4930 Old Page Rd., Durham, NC 27703. The same file with the CBI omitted must be submitted to the EPA via the EPA's CDX as described earlier in this paragraph.

[45 CSR 34, 40 CFR §63.7951(f)]

10.5.11. Claims of EPA system outage. If you are required to electronically submit a report through CEDRI in the EPA's CDX, you may assert a claim of EPA system outage for failure to timely comply with the reporting requirement. To assert a claim of EPA system outage, you must meet the requirements outlined in paragraphs (1) through (7) of this section.

- (1) You must have been or will be precluded from accessing CEDRI and submitting a required report within the time prescribed due to an outage of either the EPA's CEDRI or CDX systems.
- (2) The outage must have occurred within the period of time beginning five business days prior to the date that the submission is due.
- (3) The outage may be planned or unplanned.
- (4) You must submit notification to the Administrator in writing as soon as possible following the date you first knew, or through due diligence should have known, that the event may cause or has caused a delay in reporting.
- (5) You must provide to the Administrator a written description identifying:
 - (i) The date(s) and time(s) when CDX or CEDRI was accessed and the system was unavailable;
 - (ii) A rationale for attributing the delay in reporting beyond the regulatory deadline to EPA system outage;
 - (iii) Measures taken or to be taken to minimize the delay in reporting; and
 - (iv) The date by which you propose to report, or if you have already met the reporting requirement at the time of the notification, the date you reported.
- (6) The decision to accept the claim of EPA system outage and allow an extension to the reporting deadline is solely within the discretion of the Administrator.
- (7) In any circumstance, the report must be submitted electronically as soon as possible after the outage is resolved.

[45 CSR 34, 40 CFR §63.7951(g)]

10.5.12. Claims of force majeure. If you are required to electronically submit a report through CEDRI in the EPA's CDX, you may assert a claim of force majeure for failure to timely comply with the reporting requirement. To assert a claim of force majeure, you must meet the requirements outlined in paragraphs (1) through (5) of this section.

- (1) You may submit a claim if a force majeure event is about to occur, occurs, or has occurred or there are lingering effects from such an event within the period of time beginning five business days prior to the date the submission is due. For the purposes of this section, a force majeure event is defined as an event that will be or has been caused by circumstances beyond the control of the affected facility, its contractors, or any entity controlled by the affected facility that prevents you from complying with the requirement to submit a report electronically within the time period prescribed. Examples of such events are acts of nature (*e.g.*,

hurricanes, earthquakes, or floods), acts of war or terrorism, or equipment failure or safety hazard beyond the control of the affected facility (*e.g.*, large scale power outage).

- (2) You must submit notification to the Administrator in writing as soon as possible following the date you first knew, or through due diligence should have known, that the event may cause or has caused a delay in reporting.
- (3) You must provide to the Administrator:
 - (i) A written description of the force majeure event;
 - (ii) A rationale for attributing the delay in reporting beyond the regulatory deadline to the force majeure event;
 - (iii) Measures taken or to be taken to minimize the delay in reporting; and
 - (iv) The date by which you propose to report, or if you have already met the reporting requirement at the time of the notification, the date you reported.
- (4) The decision to accept the claim of force majeure and allow an extension to the reporting deadline is solely within the discretion of the Administrator.
- (5) In any circumstance, the reporting must occur as soon as possible after the force majeure event occurs.

[45 CSR 34, 40 CFR §63.7951(h)]

10.5.13. The Permittee must meet the notification requirements, according to the schedule applicable as specified in 40 C.F.R. §63.7950 and in 40 C.F.R. part 63, subpart A. Some of the notifications must be submitted before the Permittee is required to comply with the emission limitations and work practice standards in 40 C.F.R. 63, Subpart GGGGG.

[45 CSR 34, 40 CFR §63.7883(e)]

11.0. Source-Specific Requirements for [Groundwater/Soil Remediation Process, Emission Point ID (SVE1, SVE2, SVE3, and MI2VE2)]

11.1. Limitations and Standards

11.1.1. All emissions of regulated pollutants from the Chlorohydrin (Area 42) Vapor Extractive System (A42VE) shall be routed to the Thermal Oxidizer (A42INC).

[45CSR13, Permit Number R13-2840, Condition 4.1.1, Emission Point ID (SVE1)]

11.1.2 All emissions of regulated pollutants from the Thermal Oxidizer shall be routed to the Packed Bed Scrubber (A42PBS).

[45CSR13, Permit Number R13-2840, Condition 4.1.2, Emission Point ID (SVE1)]

11.1.3 Criteria pollutant emissions vented from the Packed Bed Scrubber A42PBS shall not exceed the following:

Criteria Pollutant	lb/hr	tpy
NO _x	0.10	0.44
CO	0.44	1.92
SO ₂	0.01	0.02
PM	0.01	0.01
VOC	3.46	15.07

[45CSR13, Permit Number R13-2840, Condition 4.1.3, Emission Point ID (SVE1)]

11.1.4 Hazardous Air Pollutant emissions vented from the Packed Bed Scrubber A42PBS shall not exceed the following:

Hazardous Air Pollutant	lb/hr	Tpy
1,1,2-Trichloroethane	0.20	0.84
Vinylidene Chloride	0.15	0.65
Ethylene Dichloride	1.53	6.67
Trichloroethene	0.40	1.70
HCl	0.71 ⁽¹⁾	3.33 ⁽²⁾
Other Organic HAPs	0.46	1.61
Total HAPs	3.44	14.79

(1) Except when scrubber maintenance (acid-washing) is being performed (see 11.1.15 and 11.1.16).

(2) 3.10 tpy of HCl emissions emitted during normal scrubber operation plus 0.23 tpy of HCl emissions emitted during scrubber maintenance (acid-washing) (see 11.1.15 and 11.1.16).

[45CSR13, Permit Number R13-2840, Condition 4.1.4, Emission Point ID (SVE1)]

- 11.1.5 The regenerative thermal oxidizer shall be designed, operated and maintained so as to reduce emissions of VOCs by at least 98% or to less than 3.46 pounds per hour.
- 11.1.5.1 The thermal oxidizer shall be operated with a firebox temperature of at least 1400F at all times when the contaminated vent gas is being combusted. Compliance with this requirement shall be based on a daily average.
[45CSR13, Permit Number R13-2840, Condition 4.1.5, Emission Point ID (SVE1)]
- 11.1.6 The packed bed scrubber shall be designed, operated and maintained so as to reduce emissions of HCl by at least 99.5% or to no more than 0.71 pounds per hour except when scrubber maintenance (acid-washing) is being performed.
- 11.1.6.1 The packed bed scrubber shall be operated with a daily average pH of the inlet liquid of at least 7.0 when the contaminated vent gas is being combusted except that during periods of scrubber maintenance (acid-washing), the pH of the inlet liquid shall not be included in this daily average.
[45CSR13, Permit Number R13-2840, Condition 4.1.6, Emission Point ID (SVE1)]
- 11.1.7 Visible emissions from the thermal oxidizer (TO-1) shall not exceed twenty percent (20%) opacity except that an opacity level of up to forty percent (40%) is permitted during startup periods during the first eight (8) minutes of operation of the unit.
[45CSR13, Permit Number R13-2840, Condition 4.1.7, Emission Point ID (SVE1)]
[45CSR§6-4.3.] & [45CSR§6-4.4.]
- 11.1.8. **Operation and Maintenance of Air Pollution Control Equipment.** The permittee shall, to the extent practicable, install, maintain, and operate all pollution control equipment listed in Section 1.0 and associated monitoring equipment in a manner consistent with safety and good air pollution control practices for minimizing emissions, or comply with any more stringent limits set forth in this permit or as set forth by any State rule, Federal regulation, or alternative control plan approved by the Secretary.
[45CSR13, Permit Number R13-2840, Condition 4.1.8, Emission Point ID (SVE1, SVE3)]
[45CSR13, Permit Number R13-3025, Condition 4.1.7, Emission Point ID (MI2VE2)]
[45CSR§13-5.10.]
- 11.1.9. All emissions of regulated pollutants from the Vapor Extractive System (MI2VE) shall be routed to the Catalytic Oxidizer (MI2CO).
[45CSR13, Permit Number R13-3025, Condition 4.1.1, Emission Point ID (MI2VE2)]
- 11.1.10. Criteria pollutant emissions vented from the Catalytic Oxidizer MI2CO shall not exceed the following:

Pollutant	lb/hr	Tpy
NO _x	0.01	0.01
CO	0.01	0.01
SO ₂	0.01	0.02
PM	0.01 ¹	0.01
VOC	0.46	1.24

¹Compliance with this limit will ensure compliance with the less stringent limit in 45CSR§6-4.1
[45CSR§6-4.1]
[45CSR13, Permit Number R13-3025, Condition 4.1.2, Emission Point ID (MI2VE2)]

- 11.1.11. Hazardous Air Pollutant emissions vented from the Catalytic Oxidizer MI2CO shall not exceed the following:

Pollutant	lb/hr	tpy
Hexane	0.07	0.23
Benzene	0.13	0.42
Total HAPs	0.30	0.87

[45CSR13, Permit Number R13-3025, Condition 4.1.3. Emission Point ID (MI2VE2)]

- 11.1.12. The catalytic oxidizer shall be designed, operated and maintained so as to reduce emissions in accordance with the emission limits specified in conditions 11.1.10 and 11.1.11.

11.1.12.1. The catalytic oxidizer shall be operated with a combustion chamber temperature of at least the 650 °F at all times when the contaminated vent gas is being combusted. Compliance with this requirement shall be based on a daily average

[45CSR13, Permit Number R13-3025, Condition 4.1.4. Emission Point ID (MI2VE2)]

- 11.1.13. Visible emissions from the catalytic oxidizer MI2CO shall not exceed twenty percent (20%) opacity except that an opacity level of up to forty percent (40%) is permitted during startup periods during the first eight (8) minutes of operation of the unit.

[45CSR13, Permit Number R13-3025, Condition 4.1.5. Emission Point ID (MI2VE2)]

[45CSR§6-4.3.] & [45CSR§6-4.4.]

- 11.1.14. Catalyst shall be replaced in accordance with manufacturer specifications.

[45CSR13, Permit Number R13-3025, Condition 4.1.6. Emission Point ID (MI2VE2)]

- 11.1.15. Scrubber maintenance (acid-washing) shall be conducted no more than 12 times per year and shall be limited to no more than six (6) hours per each cleaning activity/event.

[45CSR13, Permit Number R13-2840, Condition 4.1.9, Emission Point ID (SVE1)]

- 11.1.16. HCl emissions resulting from scrubber maintenance (acid-washing) shall not exceed 37.65 pounds per event and 0.23 tons per year.

[45CSR13, Permit Number R13-2840, Condition 4.1.10, Emission Point ID (SVE1)]

- 11.1.17. Average total volatile organic hazardous air pollutant (VOHAP) concentration, as defined in 40.C.F.R. §63.7957 shall be less than 10 parts per million by weight (ppmw) during times when CLBVE is vented through emission point SVE2. Determination of the VOHAP concentration is made using the procedures specified in 40 C.F.R. §63.7943.

[40 C.F.R. §63.7885(b)(2); 45CSR34, 45CSR13, Permit Number R13-2840, Condition 4.1.11, Emission Point ID (SVE2)]

- 11.1.18 Emissions of regulated pollutants from the Chlorobenzene Area 2 Vapor Extraction System (CLB2VE) shall be routed to the vapor phase granular activated carbon vessels (CLB2VGAC).

[Permit Number R13-2840, Condition 4.1.12, Emission Point ID SVE3]

11.1.19. Pollutant emissions vented from CLB2VGAC shall not exceed the following:

Pollutant	Lb/hr	tpy
Ethylbenzene	0.01	0.01
Xylene	0.01	0.01
Naphthalene	0.08	0.17
Total VOC/HAPs	0.10	0.19

[Permit Number R13-2840, Condition 4.1.13, Emission Point ID SVE3]

11.1.20. The CLB2VE closed-vent system shall be designed to operate with no detectable organic emissions using the procedure specified in 40 C.F.R. §63.695(c)(2) and monitoring as specified in 40 C.F.R. §63.7928(b)(2).

[45CSR34; 40 C.F.R. §63.7925(c); Permit Number R13-2840, Condition 4.1.14, Emission Point ID SVE3]

11.1.21. Carbon replacement for the vapor phase granular activated carbon vessels (CLB2VGAC) shall be performed at the frequency determined during the initial design evaluation or when monitoring indicates breakthrough has occurred.

[45CSR34; 40 C.F.R. §63.7925(h)(2)(i); Permit Number R13-2840, Condition 4.1.15, Emission Point ID SVE3]

11.2. Testing Requirements

11.2.1. Reserved.

11.2.2 At least monthly visual particulate emissions checks of the packed bed scrubber exhaust stack will be conducted. These checks shall be conducted during periods of operation and for a sufficient time interval to determine if the unit has visible emissions using the procedures outlined in 40 CFR 60, Appendix A, Method 22. If no visible emissions are noted during four consecutive monthly observation periods, visual emissions checks will be conducted quarterly commencing with the next calendar quarter. If no visible emissions are noted during four consecutive calendar quarters, visual checks may be conducted semiannually. If sources of visible emissions are identified during the survey or at any other time, the permittee shall conduct a 40 CFR 60, Appendix A, Method 9 evaluation within 24 hours and restart monthly visual emission checks. A Method 9 evaluation shall not be required if the visible emission condition is corrected within 24 hours and the incinerator is operated at normal operating conditions. A record of each visible emission check required above shall be maintained on site. Said record shall include but not be limited to, the date, time, name of emission unit, the applicable visible emissions requirement, the results of the check, what action (s), if any, was/were taken, and the name of the observer.

[45CSR13, Permit Number R13-2840, Condition 4.2.2, Emission Point ID (SVE1)]

11.2.3 The pH of the scrubber liquid shall be measured at least once per day and shall exclude measurements taken during times when scrubber maintenance (acid-washing) is being performed.

[45CSR13, Permit Number R13-2840, Condition 4.2.3, Emission Point ID (SVE1)]

11.2.4. For the purposes of demonstrating compliance with visible emissions limitations set forth in condition 11.1.13, the permittee shall:

- a. Conduct Method 22 visible emission observations of the oxidizer stack every 6 months to ensure proper operation for a minimum of ten (10) minutes per observation.
- b. In the event visible emissions are observed in excess of the limitations given in condition 11.1.13, the permittee shall take immediate corrective action.

[45CSR13, Permit Number R13-3025, Condition 4.2.2, Emission Point ID (MI2VE2)]

- 11.2.5. A design evaluation shall be performed on the Chlorobenzene Area 2 vapor extractive system (CLB2VE) in accordance with 40CFR§63.693(d)(2)(ii)(B) within 180 days of startup of operations. The design evaluation shall assess the CLB2VE vent stream composition, constituent concentrations, flow rate relative humidity, and temperature. The evaluation shall establish the design exhaust vent stream organic compound concentration, carbon bed capacity, activated carbon type and working capacity, and design carbon replacement interval based on the total carbon working capacity of the control device and emission point operating schedule.
[45CSR34; 40CFR§63.7940(a), 45CSR13, Permit Number R13-2840, Condition 4.2.4.]

11.3. Monitoring and Recordkeeping Requirements

- 11.3.1. **Record of Monitoring.** The permittee shall keep records of monitoring information that include the following:

- a. The date, place as defined in this permit and time of sampling or measurements;
- b. The date(s) analyses were performed;
- c. The company or entity that performed the analyses;
- d. The analytical techniques or methods used;
- e. The results of the analyses; and
- f. The operating conditions existing at the time of sampling or measurement.

[45CSR13, Permit Number R13-2840, Condition 4.3.1, Emission Point ID (SVE1, SVE3)]
[45CSR13, Permit Number R13-3025, Condition 4.3.1, Emission Point ID (MI2VE2)]

- 11.3.2. **Record of Maintenance of Air Pollution Control Equipment.** For all pollution control equipment listed in Section 1.0, the permittee shall maintain accurate records of all required pollution control equipment inspection and/or preventative maintenance procedures.

[45CSR13, Permit Number R13-2840, Condition 4.3.2, Emission Point ID (SVE1, SVE3)]
[45CSR13, Permit Number R13-3025, Condition 4.3.2, Emission Point ID (MI2VE2)]

- 11.3.3. **Record of Malfunctions of Air Pollution Control Equipment.** For all air pollution control equipment listed in Section 1.0, the permittee shall maintain records of the occurrence and duration of any malfunction or operational shutdown of the air pollution control equipment during which excess emissions occur. For each such case, the following information shall be recorded:

- a. The equipment involved.
- b. Steps taken to minimize emissions during the event.
- c. The duration of the event.
- d. The estimated increase in emissions during the event.

For each such case associated with an equipment malfunction, the additional information shall also be recorded:

- e. The cause of the malfunction.
- f. Steps taken to correct the malfunction.

- g. Any changes or modifications to equipment or procedures that would help prevent future recurrences of the malfunction.

[45CSR13, Permit Number R13-2840, Condition 4.3.3, Emission Point ID (SVE1, SVE3)]
[45CSR13, Permit Number R13-3025, Condition 4.3.3, Emission Point ID (MI2VE2)]

- 11.3.4. The permittee shall maintain the following records relating to the RTO.

- 11.3.4.1 Daily average firebox temperature. Said average shall be determined by monitoring the temperature every 15 minutes to determine an hourly average and then averaging the days 24 hourly averages.

- 11.3.4.2 Completed maintenance and calibrations.

- 11.3.4.3 Reserved.

- 11.3.4.4 Copy of the site specific monitoring plan. The plan may refer to the manufacturers operation and maintenance manual or other documents for procedures covering operation, maintenance, calibrations and inspections.

- 11.3.4.5 Records of monitoring equipment downtime and corrective actions taken.
[45CSR13, Permit Number R13-2840, Condition 4.3.4, Emission Point ID (SVE1)]

- 11.3.5 The permittee shall maintain the following records relating to the packed bed scrubber.

- 11.3.5.1 Daily average liquid flow rate of the scrubber. Said average shall be determined by monitoring the flow rate every 15 minutes to determine an hourly average and then averaging the day's 24 hourly averages.

- 11.3.5.2 Daily pH of the scrubber liquid as measured in accordance with Condition 11.2.3.

- 11.3.5.3 Completed maintenance and calibrations.

- 11.3.5.4 Copy of the site specific monitoring plan. The plan may refer to the manufacturers' operation and maintenance manual or other documents for procedures covering operation, maintenance, calibrations and inspections.

- 11.3.5.5 Records of monitoring equipment downtime and corrective actions taken.
[45CSR13, Permit Number R13-2840, Condition 4.3.5, Emission Point ID (SVE1)]

- 11.3.6. The permittee shall maintain the following records relating to the electric catalytic oxidizer.

- 11.3.6.1 Daily average combustion chamber temperature. Said average shall be determined by monitoring the temperature every operating hour when contaminated vent gas is being combusted, then averaging the operating hour readings for each calendar day.

- 11.3.6.2 Completed maintenance and calibrations.

- 11.3.6.3 Reserved.

- 11.3.6.4 Copy of the site specific monitoring plan. The plan may refer to the manufacturer's operation and maintenance manual or other documents for procedures covering operation, maintenance, calibrations and inspections.

11.3.6.5 Records of oxidizer combustion chamber temperature monitoring equipment downtime and corrective actions taken.

[45CSR13, Permit Number R13-3025, Condition 4.3.4, Emission Point ID (MI2VE2)]

11.3.7 The permittee shall maintain records of all visual emission observations pursuant to the monitoring required under condition 11.2.4. including any corrective action taken.

[45CSR13, Permit Number R13-3025, Condition 4.3.5, Emission Point ID (MI2VE2)]

11.3.8. To demonstrate compliance with Conditions 11.1.15 and 11.1.16, the Permittee shall record the date and duration of each scrubber maintenance (acid-washing) activity.

[45CSR13, Permit Number R13-2840, Condition 4.3.6, Emission Point ID (SVE1)]

11.3.9. To show compliance with the emission limits in 11.1.19, the permittee shall use the monitoring results collected in accordance with 11.3.10 and recorded operational hours to calculate monthly emissions and a 12 month rolling total.

[45CSR13, Permit Number R13-2840, Condition 4.3.7, Emission Point ID (SVE3)]

11.3.10. To demonstrate compliance with the requirement of 11.1.21, the concentration of organic compounds in the exhaust vent stream of CLB2VGAC shall be monitored according to the requirements in 40 C.F.R. §63.693(d)(4)(iii)(A).

[45CSR34; 40 C.F.R. §63.7927(c); 45CSR13, Permit Number R13-2840, Condition 4.3.8, Emission Point ID (SVE3)]

11.3.11. The permittee shall maintain the following records relating to the CLB2VGAC.

11.3.11.1. Copy of equipment design and installation.

11.3.11.2. Completed maintenance and calibrations.

11.3.11.3. Copy of the site-specific monitoring plan. The plan may refer to the manufacturer's operation and maintenance manual or other documents for procedures covering operation, maintenance, calibrations and inspections, and startup and shutdown, and malfunctions.

11.3.11.4. Copies of all performance tests and design evaluations.

11.3.11.5. Records demonstrating compliance with emission limitations, work practice standards, and operation and maintenance requirements.

[45CSR34; 40 C.F.R. §63.7952(c); 45CSR13, Permit Number R13-2840, Condition 4.3.9, Emission Point ID (SVE3)]

11.4. Reporting Requirements

11.4.1. Semiannual monitoring reports will be submitted on or before September 15 for the reporting period of January 1 to June 30 and on or before March 15 for the reporting period July 1 to December 31. All instances of deviation from the permit requirements will be clearly identified in such reports.

[45CSR13, Permit Number R13-2840, Condition 4.4.1, Emission Point ID (SVE1, SVE3)]

[45CSR13, Permit Number R13-3025, Condition 4.4.1, Emission Point ID (MI2VE2)]

- 11.4.2. An initial notification of compliance status will be submitted for Chlorobenzene Area 2 vapor extraction system to certify the closed vent system was installed and inspected according to the requirements of 40CFR§63.695. The results of the design evaluation and supporting documentation (See 11.2.5) will be included with the certification.

[45CSR34; 40CFR§63.7950(e)(1), 45CSR13, Permit Number R13-2840, Condition 4.4.2]

12.0 Source-Specific Requirements [Chemical Mixing (See Section 1.0 for Equipment List)]

12.1. Limitations and Standards

12.1.1. **MON MACT.** The permittee shall comply with the following emission limits, work practice standards and compliance requirements as specified by §63.2450.

- Rail car loading rack (Rack ID RC050L) and tank truck loading rack (Rack ID TT050L) used to load organic liquids containing hazardous air pollutants shall be operated as Group 2 transfer operations as defined by the MON Rule.

[45CSR34, 40 C.F.R. §63.2450]

12.1.2. **MON MACT.** The permittee shall comply with the applicable general provisions of 40 C.F.R.63 Subpart A as specified by 40 C.F.R. §63.2540 and Table 12 of Subpart FFFF.

[45CSR34, 40 C.F.R. §63.2540; 40 C.F.R. § 63 Table 12 to Subpart FFFF]

12.1.3. **MON MACT.** The permittee shall comply with the applicable equipment leak standards of the MON MACT as specified by 40 C.F.R. §63.2480(b), subpart H of 40 CFR 63, except as specified in 40 C.F.R. §63.2480(f). As a result, the permittee has defined the following schedule within their NOC report.

Phase	Planned Schedule for Implementation On or Before
Phase I – Beginning on the compliance date	May 10, 2008
Phase II – Beginning no later than 1 year after the compliance date	May 10, 2009
Phase III – Beginning no later than 2 ½ years after the compliance date	November 8, 2010

[45CSR34, 40 C.F.R. §63.2480]

12.1.4. **MON MACT.** The permittee shall comply with the following provisions for wastewater streams as specified by 40 C.F.R. §63.2485.

- The permittee shall develop and maintain a maintenance wastewater plan that is implemented per §63.2485(a) and §63.105.

[45CSR34, 40 C.F.R. §63.2485]

12.2. Monitoring Requirements

12.2.1. Reserved.

12.3. Testing Requirements

12.3.1. Reserved.

12.4. Recordkeeping Requirements

12.4.1. **MON MACT.** The permittee shall maintain the following records to demonstrate compliance with the MON and this permit.

- Maintain supporting information used to determine MON initial applicability to process vents, storage vessels, equipment leaks, transfer operations, heat exchangers, process wastewater and in-process aqueous liquid streams.
 - Maintain operating scenarios and calculations of uncontrolled hazardous air pollutant emissions for process vents used to prepare the NOCS.
 - Maintain records of monitoring and inspections results for equipment component leak detection and repair as required by 40 CFR 63, Subpart H.
 - Maintain a record each time a safety device is opened to the air that contains hazardous air pollutants to avoid unsafe conditions.
 - Maintain a copy of the following reports and notifications:
 - Notice of initial notification
 - Notification of compliance status report
 - Semiannual compliance reports including information regarding process changes as specified by §63.2520(e)(10).
- [45CSR34, 40C.F.R.§63.2525]

12.5. Reporting Requirements

12.5.1. **MON MACT.** The permittee shall submit a semiannual compliance report that includes the information specified by §63.2520(e) and the results of equipment leak monitoring and repair conducted per 40 CFR 63 Subpart H.

[45CSR34, 40 C.F.R. §63.2520]

12.6 Compliance Plan

N/A

13.0 Source-Specific Requirements [Emergency Engines under 40 C.F.R. 63, Subpart ZZZZ (RICE); Compressors and Fire Water Pumps, Emission Points: (DP01E, DP02E, DP03E)]

13.1. Limitations and Standards

13.1.1. Reserved.

13.1.2. For emergency stationary CI RICE¹, you must meet the following requirements, except during periods of startup:

- a. Change oil and filter every 500 hours of operation or annually, whichever comes first;²
- b. Inspect air cleaner every 1,000 hours of operation or annually, whichever comes first, and replace as necessary
- c. Inspect all hoses and belts every 500 hours of operation or annually, whichever comes first, and replace as necessary.³

During periods of startup you must minimize the engine's time spent at idle and minimize the engine's startup time at startup to a period needed for appropriate and safe loading of the engine, not to exceed 30 minutes.

¹ If an emergency engine is operating during an emergency and it is not possible to shut down the engine in order to perform the work practice requirements on the schedule required in Table 2c of 40 C.F.R. 63 Subpart ZZZZ, or if performing the work practice on the required schedule would otherwise pose an unacceptable risk under Federal, State, or local law, the work practice can be delayed until the emergency is over or the unacceptable risk under Federal, State, or local law has abated. The work practice should be performed as soon as practicable after the emergency has ended or the unacceptable risk under Federal, State, or local law has abated. Sources must report any failure to perform the work practice on the schedule required and the Federal, State or local law under which the risk was deemed unacceptable.

² Sources have the option to utilize an oil analysis program as described in 40 C.F.R. §63.6625(i) (permit condition 13.1.6.) in order to extend the specified oil change requirement in Table 2c of 40 C.F.R. 63 Subpart ZZZZ.

³ Sources can petition the Administrator pursuant to the requirements of 40 C.F.R. §63.6(g) for alternative work practices.

[40 C.F.R. §63.6602, Table 2c, Row 1; 40 C.F.R. §63.6625(h); 45CSR34, Emission Points (DP01E, DP02E)]

13.1.3. At all times you must operate and maintain any affected source, including associated air pollution control equipment and monitoring equipment, in a manner consistent with safety and good air pollution control practices for minimizing emissions. The general duty to minimize emissions does not require you to make any further efforts to reduce emissions if levels required by this standard have been achieved. Determination of whether such operation and maintenance procedures are being used will be based on information available to the Administrator which may include, but is not limited to, monitoring results, review of operation and maintenance procedures, review of operation and maintenance records, and inspection of the source.

[40 C.F.R. §63.6605(b); 45CSR34, Emission Points (DP01E, DP02E)]

- 13.1.4. If you own or operate an existing emergency stationary RICE with a site rating of less than or equal to 500 HP located at a major source of HAP emissions, you must operate and maintain the stationary RICE and after-treatment control device (if any) according to the manufacturer's emission-related written instructions or develop your own maintenance plan which must provide to the extent practicable for the maintenance and operation of the engine in a manner consistent with good air pollution control practice for minimizing emissions.
[40 C.F.R. §§63.6625(e) and 63.6625(e)(2); 40 C.F.R. §63.6640(a), Table 6, Row 9; 45CSR34, Emission Points (DP01E, DP02E)]
- 13.1.5. If you own or operate an existing emergency stationary RICE with a site rating of less than or equal to 500 brake HP located at a major source of HAP emissions, you must install a non-resettable hour meter if one is not already installed.
[40 C.F.R. §63.6625(f); 45CSR34, Emission Points (DP01E, DP02E)]
- 13.1.6. If you own or operate a stationary CI engine that is subject to the work, operation or management practices in item 1 of Table 2c to 40 C.F.R. 63 Subpart ZZZZ (permit condition 13.1.2.), you have the option of utilizing an oil analysis program in order to extend the specified oil change requirement in Tables 2c to 40 C.F.R. 63 Subpart ZZZZ. The oil analysis must be performed at the same frequency specified for changing the oil in Table 2c to 40 C.F.R. 63 Subpart ZZZZ (permit condition 13.1.2.a.). The analysis program must at a minimum analyze the following three parameters: Total Base Number, viscosity, and percent water content. The condemning limits for these parameters are as follows: Total Base Number is less than 30 percent of the Total Base Number of the oil when new; viscosity of the oil has changed by more than 20 percent from the viscosity of the oil when new; or percent water content (by volume) is greater than 0.5. If all of these condemning limits are not exceeded, the engine owner or operator is not required to change the oil. If any of the limits are exceeded, the engine owner or operator must change the oil within 2 business days of receiving the results of the analysis; if the engine is not in operation when the results of the analysis are received, the engine owner or operator must change the oil within 2 business days or before commencing operation, whichever is later. The owner or operator must keep records of the parameters that are analyzed as part of the program, the results of the analysis, and the oil changes for the engine. The analysis program must be part of the maintenance plan for the engine (permit condition 13.1.4.).
[40 C.F.R. §63.6625(i); 45CSR34, Emission Points (DP01E, DP02E)]
- 13.1.7. *Requirements for emergency stationary RICE.* If you own or operate an emergency stationary RICE, you must operate the emergency stationary RICE according to the requirements in paragraphs 13.1.7.1. through 13.1.7.3 of this section. Any operation other than emergency operation, maintenance and testing, and operation in non-emergency situations for 50 hours per year, as described in paragraphs 13.1.7.1 through 13.1.7.3 of this section, is prohibited. If you do not operate the engine according to the requirements in paragraphs 13.1.7.1 through 13.1.7.3 of this section, the engine will not be considered an emergency engine under this subpart and must meet all requirements for non-emergency engines.
- 13.1.7.1. There is no time limit on the use of emergency stationary RICE in emergency situations.
- 13.1.7.2. You may operate your emergency stationary RICE for the purpose specified in paragraph 13.1.7.2.i for a maximum of 100 hours per calendar year. Any operation for non-emergency situations as allowed by paragraph 13.1.7.3 of this section counts as part of the 100 hours per calendar year allowed by this paragraph 13.1.7.2.
- (i) Emergency stationary RICE may be operated for maintenance checks and readiness testing provided that the tests are recommended by federal, state or local government, the manufacturer, the vendor, the regional transmission organization or equivalent balancing authority and transmission operator, or the insurance company associated with the engine.

The owner or operator may petition the Administrator for approval of additional hours to be used for maintenance checks and readiness testing, but a petition is not required if the owner or operator maintains records indicating that federal, state, or local standards require maintenance and testing of emergency RICE beyond 100 hours per calendar year.

- 13.1.7.3. Emergency stationary RICE located at major sources of HAP may be operated for up to 50 hours per calendar year in non-emergency situations. The 50 hours of operation in non-emergency situations are counted as part of the 100 hours per calendar year for maintenance and testing provided in paragraph 13.1.7.2 of this section. The 50 hours per year for non-emergency situations cannot be used for peak shaving or non-emergency demand response, or to generate income for a facility to supply power to an electric grid or otherwise supply power as part of a financial arrangement with another entity.

[40 C.F.R. §§63.6640(f)(1-3); 45CSR34, Emission Points (DP01E, DP02E, DP03E)]

13.2. Monitoring Requirements

- 13.2.1. Reserved.

13.3. Testing Requirements

- 13.3.1. Reserved.

13.4. Recordkeeping Requirements

- 13.4.1. You must keep records of the maintenance conducted on the stationary RICE in order to demonstrate that you operated and maintained the stationary RICE and after-treatment control device (if any) according to your own maintenance plan (permit condition 13.1.4.) if you own or operate an existing stationary emergency RICE.

[40 C.F.R. §§63.6655(e) and 63.6655(e)(2); 45CSR34, Emission Points (DP01E, DP02E)]

- 13.4.2. If you own or operate an existing emergency stationary RICE with a site rating of less than or equal to 500 brake HP located at a major source of HAP emissions that does not meet the standards applicable to non-emergency engines, you must keep records of the hours of operation of the engine that is recorded through the non-resettable hour meter. The owner or operator must document how many hours are spent for emergency operation, including what classified the operation as emergency and how many hours are spent for non-emergency operation.

[40 C.F.R. §§63.6655(f) and 63.6655(f)(1); 45CSR34, Emission Points (DP01E, DP02E)]

- 13.4.3. **Form and Retention of Records for 40 C.F.R. 63 Subpart ZZZZ.**

(a) Your records must be in a form suitable and readily available for expeditious review according to 40 C.F.R. §63.10(b)(1).

(b) As specified in 40 C.F.R. §63.10(b)(1), you must keep each record for 5 years following the date of each occurrence, measurement, maintenance, corrective action, report, or record.

(c) You must keep each record readily accessible in hard copy or electronic form for at least 5 years after the date of each occurrence, measurement, maintenance, corrective action, report, or record, according to 40 C.F.R. §63.10(b)(1).

[40 C.F.R. §§63.6660(a), (b), and (c); 45CSR34, Emission Points (DP01E, DP02E)]

13.5. Reporting Requirements

- 13.5.1. You must report each instance in which you did not meet each limitation in Table 2c to 40 C.F.R. 63 Subpart ZZZZ (permit condition 13.1.2.). These instances are deviations from the emission and operating limitations in 40 C.F.R. 63 Subpart ZZZZ. These deviations must be reported according to the requirements in 40 C.F.R. §63.6650 (permit condition 13.5.3.).
[40 C.F.R. §63.6640(b); 45CSR34, Emission Points (DP01E, DP02E)]
- 13.5.2. You must also report each instance in which you did not meet the requirements in Table 8 to 40 C.F.R. 63 Subpart ZZZZ that apply to you.
[40 C.F.R. §63.6640(e); 45CSR34, Emission Points (DP01E, DP02E)]
- 13.5.3. The permittee must report all deviations as defined in 40 C.F.R. 63 Subpart ZZZZ in the semiannual monitoring report required by permit condition 3.5.6.
[40 C.F.R. §63.6650(f); 45CSR34, Emission Points (DP01E, DP02E)]

13.6. Compliance Plan

- 13.6.1. Reserved.

14.0 Source-Specific 40 C.F.R. 64 (CAM) Requirements for [Groundwater/Soil Remediation Process, Emission Point ID (SVE1)]

14.1. Limitations and Standards

- 14.1.1. In order to demonstrate compliance with the HCl limitations defined within permit condition 11.1.4, the vapor extraction systems (A42VE and CLBVE) and the packed bed scrubber shall comply with the CAM requirements defined within this section.
[40 C.F.R. 64, Emission Point (SVE1)]

14.2. Monitoring Requirements

- 14.2.1. The permittee shall implement a CAM program for the packed bed scrubber (A42PBS) based on the following performance indicators:
- a. The packed bed scrubber shall be operated in a manner to ensure the daily pH monitoring value of the recirculated scrubber liquor is maintained to a level of at least 7.0, except that during acid-washing maintenance activities, the pH of the system shall not be included in this daily average requirement. Additionally, the scrubber shall maintain a daily average liquor flow to the packed bed of at least 30 gpm. Liquid flow rate shall be monitored continuously, which shall mean at least once every 15 minutes. The accuracy of the pH measuring device shall not exceed plus or minus 0.6 units and the accuracy of the flow meter shall not exceed plus or minus 0.4%.
[40 C.F.R. 64, 45CSR§30-5.1.c]
 - 14.2.2. **Proper Maintenance.** The permittee shall maintain monitoring at all times, including maintaining necessary spare parts for routine repairs of the monitoring equipment. All monitoring devices shall be calibrated in accordance with manufacturer's specifications.
[45CSR§30-5.1.c.; 40 C.F.R. §64.7(b)]
 - 14.2.3. **Response to Excursions or Exceedances.** In accordance with the operation of the packed bed scrubber an excursion shall be defined as any daily average outside of the operating value defined within 14.2.1.
 - a. Upon detecting an excursion or exceedance, the permittee shall restore operation of the pollutant-specific emissions unit (including the control device and associated capture system) to its normal or usual manner of operation as expeditiously as practicable in accordance with good air pollution control practices for minimizing emissions. The response shall include minimizing the period of any startup, shutdown or malfunction and taking any necessary corrective actions to restore normal operation and prevent the likely recurrence of the cause of an excursion or exceedance (other than those caused by excused startup or shutdown conditions). Such actions may include initial inspection and evaluation, recording that operations returned to normal without operator action (such as through response by a computerized distribution control system), or below the applicable emission limitation or standard, as applicable.
 - b. Determination of whether the permittee has used acceptable procedures in response to an excursion or exceedance will be based on information available, which may include, but is not limited to, monitoring results, review of operation and maintenance procedures and records, and inspection of the control device, associated capture system, and the process.
[40 C.F.R. §64.7(d); 45CSR§30-5.1.c.]

- 14.2.4. **Documentation of Need for Improved Monitoring** - After approval of monitoring under 40 C.F.R. Part 64, if the permittee identifies a failure to achieve compliance with an emission limitation or standard for which the approved monitoring did not provide an indication of an excursion or exceedance while providing valid data, or the result of compliance or performance testing/design evaluation document a need to modify the existing indicator ranges or designated conditions, the permittee shall promptly notify the Director and, if necessary, submit a proposed modification to the permit to address the necessary monitoring changes. Such a modification may include, but is not limited to, reestablishing indicator ranges or designated conditions, modifying the frequency of conducting monitoring and collecting data, or the monitoring of additional parameters.

[40 C.F.R. §64.7(e); 45CSR§30-5.1.c.]

14.2.5. **Quality Improvement Plan (QIP)**

- a. Based on the results of a determination made under permit condition 14.2.3.b, 14.2.5.b, or 14.2.5.c the Administrator or the Director may require the permittee to develop and implement a QIP. If a QIP is required, it shall be developed, implemented, and modified as required according to 40 C.F.R. §§64.8(b) through (e). Refer to permit condition 14.5.1(b)(iii) for the reporting required when a QIP is implemented.
- b. If five (5) percent or greater of the unit operating time, is documented as monitoring downtime of the scrubber liquid flow rate measuring device, as identified in Condition 14.2.1.a, during a calendar quarter, the permittee shall develop and implement a QIP. The Director may waive this QIP requirement upon a demonstration that the cause(s) of reduced data availability have been corrected.
- c. If the permittee observes an excursion of any daily average operating value for the packed bed scrubber for three or more days during a calendar quarter, the permittee shall develop and implement a QIP. The Director may waive this QIP requirement upon a demonstration that the cause(s) of excursions have been corrected.

[40 C.F.R. §§ 64.8 and 64.7(d); 45CSR§30-5.1.c.]

- 14.2.6. **Continued Operation.** Except for, as applicable, monitoring malfunctions, associated repairs, and required quality assurance or control activities (including, as applicable, calibration checks and required zero and span adjustments), the owner or operator shall conduct all monitoring in continuous operation (or shall collect data at all required intervals) at all times that the pollutant-specific emissions unit is operating. Data recorded during monitoring malfunctions, associated repairs, and required quality assurance or control activities shall not be used for purposes of this part, including data averages and calculations, or fulfilling a minimum data availability requirement, if applicable. The owner or operator shall use all the data collected during all other periods in assessing the operation of the control device and associated control system. A monitoring malfunction is any sudden, infrequent, not reasonably preventable failure of the monitoring to provide valid data. Monitoring failures that are caused in part by poor maintenance or careless operation are not malfunctions.

[40 C.F.R. §64.7(c); 45CSR§30-5.1.c.]

14.3. Testing Requirements

- 14.3.1. Reserved.

14.4. Recordkeeping Requirements

14.4.1. As part of the CAM plan the permittee shall keep an up-to-date, readily-accessible record of the following information:

- a. Continuous records of the scrubber liquor flow rate; and daily averages. Any min/max flow determinations made during compliance testing and/or design analysis.
- b. Daily records of pH monitoring results; and if utilized daily averages. Any min/max pH determinations made during compliance testing and/or design analysis.

[40 C.F.R.§64.9(b), 45CSR§30-5.1.c, Emission Point ID (SVE1)]

14.4.2. Reserved.

14.4.3. General Recordkeeping Requirements for 40 C.F.R. Part 64 (CAM)

The permittee shall comply with the recordkeeping requirements specified in permit conditions 3.4.1. and 3.4.2.

The permittee shall maintain records of monitoring data, monitoring performance data, corrective actions taken, any written quality improvement plan required pursuant to 40 C.F.R. §64.8 (condition 14.2.5.) and any activities maintained under 40 C.F.R. Part 64 (such as data used to document the adequacy of monitoring, or records of monitoring maintenance or corrective actions).

[40 C.F.R. §64.9(b); 45CSR§30-5.1.c.]

14.5. Reporting Requirements

14.5.1. General Reporting Requirements for 40 C.F.R. Part 64 (CAM)

- a. On and after the date specified in 40 C.F.R. §64.7(a) by which the permittee must use monitoring that meets the requirements of 40 C.F.R. 64, the permittee shall submit monitoring reports to the DAQ in accordance with permit condition 3.5.5.
- b. A report for monitoring under 40 C.F.R. 64 shall include, at a minimum, the information required under permit condition 3.5.7. and the following information, as applicable:
 - i. Summary information on the number, duration and cause (including unknown cause, if applicable) of excursions or exceedances, as applicable, and the corrective actions taken;
 - ii. Summary information on the number, duration and cause (including unknown cause, if applicable) for monitoring downtime incidents (other than downtime associated with zero and span or other daily calibration checks, if applicable) provided in accordance with 40 C.F.R. Part 75; and
 - iii. A description of the actions taken to implement QIP if applicable during the reporting period as specified in 40 C.F.R. §64.8. Upon completion of a QIP, the permittee shall include in the next summary report documentation that the implementation of the plan has been completed and reduced the likelihood of similar levels of excursions or exceedances occurring.

[40 C.F.R. §64.9(a); 45CSR§30-5.1.c.]

14.6. Compliance Plan

14.6.1. Reserved.

Attachment A

Sample Record Keeping Format
 Union Carbide Corporation: Boiler 27
 R13-2141C; Plant ID.: 0390003

Hours of Operation and Natural Gas Usage^{(1),(2)}

Month/Year:

Month	Natural Gas Usage (SCF)		Hours of Operation	Hourly Natural Gas Consumption Rate ⁽⁴⁾ (SCF/hr)
	Current Month	Rolling Yearly Total ⁽³⁾		
January				
February				
March				
April				
May				
June				
July				
August				
September				
October				
November				
December				

- Note:**
- (1) The CERTIFICATION OF DATA ACCURACY statement appearing on the reverse side of this form must be completed upon the written request of the Director or his duly-authorized representative.
 - (2) This record shall be maintained onsite for a period of five (5) years from the date of certification. It shall be made available upon request to the Director or his (her) authorized representative.
 - (3) The rolling yearly total for natural gas usage is not to exceed 3.092×10^3 million cubic feet.
 - (4) Natural gas consumption is not to exceed 353,000 scfm/hr (divide monthly usage by hours of operation for that month).

Attachment B

45CSR21 Consent Order - Attachment A “Emission Limitations”

Process Area Description and Identification Number	Name of Process Equipment Vented to Control Device and Equipment Identification Number	Maximum Theoretical Emissions (MTE) of the Source (lbs/hr)	Emission Point Identification Number	Control Device Identification Number	Control Device Description	Efficiency of Control Device (Percent)	Maximum Allowable Hours of Operation (hrs/yr)	Maximum Allowable VOC Emissions (lbs/hr)	Maximum Allowable VOC Emissions (lbs/yr)
700-Oxide Adducts System	Reactor System Equipment	3,212.00	multiple point source	not applicable	extended reaction	94(98% for epoxides)	8,760	186.00	9,857
700-Oxide Adducts System	Product Treatment and Product Treatment Beds	39.00	E-709/710/711 (Induce E-720.721.722. from Original CO)	C-709/710/711	Vacuum jet condensers	85	8,760	6.00	33,814
700-Oxide Adducts System	Solvent column vent	22.00	E-717	not applicable	not applicable	0	8,760	22.00	1,300
700-Oxide Adducts System	Solvent Evaporator Vent	22.00	E-718	not applicable	not applicable	0	8,760	22.00	1,300
1000-Specialty Surfactants	SSHDR (Header to Scrubber) Includes but not limited to Alkox Reactor, Large Cap Reactor, Small Cap Reactor and Tank 8370	880.00	E-1081-3	C-8400/C-8110/C-8130	Scrubbers	90	8,760	88.00	19,760
1000-Specialty Surfactants	Tank 8352	15.00	T-8352	not applicable	not applicable	0	8,760	15.00	4,900
1000-Specialty Surfactants	Tank 8362	10.00	T-8362	not applicable	not applicable	0	8,760	10.00	included with above
1000-Specialty Surfactants	Loading Rack	15.00	L-1004	not applicable	not applicable	0	8,760	15.00	included with above

Attachment C

45CSR21 Consent Order - Attachment B “Excess Emissions Scenarios”

Union Carbide Corporation – South Charleston Facility
 Attachment B to Regulation 21 Consent Order
 Revised April 2009

ROUTINE/NORMAL OPERATING & MAINTENANCE SCENARIOS RESULTING IN EXCESS EMISSIONS

Process Area Description and Identification Number	Emission Point Identification Number	Description of Excess Emission Scenario SU - Start-up SD - Shutdown M - Maintenance (Describe Activity)	Description of Controls and Measures used to Minimize VOC Emissions (During each Scenario)	Duration of Excess Emission Scenario (Hours) approximate	Typical/ Maximum Number of Events per Year approximate /	Average/Peak VOC Emissions per Event (Pounds per Hour) approximate /
Oxide Adducts Plant (700)	E-717	SU - Excess startups due to malfunctions, etc.	Automation prevents startups without condenser fan in service	1 / 2	52 / 150	20 / 40



Carney, Jonathan W <jonathan.w.carney@wv.gov>

Pre-Draft Permit and Fact Sheet Comments

1 message

Fedczak, Jay (JP) <JPFedczak@dow.com>
To: "Carney, Jonathan W" <jonathan.w.carney@wv.gov>
Cc: "Marino, Ana (AG)" <AGMarino@dow.com>

Thu, Mar 14, 2024 at 4:25 PM

Jonathan,

Thank you for the opportunity to review. Please see pre-draft comments, attached, for your consideration.

Jay

Jay Fedczak, P.E.

EH&S Delivery Manager

Union Carbide Corporation

A Wholly Owned Subsidiary of The Dow Chemical Company

South Charleston, WV 25303

O: 304-747-1354, Email: JPFedczak@dow.com



From: Carney, Jonathan W <jonathan.w.carney@wv.gov>
Sent: Tuesday, March 5, 2024 8:36 AM
To: Fedczak, Jay (JP) <JPFedczak@dow.com>
Cc: Marino, Ana (AG) <AGMarino@dow.com>
Subject:

CAUTION: This email originated from outside of the organization. Do not click links or open attachments unless you recognize the sender and know the content is safe.

Company Name: Union Carbide Corporation

Facility Name: South Charleston Facility

Facility ID: 039-00003

Application ID: R30-03900003-2024

Hello Jay,

Attached is the draft fact sheet that you requested.

--

Jonathan Carney, P.E.

WV Department of Environmental Protection

Division of Air Quality

NSR/Title V Air Permitting

[601 57th St SE](#)

[Charleston, WV 25304](#)

(304) 926-0499 ext. 41247

Jonathan.W.Carney@wv.gov

2 attachments



DPFactSheet R30-03900003-2024 watermarked pre-draft.docx
142K



Pre-DPPermit R30-03900003-2024.doc
1863K

MON requirements to add to Title V permit.

The following applies to Triton (section 5) and Chemical Mixing (section 12)

§ 63.2450 What are my general requirements for complying with this subpart?

(a) **General.** You must comply with (a)(2) of this section.

(2) Beginning no later than the compliance dates specified in § 63.2445(g), § 63.2450(a)(1) no longer applies. Instead, you must be in compliance with the emission limits and work practice standards in Tables 1 through 7 to this subpart at all times (where applicable), and you must meet the requirements specified in §§ 63.2455 through 63.2490 (or the alternative means of compliance in § 63.2495, § 63.2500, or § 63.2505) (where applicable), except as specified in paragraphs (b) through (v) of § 63.2450. You must meet the notification, reporting, and recordkeeping requirements specified in §§ 63.2515, 63.2520, and 63.2525.

The following apply to Triton (section 5) only.

(t) **New safety device requirements.** Beginning no later than the compliance dates specified in § 63.2445(g), § 63.2450 (p) no longer applies. Instead, you must comply with the requirements specified in § 63.2480(e).

The following applies to Triton (section 5) and Chemical Mixing (section 12)

(u) **General duty.** Beginning no later than the compliance dates specified in § 63.2445(g), at all times, you must operate and maintain any affected source, including associated air pollution control equipment and monitoring equipment, in a manner consistent with safety and good air pollution control practices for minimizing emissions. The general duty to minimize emissions does not require you to make any further efforts to reduce emissions if levels required by the applicable standard have been achieved. Determination of whether a source is operating in compliance with operation and maintenance requirements will be based on information available to the Administrator which may include, but is not limited to, monitoring results, review of operation and maintenance procedures, review of operation and maintenance records, and inspection of the source.

The following apply to Triton (section 5) only.

§ 63.2480 What requirements must I meet for equipment leaks?

(b)(7) For each piece of equipment that is subject to Table 6 to this subpart and is also subject to periodic monitoring with EPA Method 21 of 40 CFR part 60, appendix A-7, and is added to an affected source after December 17, 2019, or replaces equipment at an affected source after December 17, 2019, you must initially monitor for leaks within 30 days after initial startup of the equipment. Equipment that is designated as unsafe- or difficult-to-monitor is not subject to this paragraph (b)(7).

(e) Beginning no later than the compliance dates specified in § 63.2445(g), except as specified in § 63.2480 (e)(4), you must comply with the requirements specified in paragraphs (e)(1) and (2) of this section for pressure relief devices, such as relief valves or rupture disks, in organic HAP gas or vapor service instead of the pressure relief device requirements of § 63.165 of subpart H. Except as

specified in §§ 63.2480(e)(4) and (5), you must also comply with the requirements specified in paragraphs (e)(3), (6), and (7) of this section for all pressure relief devices in organic HAP service.

(1) **Operating requirements.** Except during a pressure release, operate each pressure relief device in organic HAP gas or vapor service with an instrument reading of less than 500 ppm above background as measured by the method in § 63.180(c) of subpart H.

(2) **Pressure release requirements.** For pressure relief devices in organic HAP gas or vapor service, you must comply with the applicable requirements paragraphs (e)(2)(i) through (iii) of this section following a pressure release.

(i) If the pressure relief device does not consist of or include a rupture disk, conduct instrument monitoring, as specified in § 63.180(c) of subpart H no later than 5 calendar days after the pressure relief device returns to organic HAP gas or vapor service following a pressure release to verify that the pressure relief device is operating with an instrument reading of less than 500 ppm.

(ii) If the pressure relief device includes a rupture disk, either comply with the requirements in paragraph (e)(2)(i) of this section (and do not replace the rupture disk) or install a replacement disk as soon as practicable after a pressure release, but no later than 5 calendar days after the pressure release. You must conduct instrument monitoring, as specified in § 63.180(c) of subpart H, no later than 5 calendar days after the pressure relief device returns to organic HAP gas or vapor service following a pressure release to verify that the pressure relief device is operating with an instrument reading of less than 500 ppm.

(iii) If the pressure relief device consists only of a rupture disk, install a replacement disk as soon as practicable after a pressure release, but no later than 5 calendar days after the pressure release. You must not initiate startup of the equipment served by the rupture disk until the rupture disk is replaced. You must conduct instrument monitoring, as specified in § 63.180(c) of subpart H, no later than 5 calendar days after the pressure relief device returns to organic HAP gas or vapor service following a pressure release to verify that the pressure relief device is operating with an instrument reading of less than 500 ppm.

(3) **Pressure release management.** Except as specified in §§ 63.2480(e)(4) and (5), you must comply with the requirements specified in paragraphs (e)(3)(i) through (v) of this section for all pressure relief devices in organic HAP service.

(i) You must equip each affected pressure relief device with a device(s) or use a monitoring system that is capable of:

(A) Identifying the pressure release;

(B) Recording the time and duration of each pressure release; and

(C) Notifying operators immediately that a pressure release is occurring. The device or monitoring system must be either specific to the pressure relief device itself or must be associated with the process system or piping, sufficient to indicate a pressure release to the atmosphere. Examples of these types of devices and systems include, but are not limited to, a rupture disk indicator, magnetic sensor, motion detector on the pressure relief valve stem, flow monitor, or pressure monitor.

(ii) You must apply at least three redundant prevention measures to each affected pressure relief device and document these measures. Examples of prevention measures include:

(A) Flow, temperature, liquid level and pressure indicators with deadman switches, monitors, or automatic actuators. Independent, non-duplicative systems within this category count as separate redundant prevention measures.

(B) Documented routine inspection and maintenance programs and/or operator training (maintenance programs and operator training may count as only one redundant prevention measure).

(C) Inherently safer designs or safety instrumentation systems.

(D) Deluge systems.

(E) Staged relief system where the initial pressure relief device (with lower set release pressure) discharges to a flare or other closed vent system and control device.

(iii) If any affected pressure relief device releases to atmosphere as a result of a pressure release event, you must perform root cause analysis and corrective action analysis according to the requirement in paragraph (e)(6) of this section and implement corrective actions according to the requirements in paragraph (e)(7) of this section. You must also calculate the quantity of organic HAP released during each pressure release event and report this quantity as required in § 63.2520(e)(15). Calculations may be based on data from the pressure relief device monitoring alone or in combination with process parameter monitoring data and process knowledge.

(iv) You must determine the total number of release events that occurred during the calendar year for each affected pressure relief device separately. You must also determine the total number of release events for each pressure relief device for which the root cause analysis concluded that the root cause was a *force majeure* event, as defined in § 63.2550.

(v) Except for pressure relief devices described in §§ 63.2480(e)(4) and (5), the following release events from an affected pressure relief device are a deviation of the pressure release management work practice standards.

(A) Any release event for which the root cause of the event was determined to be operator error or poor maintenance.

(B) A second release event not including *force majeure* events from a single pressure relief device in a 3 calendar year period for the same root cause for the same equipment.

(C) A third release event not including *force majeure* events from a single pressure relief device in a 3 calendar year period for any reason.

(6) Root cause analysis and corrective action analysis. A root cause analysis and corrective action analysis must be completed as soon as possible, but no later than 45 days after a release event. Special circumstances affecting the number of root cause analyses and/or corrective action analyses are provided in paragraphs (e)(6)(i) through (iii) of this section.

(i) You may conduct a single root cause analysis and corrective action analysis for a single emergency event that causes two or more pressure relief devices installed on the same equipment to release.

(ii) You may conduct a single root cause analysis and corrective action analysis for a single emergency event that causes two or more pressure relief devices to release, regardless of the

equipment served, if the root cause is reasonably expected to be a *force majeure* event, as defined in § 63.2550.

(iii) Except as provided in paragraphs (e)(6)(i) and (ii) of this section, if more than one pressure relief device has a release during the same time period, an initial root cause analysis must be conducted separately for each pressure relief device that had a release. If the initial root cause analysis indicates that the release events have the same root cause(s), the initially separate root cause analyses may be recorded as a single root cause analysis and a single corrective action analysis may be conducted.

(7) Corrective action implementation. You must conduct a root cause analysis and corrective action analysis as specified in paragraphs (e)(3)(iii) and (e)(6) of this section, and you must implement the corrective action(s) identified in the corrective action analysis in accordance with the applicable requirements in paragraphs (e)(7)(i) through (iii) of this section.

(i) All corrective action(s) must be implemented within 45 days of the event for which the root cause and corrective action analyses were required or as soon thereafter as practicable. If you conclude that no corrective action should be implemented, you must record and explain the basis for that conclusion no later than 45 days following the event.

(ii) For corrective actions that cannot be fully implemented within 45 days following the event for which the root cause and corrective action analyses were required, you must develop an implementation schedule to complete the corrective action(s) as soon as practicable.

(iii) No later than 45 days following the event for which a root cause and corrective action analyses were required, you must record the corrective action(s) completed to date, and, for action(s) not already completed, a schedule for implementation, including proposed commencement and completion dates.

The following applies to Triton (section 5) and Chemical Mixing (section 12)

§ 63.2485 What requirements must I meet for wastewater streams within an MCPU?

(j) You must determine the annual average concentration and annual average flowrate for wastewater streams for each MCPU.

The following apply to Triton (section 5) only.

§ 63.2490 What requirements must I meet for heat exchange systems?

(a) You must comply with each requirement in Table 10 to this subpart that applies to your heat exchange systems, except as specified in §§ 63.2490 (b) through (d).

(d) You must monitor the cooling water for the presence of total strippable hydrocarbons that indicate a leak according to paragraph (d)(1) of this section, and if you detect a leak, then you must repair it according to paragraph (d)(2) of this section, unless repair is delayed according to paragraph (d)(4) of this section.

(1) You must perform monitoring to identify leaks of total strippable hydrocarbons from each heat exchange system subject to the requirements of this subpart according to the procedures in paragraphs (d)(1)(ii) through (v) of this section.

(ii) **Monitoring locations for once-through heat exchange systems.** For each once-through heat exchange system, you must collect and analyze a sample from the location(s) described in paragraph (d)(1)(ii)(A) of this section. You may also elect to collect and analyze an additional sample from the location(s) described in §63.2490(d)(1)(ii)(B).

(A) Selected heat exchanger exit line(s), so that each heat exchanger or group of heat exchangers within a heat exchange system is covered by the selected monitoring location(s). The selected monitoring location may be at a point where discharges from multiple heat exchange systems are combined provided that the combined cooling water flow rate at the monitoring location does not exceed 40,000 gallons per minute.

(iii) **Monitoring method.** If you comply with the total strippable hydrocarbon concentration leak action level as specified in paragraph (d)(1)(iv) of this section, you must comply with the requirements in paragraph (d)(1)(iii)(A) of this section.

(A) You must determine the total strippable hydrocarbon concentration (in parts per million by volume (ppmv) as methane) at each monitoring location using the “Air Stripping Method (Modified El Paso Method) for Determination of Volatile Organic Compound Emissions from Water Sources” (incorporated by reference—see § 63.14) using a flame ionization detector (FID) analyzer for on-site determination as described in Section 6.1 of the Modified El Paso Method.

(iv) **Monitoring frequency and leak action level.** For each heat exchange system, you must initially monitor monthly (starting in August 2023) for 6-months beginning upon startup and monitor quarterly thereafter using a leak action level defined as a total strippable hydrocarbon concentration (as methane) in the stripping gas of 6.2 ppmv. If a leak is detected as specified in paragraph (d)(1)(v) of this section, then you must monitor monthly until the leak has been repaired according to the requirements in paragraph (d)(2) of this section. Once the leak has been repaired according to the requirements in paragraph (d)(2) of this section, quarterly monitoring for the heat exchange system may resume.

(v) **Leak definition.** A leak is defined as described in paragraph (d)(1)(v)(B) of this section.

(B) For all other heat exchange systems, a leak is detected if a measurement value of the sample taken from a location specified in (d)(1)(ii)(A) of this section equals or exceeds the leak action level.

(2) If a leak is detected using the methods described in paragraph (d)(1) of this section, you must repair the leak to reduce the concentration or mass emissions rate to below the applicable leak action level as soon as practicable, but no later than 45 days after identifying the leak, except as specified in paragraph (d)(4) of this section. Repair must include re-monitoring at the monitoring location where the leak was identified according to the method specified in paragraph (d)(1)(iii) of this section to verify that the total strippable hydrocarbon concentration or total hydrocarbon mass emissions rate is below the applicable leak action level. Actions that can be taken to achieve repair include but are not limited to:

(i) Physical modifications to the leaking heat exchanger, such as welding the leak or replacing tube;

(ii) Blocking the leaking tube within the heat exchanger;

(iii) Changing the pressure so that water flows into the process fluid;

(iv) Replacing the heat exchanger or heat exchanger bundle; or

(v) Isolating, bypassing, or otherwise removing the leaking heat exchanger from service until it is otherwise repaired.

(4) You may delay repair when one of the conditions in paragraph (d)(4)(i) or (ii) of this section is met and the leak is less than the delay of repair action level specified in paragraph (d)(4)(iii) of this section. You must determine if a delay of repair is necessary as soon as practicable, but no later than 45 days after first identifying the leak.

(i) If the repair is technically infeasible without a shutdown and the total strippable hydrocarbon concentration or total hydrocarbon mass emissions rate is initially and remains less than the delay of repair action level for all monitoring periods during the delay of repair, then you may delay repair until the next scheduled shutdown of the heat exchange system. If, during subsequent monitoring, the delay of repair action level is exceeded, then you must repair the leak within 30 days of the monitoring event in which the leak was equal to or exceeded the delay of repair action level.

(ii) If the necessary equipment, parts, or personnel are not available and the total strippable hydrocarbon concentration or total hydrocarbon mass emissions rate is initially and remains less than the delay of repair action level for all monitoring periods during the delay of repair, then you may delay the repair for a maximum of 120 calendar days. You must demonstrate that the necessary equipment, parts, or personnel were not available. If, during subsequent monitoring, the delay of repair action level is exceeded, then you must repair the leak within 30 days of the monitoring event in which the leak was equal to or exceeded the delay of repair action level.

(iii) The delay of repair action level is a total strippable hydrocarbon concentration (as methane) in the stripping gas of 62 ppmv. The delay of repair action level is assessed as described in paragraph (d)(4)(iii)(B) of this section.

(B) For all other heat exchange systems, the delay of repair action level is exceeded if a measurement value of the sample taken from a location specified in (d)(1)(ii)(A) of this section equals or exceeds the delay of repair action level.

The following applies to Triton (section 5) and Chemical Mixing (section 12)

§ 63.2520 What reports must I submit and when?

(e) **Compliance report.** The compliance report must contain the information specified in paragraphs (e)(1) through (17) of § 63.2520. On and after August 12, 2023 or once the reporting template for this subpart has been available on the CEDRI website for 1 year, whichever date is later, you must submit all subsequent reports to the EPA via the CEDRI, which can be accessed through the EPA's CDX (<https://cdx.epa.gov>). The EPA will make all the information submitted through CEDRI available to the public without further notice to you. Do not use CEDRI to submit information you claim as CBI. Anything submitted using CEDRI cannot later be claimed to be CBI. You must use the appropriate electronic report template on the CEDRI website (<https://www.epa.gov/electronic-reporting-air-emissions/compliance-and-emissions-data-reporting-interface-cedri>) for this subpart. The date report templates become available will be listed on the CEDRI website. Unless the Administrator or delegated state agency or other authority has approved a different schedule for submission of reports under §§ 63.9(i) and 63.10(a) of subpart A, the report must be submitted by the deadline specified in this subpart, regardless of the method in which the report is submitted. Although we do not expect persons to assert a claim of CBI, if you wish to assert a CBI claim, submit a complete report, including information claimed to be CBI, to the EPA. The report must be generated using the appropriate form on the CEDRI website or an alternate electronic file consistent with the extensible markup language (XML) schema listed on the CEDRI website. Submit the

file on a compact disc, flash drive, or other commonly used electronic storage medium and clearly mark the medium as CBI. Mail the electronic medium to U.S. Environmental Protection Agency, Office of Air Quality Planning and Standards, Sector Policies and Programs Division, CORE CBI Office, U.S. EPA Mailroom (C404-02), Attention: Miscellaneous Organic Chemical Manufacturing Sector Lead, 4930 Old Page Rd., Durham, NC 27703. The same file with the CBI omitted must be submitted to the EPA via the EPA's CDX as described in this paragraph (e). All CBI claims must be asserted at the time of submission. Furthermore under CAA section 114(c) emissions data is not entitled to confidential treatment, and the EPA is required to make emissions data available to the public. Thus, emissions data will not be protected as CBI and will be made publicly available. You may assert a claim of EPA system outage or *force majeure* for failure to timely comply with the reporting requirement in this paragraph (e) provided you meet the requirements outlined in **§ 63.2520 (i)** or **(j)**, as applicable.

The following apply to Triton (section 5) only.

§ 63.2525 What records must I keep?

(l) Beginning no later than the compliance dates specified in § 63.2445(g), § 63.2525(h) no longer applies. Instead, for each deviation from a work practice standard, you must keep a record of the information specified in paragraph (l)(1) and (3) of this section. The records shall be maintained as specified in § 63.10(b)(1) of subpart A.

(1) In the event that an affected unit does not meet an applicable standard, record the number of deviations. For each deviation record the date, time, and duration of each deviation.

(3) Record actions taken to minimize emissions in accordance with § 63.2450(u) and any corrective actions taken to return the affected unit to its normal or usual manner of operation.

(q) For each pressure relief device subject to the pressure release management work practice standards in § 63.2480(e), you must keep the records specified in paragraphs (q)(1) through (3) of this section.

(1) Records of the prevention measures implemented as required in § 63.2480(e)(3)(ii).

(2) Records of the number of releases during each calendar year and the number of those releases for which the root cause was determined to be a *force majeure* event. Keep these records for the current calendar year and the past 5 calendar years.

(3) For each release to the atmosphere, you must keep the records specified in paragraphs (q)(3)(i) through (iv) of this section.

(i) The start and end time and date of each pressure release to the atmosphere.

(ii) Records of any data, assumptions, and calculations used to estimate of the mass quantity of each organic HAP released during the event.

(iii) Records of the root cause analysis and corrective action analysis conducted as required in § 63.2480(e)(3)(iii), including an identification of the affected facility, a statement noting whether the event resulted from the same root cause(s) identified in a previous analysis and either a description of the recommended corrective action(s) or an explanation of why corrective action is not necessary under § 63.2480(e)(7)(i).

(iv) For any corrective action analysis for which implementation of corrective actions are required in § 63.2480(e)(7), a description of the corrective action(s) completed within the first 45 days following the discharge and, for action(s) not already completed, a schedule for implementation, including proposed commencement and completion dates.

(r) For each heat exchange system, beginning no later than the compliance dates specified in § 63.2445(g), the recordkeeping requirements of § 63.104(f)(1) no longer apply; instead, you must keep records in paragraphs (r)(1) through (4) of this section.

(1) Monitoring data required by § 63.2490(d) that indicate a leak, the date the leak was detected, or, if applicable, the basis for determining there is no leak.

(2) The dates of efforts to repair leaks.

(3) The method or procedures used to confirm repair of a leak and the date the repair was confirmed.

(4) Documentation of delay of repair as specified in paragraphs (r)(4)(i) through (iv) of this section.

(i) The reason(s) for delaying repair.

(ii) A schedule for completing the repair as soon as practical.

(iii) The date and concentration or mass emissions rate of the leak as first identified and the results of all subsequent monitoring events during the delay of repair.

(iv) An estimate of the potential total hydrocarbon emissions from the leaking heat exchange system or heat exchanger for each required delay of repair monitoring interval following the procedures in paragraphs (r)(4)(iv)(A) through (C) of this section.

(A) If you comply with the total strippable hydrocarbon concentration leak action level, as specified in § 63.2490(d)(1)(iv), you must calculate the mass emissions rate by complying with the requirements of § 63.2490(d)(1)(iii)(B) or by determining the mass flow rate of the cooling water at the monitoring location where the leak was detected. Cooling water mass flow rates may be determined using direct measurement, pump curves, heat balance calculations, or other engineering methods. If you determine the mass flow rate of the cooling water, calculate the mass emissions rate by converting the stripping gas leak concentration (in ppmv as methane) to an equivalent liquid concentration, in parts per million by weight (ppmw), using equation 7-1 from "Air Stripping Method (Modified El Paso Method) for Determination of Volatile Organic Compound Emissions from Water Sources" (incorporated by reference—see § 63.14) and multiply the equivalent liquid concentration by the mass flow rate of the cooling water.

(B) For delay of repair monitoring intervals prior to repair of the leak, calculate the potential total hydrocarbon emissions for the leaking heat exchange system or heat exchanger for the monitoring interval by multiplying the mass emissions rate, determined in paragraph (r)(4)(iv)(A) of this section, by the duration of the delay of repair monitoring interval. The duration of the delay of repair monitoring interval is the time period starting at midnight on the day of the previous monitoring event or at midnight on the day the repair would have had to be completed if the repair had not been delayed, whichever is later, and ending at midnight of the day the of the current monitoring event.

(C) For delay of repair monitoring intervals ending with a repaired leak, calculate the potential total hydrocarbon emissions for the leaking heat exchange system or heat exchanger for the final delay of repair monitoring interval by multiplying the duration of the final delay of repair monitoring

interval by the mass emissions rate determined for the last monitoring event prior to the re-monitoring event used to verify the leak was repaired. The duration of the final delay of repair monitoring interval is the time period starting at midnight of the day of the last monitoring event prior to re-monitoring to verify the leak was repaired and ending at the time of the re-monitoring event that verified that the leak was repaired.



Carney, Jonathan W <jonathan.w.carney@wv.gov>

MON requirements to add to Title V permit

1 message

Fedczak, Jay (JP) <JPFedczak@dow.com>

Fri, Mar 8, 2024 at 11:50 AM

To: "Carney, Jonathan W" <jonathan.w.carney@wv.gov>

Jonathan,

Here is the new MON language to incorporate into R30-03900003-2024. I'm reviewing the Fact Sheet and Draft permit now but am not sure I will be able to finish by the end of March 11. I'll try my best.

Jay

Jay Fedczak, P.E.

EH&S Delivery Manager

Union Carbide Corporation

A Wholly Owned Subsidiary of The Dow Chemical Company

South Charleston, WV 25303

O: 304-747-1354, Email: JPFedczak@dow.com



General Business



MON requirements to add to Title V permit.docx

43K



Carney, Jonathan W <jonathan.w.carney@wv.gov>

(no subject)

1 message

Carney, Jonathan W <jonathan.w.carney@wv.gov>

Tue, Mar 5, 2024 at 8:36 AM

To: "Fedczak, Jay (JP)" <JPFedczak@dow.com>

Cc: AGMarino@dow.com

Company Name: Union Carbide Corporation

Facility Name: South Charleston Facility

Facility ID: 039-00003

Application ID: R30-03900003-2024

Hello Jay,

Attached is the draft fact sheet that you requested.

--

Jonathan Carney, P.E.

WV Department of Environmental Protection

Division of Air Quality

NSR/Title V Air Permitting

601 57th St SE

Charleston, WV 25304

(304) 926-0499 ext. 41247

Jonathan.W.Carney@wv.gov



DPFactSheet R30-03900003-2024 watermarked pre-draft.docx

117K



Carney, Jonathan W <jonathan.w.carney@wv.gov>

Pre-Draft Version of the Title V Permit for Union Carbide Corporation, South Charleston

1 message

Carney, Jonathan W <jonathan.w.carney@wv.gov>

Tue, Mar 5, 2024 at 8:04 AM

To: "Fedczak, Jay (JP)" <JPFedczak@dow.com>, AGMarino@dow.com

Company Name: Union Carbide Corporation

Facility Name: South Charleston Facility

Facility ID: 039-00003

Application ID: R30-03900003-2024

Hello Ana Marino,

Attached is the pre-draft Title V Permit Renewal for your review before it goes to notice. If you have any comments, please submit them to me by Monday March 11, 2024.

Sincerely,
Jonathan Carney

--

Jonathan Carney, P.E.
WV Department of Environmental Protection
Division of Air Quality
NSR/Title V Air Permitting
601 57th St SE
Charleston, WV 25304
(304) 926-0499 ext. 41247
Jonathan.W.Carney@wv.gov



DPPermit R30-03900003-2024.doc

1839K



Carney, Jonathan W <jonathan.w.carney@wv.gov>

Pre-Draft Version of the Title V Permit for UCC South Charleston

1 message

McCumbers, Carrie <carrie.mccumbers@wv.gov>

Mon, Mar 4, 2024 at 5:09 PM

To: "Supplee, Gwendolyn" <supplee.gwendolyn@epa.gov>

Cc: "Whapham, Joseph" <whapham.joseph@epa.gov>, Jonathan W Carney <jonathan.w.carney@wv.gov>

Hi Gwen,

Attached is the Pre-Draft version of the Title V Permit for Union Carbide Corporation, South Charleston, R30-03900003-2024. I have also attached a Pre-Draft version of the Fact Sheet. I would like for EPA to review these Pre-Draft documents and provide comments and suggestions prior to DAQ sending the Draft Title V Permit out for public comment.

Thanks,
Carrie

2 attachments



Pre-DRAFT Permit R30-03900003-2024 to EPA.doc
1837K



Pre-Draft FactSheet R30-03900003-2024 to EPA.docx
116K



Carney, Jonathan W <jonathan.w.carney@wv.gov>

Fwd: UCC SC CO

1 message

McCumbers, Carrie <carrie.mccumbers@wv.gov>

Tue, Jan 30, 2024 at 11:04 AM

To: Jonathan W Carney <jonathan.w.carney@wv.gov>

I think this is the last thing we were waiting on for UCC South Charleston.

----- Forwarded message -----

From: **Egnor, Michael** <michael.egnor@wv.gov>

Date: Tue, Jan 30, 2024 at 10:28 AM

Subject: UCC SC CO

To: Carrie McCumbers <carrie.mccumbers@wv.gov>, Jonathan W Carney <jonathan.w.carney@wv.gov>

The signed Union Carbide SC Consent Order is attached. There is no NSR update associated with this Consent Order.

Let me know if you have any questions.

Thanks,
Mike

 **CO-R27-2024-03 signed.pdf**
220K



Mink, Stephanie R <stephanie.r.mink@wv.gov>

Read: WV DAQ Title V Permit Application Status for Union Carbide Corporation; Institute Plant

1 message

Fedczak, Jay (JP) <JPFedczak@dow.com>
To: "stephanie.r.mink@wv.gov" <stephanie.r.mink@wv.gov>

Wed, Jun 1, 2022 at 2:52 PM

Your message

To: Fedczak, Jay (JP)
Subject: WV DAQ Title V Permit Application Status for Union Carbide Corporation; Institute Plant
Sent: Tuesday, November 30, 2021 9:33:38 AM (UTC-05:00) Eastern Time (US & Canada)

was read on Wednesday, June 1, 2022 2:52:32 PM (UTC-05:00) Eastern Time (US & Canada).



Mink, Stephanie R <stephanie.r.mink@wv.gov>

Automatic reply: WV DAQ Title V Permit Application Status for Union Carbide Corporation; South Charleston

1 message

Fedczak, Jay (JP) <JPFedczak@dow.com>
To: "Mink, Stephanie R" <stephanie.r.mink@wv.gov>

Mon, May 23, 2022 at 10:55 AM

I will be out of the office from 5/23 through 5/25. During this time, I will be checking email. For urgent requests, feel free to call and leave a message or text me at 304,546,0822.



Mink, Stephanie R <stephanie.r.mink@wv.gov>

WV DAQ Title V Permit Application Status for Union Carbide Corporation; South Charleston

4 messages

Mink, Stephanie R <stephanie.r.mink@wv.gov> Mon, May 23, 2022 at 10:54 AM
To: agmarino@dow.com, "Fedczak, Jay (JP)" <jpfedczak@dow.com>
Cc: Carrie McCumbers <carrie.mccumbers@wv.gov>, Jonathan W Carney <jonathan.w.carney@wv.gov>

RE: Application Status
Union Carbide Corporation
South Charleston Plant
Facility ID No. 039-00003
Application No. R30-03900003-2022

Dear Ms. Marino,

Your application for a Title V Permit Renewal for Union Carbide Corporation's South Charleston Plant was received by this Division on May 19, 2022, and was assigned to Jonathan Carney.

Should you have any questions, please contact the assigned permit writer, Jonathan Carney, at 304-926-0499, extension 41247, or Jonathan.W.Carney@wv.gov.

--

Stephanie Mink

Environmental Resources Associate
West Virginia Department of Environmental Protection
Division of Air Quality, Title V Permitting
601 57th Street SE
Charleston, WV 25304
Phone: 304-926-0499 x41281

Marino, Ana (AG) <AGMarino@dow.com> Mon, May 23, 2022 at 11:04 AM
To: "stephanie.r.mink@wv.gov" <stephanie.r.mink@wv.gov>

Your message

To: Marino, Ana (AG)

5/23/22, 1:35 PM

State of West Virginia Mail - WV DAQ Title V Permit Application Status for Union Carbide Corporation; South Charleston

Subject: WV DAQ Title V Permit Application Status for Union Carbide Corporation; South Charleston

Sent: Monday, May 23, 2022 9:54:44 AM (UTC-06:00) Central Time (US & Canada)

was read on Monday, May 23, 2022 10:04:41 AM (UTC-06:00) Central Time (US & Canada).

Carney, Jonathan W <jonathan.w.carney@wv.gov>
To: stephanie.r.mink@wv.gov

Mon, May 23, 2022 at 11:12 AM

Your message

To: Carney, Jonathan W

Subject: WV DAQ Title V Permit Application Status for Union Carbide Corporation; South Charleston

Sent: 5/23/22, 10:54:44 AM EDT

was read on 5/23/22, 11:12:19 AM EDT

McCumbers, Carrie <carrie.mccumbers@wv.gov>
To: stephanie.r.mink@wv.gov

Mon, May 23, 2022 at 12:32 PM

Your message

To: McCumbers, Carrie

Subject: WV DAQ Title V Permit Application Status for Union Carbide Corporation; South Charleston

Sent: 5/23/22, 10:54:44 AM EDT

was read on 5/23/22, 12:32:50 PM EDT



Mink, Stephanie R <stephanie.r.mink@wv.gov>

WV DAQ Title V Reminder Letter for Union Carbide Corporation; South Charleston Plant

4 messages

Mink, Stephanie R <stephanie.r.mink@wv.gov>
To: agmarino@dow.com, jpfedczak@dow.com
Cc: Carrie McCumbers <carrie.mccumbers@wv.gov>

Fri, Apr 1, 2022 at 2:07 PM

RE: Title V Permit Renewal Application**Union Carbide Corporation****South Charleston Plant****Permit No.: R30-03900003-2018****Plant ID No.: 039-00003**

Dear Ms. Marino:

On January 9, 2018, the WV Department of Environmental Protection Division of Air Quality issued a Title V permit to Union Carbide Corporation's South Charleston plant. Our records indicate that this Title V permit will expire on January 9, 2023, and a Title V permit renewal application is due for submittal on or before July 9, 2022.

In accordance with 45CSR§30-4.1.a.3, a permit renewal application is **timely** if it is submitted at least six (6) months prior to the date of permit expiration. Please bear in mind, the permit application must also be **complete** six (6) months prior to the permit expiration date. Refer to 45CSR§30-4.1.b for what constitutes a complete application. **Please note that as of March 16, 2020, the Division of Air Quality requests that all applications be submitted via email.** Instructions can be found at <https://dep.wv.gov/daq/permitting/Pages/TitleVGuidanceandForms.aspx>.

Please ensure the **timely** and **complete** submittal of the permit renewal application. An application shield will only be granted for an application which is **timely** and **complete**.

Should you have any questions, please contact me or Carrie McCumbers, Title V Program Manager, at 304-926-0499, ext. 41278.

--

Stephanie Mink

Environmental Resources Associate

West Virginia Department of Environmental Protection

Division of Air Quality, Title V Permitting

601 57th Street SE

Charleston, WV 25304

Phone: 304-926-0499 x41281

Fedczak, Jay (JP) <JPFedczak@dow.com>
To: "stephanie.r.mink@wv.gov" <stephanie.r.mink@wv.gov>

Sat, Apr 2, 2022 at 10:37 AM

Your message

To: Fedczak, Jay (JP)
Subject: WV DAQ Title V Reminder Letter for Union Carbide Corporation; South Charleston Plant

4/6/22, 3:15 PM

State of West Virginia Mail - WV DAQ Title V Reminder Letter for Union Carbide Corporation; South Charleston Plant

Sent: Friday, April 1, 2022 2:07:31 PM (UTC-05:00) Eastern Time (US & Canada)

was read on Saturday, April 2, 2022 10:37:07 AM (UTC-05:00) Eastern Time (US & Canada).

McCumbers, Carrie <carrie.mccumbers@wv.gov>
To: stephanie.r.mink@wv.gov

Mon, Apr 4, 2022 at 6:58 AM

Your message

To: McCumbers, Carrie
Subject: WV DAQ Title V Reminder Letter for Union Carbide Corporation; South Charleston Plant
Sent: 4/1/22, 2:07:31 PM EDT

was read on 4/4/22, 6:58:36 AM EDT

Marino, Ana (AG) <AGMarino@dow.com>
To: "stephanie.r.mink@wv.gov" <stephanie.r.mink@wv.gov>

Tue, Apr 5, 2022 at 10:05 AM

Your message

To: Marino, Ana (AG)
Subject: WV DAQ Title V Reminder Letter for Union Carbide Corporation; South Charleston Plant
Sent: Friday, April 1, 2022 1:07:31 PM (UTC-06:00) Central Time (US & Canada)

was read on Tuesday, April 5, 2022 9:04:24 AM (UTC-06:00) Central Time (US & Canada).

Division of Air Quality Permit Application Submittal

Please find attached a permit application for :

[Company Name; Facility Location]

- DAQ Facility ID (for existing facilities only):
- Current 45CSR13 and 45CSR30 (Title V) permits associated with this process (for existing facilities only):

- Type of NSR Application (check all that apply):

- Construction
- Modification
- Class I Administrative Update
- Class II Administrative Update
- Relocation
- Temporary
- Permit Determination

- Type of 45CSR30 (TITLE V) Application:

- Title V Initial
- Title V Renewal
- Administrative Amendment**
- Minor Modification**
- Significant Modification**
- Off Permit Change

****If the box above is checked, include the Title V revision information as ATTACHMENTS to the combined NSR/Title V application.**

- Payment Type:

- Credit Card (Instructions to pay by credit card will be sent in the Application Status email.)
- Check (Make checks payable to: WVDEP – Division of Air Quality)

Mail checks to:

WVDEP – DAQ – Permitting

Attn: NSR Permitting Secretary

601 57th Street, SE

Charleston, WV 25304

Please wait until DAQ emails you the Facility ID Number and Permit Application Number. Please add these identifiers to your check or cover letter with your check.

- If the permit writer has any questions, please contact (all that apply):

- Responsible Official/Authorized Representative

- Name:
- Email:
- Phone Number:

- Company Contact

- Name:
- Email:
- Phone Number:

- Consultant

- Name:
- Email:
- Phone Number:

Union Carbide Corporation South Charleston Facility
45CSR30 Permit Renewal Application
2022

TABLE OF CONTENTS

Description

Application
Attachment A - Area Map
Attachment B - Plot Plans
Attachment C - Process Flow Diagrams
Attachment D - Equipment Tables
Attachment E - Emission Unit Forms
Attachment G - Air Pollution Control Device Forms
Attachment I – New Applicable Requirements
Attachment K – Confidential Business Information (submitted under
separate cover letter)

10. Business Confidentiality Claims

Does this application include confidential information (per 45CSR31)? Yes No

If yes, identify each segment of information on each page that is submitted as confidential, and provide justification for each segment claimed confidential, including the criteria under 45CSR§31-4.1, and in accordance with the DAQ's "PRECAUTIONARY NOTICE-CLAIMS OF CONFIDENTIALITY" guidance.

11. Mailing Address

Street or P.O. Box: P.O. Box 8361

City: South Charleston

State: WV

Zip: 25303-

Telephone Number: (304) 747-2611

Fax Number: (304) 747-7158

12. Facility Location

Street: 437 MacCorkle Avenue SE

City: South Charleston

County: Kanawha

UTM Easting: 440.026 km

UTM Northing: 4,246.927 km

Zone: 17 or 18

Directions: From Charleston, travel I-64 west and take the Montrose exit. Turn right towards the river and proceed straight through the traffic light across MacCorkle Avenue directly to the South Charleston Facility.

Portable Source? Yes No

Is facility located within a nonattainment area? Yes No

If yes, for what air pollutants?

Is facility located within 50 miles of another state? Yes No

If yes, name the affected state(s).

Ohio
Kentucky

Is facility located within 100 km of a Class I Area¹? Yes No

If yes, name the area(s).

If no, do emissions impact a Class I Area¹? Yes No

¹ Class I areas include Dolly Sods and Otter Creek Wilderness Areas in West Virginia, and Shenandoah National Park and James River Face Wilderness Area in Virginia.

Union Carbide Corporation South Charleston Facility

13. Contact Information		
Responsible Official: Ana Marino		Title: WVO Responsible Care Leader
Street or P.O. Box: P. O. Box 8361		
City: South Charleston	State: WV	Zip: 25303-
Telephone Number: (304) 747-5084	Fax Number: (304) 747-3147	
E-mail address: AGMarino@dow.com		
Environmental Contact: Jay Fedczak		Title: EH&S Delivery Manager
Street or P.O. Box: P. O. Box 8361		
City: South Charleston	State: WV	Zip: 25303-
Telephone Number: (304) 747-1354	Fax Number: (304) 747-3147	
E-mail address: JPFedczak@dow.com		
Application Preparer: same as above		Title:
Company:		
Street or P.O. Box:		
City:	State:	Zip: -
Telephone Number: () -	Fax Number: () -	
E-mail address:		

Union Carbide Corporation South Charleston Facility

14. Facility Description

List all processes, products, NAICS and SIC codes for normal operation, in order of priority. Also list any process, products, NAICS and SIC codes associated with any alternative operating scenarios if different from those listed for normal operation.

Process	Products	NAICS	SIC
Chemical Mixing Plant	Miscellaneous organic chemicals (e.g. mixing and blending of organic chemical raw materials with other substances)	325199	2869
Energy Systems	Site Utilities – e.g. steam, water, plant air/nitrogen, etc.	Not Applicable	Not Applicable
Pipelines/Environmental Operations	Operations include plant water treatment plant and ethylene oxide distribution system.	Not Applicable	Not Applicable
Infrastructure Operations	Maintenance Operations and Bulk Shipping/Receiving of raw materials and products	Not Applicable	Not Applicable
Oxide Adducts Plant	Chemical intermediates for use in brake fluids, surfactants, hydraulic and metal working fluids	325199	2869
Remediation Operations	None - Soil/Groundwater Correction Action	Not Applicable	Not Applicable
TRITON® Plant	Miscellaneous surfactants	325199	2869

Provide a general description of operations.

The Union Carbide Corporation (UCC) South Charleston Facility is a manufacturing facility that produces different specialty chemicals and plastics and serves as a re-distribution facility for chemicals manufactured at other locations. Chemicals and plastics are produced from the derivatives of natural gas and petroleum. Most of these are intermediates are used in other processes or sold to customers who convert them into finished products.

Chemical Mixing Plant (Area Id. 050).

The Chemical Mixing Plant uses a variety of raw materials which can be categorized into large volume bulk fluids and small volume additives. The bulk fluids are received by tank car and tank truck. Additives are received in containers. The bulk fluids are transferred to blending tanks or raw material storage tanks. Four vessels can be used for the addition of additives to the bulk fluids to produce mixtures. The mixtures are then sampled and shipped to customers by tank car, tank trucks, or containers.

The Chemical Mixing Plant operations are limited to blending and filtering.

Energy Systems and Pipelines

Energy Systems provides and maintains utilities for site operations (Area Id. 021). Pipelines includes the ethylene oxide distribution system (Area Id. 731).

Infrastructure

Maintenance - The South Charleston Facility operates a Maintenance Department with associated facilities including a Maintenance Shop and a Maintenance Garage. (Area Id. 012). Activities include welding, parts cleaning, metal working, and painting (of small parts).

Typical activities in the shops and in the field include, but are not limited to, general repair, machine work, painting, welding, abrasive blasting, carpentry, mechanical, electrical, instrument repair and testing, insulation (including removal of asbestos containing materials), etc.

Logistics Group - operates the North Charleston Distribution Terminal (NCDT) (Area Id. 031). The terminal is designed to receive and distribute products and raw materials. This facility does not produce any products through chemical reactions. From time to time materials may be blended through an in-line blender while loading.

The distribution facility has the capabilities to receive and to ship or transfer products via tank-truck, railcar, barge, and pipeline. At this time, all equipment owned by UCC and located at NCDT is out of service.

Plant Laboratory - provides chemical analysis and analytical support to plant operations. (Area Id. 355).

Environmental Operations

Environmental Operations operates water plant (Area Id. 020) and the wastewater flume/sump system (Area Id. 022).

Oxide Adducts Plant

Oxide Adducts Plant produces a diverse mix of chemical intermediates for use in brake fluids, surfactants, hydraulic and metal working fluids. (Area Id. 700).

Union Carbide Corporation South Charleston Facility

The Oxide Adducts Plant is made up of several distinct batch activities. Polyether polyols are produced on a batch basis by reacting ethylene oxide and/or propylene oxide with alcohols. Various materials are used as catalysts and starter solutions which are made by separate process systems. Reactor products may be treated in a neutralization step. Process solvent is recovered and products sent to storage. Products are shipped in various types of containers.

Remediation Operations is responsible for soil/groundwater corrective actions at the site.

For the chlorobenzene/chlorohydrin area contaminants are extracted from the groundwater and soil through soil vapor extraction (SVE) wells using a vacuum blower. Volatile organic compounds (VOCs) and non-VOCs (i.e., methane) present in the process vapor stream are vented to a regenerative thermal oxidizer or RTO. Thermal oxidation destroys VOCs/non-VOCs through direct combustion at temperatures where organic compounds in the process vapor stream are thermodynamically unstable. The oxidation process results in the formation of carbon dioxide, water vapor, and inorganic acids. Oxidizer exhaust vent gas are quenched and routed to a wet scrubber for removal of hydrogen chloride prior to venting to the air. A dilute caustic (sodium hydroxide) solution is being used as the scrubber liquor to enhance hydrogen chloride removal effectiveness.

For the middle island source 2 a similar process is used to destroy contaminants, except an electric catalytic oxidizer is used and there is no scrubbing of the exhaust. This source is currently shut down.

For the middle island groundwater containment system, this source remediates groundwater contamination through a series of process operations and emissions are controlled by an electric catalytic oxidizer.

Specialty Surfactants Plant

Specialty Surfactants Plant (also known as TRITON® Plant) produces various chemical intermediates that are used in metal cleaners, emulsion polymerization, paints and coatings, rinse aids, textile processing, degreasers, industrial laundry applications, car wash applications and personal care applications. (Area Id. 1000)

TRITON® Products are manufactured in batch/semi-batch and continuous reaction systems. Ethoxylated and propoxylated intermediates and finished products are produced in a semi-batch reaction system. These materials may be further processed in other reaction systems to produce surfactant products. Tanks are used to store raw materials, intermediates, wastes and finished products. Other major equipment in the Plant includes surfactant recovery system and filtration equipment. Products are shipped via containers, tank trucks and rail cars.

Revisions to current permit

Revisions to the equipment table for the Environmental Operations, Remediation, and Triton unit are provided in Attachment D and should be translated to the emissions units table in section 1.1 of the current permit. Recent requested revisions via the minor modification process for which the revised Title V permit has not been issued are included as proposed/revised/new applicable requirements in Attachment I.

15. Provide an **Area Map** showing plant location as **ATTACHMENT A**.

16. Provide a **Plot Plan(s)**, e.g. scaled map(s) and/or sketch(es) showing the location of the property on which the stationary source(s) is located as **ATTACHMENT B**. For instructions, refer to "Plot Plan - Guidelines."

17. Provide a detailed **Process Flow Diagram(s)** showing each process or emissions unit as **ATTACHMENT C**. Process Flow Diagrams should show all emission units, control equipment, emission points, and their relationships.

Section 2: Applicable Requirements

18. Applicable Requirements Summary	
Instructions: Mark all applicable requirements.	
<input checked="" type="checkbox"/> SIP	<input type="checkbox"/> FIP
<input checked="" type="checkbox"/> Minor source NSR (45CSR13)	<input type="checkbox"/> PSD (45CSR14)
<input checked="" type="checkbox"/> NESHAP (45CSR34)	<input type="checkbox"/> Nonattainment NSR (45CSR19)
<input checked="" type="checkbox"/> Section 111 NSPS	<input checked="" type="checkbox"/> Section 112(d) MACT standards
<input type="checkbox"/> Section 112(g) Case-by-case MACT	<input checked="" type="checkbox"/> 112(r) RMP
<input type="checkbox"/> Section 112(i) Early reduction of HAP	<input type="checkbox"/> Consumer/commercial prod. reqts., section 183(e)
<input type="checkbox"/> Section 129 Standards/Reqts.	<input checked="" type="checkbox"/> Stratospheric ozone (Title VI)
<input type="checkbox"/> Tank vessel reqt., section 183(f)	<input type="checkbox"/> Emissions cap 45CSR§30-2.6.1
<input type="checkbox"/> NAAQS, increments or visibility (temp. sources)	<input checked="" type="checkbox"/> 45CSR27 State enforceable only rule
<input checked="" type="checkbox"/> 45CSR4 State enforceable only rule	<input type="checkbox"/> Acid Rain (Title IV, 45CSR33)
<input type="checkbox"/> Emissions Trading and Banking (45CSR28)	<input checked="" type="checkbox"/> Compliance Assurance Monitoring (40CFR64)
<input type="checkbox"/> CAIR NO _x Annual Trading Program (45CSR39)	<input checked="" type="checkbox"/> CAIR NO _x Ozone Season Trading Program (45CSR40)
<input type="checkbox"/> CAIR SO ₂ Trading Program (45CSR41)	

19. Non Applicability Determinations
<p>List all requirements which the source has determined not applicable and for which a permit shield is requested. The listing shall also include the rule citation and the reason why the shield applies.</p> <p>From Title V Permit Currently in Effect:</p> <p>45CSR7 - Sulfuric acid mist/vapours and Phosphoric Acid vapours Tanks used to store sulfuric acid or phosphoric acid from concentration limits. Per Section 10.6 of Regulation 7, sources with potential to emit less than 0.1 lbs/hr, 100 lbs/yr are exempt from the concentration limits of Section 4.2. The following tanks have been found to meet this criteria:</p> <p>Tank 9750 is used to store sulfuric acid at the Oxide Adducts Plant. Tank 8372 is used to store sulfuric acid at the Specialty Surfactants (TRITON®) Plant. Tank 8433 is used to store phosphoric acid at the Specialty Surfactants (TRITON®) Plant. Tank T01 is used to store sulfuric acid at the Water Treatment Plant.</p> <p>45CSR7 - The carpentry shops (B463) and welding shops (B307) are used for fabrication of materials to support site operations. These activities are incidental (support) operations to the South Charleston Facility and are not manufacturing processes. Carpentry and welding shop activities are not covered by 45CSR7.</p>

19. Non Applicability Determinations (Continued) - Attach additional pages as necessary.

List all requirements which the source has determined not applicable and for which a permit shield is requested. The listing shall also include the rule citation and the reason why the shield applies.

45CSR10 and 45CSR10A - Testing, Monitoring, Record Keeping, and Reporting Requirements under 45CSR10 are not applicable to Boilers 26 and 27 since they only combust natural gas. 45CSR§10-10.3
Boilers 26 and 27 are also exempt from the 2000 ppm SO₂ requirements of 45CSR§10-4 due to 45CSR§10-4.1.e having a potential of less than 500 lbs/yr SO₂ from any manufacturing processes venting to these boilers. Additionally, 45CSR§10-5 for combustion of refinery or process gases containing hydrogen sulfide in excess of 50 grains/100 ft³ due to process gas streams having no known potential for sulfur contamination.

40CFR60, Subpart Kb - The following tanks associated with the Oxide Adducts Plant are greater than or equal to 19,813 gallons but less than 39,890 gallons and were constructed or modified after July 23, 1984 and have a maximum true vapor pressure less than 2.2 psia: 9513

The following tanks associated with the Oxide Adducts Plant are greater than or equal to 39,890 gallons and were constructed or modified after July 23, 1984 and have a maximum true vapor pressure less than 0.51 psia: 9510, 9511, and 9512

All tanks over 19,813 gallon capacity located at the Specialty Surfactants (TRITON®) Plant store materials with < 2.2 psia vapor pressure at storage conditions.

40CFR63, Subpart Y - NESHAP for Marine Vessel Loading Operations.

The North Charleston Distribution Terminal is exempt from Subpart Y requirements because they no longer load barges at this location or any other location covered by this permit.

19. Non Applicability Determinations (Continued) - Attach additional pages as necessary.

List all requirements which the source has determined not applicable and for which a permit shield is requested. The listing shall also include the rule citation and the reason why the shield applies.

40CFR63, Subpart JJ - Wood Furniture Surface Coating. The South Charleston Facility is an incidental manufacturer and exempt from Subpart JJ. Less than 100 gallons per month surface coating and adhesive is used for wood furniture.

40CFR63, Subpart EEEE - The North Charleston Distribution Terminal (NCDT) and the Chemical Mixing Unit are exempt from the OLD MACT for one or more of the following reasons:

Storage vessels located at NCDT are part of processing units covered by other MACTs, or streams (materials transferred) have annual average true vapor pressure of Subpart EEEE Table 1 OHAPs at 77°F less than 0.1 psia, or streams contain less than 5% by weight of Subpart EEEE Table 1 OHAPS and are not organic liquids subject to the OLD MACT.

The EO distribution header system does not meet the definition of an OLD MACT affected source as defined in 40 C.F.R. 63.2338(b) and is therefore not covered by 40 C.F.R. 63, Subpart EEEE

The Specialty Surfactants (TRITON®) Plant is not subject to the OLD MACT. The Specialty Surfactants Plant is covered by the Polyether Polyol and Miscellaneous Organic Chemical Manufacturing MACT. Annual average vapor pressure of Table 1 OHAP at 77°F used as heat transfer liquid is less than 0.1 psia, or no streams containing greater than or equal to 5% by weight Table 1 OHAPS.

40CFR63, Subpart MMMM - Coating of Metal Parts. The South Charleston Facility is an incidental manufacturer and exempt from Subpart MMMM due to 40CFR§63.3881(b). This provision establishes a lower cut-off at less than 250 gallons per month of paints/solvents used.

40CFR63, Subpart FFFF - The TRITON® Plant has one reactor, which is subject to 40CFR63, Subpart PPP for polyethylene polyols production. As a result, reactor 8400 (Alkox Reactor) is exempt from the requirements of Subpart FFFF in accordance with §63.2435(b)(3).

20. Facility-Wide Applicable Requirements

List all facility-wide applicable requirements. For each applicable requirement, include the underlying rule/regulation citation and/or construction permit with the condition number. (Note: Title V permit condition numbers alone are not the underlying applicable requirements).

3.1. Limitations and Standards

- 3.1.1. **Open burning.** The open burning of refuse by any person is prohibited except as noted in 45CSR§6-3.1.
[45CSR§6-3.1.]
- 3.1.2. **Open burning exemptions.** The exemptions listed in 45CSR§6-3.1 are subject to the following stipulation: Upon notification by the Secretary, no person shall cause or allow any form of open burning during existing or predicted periods of atmospheric stagnation. Notification shall be made by such means as the Secretary may deem necessary and feasible.
[45CSR§6-3.2.]
- 3.1.3. **Asbestos.** The permittee is responsible for thoroughly inspecting the facility, or part of the facility, prior to commencement of demolition or renovation for the presence of asbestos and complying with 40 C.F.R. § 61.145, 40 C.F.R. § 61.148, and 40 C.F.R. § 61.150. The permittee, owner, or operator must notify the Secretary at least ten (10) working days prior to the commencement of any asbestos removal on the forms prescribed by the Secretary if the permittee is subject to the notification requirements of 40 C.F.R. § 61.145(b)(3)(i). The USEPA, the Division of Waste Management and the Bureau for Public Health - Environmental Health require a copy of this notice to be sent to them.
[40 C.F.R. §61.145(b) and 45CSR34]
- 3.1.4. **Odor.** No person shall cause, suffer, allow or permit the discharge of air pollutants which cause or contribute to an objectionable odor at any location occupied by the public.
[45CSR§4-3.1 State-Enforceable only.]
- 3.1.5. **Standby plan for reducing emissions.** When requested by the Secretary, the permittee shall prepare standby plans for reducing the emissions of air pollutants in accordance with the objectives set forth in Tables I, II, and III of 45CSR11.
[45CSR§11-5.2]
- 3.1.6. **Emission inventory.** The permittee is responsible for submitting, on an annual basis, an emission inventory in accordance with the submittal requirements of the Division of Air Quality.
[W.Va. Code § 22-5-4(a)(14)]
- 3.1.7. **Ozone-depleting substances.** For those facilities performing maintenance, service, repair or disposal of appliances, the permittee shall comply with the standards for recycling and emissions reduction pursuant to 40 C.F.R. Part 82, Subpart F, except as provided for Motor Vehicle Air Conditioners (MVACs) in Subpart B:
- a. Persons opening appliances for maintenance, service, repair, or disposal must comply with the prohibitions and required practices pursuant to 40 C.F.R. §§ 82.154 and 82.156.
 - b. Equipment used during the maintenance, service, repair, or disposal of appliances must comply with the standards for recycling and recovery equipment pursuant to 40 C.F.R. § 82.158.

- c. Persons performing maintenance, service, repair, or disposal of appliances must be certified by an approved technician certification program pursuant to 40 C.F.R. § 82.161.

[40 C.F.R. 82, Subpart F]

- 3.1.8. **Risk Management Plan.** This stationary source, as defined in 40 C.F.R. § 68.3, is subject to Part 68. This stationary source shall submit a risk management plan (RMP) by the date specified in 40 C.F.R. § 68.10. This stationary source shall certify compliance with the requirements of Part 68 as part of the annual compliance certification as required by 40 C.F.R. Part 70 or 71.

[40 C.F.R. 68]

- 3.1.9. Reserved.

- 3.1.10. **Ozone Season NOx Emission Limitation.** The owner or operator of a unit that has a maximum design heat input greater than 250 mmBtu/hr, except for any unit subject to the federal Cross-State Air Pollution Rule NOx Ozone Season Trading Program established under 40 CFR Part 97, Subpart BBBB, or an equivalent trading program established under regulations approved as a state implementation plan revision pursuant to 40 CFR §52.38(b)(5), shall comply with the ozone season NOx emission limitation, and monitoring, recordkeeping and reporting requirements for ozone season emissions of NOx set forth in 45CSR§40-5.1 and 45CSR§40-6.1. [45CSR§40-4.1]

- a. Beginning May 1, 2016, the owner or operator of a unit that meets the applicability requirements set forth in 45CSR§40-4.1 shall limit emissions of NOx during an ozone season pursuant to a NOx emission rate for each unit contained in a permit issued under 45CSR13, 45CSR14, 45CSR19 or via consent order issued by the Secretary in accordance with W.Va. Code §22-5-4(a)(5). Such ozone season NOx limitation may also include a limitation on operating time for a unit during the ozone season. [45CSR§40-5.1.]
- b. The owner or operator of an applicable unit under 45CSR§40-4.1 shall operate certified continuous emission monitor systems necessary to attribute ozone season NOx mass emissions to each unit, in accordance with 40 CFR Part 75, Subpart H. NOx mass emission measurements recorded and reported in accordance with 40 CFR Part 75, Subpart H shall be used to determine a unit's compliance with the ozone season NOx emission limitation set forth in 3.1.10.a. [45CSR§40-6.1.]

3.3. Testing Requirements

3.3.1. Stack testing. As per provisions set forth in this permit or as otherwise required by the Secretary, in accordance with the West Virginia Code, underlying regulations, permits and orders, the permittee shall conduct test(s) to determine compliance with the emission limitations set forth in this permit and/or established or set forth in underlying documents. The Secretary, or his duly authorized representative, may at his option witness or conduct such test(s). Should the Secretary exercise his option to conduct such test(s), the operator shall provide all necessary sampling connections and sampling ports to be located in such manner as the Secretary may require, power for test equipment and the required safety equipment, such as scaffolding, railings and ladders, to comply with generally accepted good safety practices. Such tests shall be conducted in accordance with the methods and procedures set forth in this permit or as otherwise approved or specified by the Secretary in accordance with the following:

- a. The Secretary may on a source-specific basis approve or specify additional testing or alternative testing to the test methods specified in the permit for demonstrating compliance with 40 C.F.R. Parts 60, 61, and 63, if applicable, in accordance with the Secretary's delegated authority and any established equivalency determination methods which are applicable.
- b. The Secretary may on a source-specific basis approve or specify additional testing or alternative testing to the test methods specified in the permit for demonstrating compliance with applicable requirements which do not involve federal delegation. In specifying or approving such alternative testing to the test methods, the Secretary, to the extent possible, shall utilize the same equivalency criteria as would be used in approving such changes under Section 3.3.1.a. of this permit.
- c. All periodic tests to determine mass emission limits from or air pollutant concentrations in discharge stacks and such other tests as specified in this permit shall be conducted in accordance with an approved test protocol. Unless previously approved, such protocols shall be submitted to the Secretary in writing at least thirty (30) days prior to any testing and shall contain the information set forth by the Secretary. In addition, the permittee shall notify the Secretary at least fifteen (15) days prior to any testing so the Secretary may have the opportunity to observe such tests. This notification shall include the actual date and time during which the test will be conducted and, if appropriate, verification that the tests will fully conform to a referenced protocol previously approved by the Secretary.
- d. The permittee shall submit a report of the results of the stack test within 60 days of completion of the test. The test report shall provide the information necessary to document the objectives of the test and to determine whether proper procedures were used to accomplish these objectives. The report shall include the following: the certification described in paragraph 3.5.1; a statement of compliance status, also signed by a responsible official; and, a summary of conditions which form the basis for the compliance status evaluation. The summary of conditions shall include the following:

1. The permit or rule evaluated, with the citation number and language.
2. The result of the test for each permit or rule condition.
3. A statement of compliance or non-compliance with each permit or rule condition.

[WV Code § 22-5-4(a)(14-15) and 45CSR13]

3.4. Recordkeeping Requirements

3.4.1. **Monitoring information.** The permittee shall keep records of monitoring information that include the following:

- a. The date, place as defined in this permit and time of sampling or measurements;
- b. The date(s) analyses were performed;
- c. The company or entity that performed the analyses;
- d. The analytical techniques or methods used;
- e. The results of the analyses; and
- f. The operating conditions existing at the time of sampling or measurement.

[45CSR§30-5.1.c.2.A., 45CSR13, Permit Number R13-2033, Condition 4.2.1; R13-2840, Condition 4.3.1; R13-2414, Condition 4.4.1; R13-3308, Condition 4.4.1]

3.4.2. **Retention of records.** The permittee shall retain records of all required monitoring data and support information for a period of at least five (5) years from the date of monitoring sample, measurement, report, application, or record creation date. Support information includes all calibration and maintenance records and all original strip-chart recordings for continuous monitoring instrumentation, and copies of all reports required by the permit. Where appropriate, records may be maintained in computerized form in lieu of the above records.

[45CSR§30-5.1.c.2.B.]

3.4.3. **Odors.** For the purposes of 45CSR4, the permittee shall maintain a record of all odor complaints received, any investigation performed in response to such a complaint, and any responsive action(s) taken.

[45CSR§30-5.1.c. State-Enforceable only.]

3.5. Reporting Requirements

3.5.1. **Responsible official.** Any application form, report, or compliance certification required by this permit to be submitted to the DAQ and/or USEPA shall contain a certification by the responsible official that states that, based on information and belief formed after reasonable inquiry, the statements and information in the document are true, accurate and complete.
[45CSR§§30-4.4. and 5.1.c.3.D.]

3.5.2. A permittee may request confidential treatment for the submission of reporting required under 45CSR§30-5.1.c.3. pursuant to the limitations and procedures of W.Va. Code § 22-5-10 and 45CSR31.
[45CSR§30-5.1.c.3.E.]

3.5.3. Except for the electronic submittal of the annual compliance certification and semi-annual monitoring reports to the DAQ and USEPA as required in 3.5.5 and 3.5.6. below, all notices, requests, demands, submissions and other communications required or permitted to be made to the Secretary of DEP and/or USEPA shall be made in writing and shall be deemed to have been duly given when delivered by hand, mailed first class or by private carrier with postage prepaid to the address(es), or submitted in electronic format by e-mail as set forth below or to such other person or address as the Secretary of the Department of Environmental Protection may designate:

If to the DAQ:

Director
WVDEP
Division of Air Quality
601 57th Street SE
Charleston, WV 25304

If to the US EPA:

Associate Director
Office of Air Enforcement and Compliance
Assistance (3AP20)
U. S. Environmental Protection Agency
Region III
1650 Arch Street
Philadelphia, PA 19103-2029

DAQ Compliance and Enforcement¹:
DEPAirQualityReports@wv.gov

¹For all self-monitoring reports (MACT, GACT, NSPS, etc.), stack tests and protocols, Notice of Compliance Status reports, Initial Notifications, etc.

3.5.4. **Certified emissions statement.** The permittee shall submit a certified emissions statement and pay fees on an annual basis in accordance with the submittal requirements of the Division of Air Quality.
[45CSR§30-8.]

3.5.5. **Compliance certification.** The permittee shall certify compliance with the conditions of this permit on the forms provided by the DAQ. In addition to the annual compliance certification, the permittee may be required to submit certifications more frequently under an applicable requirement of this permit. The annual certification shall be submitted to the DAQ and USEPA on or before March 15 of each year, and shall certify compliance for the period ending December 31. The permittee shall maintain a copy of the certification on site for five (5) years from submittal of the certification. The annual certification to the USEPA shall be submitted in electronic format only. The annual certification shall be submitted in electronic format by e-mail to the following addresses:

DAQ: DEPAirQualityReports@wv.gov US EPA: R3_APD_Permits@epa.gov

[45CSR§30-5.3.e.]

3.5.6. **Semi-annual monitoring reports.** The permittee shall submit reports of any required monitoring on or before September 15 for the reporting period January 1 to June 30 and on or before March 15 for the reporting period July 1 to December 31. All instances of deviation from permit requirements must be clearly identified in such reports. All required reports must be certified by a responsible official consistent with 45CSR§30-4.4. The semi-annual monitoring reports shall be submitted in electronic format by e-mail to the following address:

DAQ:
DEPAirQualityReports@wv.gov
[45CSR§30-5.1.c.3.A.]

3.5.7. **Emergencies.** For reporting emergency situations, refer to Section 2.17 of this permit.

3.5.8. **Deviations.**

- a. In addition to monitoring reports required by this permit, the permittee shall promptly submit supplemental reports and notices in accordance with the following:
1. Any deviation resulting from an emergency or upset condition, as defined in 45CSR§30-5.7., shall be reported by telephone or telefax within one (1) working day of the date on which the permittee becomes aware of the deviation, if the permittee desires to assert the affirmative defense in accordance with 45CSR§30-5.7. A written report of such deviation, which shall include the probable cause of such deviations, and any corrective actions or preventative measures taken, shall be submitted and certified by a responsible official within ten (10) days of the deviation.
 2. Any deviation that poses an imminent and substantial danger to public health, safety, or the environment shall be reported to the Secretary immediately by telephone or telefax. A written report of such deviation, which shall include the probable cause of such deviation, and any corrective actions or preventative measures taken, shall be submitted by the responsible official within ten (10) days of the deviation.
 3. Deviations for which more frequent reporting is required under this permit shall be reported on the more frequent basis.
 4. All reports of deviations shall identify the probable cause of the deviation and any corrective actions or preventative measures taken.
[45CSR§30-5.1.c.3.C.]
- b. The permittee shall, in the reporting of deviations from permit requirements, including those attributable to upset conditions as defined in this permit, report the probable cause of such deviations and any corrective actions or preventive measures taken in accordance with any rules of the Secretary.
[45CSR§30-5.1.c.3.B.]

3.5.9. **New applicable requirements.** If any applicable requirement is promulgated during the term of this permit, the permittee will meet such requirements on a timely basis, or in accordance with a more detailed schedule if required by the applicable requirement.
[45CSR§30-4.3.h.1.B.]

Permit Shield

For all facility-wide applicable requirements listed above, provide monitoring/testing / recordkeeping / reporting which shall be used to demonstrate compliance. If the method is based on a permit or rule, include the condition number and/or citation. (Note: Each requirement listed above must have an associated method of demonstrating compliance. If there is not already a required method in place, then a method must be proposed.)

3.1.1 and 3.1.2. – Open burning, except for training of employees and safety personnel, is not conducted.

3.1.3. – Asbestos – Applicable records for renovation and demolition activities involving asbestos containing material will be maintained. Reports and notifications will be filed.

3.1.4. – Odor - For the purposes of 45CSR4, a record of all odor complaints received shall be maintained. Such record shall contain an assessment of the validity of the complaints as well as any corrective actions taken.

3.1.5. – Standby plan for reducing emissions – A plan will be prepared if requested by the Director.

3.1.6. – Emission Inventory – Emissions inventory information is provided in accordance with Rule 29 or as otherwise requested by the Director.

3.1.7. – Ozone depleting substances – Records will be maintained in accordance with 40 CFR 82, Subpart F.

3.1.8. – Risk Management Plan – information updated and on file in accordance with applicable requirements. The following Plants and Operations are covered by RMP: TRITON®, Oxide Adducts, Chemical Mixing, and EO Distribution.

Are you in compliance with all facility-wide applicable requirements? Yes No

If no, complete the **Schedule of Compliance Form** as ATTACHMENT F.

Union Carbide Corporation South Charleston Facility

21. Active Permits/Consent Orders		
Permit or Consent Order Number	Date of Issuance MM/DD/YYYY	List any Permit Determinations that Affect the Permit (<i>if any</i>)
R13-1517D (TRITON® Plant)	05/18/2015	
R13-2033D (Boiler 26)	04/03/2013	
R13-2141C (Boiler 27)	04/19/2004	
R13-2414C (Portable Air Compressors)	08/08/2011	
R13-2840E (Groundwater/Soil Remediation Process)	05/20/2016	
R13-3025B (Middle Island Remediation)	05/26/2015	
R13-3308B (MIGCS)	01/02/2019	
CO-R21-98-22, as amended (VOCs)	06/01/1998	
CO-R27-97-17-A(94-21) (TAPs)	04/25/1997	
CO-R40-C-2006-29 (CAIR)	10/03/2006	
	/ /	

Section 3: Facility-Wide Emissions

23. Facility-Wide Emissions Summary [Tons per Year]	
Criteria Pollutants	Potential Emissions (2021 Actual)
Carbon Monoxide (CO)	196 (51.16)
Nitrogen Oxides (NO _x)	434 (71.50)
Lead (Pb)	0 (0)
Particulate Matter (PM _{2.5}) ¹	30 (included with TSP)
Particulate Matter (PM ₁₀) ¹	30 (included with TSP)
Total Particulate Matter (TSP)	30 (5.36)
Sulfur Dioxide (SO ₂)	2 (0.53)
Volatile Organic Compounds (VOC)	228 (65.51)
Hazardous Air Pollutants ²	Potential Emissions
Benzyl Chloride	3.4 (0.95)
Hexane	5.73 (1.48)
Hydrogen Fluoride	0.5 (0)
Hydrogen Chloride	3.4 (0)
Glycol Ethers	8 (1.08)
Propylene Oxide	7 (1.73)
All Other HAPs (< 1 tpy individual emissions)	16.16 (1.98)
Regulated Pollutants other than Criteria and HAP	Potential Emissions

¹ PM_{2.5} and PM₁₀ are components of TSP.

² For HAPs that are also considered PM or VOCs, emissions should be included in both the HAPs section and the Criteria Pollutants section.

Section 4: Insignificant Activities

24. Insignificant Activities (Check all that apply)	
<input checked="" type="checkbox"/>	1. Air compressors and pneumatically operated equipment, including hand tools.
<input type="checkbox"/>	2. Air contaminant detectors or recorders, combustion controllers or shutoffs.
<input checked="" type="checkbox"/>	3. Any consumer product used in the same manner as in normal consumer use, provided the use results in a duration and frequency of exposure which are not greater than those experienced by consumer, and which may include, but not be limited to, personal use items; janitorial cleaning supplies, office supplies and supplies to maintain copying equipment.
<input checked="" type="checkbox"/>	4. Bathroom/toilet vent emissions.
<input type="checkbox"/>	5. Batteries and battery charging stations, except at battery manufacturing plants.
<input checked="" type="checkbox"/>	6. Bench-scale laboratory equipment used for physical or chemical analysis, but not lab fume hoods or vents. Many lab fume hoods or vents might qualify for treatment as insignificant (depending on the applicable SIP) or be grouped together for purposes of description.
<input type="checkbox"/>	7. Blacksmith forges.
<input checked="" type="checkbox"/>	8. Boiler water treatment operations, not including cooling towers.
<input checked="" type="checkbox"/>	9. Brazing, soldering or welding equipment used as an auxiliary to the principal equipment at the source.
<input type="checkbox"/>	10. CO ₂ lasers, used only on metals and other materials which do not emit HAP in the process.
<input checked="" type="checkbox"/>	11. Combustion emissions from propulsion of mobile sources, except for vessel emissions from Outer Continental Shelf sources.
<input checked="" type="checkbox"/>	12. Combustion units designed and used exclusively for comfort heating that use liquid petroleum gas or natural gas as fuel.
<input checked="" type="checkbox"/>	13. Comfort air conditioning or ventilation systems not used to remove air contaminants generated by or released from specific units of equipment.
<input checked="" type="checkbox"/>	14. Demineralized water tanks and demineralizer vents.
<input type="checkbox"/>	15. Drop hammers or hydraulic presses for forging or metalworking.
<input type="checkbox"/>	16. Electric or steam-heated drying ovens and autoclaves, but not the emissions from the articles or substances being processed in the ovens or autoclaves or the boilers delivering the steam.
<input type="checkbox"/>	17. Emergency (backup) electrical generators at residential locations.
<input type="checkbox"/>	18. Emergency road flares.
<input checked="" type="checkbox"/>	19. Emission units which do not have any applicable requirements and which emit criteria pollutants (CO, NO _x , SO ₂ , VOC and PM) into the atmosphere at a rate of less than 1 pound per hour and less than 10,000 pounds per year aggregate total for each criteria pollutant from all emission units. Please specify all emission units for which this exemption applies along with the quantity of criteria pollutants emitted on an hourly and annual basis: _____ _____ _____ _____ _____ _____ _____ _____

Union Carbide Corporation South Charleston Facility

24. Insignificant Activities (Check all that apply)	
<input checked="" type="checkbox"/>	<p>20. Emission units which do not have any applicable requirements and which emit hazardous air pollutants into the atmosphere at a rate of less than 0.1 pounds per hour and less than 1,000 pounds per year aggregate total for all HAPs from all emission sources. This limitation cannot be used for any source which emits dioxin/furans nor for toxic air pollutants as per 45CSR27.</p> <p>Please specify all emission units for which this exemption applies along with the quantity of hazardous air pollutants emitted on an hourly and annual basis:</p> <p>_____</p> <p>_____</p> <p>_____</p> <p>_____</p> <p>_____</p>
<input type="checkbox"/>	21. Environmental chambers not using hazardous air pollutant (HAP) gases.
<input type="checkbox"/>	22. Equipment on the premises of industrial and manufacturing operations used solely for the purpose of preparing food for human consumption.
<input type="checkbox"/>	23. Equipment used exclusively to slaughter animals, but not including other equipment at slaughterhouses, such as rendering cookers, boilers, heating plants, incinerators, and electrical power generating equipment.
<input checked="" type="checkbox"/>	24. Equipment used for quality control/assurance or inspection purposes, including sampling equipment used to withdraw materials for analysis.
<input checked="" type="checkbox"/>	25. Equipment used for surface coating, painting, dipping or spray operations, except those that will emit VOC or HAP.
<input checked="" type="checkbox"/>	26. Fire suppression systems.
<input checked="" type="checkbox"/>	27. Firefighting equipment and the equipment used to train firefighters.
<input type="checkbox"/>	28. Flares used solely to indicate danger to the public.
<input checked="" type="checkbox"/>	29. Fugitive emission related to movement of passenger vehicle provided the emissions are not counted for applicability purposes and any required fugitive dust control plan or its equivalent is submitted.
<input type="checkbox"/>	30. Hand-held applicator equipment for hot melt adhesives with no VOC in the adhesive formulation.
<input checked="" type="checkbox"/>	31. Hand-held equipment for buffing, polishing, cutting, drilling, sawing, grinding, turning or machining wood, metal or plastic.
<input type="checkbox"/>	32. Humidity chambers.
<input checked="" type="checkbox"/>	33. Hydraulic and hydrostatic testing equipment.
<input checked="" type="checkbox"/>	34. Indoor or outdoor kerosene heaters.
<input checked="" type="checkbox"/>	35. Internal combustion engines used for landscaping purposes.
<input type="checkbox"/>	36. Laser trimmers using dust collection to prevent fugitive emissions.
<input type="checkbox"/>	37. Laundry activities, except for dry-cleaning and steam boilers.
<input checked="" type="checkbox"/>	38. Natural gas pressure regulator vents, excluding venting at oil and gas production facilities.
<input type="checkbox"/>	39. Oxygen scavenging (de-aeration) of water.
<input type="checkbox"/>	40. Ozone generators.
<input checked="" type="checkbox"/>	41. Plant maintenance and upkeep activities (e.g., grounds-keeping, general repairs, cleaning, painting, welding, plumbing, re-tarring roofs, installing insulation, and paving parking lots) provided these activities are not conducted as part of a manufacturing process, are not related to the source's primary business activity, and not otherwise triggering a permit modification. (Cleaning and painting activities qualify if they are not subject to VOC or HAP control requirements. Asphalt batch plant

Union Carbide Corporation South Charleston Facility

24. Insignificant Activities (Check all that apply)	
	owners/operators must still get a permit if otherwise requested.)
<input checked="" type="checkbox"/>	42. Portable electrical generators that can be moved by hand from one location to another. "Moved by Hand" means that it can be moved without the assistance of any motorized or non-motorized vehicle, conveyance, or device.
<input checked="" type="checkbox"/>	43. Process water filtration systems and demineralizers.
<input checked="" type="checkbox"/>	44. Repair or maintenance shop activities not related to the source's primary business activity, not including emissions from surface coating or de-greasing (solvent metal cleaning) activities, and not otherwise triggering a permit modification.
<input checked="" type="checkbox"/>	45. Repairs or maintenance where no structural repairs are made and where no new air pollutant emitting facilities are installed or modified.
<input checked="" type="checkbox"/>	46. Routing calibration and maintenance of laboratory equipment or other analytical instruments.
<input type="checkbox"/>	47. Salt baths using nonvolatile salts that do not result in emissions of any regulated air pollutants. Shock chambers.
<input type="checkbox"/>	48. Shock chambers.
<input type="checkbox"/>	49. Solar simulators.
<input checked="" type="checkbox"/>	50. Space heaters operating by direct heat transfer.
<input checked="" type="checkbox"/>	51. Steam cleaning operations.
<input checked="" type="checkbox"/>	52. Steam leaks.
<input checked="" type="checkbox"/>	53. Steam sterilizers.
<input checked="" type="checkbox"/>	54. Steam vents and safety relief valves.
<input type="checkbox"/>	55. Storage tanks, reservoirs, and pumping and handling equipment of any size containing soaps, vegetable oil, grease, animal fat, and nonvolatile aqueous salt solutions, provided appropriate lids and covers are utilized.
<input checked="" type="checkbox"/>	56. Storage tanks, vessels, and containers holding or storing liquid substances that will not emit any VOC or HAP. Exemptions for storage tanks containing petroleum liquids or other volatile organic liquids should be based on size limits such as storage tank capacity and vapor pressure of liquids stored and are not appropriate for this list.
<input type="checkbox"/>	57. Such other sources or activities as the Director may determine.
<input type="checkbox"/>	58. Tobacco smoking rooms and areas.
<input checked="" type="checkbox"/>	59. Vents from continuous emissions monitors and other analyzers.

Section 5: Emission Units, Control Devices, and Emission Points

25. Equipment Table
Fill out the Title V Equipment Table and provide it as ATTACHMENT D .
26. Emission Units
For each emission unit listed in the Title V Equipment Table , fill out and provide an Emission Unit Form as ATTACHMENT E .
For each emission unit not in compliance with an applicable requirement, fill out a Schedule of Compliance Form as ATTACHMENT F .
27. Control Devices
For each control device listed in the Title V Equipment Table , fill out and provide an Air Pollution Control Device Form as ATTACHMENT G .
For any control device that is required on an emission unit in order to meet a standard or limitation for which the potential pre-control device emissions of an applicable regulated air pollutant is greater than or equal to the Title V Major Source Threshold Level, refer to the Compliance Assurance Monitoring (CAM) Form(s) for CAM applicability. Fill out and provide these forms, if applicable, for each Pollutant Specific Emission Unit (PSEU) as ATTACHMENT H .

Section 6: Certification of Information

28. Certification of Truth, Accuracy and Completeness and Certification of Compliance

Note: This Certification must be signed by a responsible official. The original, signed in blue ink, must be submitted with the application. Applications without an original signed certification will be considered as incomplete.

a. Certification of Truth, Accuracy and Completeness

I certify that I am a responsible official (as defined at 45CSR§30-2.38) and am accordingly authorized to make this submission on behalf of the owners or operators of the source described in this document and its attachments. I certify under penalty of law that I have personally examined and am familiar with the statements and information submitted in this document and all its attachments. Based on my inquiry of those individuals with primary responsibility for obtaining the information, I certify that the statements and information are to the best of my knowledge and belief true, accurate, and complete. I am aware that there are significant penalties for submitting false statements and information or omitting required statements and information, including the possibility of fine and/or imprisonment.

b. Compliance Certification

Except for requirements identified in the Title V Application for which compliance is not achieved, I, the undersigned hereby certify that, based on information and belief formed after reasonable inquiry, all air contaminant sources identified in this application are in compliance with all applicable requirements.

Responsible official (type or print)

Name: Ana Marino

Title: WVO Responsible Care Leader

Responsible official's signature:

Signature: Ana Marino Signature Date: 5-19-22
 (Must be signed and dated in blue ink)

Note: Please check all applicable attachments included with this permit application:

<input checked="" type="checkbox"/>	ATTACHMENT A: Area Map
<input checked="" type="checkbox"/>	ATTACHMENT B: Plot Plan(s)
<input checked="" type="checkbox"/>	ATTACHMENT C: Process Flow Diagram(s)
<input checked="" type="checkbox"/>	ATTACHMENT D: Equipment Table
<input checked="" type="checkbox"/>	ATTACHMENT E: Emission Unit Form(s)
<input type="checkbox"/>	ATTACHMENT F: Schedule of Compliance Form(s)
<input checked="" type="checkbox"/>	ATTACHMENT G: Air Pollution Control Device Form(s)
<input type="checkbox"/>	ATTACHMENT H: Compliance Assurance Monitoring (CAM) Form(s)

All of the required forms and additional information can be found and downloaded from, the DEP website at www.wydep.org/dag, requested by phone (304) 926-0475, and/or obtained through the mail.

Attachment A

Area Map

CHARLESTON

NORTH CHARLESTON

ORCHARD MANOR

VANDALLA

SOUTH CHARLESTON PLANT UNION CARBIDE CORPORATION

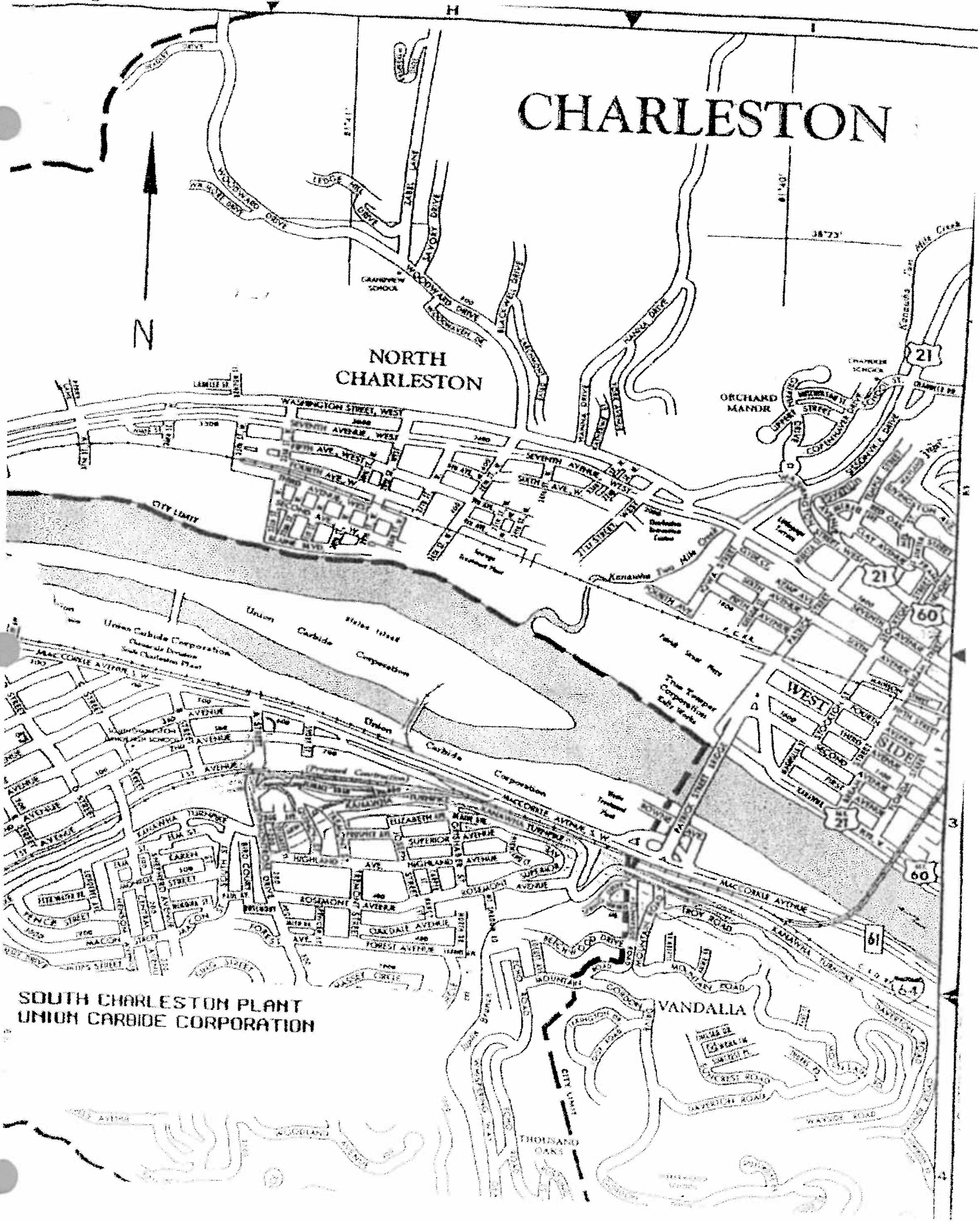

Attachment B

Plot Plans

CHEMICAL MIXING
ATTACHMENT B
PLOT PLAN

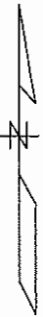

PLANT
NORTH

'2000' SERIES TANK FARM

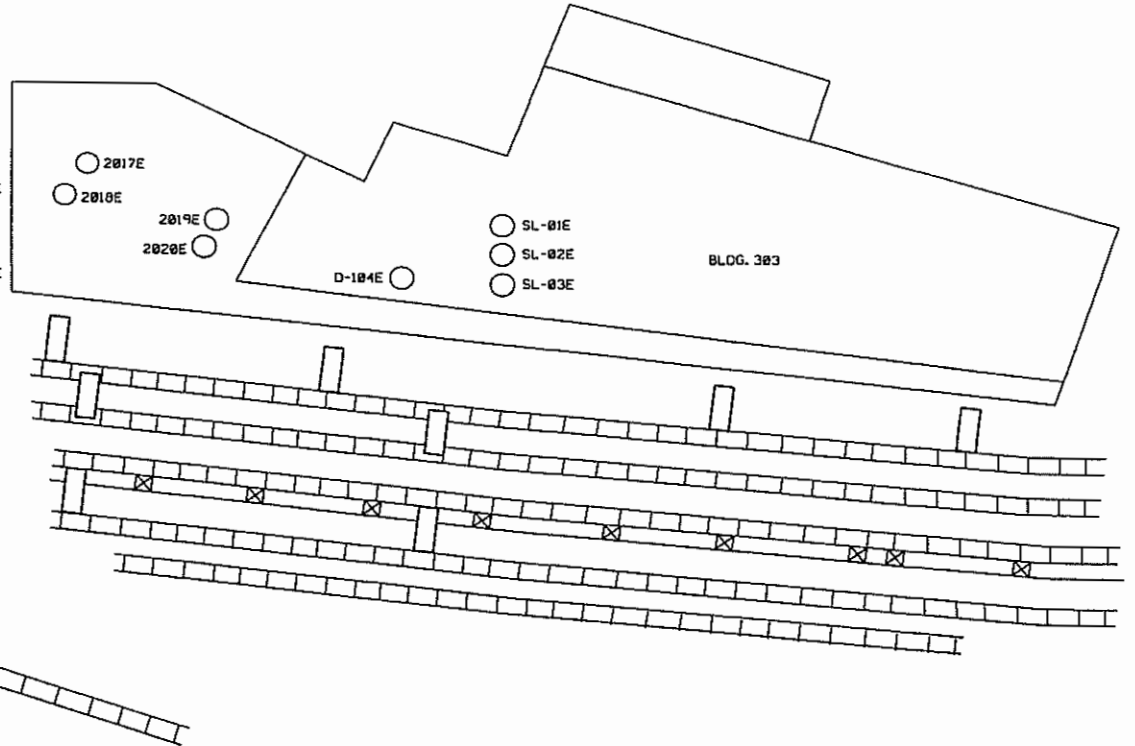
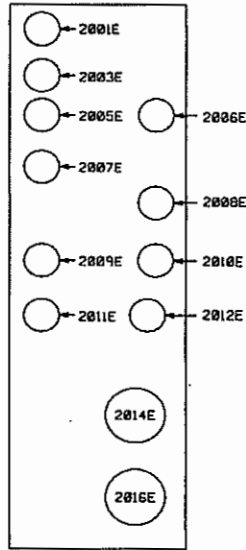
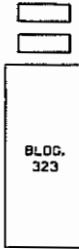
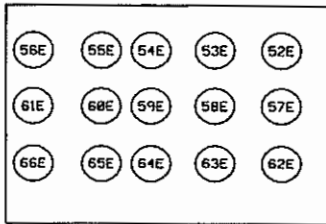
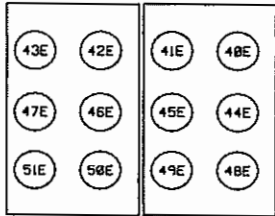

TRANSFER RACKS

(A) U.T.M. COORDINATES:
4,246,637 N; 440,238 E

TITLE V	
UNION CARBIDE SOUTH CHARLESTON FACILITY	
PROCESS AREA ID 050	CHEMICAL MIXING PLANT

ATTACHMENT B
PLOT PLAN

PIPELINES



Redated Copy
Claim of Confidentiality

TITLE V	
UNION CARBIDE SOUTH CHARLESTON FACILITY	
PROCESS AREA 10 731	EQ DISTRIBUTION HEADER

MAIN CHANNEL

ENERGY SYSTEMS
ATTACHMENT B
PLOT PLAN

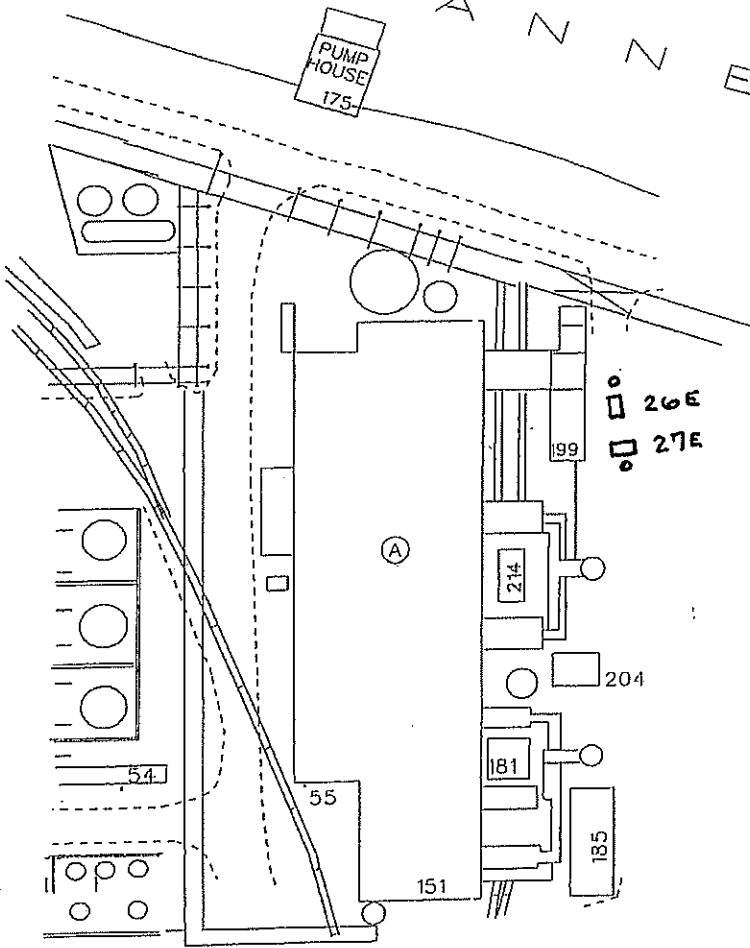

Ⓐ U.T.M. COORDINATES:
4,246,800 N; 440,630 E

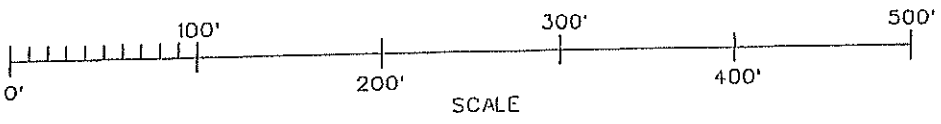

TITLE V	
UNION CARBIDE SOUTH CHARLESTON FACILITY.	
PROCESS AREA ID 021	ENERGY SYSTEMS

ENVIRONMENTAL OPERATIONS
ATTACHMENT B
PLOT PLAN

KANAWHA RIVER

BACK CHANNEL

FLOW

PUMP HOUSE
BL-73

DP01E
DP02E

BL-300

BL-308

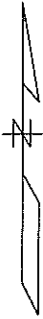

PLANT
NORTH

TITLE V

UNION CARBIDE
SOUTH CHARLESTON FACILITY

PROCESS AREA ID
014

ENVIROMENTAL
OPERATIONS
(B73)

ENVIRONMENTAL OPERATIONS
ATTACHMENT B
PLOT PLAN

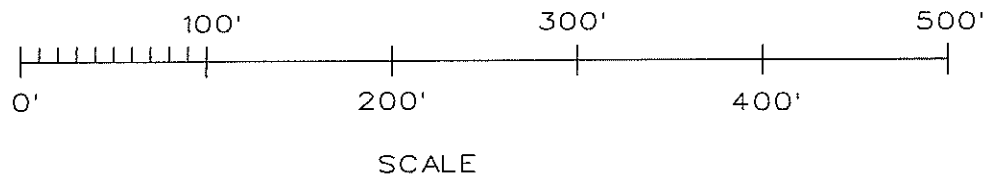
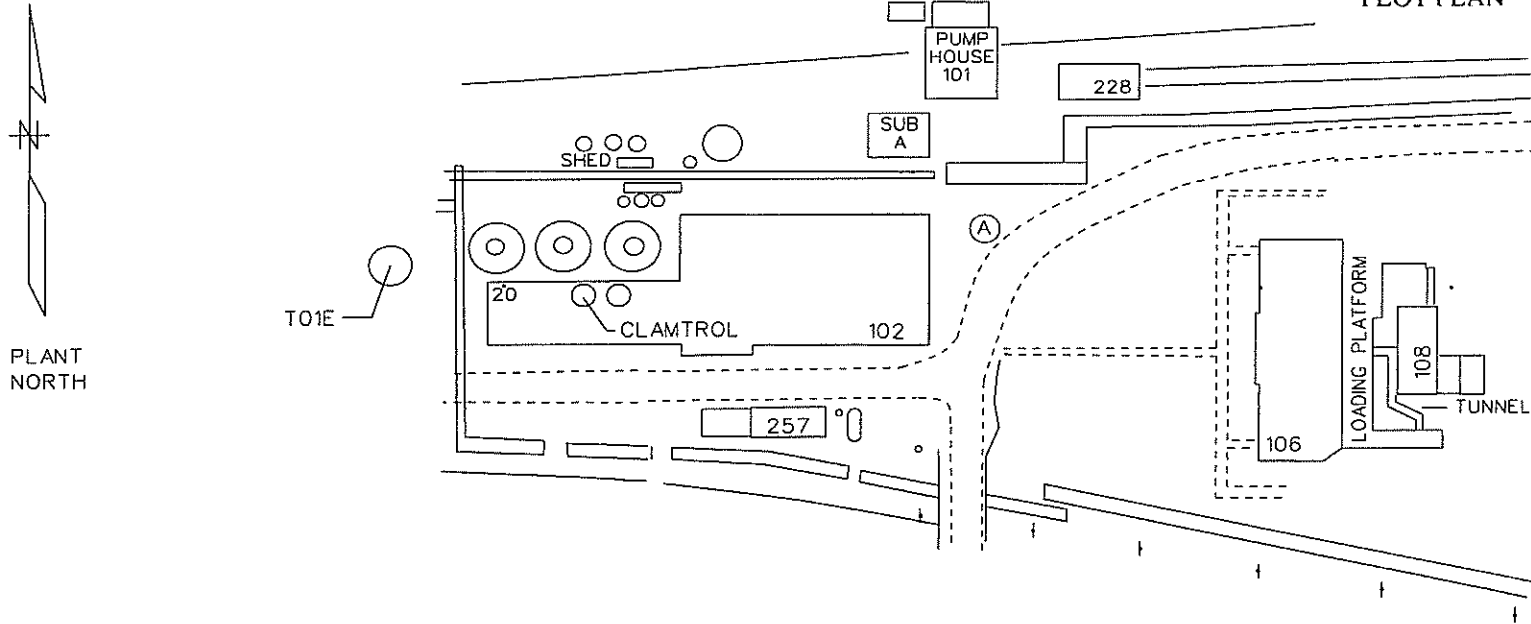

Ⓐ U.T.M. COORDINATES:
4,247,075 N; 439,765 E

TITLE V	
UNION CARBIDE SOUTH CHARLESTON FACILITY	
PROCESS AREA ID 020 & 355	WATER TREATMENT AND LABORATORY

INFRASTRUCTURE
ATTACHMENT B
PLOT PLAN



PLANT
NORTH

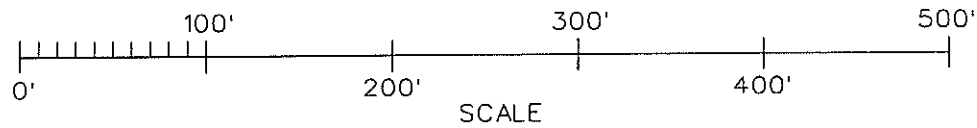
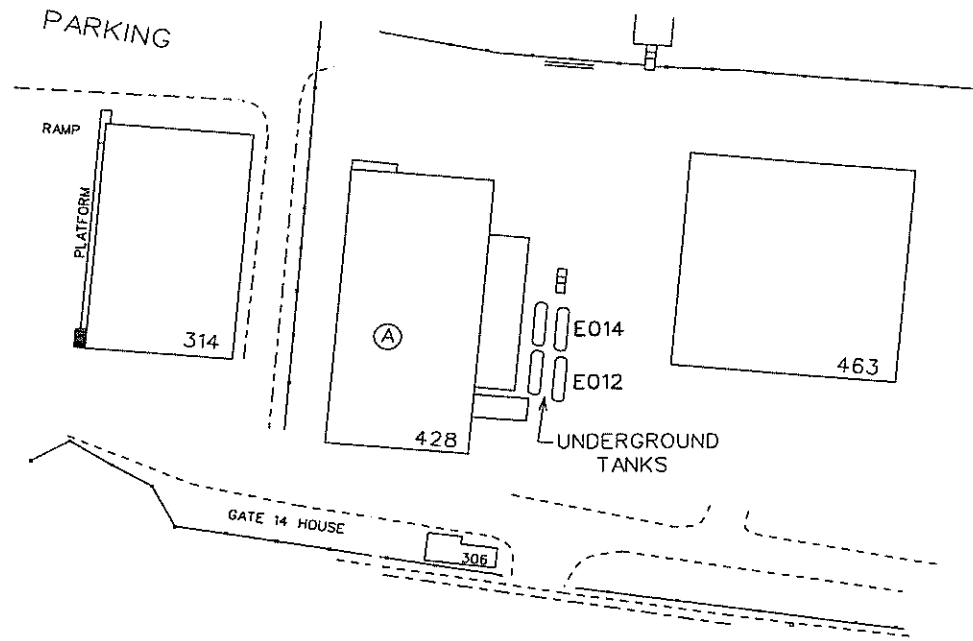

Ⓐ U.T.M. COORDINATES:
4,246,470 N; 440,570 E

TITLE V	
UNION CARBIDE SOUTH CHARLESTON FACILITY	
PROCESS AREA ID 012	MAINTENANCE (GARAGE)

INFRASTRUCTURE
ATTACHMENT B
PLOT PLAN



PLANT NORTH

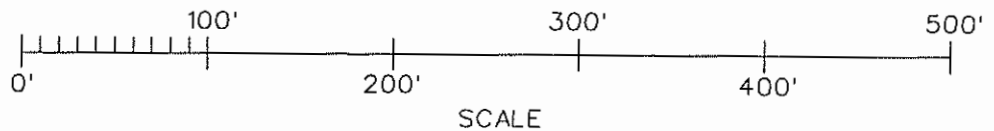
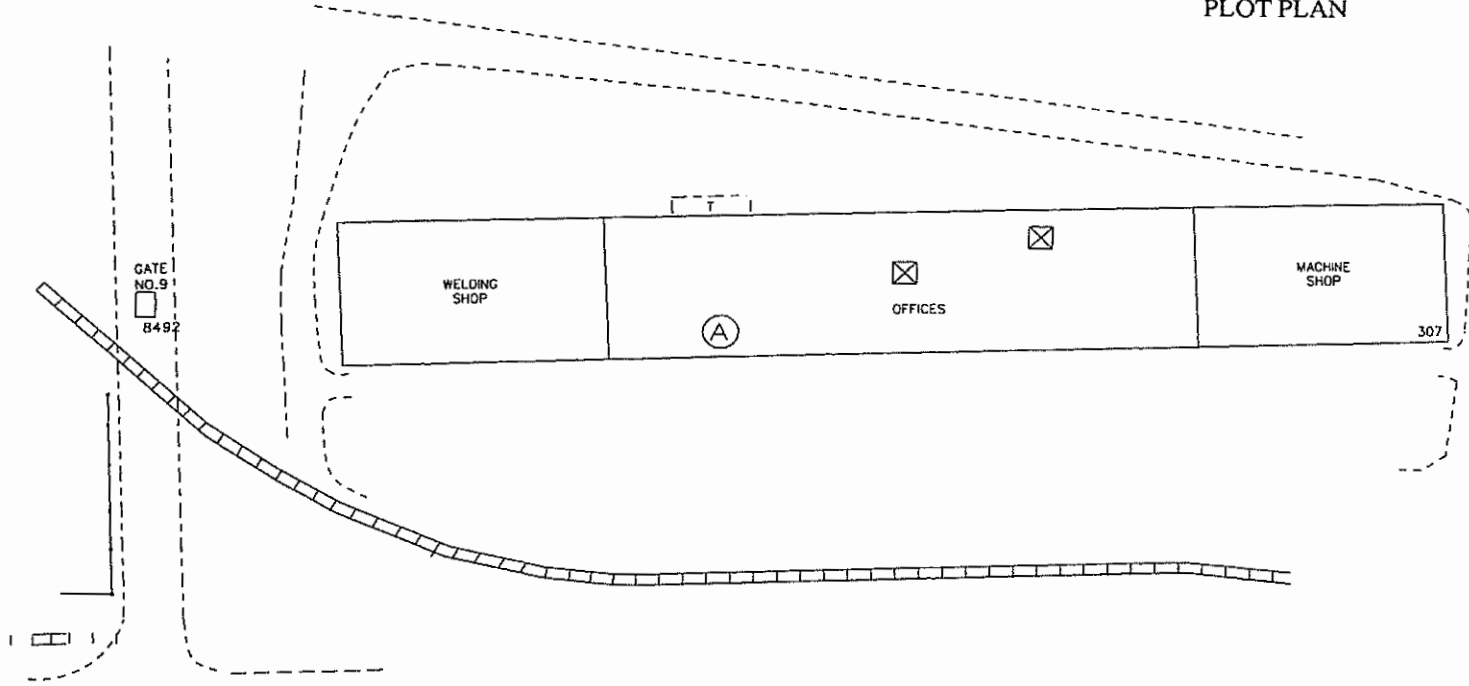

Ⓐ U.T.M. COORDINATES:
440,075 E; 4,246,675 N

⊗ METAL SOLVENT CLEANER

TITLE V	
UNION CARBIDE SOUTH CHARLESTON FACILITY	
PROCESS AREA ID 014	MAINTENANCE SHOPS (B307)

NORTH CHARLESTON
 DISTRIBUTION TERMINAL
 ATTACHMENT B
 PLOT PLAN

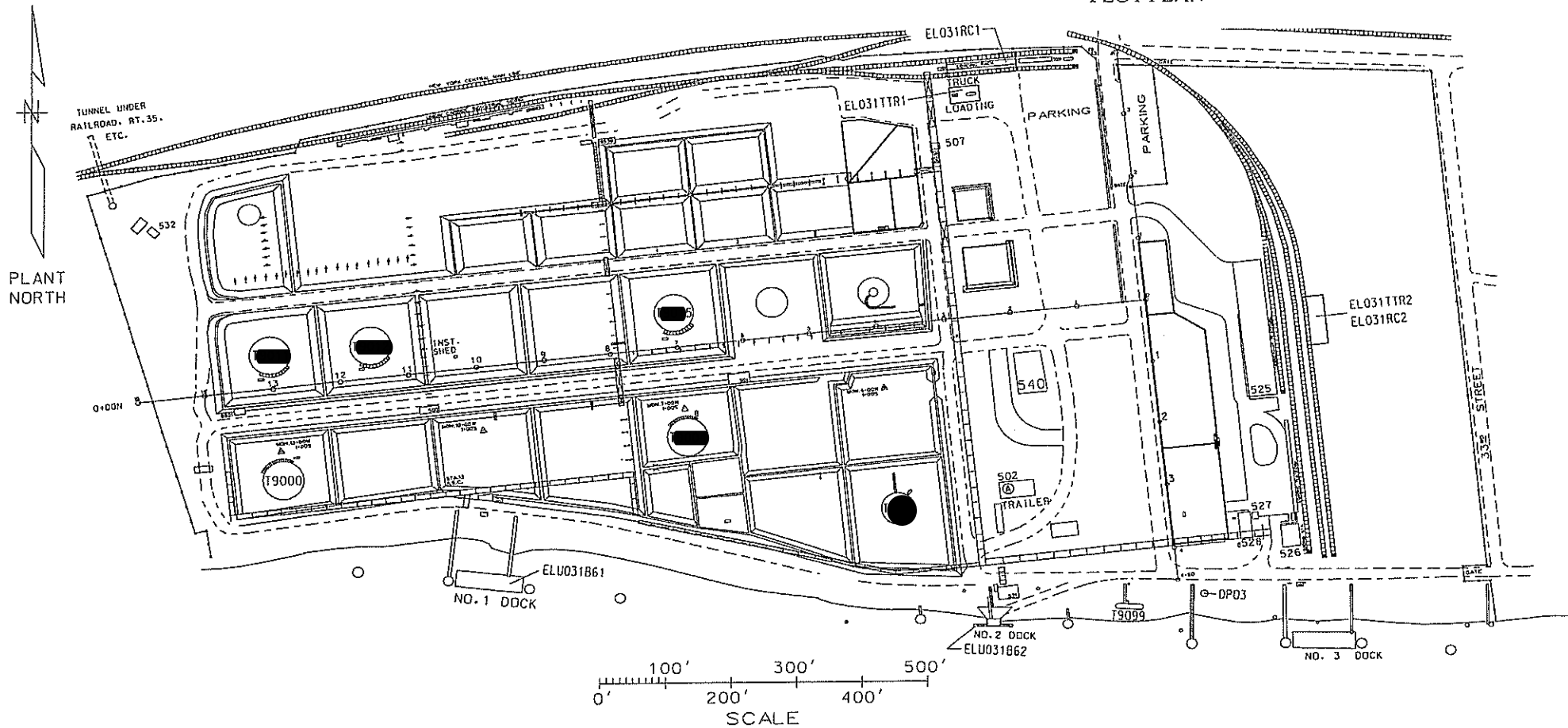

(A) U.T.M. COORDINATES:
4,247,330 N; 439,875 E

TITLE V	
UNION CARBIDE SOUTH CHARLESTON FACILITY	
PROCESS AREA ID 031	NORTH CHARLESTON DISTRIBUTION TERMINAL

OXIDE ADDUCTS
ATTACHMENT B
PLOT PLAN

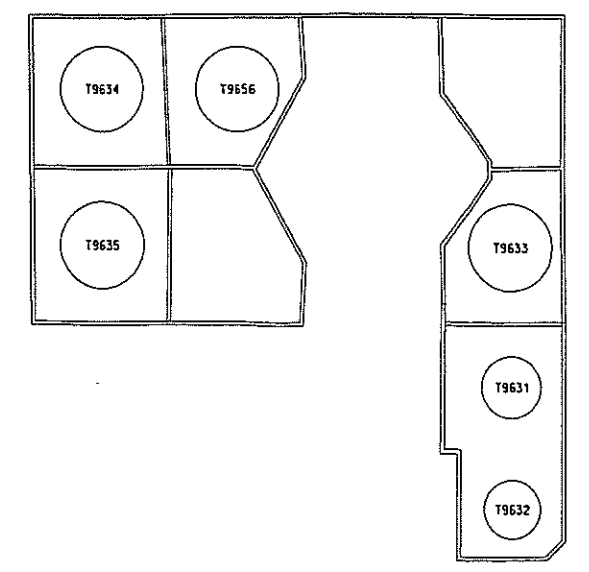
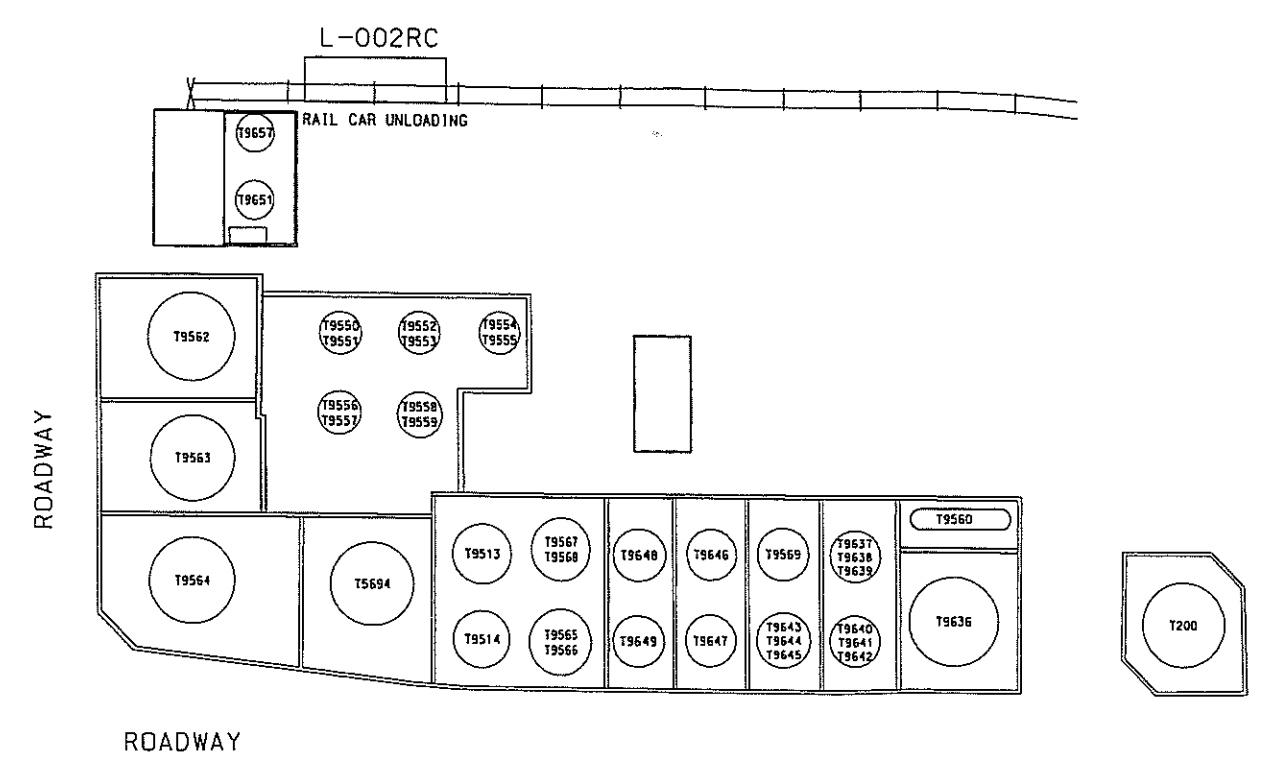
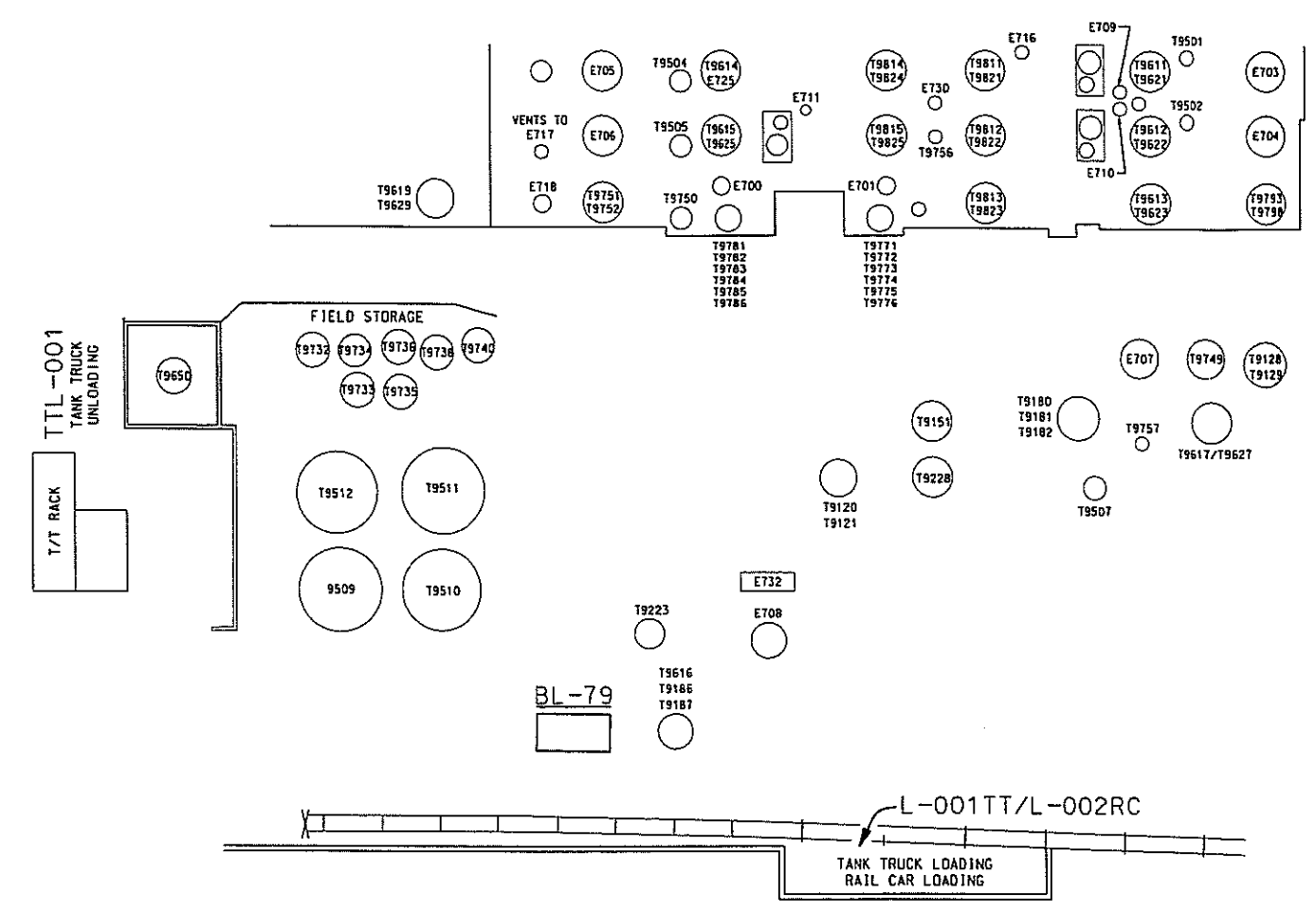
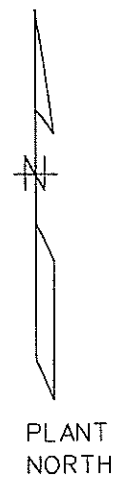

Ⓐ U.T.M. COORDINATES:
4,246,910 N; 439,660 E

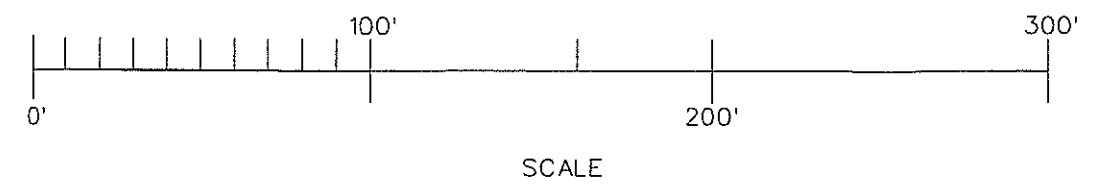

TITLE V	
UNION CARBIDE SOUTH CHARLESTON FACILITY	
PROCESS AREA ID 700	OXIDE ADDUCTS PLANT
MAINLAND CHEMICALS COMPLEX	

Union Carbide Corporation – South Charleston Chlorobenzene Remediation Area – Area 2 Attachment B – Plot Plan

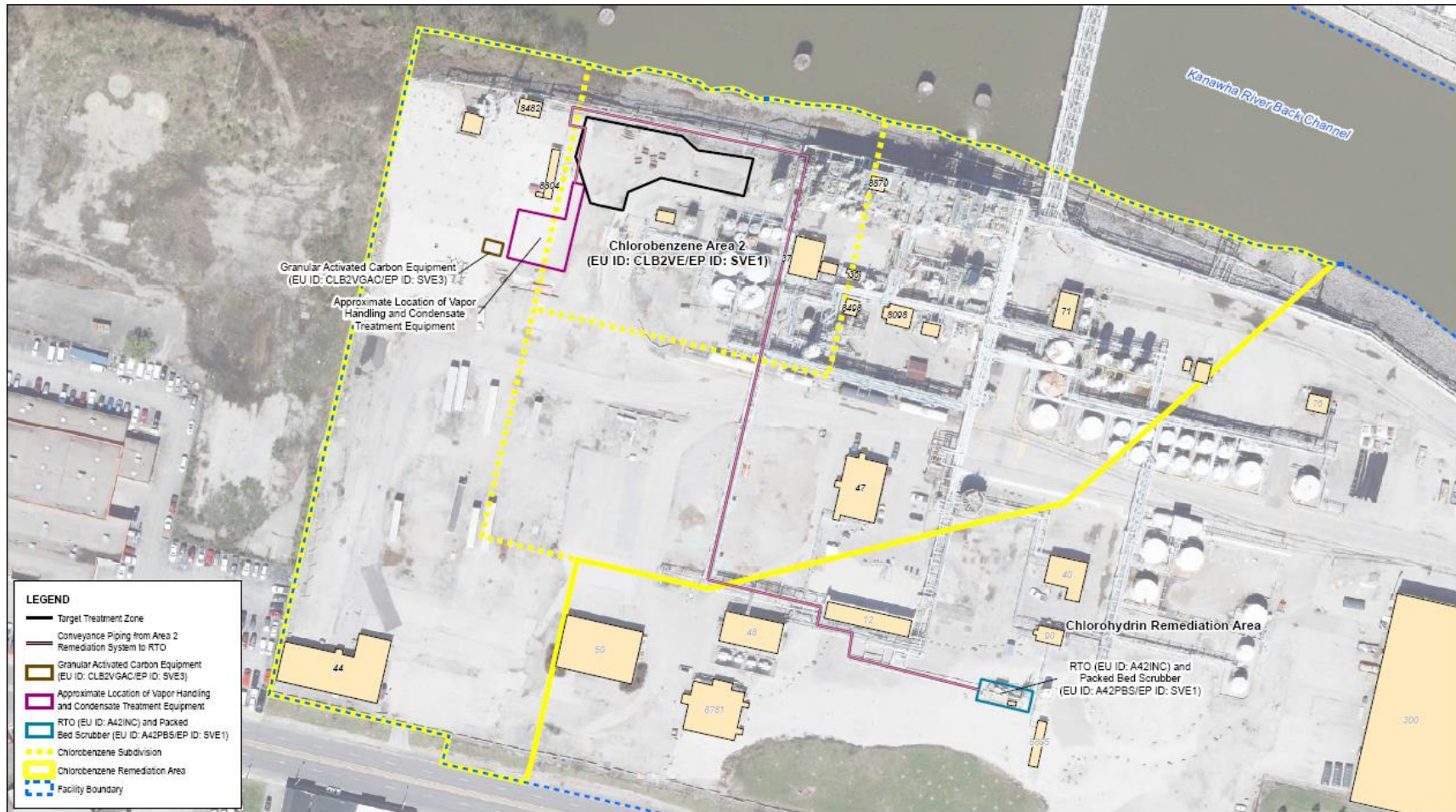

Notes:
 1. 2017 Aerial Photography provided by Kanawha County.
 2. Approximate coordinates for the Granular Activated Carbon Equipment are 439564 (Easting), 4247117 (Northing) in NAD 1983 UTM Zone 17S.
 3. Approximate Ground Surface Elevation in Vicinity of Treatment Equipment = 605 feet.

Figure 1.
 Chlorobenzene Remediation Area Layout
 Basis of Design for Chlorobenzene Remediation Area - Area 2
 UCC South Charleston Facility, South Charleston, West Virginia

ATTACHMENT B – PLOT PLAN CHLOROBENZENE REMEDIATION AREA

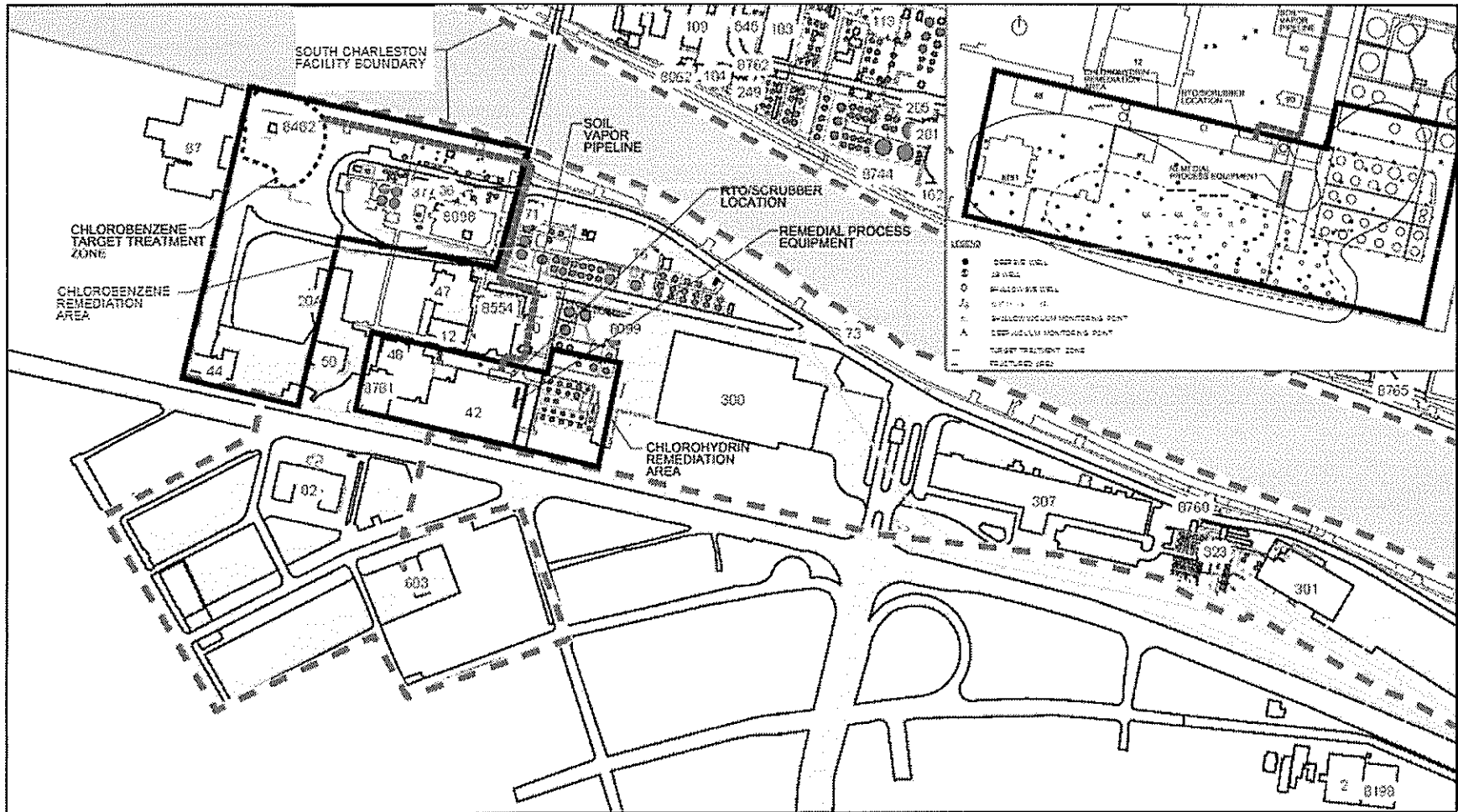

REMEDIATION OPERATIONS
ATTACHMENT B
PLOT PLAN



PLANT NORTH

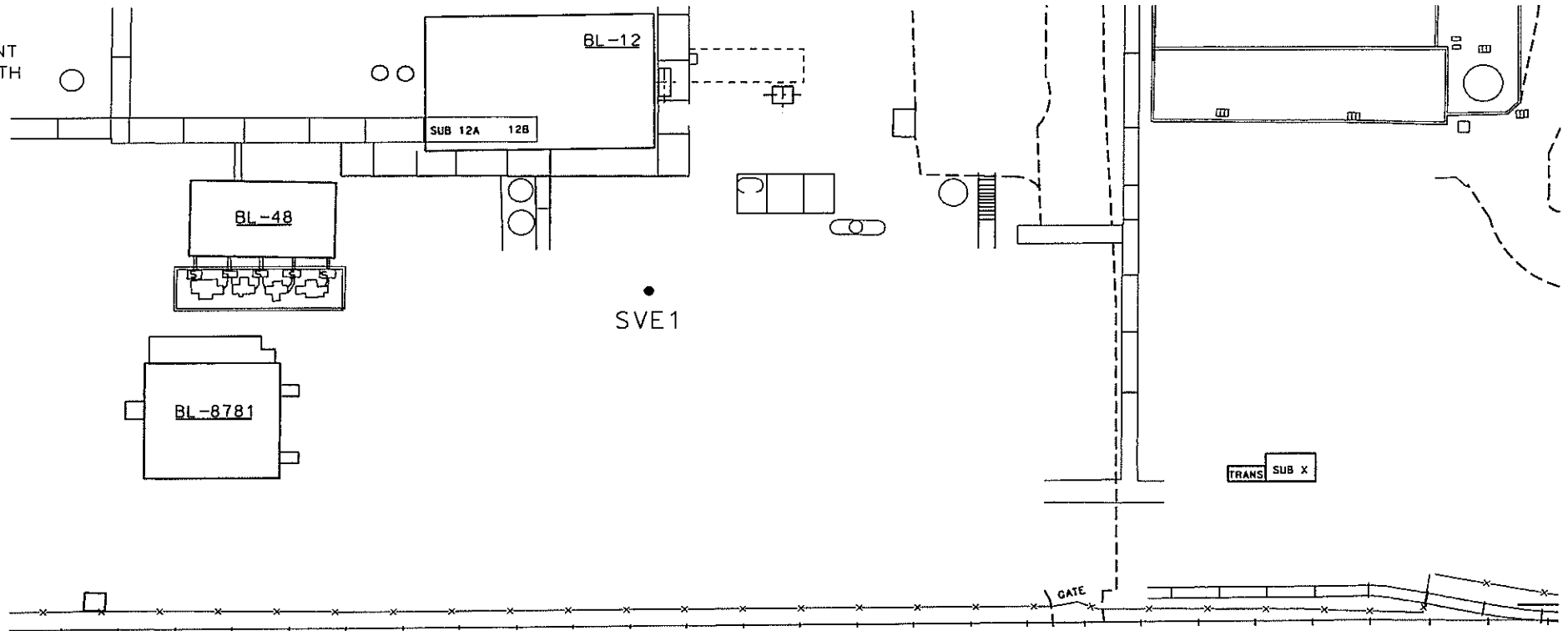

SCALE

TITLE V	
UNION CARBIDE SOUTH CHARLESTON FACILITY	
PROCESS AREA ID 042	REMEDIATION

ATTACHMENT B – PLOT PLAN MIDDLE ISLAND GROUNDWATER CONTAINMENT SYSTEM

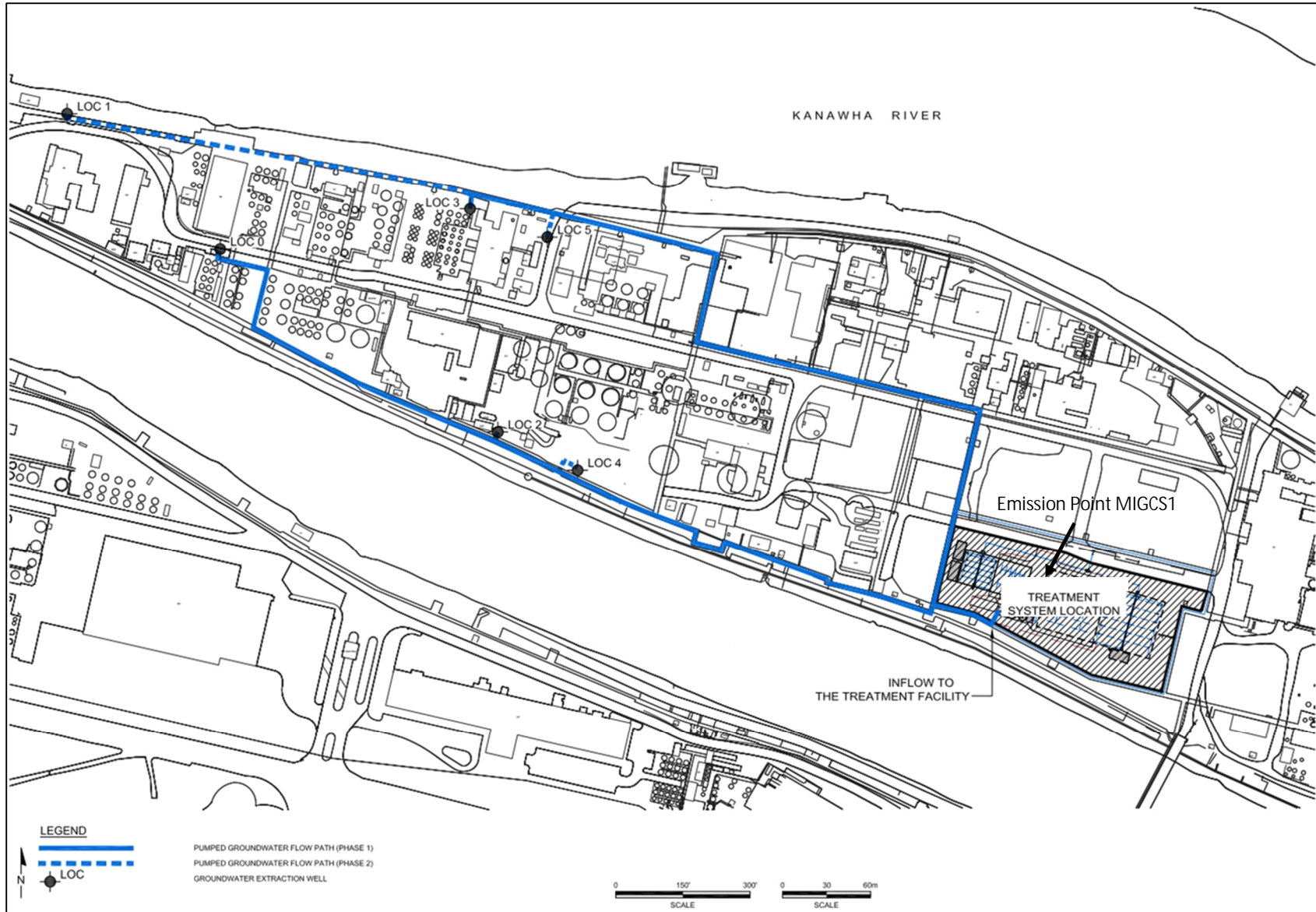

Remediation Operations - Middle Island Source 2
Attachment B - Plot Plan

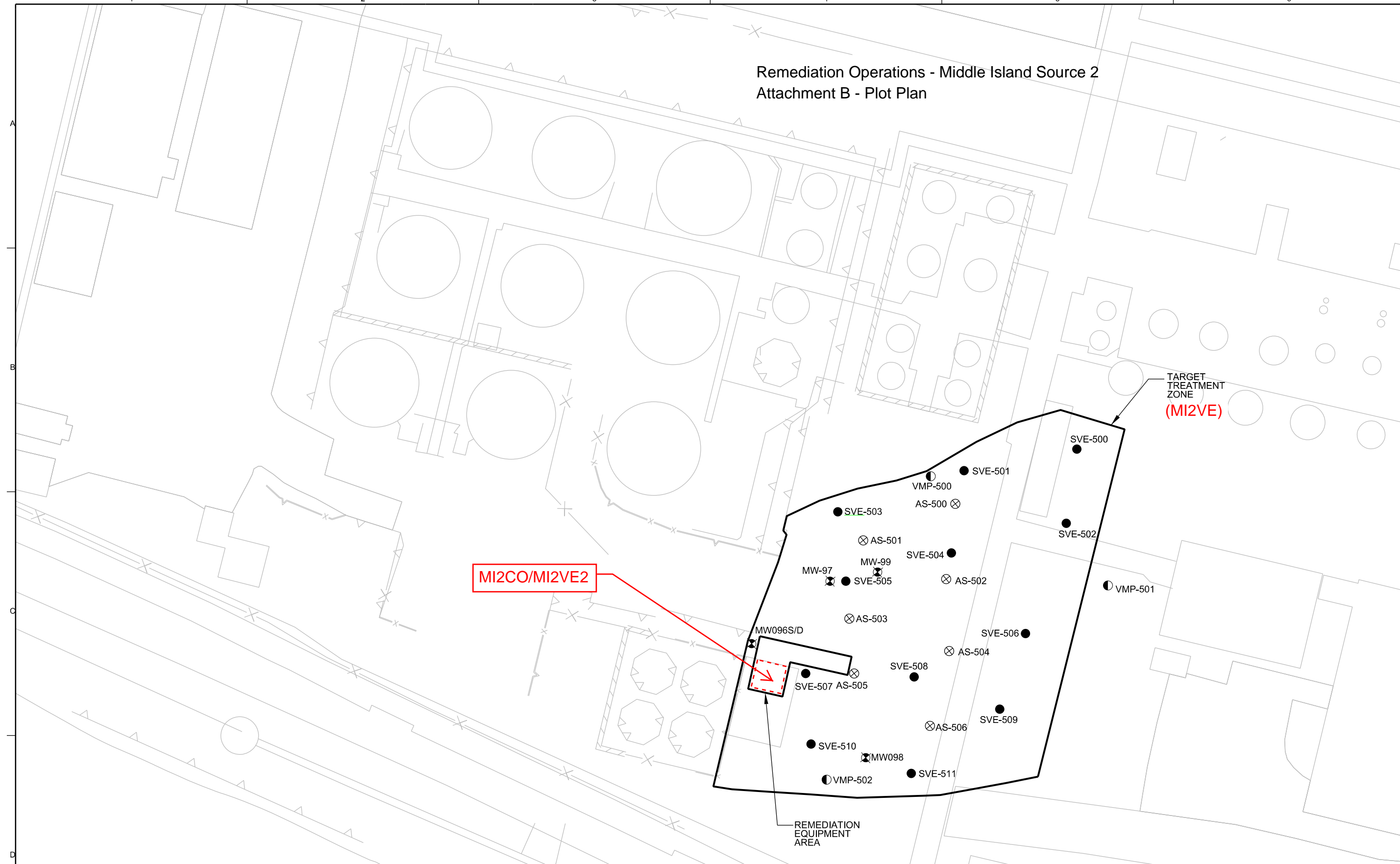

- LEGEND**
- ⊗ MONITORING WELLS
 - SOIL VAPOR EXTRACTION WELLS
 - ⊗ AIR SPARGE WELLS
 - VACUUM MONITORING POINT

NOTES

- WELLS HAVE BEEN INSTALLED APPROXIMATELY AS SHOWN. AS-BUILT LOCATIONS HAVE NOT BEEN SURVEYED.

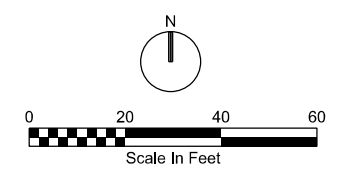

CH2MHILL CIVIL SITE PLAN		MIDDLE ISLAND SECOND SOURCE REMEDIATION AREA DESIGN SOUTH CHARLESTON FACILITY DOW CHEMICAL COMPANY SOUTH CHARLESTON, WEST VIRGINIA		NO. DATE DSGN	DATE CHK	DESCRIPTION REVISION	APVR BY APVD	N BY APVD	
		C. KATZEN DR	D. BELLARD-BENNETT CHK	J. HABERL APVD	J. HABERL BY APVD				
VERIFY SCALE BAR IS ONE INCH ON ORIGINAL DRAWING.		DATE PROJ DWG SHEET	JANUARY 2012 427976 C-201 7	REUSE OF DOCUMENTS: THIS DOCUMENT AND THE IDEAS AND DESIGNS INCORPORATED HEREIN, AS AN INSTRUMENT OF PROFESSIONAL SERVICE, IS THE PROPERTY OF CH2M HILL AND IS NOT TO BE USED, IN WHOLE OR IN PART, FOR ANY OTHER PROJECT WITHOUT THE WRITTEN AUTHORIZATION OF CH2M HILL. © CH2M HILL 2009. ALL RIGHTS RESERVED.					
60% DESIGN - BID DOCUMENTS		FILENAME: 005-C-201_427976.dgn PLOT DATE: 7/9/2012 PLOT TIME: 4:31:48 PM		FOR CONSTRUCTION					

SPECIALTY SURFACTANTS
ATTACHMENT B
PLOT PLAN

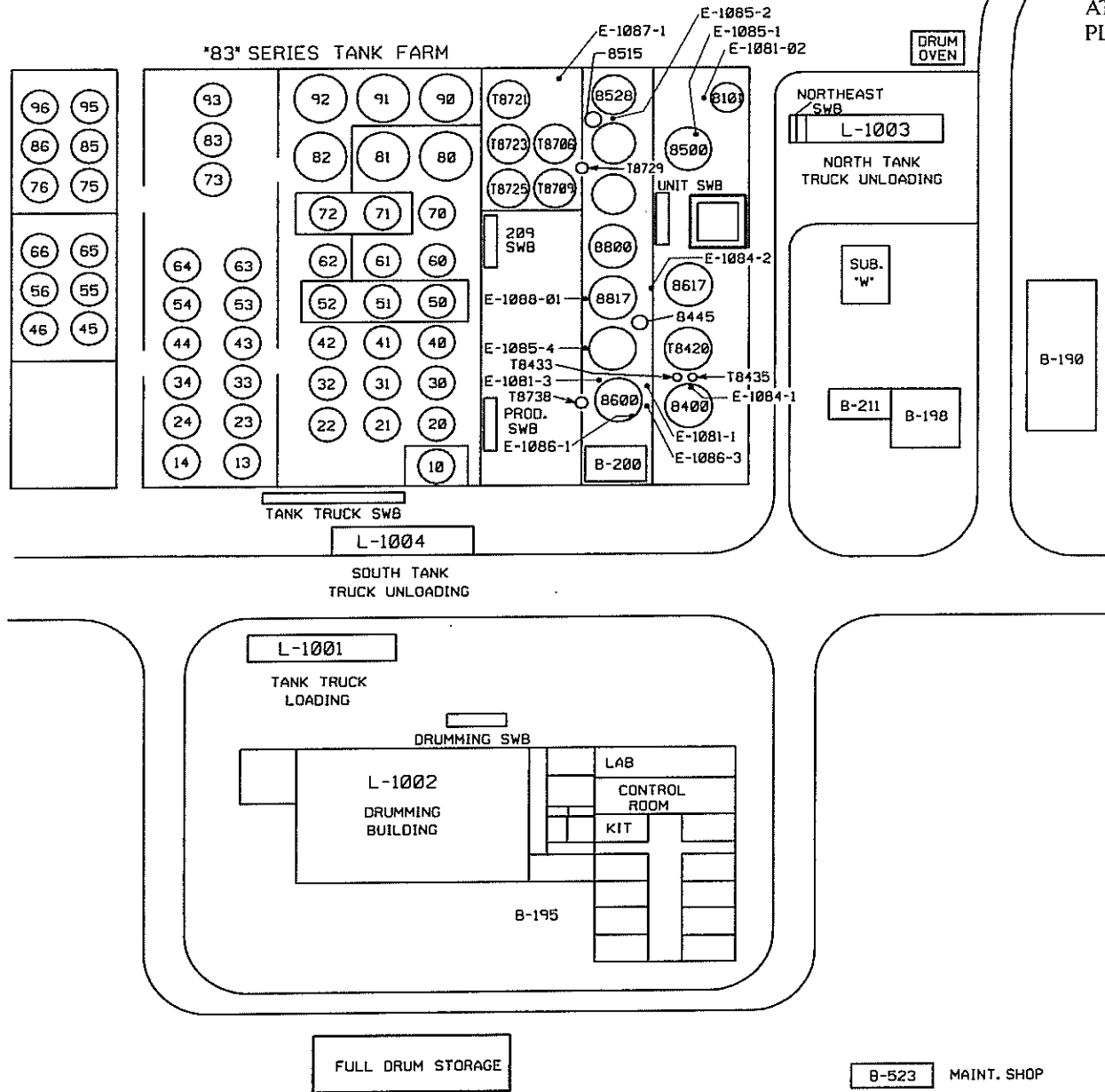

TITLE V	
UNION CARBIDE SOUTH CHARLESTON FACILITY	
PROCESS AREA ID 1000	SPECIALTY SURFACTANTS PLANT

Attachment C

Process Flow Diagram

ATTACHMENT C PROCESS FLOW DIAGRAM
 Union Carbide Corporation - Chemical Mixing Plant
 WVDAQ Regulation 30 Permit Renewal Application
 November 2016

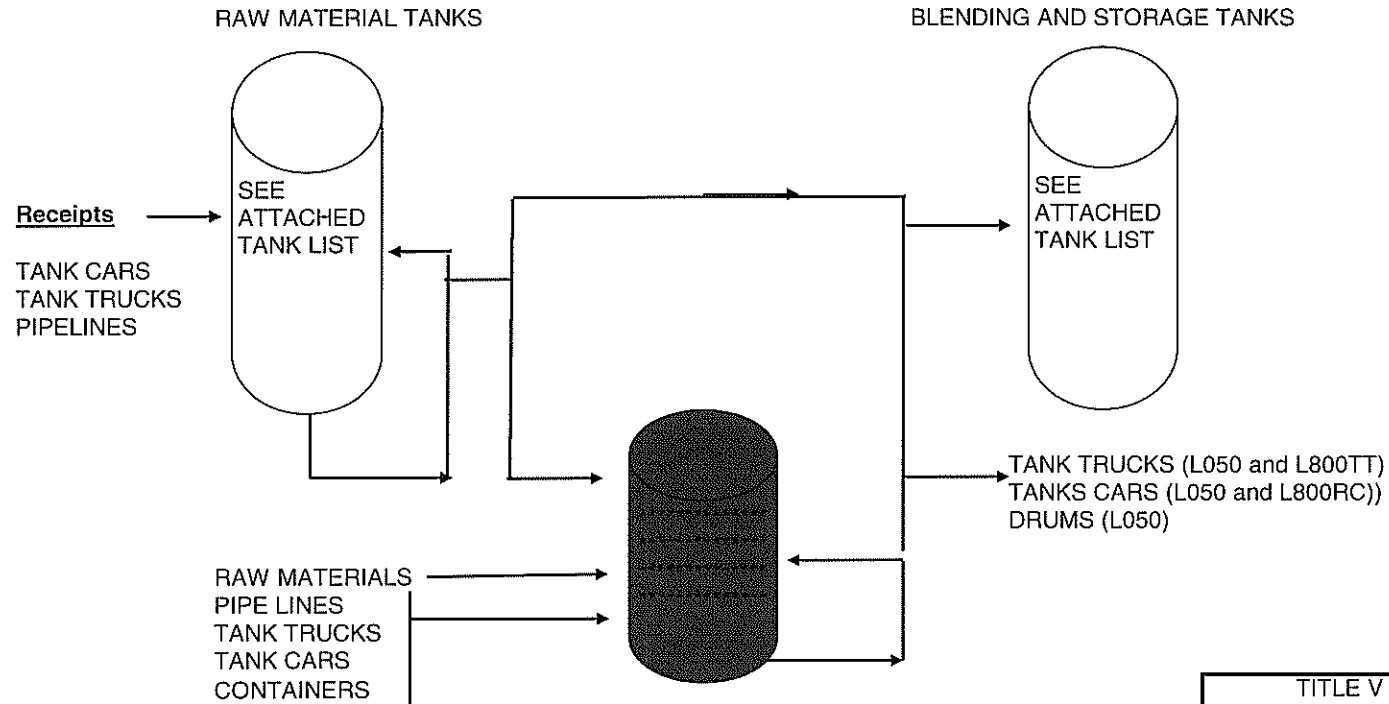

TITLE V PERMIT APPLICATION	
UNION CARBIDE	
SOUTH CHARLESTON PLANT	
PROCESS AREA ID	CHEMICAL MIXING
050	PLANT

ATTACHMENT C PROCESS FLOW DIAGRAM
UNION CARBIDE CORPORATION - SOUTH CHARLESTON FACILITY
WVDAQ Regulation 30 Permit Renewal Application

BOILER #26

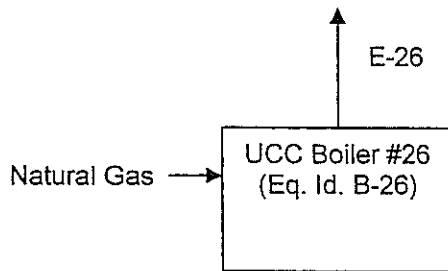

ATTACHMENT C PROCESS FLOW DIAGRAM
UNION CARBIDE CORPORATION - SOUTH CHARLESTON FACILITY
WVDAQ Regulation 30 Permit Renewal Application

BOILER #27

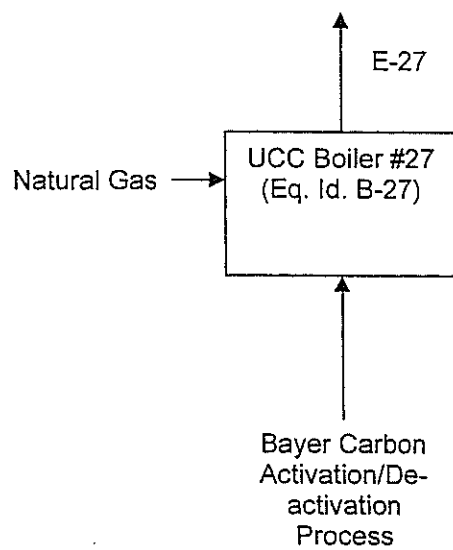

Union Carbide Corporation South Charleston Facility
North Charleston Distribution Facility

Attachment C; Process Flow Diagram

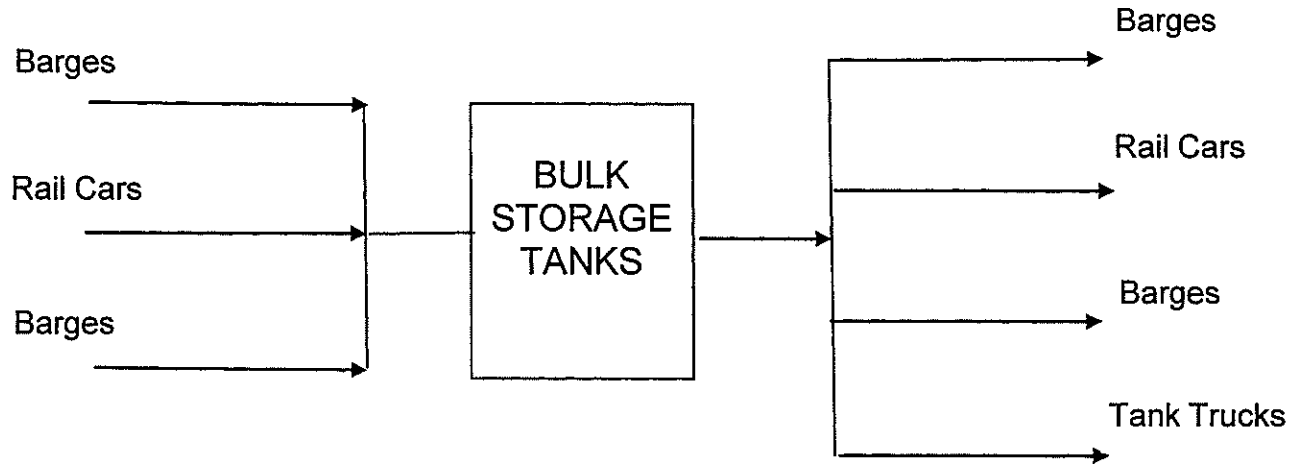

ATTACHMENT C PROCESS FLOW DIAGRAM
Union Carbide Corporation South Charleston Facility - Oxide Adducts Plant
WVDAQ Rule 30 Permit Renewal Application

Redacted Copy - Claim of Confidentiality

Process Flow Diagram
Oxide Adducts

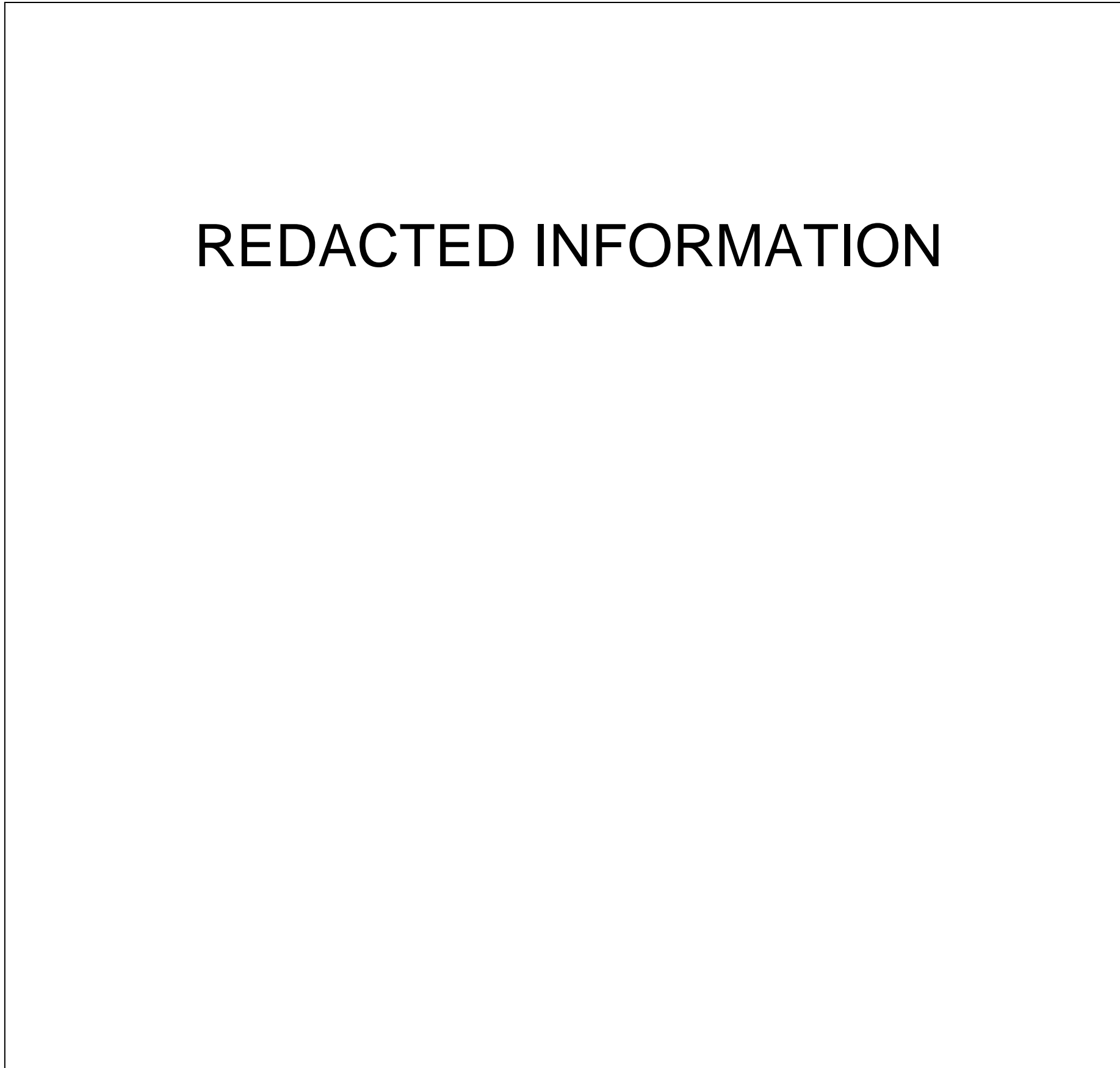

Title V Permit Application
Union Carbide Corporation South Charleston Plant
PAID 700 Oxide Adducts Plant

ATTACHMENT C - PROCESS FLOW DIAGRAM
Union Carbide Corporation - South Charleston Facility
WVDAQ Rule 30 Permit Application - MI Groundwater/Soil Remediation

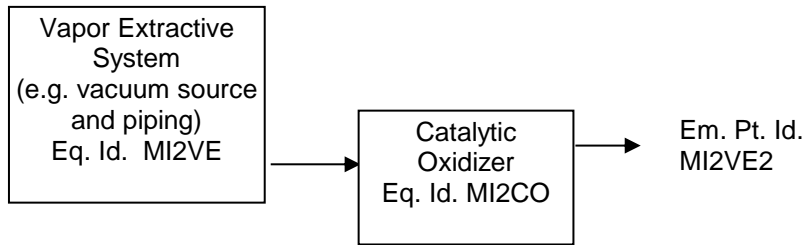

Union Carbide Corporation – South Charleston
WV - Chlorobenzene Remediation Area - Area 2

Attachment C - Process Flow Diagram

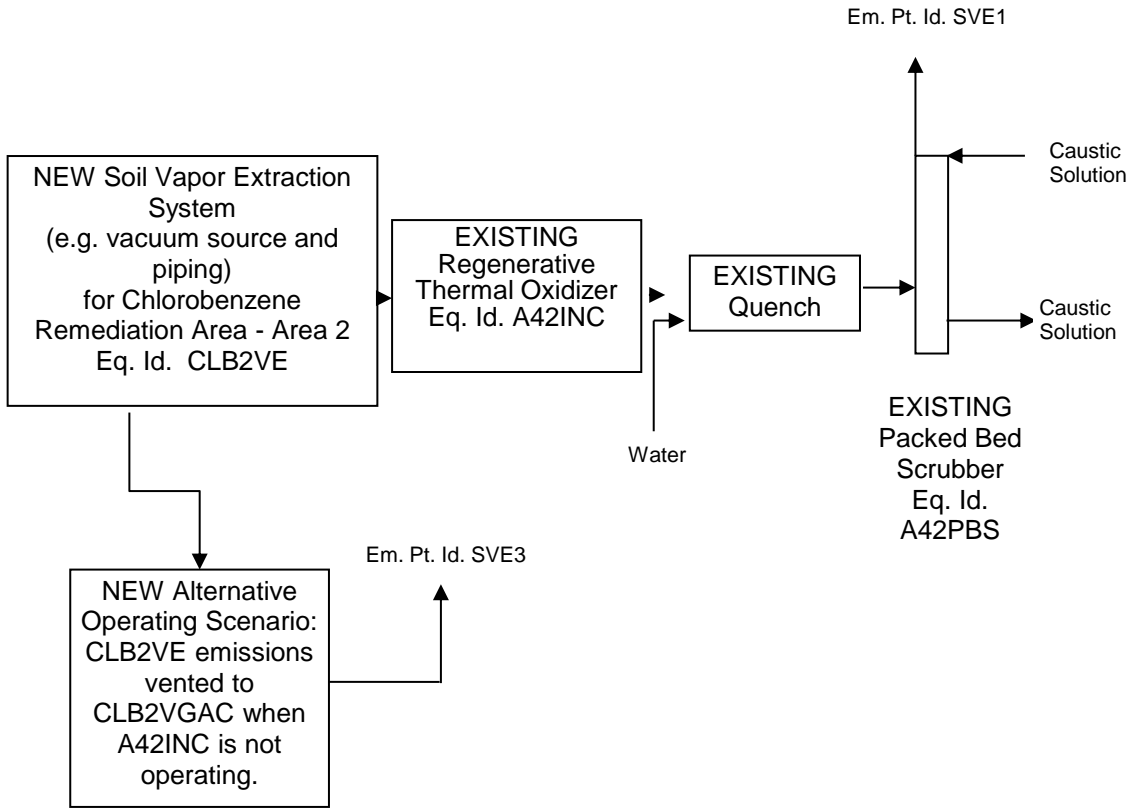

ATTACHMENT C - PROCESS FLOW DIAGRAM
Union Carbide Corporation - South Charleston Facility
Chlorohydrin/Chlorobenzene Groundwater/Soil Remediation

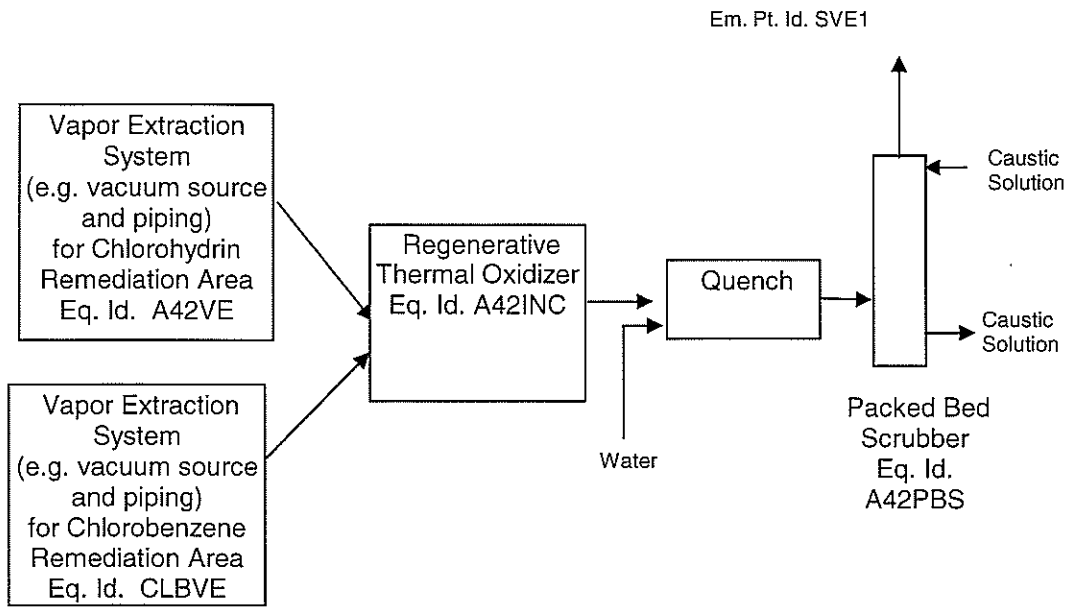

Attachment C - Process Flow Diagram

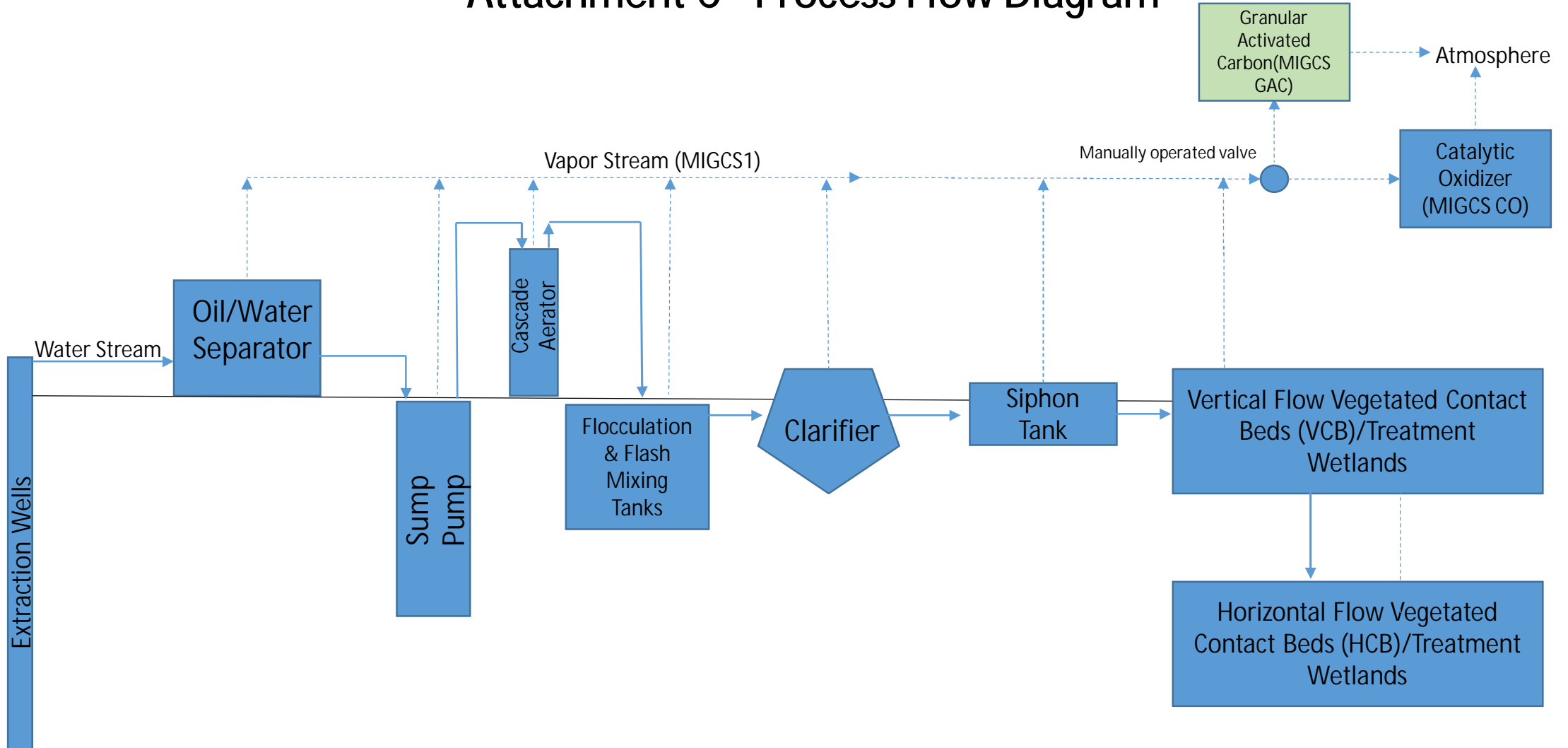

Specialty Surfactants - Triton Process Flow Diagram

Redacted Copy - Claim of Confidentiality

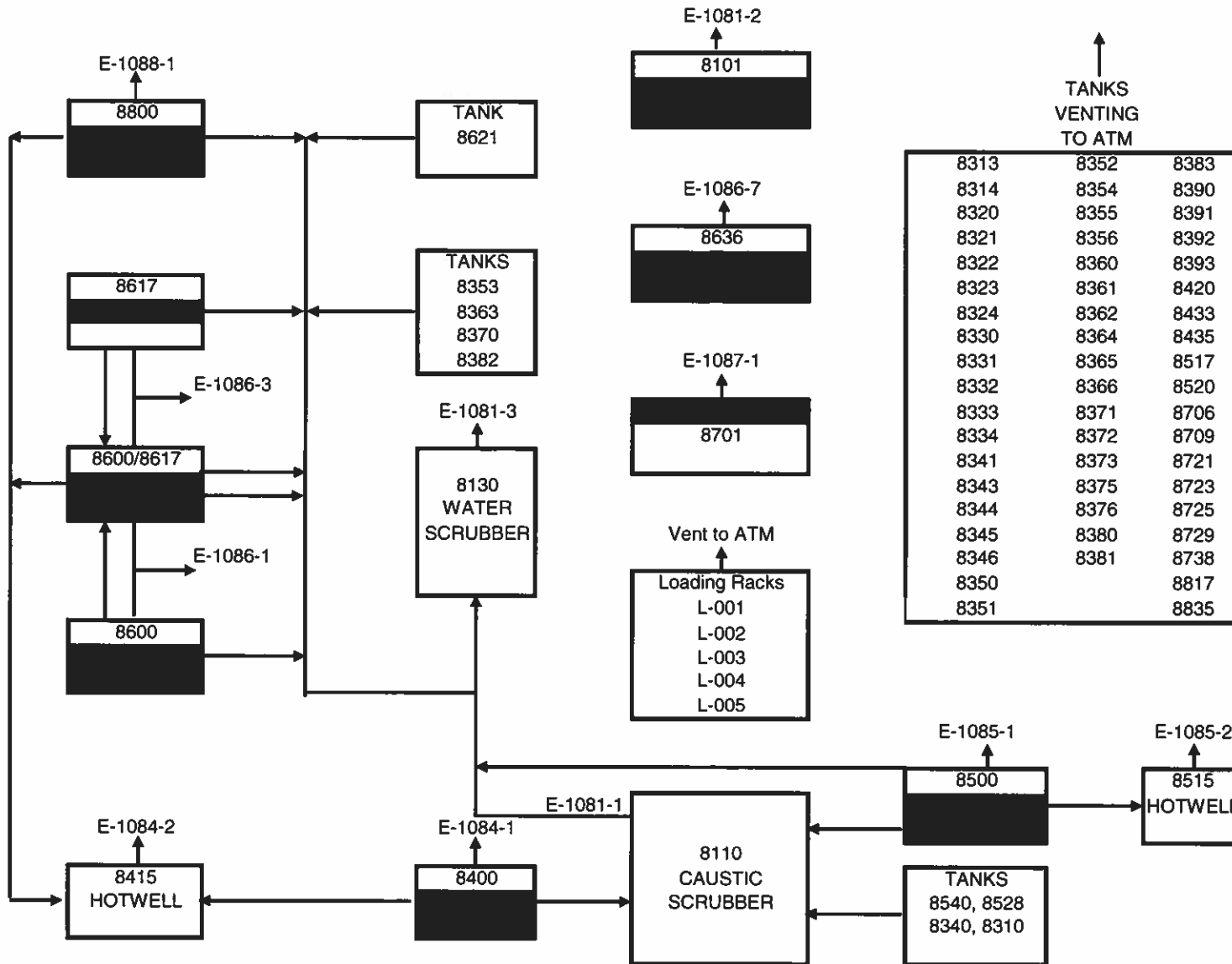

Attachment D

Equipment Table

ATTACHMENT D - Title V Equipment Table
 (includes all emission units at the facility except those designated as
 insignificant activities in Section 4, Item 24 of the General Forms)

Emission Point ID ¹	Control Device ¹	Emission Unit ID ¹	Emission Unit Description	Design or Nominal Capacity (gallons unless otherwise specified)	Year Installed/ Modified
2001E		2001	Tank 2001	██████	1962
2003E		2003	Tank 2003	██████	1962
2005E		2005	Tank 2005	██████	1962
2006E		2006	Tank 2006	██████	1962
2007E		2007	Tank 2007	██████	1962
2008E		2008	Tank 2008	██████	1945
2009E		2009	Tank 2009	██████	1962
2010E		2010	Tank 2010	██████	1968
2011E		2011	Tank 2011	██████	1962
2012E		2012	Tank 2012	██████	1962
2014E		2014	Tank 2014	██████	1962
2016E		2016	Tank 2016	██████	1962
2017E		2017	Tank 2017	██████	1956
2018E		2018	Tank 2018	██████	1956
2019E		2019	Tank 2019	██████	1953
2020E		2020	Tank 2020	██████	1953
2040E		2040	Tank 2040	██████	1962
2041E		2041	Tank 2041	██████	1962
2042E		2042	Tank 2042	██████	1962
2043E		2043	Tank 2043	██████	1962
2044E		2044	Tank 2044	██████	1962
2045E		2045	Tank 2045	██████	1962
2046E		2046	Tank 2046	██████	1962
2047E		2047	Tank 2047	██████	1962
2048E		2048	Tank 2048	██████	1962
2049E		2049	Tank 2049 (out of service)	██████	1962
2050E		2050	Tank 2050	██████	1966

Redacted Copy - Claim of Confidentiality
 Union Carbide Corporation South Charleston Facility: Chemical Mixing Plant

2051AE		2051A	Tank 2051A	██████	1967
2051BE		2051B	Tank 2051B (out of service)	██████	1967
2052E		2052	Tank 2052	██████	1962
2053E		2053	Tank 2053	██████	1962
2054E		2054	Tank 2054	██████	1962
2055E		2055	Tank 2055	██████	1962
2056E		2056	Tank 2056	██████	1962
2057E		2057	Tank 2057	██████	1962
2058E		2058	Tank 2058	██████	1962
2059E		2059	Tank 2059	██████	1962
2060E		2060	Tank 2060	██████	1962
2061E		2061	Tank 2061	██████	1975
2062E		2062	Tank 2062	██████	1962
2063E		2063	Tank 2063	██████	1962
2064E		2064	Tank 2064	██████	1962
2065E		2065	Tank 2065	██████	1962
2066E	-	2066	Tank 2066	██████	1962
9000E		9000	Tank 9000 located at NCDT (out of service)	██████	1956
SL-01E		SL-01	Vessel SL-01/ confidential	N/A	Nap
SL-02E		SL-02	Vessel SL-02/ confidential	N/A	Nap
SL-03E		SL-03	Vessel SL-03/ confidential	N/A	Nap
D-104E		D-104	Vessel D-104E/ confidential	N/A	Nap
TT050L		L050TT	In Unit Tank Truck Rack	N/A	Nap
RC050L		L050RC	In Unit Rail Car Rack	N/A	Nap
DR050L		L050DR	In Unit Drum Loading	N/A	Nap

¹For 45CSR13 permitted sources, the numbering system used for the emission points, control devices, and emission units should be consistent with the numbering system used in the 45CSR13 permit. For grandfathered sources, the numbering system should be consistent with registrations or emissions inventory previously submitted to DAQ. For emission points, control devices, and emissions units which have not been previously labeled, use the following 45CSR13 numbering system: 1S, 2S, 3S,... or other appropriate description for emission units; 1C, 2C, 3C,... or other appropriate designation for control devices; 1E, 2E, 3E, ... or other appropriate designation for emission points.

ATTACHMENT D - Title V Equipment Table
(includes all emission units at the facility except those designated as insignificant activities in Section 4, Item 24 of the General Forms)

Emission Point ID ¹	Control Device ¹	Emission Unit ID ¹	Emission Unit Description	Design Capacity	Year Installed/Modified
Energy Systems – Boilers & Compressors					
26E		B26 or E26	Natural Gas/Process Vent Gases Boiler #26	352 MM Btu/hr	1996
27E		B27 or E27	Natural Gas/Process Vent Gases Boiler #27	353 MM Btu/hr	1998
A-001		001	Portable diesel fueled auxiliary air compressors	575 hp*	Not Applicable
A-002		002	Portable diesel fueled auxiliary air compressors	575 hp*	Not Applicable
A-003		003	Portable diesel fueled auxiliary air compressors	575 hp*	Not Applicable
A-004		004	Portable diesel fueled auxiliary air compressors	575 hp*	Not Applicable
Pipelines					
		EOHDR	EO Distribution System		
Environmental Operations					
DP01E		DP01	Diesel Fueled Firewater Emergency Pump	Approx. 380 hp	Prior to 2002
DP02E		DP02	Diesel Fueled Firewater Emergency Pump	Approx. 380 hp	Prior to 2002
DP03E		DP03	Diesel Fueled Firewater Emergency Pump	Approx. 560 hp	Prior to 2002
		2707	Optisperse Tank – No regulated pollutants (boiler treatment)	3,000 gallons	1974

¹For 45CSR13 permitted sources, the numbering system used for the emission points, control devices, and emission units should be consistent with the numbering system used in the 45CSR13 permit. For grandfathered sources, the numbering system should be consistent with registrations or emissions inventory previously submitted to DAQ. For emission points, control devices, and emissions units which have not been previously labeled, use the following 45CSR13 numbering system: 1S, 2S, 3S,... or other appropriate description for emission units; 1C, 2C, 3C,... or other appropriate designation for control devices; 1E, 2E, 3E, ... or other appropriate designation for emission points.

*Up to four compressors authorized by Permit R13-2414A – horsepower rating is typical.

ATTACHMENT D - Title V Equipment Table

(includes all emission units at the facility except those designated as insignificant activities in Section 4, Item 24 of the General Forms)

Emission Point ID ¹	Control Device ¹	Emission Unit ID ¹	Emission Unit Description	Design Capacity	Year Installed/Modified
North Charleston Distribution (NCDT)					
T9000		9000	Tank 9000 [REDACTED] (out of service)	[REDACTED]	1956
Maintenance					
		B-307 Paint Booths	Building 307 Paint Booths for Small Parts	Not Applicable	
		B-307 Welding Shop	Building 307 Welding Shop	Not Applicable	
		Metal Solvent Cleaning Baths	Building 307 and miscellaneous locations	Not Applicable	

¹For 45CSR13 permitted sources, the numbering system used for the emission points, control devices, and emission units should be consistent with the numbering system used in the 45CSR13 permit. For grandfathered sources, the numbering system should be consistent with registrations or emissions inventory previously submitted to DAQ. For emission points, control devices, and emissions units which have not been previously labeled, use the following 45CSR13 numbering system: 1S, 2S, 3S,... or other appropriate description for emission units; 1C, 2C, 3C,... or other appropriate designation for control devices; 1E, 2E, 3E, ... or other appropriate designation for emission points.

ATTACHMENT D - Title V Equipment Table
(includes all emission units at the facility except those designated as
insignificant activities in Section 4, Item 24 of the General Forms)

Emission Point ID ¹	Control Device ¹	Emission Unit ID ¹	Emission Unit Description	Design Capacity (gallons unless otherwise specified)	Year Installed/ Modified
T9120		9120	Tank 9120	██████	1950
T9121		9121	Tank 9121	██████	1950
T9128		9128	Tank 9128	██████	1953
T9129		9129	Tank 9129	██████	1953
T9151		9151	Tank 9151	██████	1943
T9180		9180	Tank 9180	██████	1957
T9181		9181	Tank 9181	██████	1957
T9182		9182	Tank 9182	██████	1957
T9186		9186	Tank 9186	██████	1966
T9187		9187	Tank 9187	██████	1966
T9223		9223	Tank 9223	██████	1952
T9228		9228	Tank 9228	██████	1947
T9501		9501	Tank 9501	██████	1965
T9502		9502	Tank 9502	██████	1968
T9504		9504	Tank 9504	██████	1965
T9505		9505	Tank 9505	██████	1965
T9507		9507	Tank 9507	██████	1971
T9509		9509	Tank 9509	██████	1978
T9510		9510	Tank 9510	██████	1988
T9511		9511	Tank 9511	██████	1990
T9512		9512	Tank 9512	██████	1990
T9513		9513	Tank 9513	██████	1990
T9514		9514	Tank 9514	██████	1942
T9550		9550	Tank 9550	██████	1978
T9551		9551	Tank 9551	██████	1978
T9552		9552	Tank 9552	██████	1978

Union Carbide Corporation South Charleston Facility: Oxide Adducts Plant

T9553		9553	Tank 9553	██████	1978
T9554		9554	Tank 9554	██████	1978
T9555		9555	Tank 9555	██████	1978
T9556		9556	Tank 9556	██████	1967
T9557		9557	Tank 9557	██████	1967
T9558		9558	Tank 9558	██████	1967
T9559		9559	Tank 9559	██████	1967
T9560		9560	Tank 9560	██████	1961
T9562		9562	Tank 9562	██████	1950
T9563		9563	Tank 9563	██████	1972
T9564		9564	Tank 9564 (out of service)	██████	1972
T9565		9565	Tank 9565	██████	1954
T9566		9566	Tank 9566	██████	1957
T9567		9567	Tank 9567	██████	1953
T9568		9568	Tank 9568	██████	1953
T9569		9569	Tank 9569	██████	1966
T9611		9611	Tank 9611	██████	1966
T9612		9612	Tank 9612	██████	1966
T9613		9613	Tank 9613	██████	1966
T9614		9614	Tank 9614	██████	1966
T9615		9615	Tank 9615	██████	1966
T9616		9616	Tank 9616	██████	1966
T9617		9617	Tank 9617	██████	1967
T9619		9619	Tank 9619	██████	1967
T9621		9621	Tank 9621	██████	1966
T9622		9622	Tank 9622	██████	1966
T9623		9623	Tank 9623	██████	1966
T9624		9624	Tank 9624	██████	1966
T9625		9625	Tank 9625	██████	1966
T9627		9627	Tank 9627	██████	1967

Union Carbide Corporation South Charleston Facility: Oxide Adducts Plant

T9629		9629	Tank 9629		1967
T9631		9631	Tank 9631		1947
T9632		9632	Tank 9632		1947
T9633		9633	Tank 9633		1945
T9634		9634	Tank 9634		1951
T9635		9635	Tank 9635		1951
T9637		9637	Tank 9637		1947
T9638		9638	Tank 9638		1947
T9639		9639	Tank 9639		1947
T9640		9640	Tank 9640		1948
T9641		9641	Tank 9641		1948
T9642		9642	Tank 9642		1948
T9643		9643	Tank 9643		1942
T9644		9644	Tank 9644		1942
T9645		9645	Tank 9645		1942
T9646		9646	Tank 9646		1947
T9647		9647	Tank 9647		1946
T9648		9648	Tank 9648		1946
T9649		9649	Tank 9649		1946
T9650		9650	Tank 9650		1964
T9651		9651	Tank 9651		1952
T9656		9656	Tank 9656		1953
T9657		9657	Tank 9657		1956
T9732		9732	Tank 9732		1956
T9733		9733	Tank 9733		1957
T9734		9734	Tank 9734		1940
T9735		9735	Tank 9735		1950
T9736		9736	Tank 9736		1940
T9738		9738	Tank 9738		1966
T9740		9740	Tank 9740		1949
T9749		9749	Tank 9749		1957
T9750		9750	Tank 9750 (Sulfuric Acid)		1981
T9751		9751	Tank 9751		1966

Union Carbide Corporation South Charleston Facility: Oxide Adducts Plant

T9752		9752	Tank 9752	[REDACTED]	1966
T9756		9756	Tank 9756	[REDACTED]	Prior to 1984
T9757		9757	Tank 9757	[REDACTED]	2004
T9771		9771	Tank 9771	[REDACTED]	1966
T9772		9772	Tank 9772	[REDACTED]	1966
T9773		9773	Tank 9773	[REDACTED]	1966
T9774		9774	Tank 9774	[REDACTED]	1966
T9775		9775	Tank 9775	[REDACTED]	1966
T9776		9776	Tank 9776	[REDACTED]	1966
T9781		9781	Tank 9781	[REDACTED]	1966
T9782		9782	Tank 9782	[REDACTED]	1966
T9783		9783	Tank 9783	[REDACTED]	1966
T9784		9784	Tank 9784	[REDACTED]	1966
T9785		9785	Tank 9785	[REDACTED]	1966
T9786		9786	Tank 9786	[REDACTED]	1966
T9793		9793	Tank 9793	[REDACTED]	1964
T9798		9798	Tank 9798	[REDACTED]	1964
T9811		9811	Tank 9811	[REDACTED]	1966
T9812		9812	Tank 9812	[REDACTED]	1966
T9813		9813	Tank 9813	[REDACTED]	1966
T9814		9814	Tank 9814	[REDACTED]	1966
T9815		9815	Tank 9815	[REDACTED]	1966
T9821		9821	Tank 9821	[REDACTED]	1966
T9822		9822	Tank 9822	[REDACTED]	1966
T9823		9823	Tank 9823	[REDACTED]	1966
T9824		9824	Tank 9824	[REDACTED]	1966
T9825		9825	Tank 9825	[REDACTED]	1966
T5694		5694	Tank 5694 (from AA)	OOS	OOS
T9636		9636	Tank 9636 (from AA)	OOS	OOS
T200		200	Tank 200 (from AA)	OOS	OOS
E700		P700	Prep System 1	[REDACTED]	1970
E701		P701	Prep System 2	[REDACTED]	1970
E716		P716	Prep System 3	[REDACTED]	1970

Title V Equipment Table (equipment_table.doc)

Redacted Copy – Claim of Confidentiality

Union Carbide Corporation South Charleston Facility: Oxide Adducts Plant

E703		R703	Reactor 1	██████	1970
E704		R704	Reactor 2	██████	1970
E705		R705	Reactor 4	██████	1970
E706		R706	Reactor 5	██████	1970
E708		R708	Reactor 6	██████	1995
E707		R707	Reactor 7	██████	1971
E709	C709 and/or None	721T	#1 Product Treatment Emiss. Pt. for Vac Jet	NAP - multiple equipment pieces	1970
E710	C710 and/or None	722T	#2 Product Treatment Emiss. Pt. for Vac Jet	NAP - multiple equipment pieces	1970
E711	C711 and/or None	723T	#5 Product Treatment Emiss. Pt. for Vac Jet	NAP - multiple equipment pieces	1970
E730		730HW	Hotwell System	not applicable	Nap
E732		732T	Other Treatment	7.5 ft by 2 ft by 2 ft	1970
E717		717R1	Recovery and Refining Systems 1	nap - multiple equipment pieces	1970
E718		717R2	Recovery and Refining Systems 2	approximately ██████ gallons	1970
L001TT		L001	Tank Truck Transfer Rack	Not Applicable	Nap
L002RC		L002	Rail Car Transfer Rack	Not Applicable	Nap
E709 and/or E730	C709		#1 Jets/Condenser	Not Applicable	Nap
E710 and/or E730	C710		#2 Jets/Condenser	Not Applicable	Nap
E711 and/or E730	C711		#5 Jets/Condenser	Not Applicable	Nap
E703A - Virtual Emission Point for #1 Reactor Drop Tanks		Misc Drop Tanks 1	R27 CO Process Id. E703A	Not Applicable	Nap
E704A - Virtual Emission Point for #2 Reactor Drop Tanks		Misc Drop Tanks 2	R27 CO Process Id. E704A	Not Applicable	Nap

Union Carbide Corporation South Charleston Facility: Oxide Adducts Plant

E705A - Virtual Emission Point for #4 Reactor Drop Tanks		Misc Drop Tanks 4	R27 CO Process Id. E705A	Not Applicable	Nap
E706A - Virtual Emission Point for #5 Reactor Drop Tanks		Misc Drop Tanks 5	R27 CO Process Id. E706A	Not Applicable	Nap
E707A - Virtual Emission Point for #7 Reactor Drop Tanks		Misc Drop Tanks 7	R27 CO Process Id. E707A	Not Applicable	Nap
E708A - Virtual Emission Point for #6 Reactor Drop Tanks		Misc Drop Tanks 6	R27 CO Process Id. E708A	Not Applicable	Nap
E703B - Virtual Emission Point for #1 Reactor Product Treatment		Product Treatment 1, 2, 5, and/or Other Treatment 1	R27 CO Process Id. E703B Virtual because can treat products from reactor 1 in treater 2 or 5	Not Applicable	Nap
E704B- Virtual Emission Point for #2 Reactor Product Treatment		Product Treatment 1, 2, 5, and/or Other Treatment 2	R27 CO Process Id. E704B	Not Applicable	Nap
E705B- Virtual Emission Point for #4 Reactor Product Treatment		Product Treatment 1, 2, 5, and/or Other Treatment 4	R27 CO Process Id. E705B	Not Applicable	Nap
E706B- Virtual Emission Point for #5 Reactor Product Treatment		Product Treatment 1, 2, 5, and/or Other Treatment 5	R27 CO Process Id. E706B	Not Applicable	Nap

Redacted Copy – Claim of Confidentiality

Union Carbide Corporation South Charleston Facility: Oxide Adducts Plant

E707B- Virtual Emission Point for #7 Reactor Product Treatment		Product Treatment 1, 2, 5, and/or Other Treatment 7	R27 CO Process Id. E707B	Not Applicable	Nap
E708B- Virtual Emission Point for #6 Reactor Product Treatment		Product Treatment 1, 2, 5, and/or Other Treatment 6	R27 CO Process Id. E708B	Not Applicable	Nap

¹For 45CSR13 permitted sources, the numbering system used for the emission points, control devices, and emission units should be consistent with the numbering system used in the 45CSR13 permit. For grandfathered sources, the numbering system should be consistent with registrations or emissions inventory previously submitted to DAQ. For emission points, control devices, and emissions units which have not been previously labeled, use the following 45CSR13 numbering system: 1S, 2S, 3S,... or other appropriate description for emission units; 1C, 2C, 3C,... or other appropriate designation for control devices; 1E, 2E, 3E, ... or other appropriate designation for emission points.

ATTACHMENT D - Title V Equipment Table
 (includes all emission units at the facility except those designated as insignificant activities in Section 4, Item 24 of the General Forms)

Emission Point ID ¹	Control Device ¹	Emission Unit ID ¹	Emission Unit Description	Design Capacity	Year Installed/ Modified
SVE1	A42INC and A42PBS	CLBVE	Vapor Extraction System - Chlorobenzene Area	600 scfm	2014
SVE2 (Vents to Atmosphere)	None	CLBVE	Vapor Extraction System – Chlorobenzene Area (Alternative Operating Scenario)	600 scfm	2019
SVE1	A42INC and A42PBS	A42VE	Vapor Extractive System- Chlorohydrin Area (Area 42)	1,050 scfm	2011
SVE1	A42PBS	A42INC	Regenerative Thermal Oxidizer (Incinerator)	Not Applicable	2011
SVE1	A42PBS		Packed Bed Caustic Scrubber	Not Applicable	2011
MI2VE2	MI2CO	MI2VE	Vapor Extraction System	1,000 scfm	2014
MI2VE2	MI2CO	MI2CO	Catalytic Oxidizer	Not Applicable	2014
MIGCS1/ MIGCS2	MIGCSO/ MIGCSGAC	MIGCS	MI Groundwater Containment System	100 gpm	2017
MIGCS2		MIGCSGAC	Granular Activated Carbon	500 scfm	2018
MIGCS1		MIGCS CO	Anguil Model OA10 (Electric Catalytic Oxidizer) (CATOX)	1,000 scfm	2017
SVE3	A42INC and A45PBS or CLB2VGAC	CLB2VE	Vapor Extraction System – Chlorobenzene Area 2	800 scfm	Future (2022)

¹For 45CSR13 permitted sources, the numbering system used for the emission points, control devices, and emission units should be consistent with the numbering system used in the 45CSR13 permit. For grandfathered sources, the numbering system should be consistent with registrations or emissions inventory previously submitted to DAQ. For emission points, control devices, and emissions units which have not been previously labeled, use the following 45CSR13 numbering system: 1S, 2S, 3S,... or other appropriate description for emission units; 1C, 2C, 3C,... or other appropriate designation for control devices; 1E, 2E, 3E, ... or other appropriate designation for emission points.

ATTACHMENT D - Title V Equipment Table

(includes all emission units at the facility except those designated as insignificant activities in Section 4, Item 24 of the General Forms)

Emission Point ID ¹	Control Device ¹	Emission Unit ID ¹	Emission Unit Description	Design Capacity (gallons unless otherwise specified)	Year Installed/Modified
E-1081-2	C8105	8101	Vessel 8101/Refining Still	██████	1977
E-1081-3	C8110 and C8130	8310	Tank 8310	██████	1992
T8313		8313	Tank 8313	██████	1959
T8314		8314	Tank 8314	██████	1959
T8320		8320	Tank 8320	██████	1959
T8321		8321	Tank 8321	██████	1944
T8322		8322	Tank 8322	██████	1944
T8323		8323	Tank 8323	██████	1959
T8324		8324	Tank 8324	██████	1959
T8830		8330	Tank 8330	██████	1976
T8331		8331	Tank 8331	██████	1976
T8332		8332	Tank 8332	██████	1976
T8333		8333	Tank 8333	██████	1959
T8334		8334	Tank 8334	██████	1959
E-1081-3	C8110 and C8130	8340	Tank 8340	██████	1944
T8341		8341	Tank 8341	██████	1944
T8343		8343	Tank 8343	██████	1959
T8344		8344	Tank 8344	██████	1959
T8345		8345	Tank 8345 (out of service)	██████	1959
T8346		8346	Tank 8346 (out of service)	██████	1959
T8350		8350	Tank 8350	██████	1944
T8351		8351	Tank 8351	██████	1944
T8352		8352	Tank 8352	██████	1945
E-1081-3	C8130	8353	Tank 8353	██████	1959
T8354		8354	Tank 8354	██████	1959

Redacted Copy – Claim of Confidentiality

Union Carbide Corporation South Charleston Facility: TRITON® Plant

T8355		8355	Tank 8355 (out of service)	██████	1959
T8356		8356	Tank 8356 (out of service)	██████	1959
T8360		8360	Tank 8360	██████	1962
T8361		8361	Tank 8361	██████	1944
T8362		8362	Tank 8362	██████	1942
E-1081-3	C8130	8363	Tank 8363	██████	1959
T8364		8364	Tank 8364	██████	1959
T8365		8365	Tank 8365 (out of service)	██████	1959
T8366		8366	Tank 8366 (out of service)	██████	1959
E-1081-3	C8130	8370	Tank 8370	██████	1975
T8371		8371	Tank 8371	██████	1976
T8372		8372	Tank 8372 (sulfuric acid)	██████	1948
T8373		8373	Tank 8373	██████	1952
T8375		8375	Tank 8375 (out of service)	██████	1959
T8376		8376	Tank 8376 (out of service)	██████	1959
T8380		8380	Tank 8380	██████	1976
T8381		8381	Tank 8381	██████	1976
E-1081-3	C8130	8382	Tank 8382	██████	1993
T8383		8383	Tank 8383	██████	1952
T8390		8390	Tank 8390	██████	1976
T8391		8391	Tank 8391	██████	1976
T8392		8392	Tank 8392	██████	1977
T8393		8393	Tank 8393	██████	1952
E-1084-1 or E-1084-2 or E-1081-3	C8110 and C8130 or none	8400	8400 Reactor	██████	1976
E-1084-2		8415	Triad Hotwell	Not applicable	Not applicable
T8420		8420	Tank 8420	██████	1976
T8433		8433	Tank 8433 (Phosphoric Acid)	██████	1993
T8345		8435	Tank 8345	██████	1993

Redacted Copy – Claim of Confidentiality

Union Carbide Corporation South Charleston Facility: TRITON® Plant

E-1085-1 or E-1085-2 or E-1081-3	C8110 or C8130 and C8110 or none	8500	8500 Reactor		1976
E-1085-2		8515	LCAP Hotwell	Not applicable	Not applicable
		8518	East Filter Press		1993
E-1085-4 (shared with 8835)		8520	Tank 8520		1993
E-1081-3	C8110 and C8130	8528	Tank 8528		1975
E-1081-3	C8110 and C8130	8540	Tank 8540		1994
E-1081-3 or E-1084-2 or E-1086-1	C8130 or none	8600	8600 Reactor		1976
E-1081-3 or E-1084-2 or E-1086-3	C8130 or none	8617	8617 Reactor		1976
E-1081-3	C8130	8621	Tank 8621		1976
E-1087-1	C1087	8701	Bin 8701 (out of service)		1993
E-1087-2		8706	Tank 8706 (out of service)		1993
E-1087-3		8709	Tank 8709 (out of service)		1993
T8721		8721	Tank 8721 (out of service)		1993
T8723		8723	Tank 8723 (out of service)		1993
T8725		8725	Tank 8725 (out of service)		1993
T8729		8729	Tank 8729 – No Regulated Pollutant (out of service)		1993
T8738		8738	Tank 8738	Not applicable	Not applicable
			Process Funnel for Tank 8738	Not applicable	Not applicable

Redacted Copy – Claim of Confidentiality

Union Carbide Corporation South Charleston Facility: TRITON® Plant

E-1088-1 or E-1084-2 or E-1081-3	C8130 or none	8800	8800 Reactor		1976
T8817		8817	Tank 8817		1976
		8820	West Filter Press		1993
			Bin 8629 (Hopper for Na Meta Sulfit)	Not applicable	Not applicable
E-1085-4 (shared with 8520)		8835	Tank 8835		1993
			Funnel for Tank 8835	Not applicable	Not applicable
E-1087-1	C1087		Baghouse	Not applicable	Not applicable
E-1081-1 or E-1081-3	C8110		Caustic Scrubber	Not applicable	1976
E-1081-3	C8130		Water Scrubber	Not applicable	1976
E-1081-02	C8105		Condenser	Not applicable	Not applicable
		L1001	Loading Rack L1001	Not applicable	Not applicable
		L1002	Loading Rack L1002	Not applicable	Not applicable
		L1003	Loading Rack L1003	Not applicable	Not applicable
To atm., or E-1081-1		L1004	Loading Rack L1004	Not applicable	Not applicable
		L1005	Loading Rack L1005 (not located within TRITON plant)	Not applicable	Not applicable

¹For 45CSR13 permitted sources, the numbering system used for the emission points, control devices, and emission units should be consistent with the numbering system used in the 45CSR13 permit. For grandfathered sources, the numbering system should be consistent with registrations or emissions inventory previously submitted to DAQ. For emission points, control devices, and emissions units which have not been previously labeled, use the following 45CSR13 numbering system: 1S, 2S, 3S,... or other appropriate description for emission units; 1C, 2C, 3C,... or other appropriate designation for control devices; 1E, 2E, 3E, ... or other appropriate designation for emission points.

Attachment E

Emission Units

ATTACHMENT E - Emission Unit Form

Emission Unit Description: Storage Tank

Emission unit ID number: 2041	Emission unit name: Tank 2041	List any control devices associated with this emission unit:
---	---	---

Provide a description of the emission unit (type, method of operation, design parameters, etc.):

Storage of volatile organic liquid

Manufacturer:	Model number:	Serial number:
Construction date: See Attachment D Equipment Table	Installation date: See Attachment D Equipment Table	Modification date(s): See Attachment D Equipment Table

Design Capacity (examples: furnaces - tons/hr, tanks - gallons): See Attachment D Equipment Table

Maximum Hourly Throughput:	Maximum Annual Throughput:	Maximum Operating Schedule: 24 hrs/day, 365 days/yr
-----------------------------------	-----------------------------------	---

Fuel Usage Data (fill out all applicable fields)

Does this emission unit combust fuel? ___ Yes <u> X </u> No	If yes, is it? ___ Indirect Fired ___ Direct Fired
Maximum design heat input and/or maximum horsepower rating:	Type and Btu/hr rating of burners:

List the primary fuel type(s) and if applicable, the secondary fuel type(s). For each fuel type listed, provide the maximum hourly and annual fuel usage for each.

Describe each fuel expected to be used during the term of the permit.

Fuel Type	Max. Sulfur Content	Max. Ash Content	BTU Value

Union Carbide Corporation South Charleston Facility – Chemical Mixing Plant

<i>Emissions Data</i>		
Criteria Pollutants	Potential Emissions	
	PPH	TPY
Carbon Monoxide (CO)		
Nitrogen Oxides (NO _x)		
Lead (Pb)		
Particulate Matter (PM _{2.5})		
Particulate Matter (PM ₁₀)		
Total Particulate Matter (TSP)		
Sulfur Dioxide (SO ₂)		
Volatile Organic Compounds (VOC)		
Hazardous Air Pollutants	Potential Emissions	
	PPH	TPY
Regulated Pollutants other than Criteria and HAP	Potential Emissions	
	PPH	TPY

List the method(s) used to calculate the potential emissions (include dates of any stack tests conducted, versions of software used, source and dates of emission factors, etc.).

Applicable Requirements

List all applicable requirements for this emission unit. For each applicable requirement, include the underlying rule/regulation citation and/or construction permit with the condition number. (Note: Title V permit condition numbers alone are not the underlying applicable requirements). If an emission limit is calculated based on the type of source and design capacity or if a standard is based on a design parameter, this information should also be included.

See Attachment I for applicable requirements, monitoring, recordkeeping, reporting and testing from existing Title V permit.

Permit Shield

For all applicable requirements listed above, provide monitoring/testing/recordkeeping/reporting which shall be used to demonstrate compliance. If the method is based on a permit or rule, include the condition number or citation. (Note: Each requirement listed above must have an associated method of demonstrating compliance. If there is not already a required method in place, then a method must be proposed.)

See Attachment I for applicable requirements, monitoring, recordkeeping, reporting and testing from existing Title V permit.

Are you in compliance with all applicable requirements for this emission unit? Yes No

If no, complete the **Schedule of Compliance Form** as ATTACHMENT F.

ATTACHMENT E - Emission Unit Form

Emission Unit Description: Storage Tank

Emission unit ID number: 2045	Emission unit name: Tank 2045	List any control devices associated with this emission unit:
---	---	---

Provide a description of the emission unit (type, method of operation, design parameters, etc.):

Storage of volatile organic liquid

Manufacturer:	Model number:	Serial number:
Construction date: See Attachment D Equipment Table	Installation date: See Attachment D Equipment Table	Modification date(s): See Attachment D Equipment Table

Design Capacity (examples: furnaces - tons/hr, tanks - gallons): See Attachment D Equipment Table

Maximum Hourly Throughput:	Maximum Annual Throughput:	Maximum Operating Schedule: 24 hrs/day, 365 days/yr
-----------------------------------	-----------------------------------	---

Fuel Usage Data (fill out all applicable fields)

Does this emission unit combust fuel? ___ Yes <u> X </u> No	If yes, is it? ___ Indirect Fired ___ Direct Fired
Maximum design heat input and/or maximum horsepower rating:	Type and Btu/hr rating of burners:

List the primary fuel type(s) and if applicable, the secondary fuel type(s). For each fuel type listed, provide the maximum hourly and annual fuel usage for each.

Describe each fuel expected to be used during the term of the permit.

Fuel Type	Max. Sulfur Content	Max. Ash Content	BTU Value

Union Carbide Corporation South Charleston Facility – Chemical Mixing Plant

<i>Emissions Data</i>		
Criteria Pollutants	Potential Emissions	
	PPH	TPY
Carbon Monoxide (CO)		
Nitrogen Oxides (NO _x)		
Lead (Pb)		
Particulate Matter (PM _{2.5})		
Particulate Matter (PM ₁₀)		
Total Particulate Matter (TSP)		
Sulfur Dioxide (SO ₂)		
Volatile Organic Compounds (VOC)		
Hazardous Air Pollutants	Potential Emissions	
	PPH	TPY
Regulated Pollutants other than Criteria and HAP	Potential Emissions	
	PPH	TPY

List the method(s) used to calculate the potential emissions (include dates of any stack tests conducted, versions of software used, source and dates of emission factors, etc.).

Applicable Requirements

List all applicable requirements for this emission unit. For each applicable requirement, include the underlying rule/regulation citation and/or construction permit with the condition number. (Note: Title V permit condition numbers alone are not the underlying applicable requirements). If an emission limit is calculated based on the type of source and design capacity or if a standard is based on a design parameter, this information should also be included.

See Attachment I for applicable requirements, monitoring, recordkeeping, reporting and testing from existing Title V permit.

Permit Shield

For all applicable requirements listed above, provide monitoring/testing/recordkeeping/reporting which shall be used to demonstrate compliance. If the method is based on a permit or rule, include the condition number or citation. (Note: Each requirement listed above must have an associated method of demonstrating compliance. If there is not already a required method in place, then a method must be proposed.)

See Attachment I for applicable requirements, monitoring, recordkeeping, reporting and testing from existing Title V permit.

Are you in compliance with all applicable requirements for this emission unit? Yes No

If no, complete the **Schedule of Compliance Form** as ATTACHMENT F.

ATTACHMENT E - Emission Unit Form

Emission Unit Description: Storage Tank

Emission unit ID number: 2048	Emission unit name: Tank 2048	List any control devices associated with this emission unit:
---	---	---

Provide a description of the emission unit (type, method of operation, design parameters, etc.):

Storage of volatile organic liquid

Manufacturer:	Model number:	Serial number:
Construction date: See Attachment D Equipment Table	Installation date: See Attachment D Equipment Table	Modification date(s): See Attachment D Equipment Table

Design Capacity (examples: furnaces - tons/hr, tanks - gallons): See Attachment D Equipment Table

Maximum Hourly Throughput:	Maximum Annual Throughput:	Maximum Operating Schedule: 24 hrs/day, 365 days/yr
-----------------------------------	-----------------------------------	---

Fuel Usage Data (fill out all applicable fields)

Does this emission unit combust fuel? ___Yes <u>X</u> No	If yes, is it? ___ Indirect Fired ___ Direct Fired
Maximum design heat input and/or maximum horsepower rating:	Type and Btu/hr rating of burners:

List the primary fuel type(s) and if applicable, the secondary fuel type(s). For each fuel type listed, provide the maximum hourly and annual fuel usage for each.

Describe each fuel expected to be used during the term of the permit.

Fuel Type	Max. Sulfur Content	Max. Ash Content	BTU Value

Union Carbide Corporation South Charleston Facility – Chemical Mixing Plant

<i>Emissions Data</i>		
Criteria Pollutants	Potential Emissions	
	PPH	TPY
Carbon Monoxide (CO)		
Nitrogen Oxides (NO _x)		
Lead (Pb)		
Particulate Matter (PM _{2.5})		
Particulate Matter (PM ₁₀)		
Total Particulate Matter (TSP)		
Sulfur Dioxide (SO ₂)		
Volatile Organic Compounds (VOC)		
Hazardous Air Pollutants	Potential Emissions	
	PPH	TPY
Regulated Pollutants other than Criteria and HAP	Potential Emissions	
	PPH	TPY
<p>List the method(s) used to calculate the potential emissions (include dates of any stack tests conducted, versions of software used, source and dates of emission factors, etc.).</p>		

Applicable Requirements

List all applicable requirements for this emission unit. For each applicable requirement, include the underlying rule/regulation citation and/or construction permit with the condition number. (Note: Title V permit condition numbers alone are not the underlying applicable requirements). If an emission limit is calculated based on the type of source and design capacity or if a standard is based on a design parameter, this information should also be included.

See Attachment I for applicable requirements, monitoring, recordkeeping, reporting and testing from existing Title V permit.

Permit Shield

For all applicable requirements listed above, provide monitoring/testing/recordkeeping/reporting which shall be used to demonstrate compliance. If the method is based on a permit or rule, include the condition number or citation. (Note: Each requirement listed above must have an associated method of demonstrating compliance. If there is not already a required method in place, then a method must be proposed.)

See Attachment I for applicable requirements, monitoring, recordkeeping, reporting and testing from existing Title V permit.

Are you in compliance with all applicable requirements for this emission unit? Yes No

If no, complete the **Schedule of Compliance Form** as ATTACHMENT F.

ATTACHMENT E - Emission Unit Form

Emission Unit Description: Storage Tank

Emission unit ID number: 2049	Emission unit name: Tank 2049	List any control devices associated with this emission unit:
---	---	---

Provide a description of the emission unit (type, method of operation, design parameters, etc.):

Storage of volatile organic liquid

Manufacturer:	Model number:	Serial number:
Construction date: See Attachment D Equipment Table	Installation date: See Attachment D Equipment Table	Modification date(s): See Attachment D Equipment Table

Design Capacity (examples: furnaces - tons/hr, tanks - gallons): See Attachment D Equipment Table

Maximum Hourly Throughput:	Maximum Annual Throughput:	Maximum Operating Schedule: 24 hrs/day, 365 days/yr
-----------------------------------	-----------------------------------	---

Fuel Usage Data (fill out all applicable fields)

Does this emission unit combust fuel? ___ Yes <u> X </u> No	If yes, is it? ___ Indirect Fired ___ Direct Fired
Maximum design heat input and/or maximum horsepower rating:	Type and Btu/hr rating of burners:

List the primary fuel type(s) and if applicable, the secondary fuel type(s). For each fuel type listed, provide the maximum hourly and annual fuel usage for each.

Describe each fuel expected to be used during the term of the permit.

Fuel Type	Max. Sulfur Content	Max. Ash Content	BTU Value

Union Carbide Corporation South Charleston Facility – Chemical Mixing Plant

Emissions Data		
Criteria Pollutants	Potential Emissions	
	PPH	TPY
Carbon Monoxide (CO)		
Nitrogen Oxides (NO _x)		
Lead (Pb)		
Particulate Matter (PM _{2.5})		
Particulate Matter (PM ₁₀)		
Total Particulate Matter (TSP)		
Sulfur Dioxide (SO ₂)		
Volatile Organic Compounds (VOC)		
Hazardous Air Pollutants	Potential Emissions	
	PPH	TPY
Regulated Pollutants other than Criteria and HAP	Potential Emissions	
	PPH	TPY

List the method(s) used to calculate the potential emissions (include dates of any stack tests conducted, versions of software used, source and dates of emission factors, etc.).

Applicable Requirements

List all applicable requirements for this emission unit. For each applicable requirement, include the underlying rule/regulation citation and/or construction permit with the condition number. (Note: Title V permit condition numbers alone are not the underlying applicable requirements). If an emission limit is calculated based on the type of source and design capacity or if a standard is based on a design parameter, this information should also be included.

See Attachment I for applicable requirements, monitoring, recordkeeping, reporting and testing from existing Title V permit.

Permit Shield

For all applicable requirements listed above, provide monitoring/testing/recordkeeping/reporting which shall be used to demonstrate compliance. If the method is based on a permit or rule, include the condition number or citation. (Note: Each requirement listed above must have an associated method of demonstrating compliance. If there is not already a required method in place, then a method must be proposed.)

See Attachment I for applicable requirements, monitoring, recordkeeping, reporting and testing from existing Title V permit.

Are you in compliance with all applicable requirements for this emission unit? Yes No

If no, complete the **Schedule of Compliance Form** as ATTACHMENT F.

ATTACHMENT E - Emission Unit Form

Emission Unit Description: Storage Tank

Emission unit ID number: 2050	Emission unit name: Tank 2050	List any control devices associated with this emission unit:
---	---	---

Provide a description of the emission unit (type, method of operation, design parameters, etc.):

Storage of volatile organic liquid

Manufacturer:	Model number:	Serial number:
Construction date: See Attachment D Equipment Table	Installation date: See Attachment D Equipment Table	Modification date(s): See Attachment D Equipment Table

Design Capacity (examples: furnaces - tons/hr, tanks - gallons): See Attachment D Equipment Table

Maximum Hourly Throughput:	Maximum Annual Throughput:	Maximum Operating Schedule: 24 hrs/day, 365 days/yr
-----------------------------------	-----------------------------------	---

Fuel Usage Data (fill out all applicable fields)

Does this emission unit combust fuel? ___Yes <u>X</u> No	If yes, is it? ___ Indirect Fired ___ Direct Fired
Maximum design heat input and/or maximum horsepower rating:	Type and Btu/hr rating of burners:

List the primary fuel type(s) and if applicable, the secondary fuel type(s). For each fuel type listed, provide the maximum hourly and annual fuel usage for each.

Describe each fuel expected to be used during the term of the permit.

Fuel Type	Max. Sulfur Content	Max. Ash Content	BTU Value

Union Carbide Corporation South Charleston Facility – Chemical Mixing Plant

<i>Emissions Data</i>		
Criteria Pollutants	Potential Emissions	
	PPH	TPY
Carbon Monoxide (CO)		
Nitrogen Oxides (NO _x)		
Lead (Pb)		
Particulate Matter (PM _{2.5})		
Particulate Matter (PM ₁₀)		
Total Particulate Matter (TSP)		
Sulfur Dioxide (SO ₂)		
Volatile Organic Compounds (VOC)		
Hazardous Air Pollutants	Potential Emissions	
	PPH	TPY
Regulated Pollutants other than Criteria and HAP	Potential Emissions	
	PPH	TPY

List the method(s) used to calculate the potential emissions (include dates of any stack tests conducted, versions of software used, source and dates of emission factors, etc.).

Applicable Requirements

List all applicable requirements for this emission unit. For each applicable requirement, include the underlying rule/regulation citation and/or construction permit with the condition number. (Note: Title V permit condition numbers alone are not the underlying applicable requirements). If an emission limit is calculated based on the type of source and design capacity or if a standard is based on a design parameter, this information should also be included.

See Attachment I for applicable requirements, monitoring, recordkeeping, reporting and testing from existing Title V permit.

Permit Shield

For all applicable requirements listed above, provide monitoring/testing/recordkeeping/reporting which shall be used to demonstrate compliance. If the method is based on a permit or rule, include the condition number or citation. (Note: Each requirement listed above must have an associated method of demonstrating compliance. If there is not already a required method in place, then a method must be proposed.)

See Attachment I for applicable requirements, monitoring, recordkeeping, reporting and testing from existing Title V permit.

Are you in compliance with all applicable requirements for this emission unit? Yes No

If no, complete the **Schedule of Compliance Form** as ATTACHMENT F.

ATTACHMENT E - Emission Unit Form

Emission Unit Description: Storage Tank

Emission unit ID number: 2047	Emission unit name: Tank 2047	List any control devices associated with this emission unit:
---	---	---

Provide a description of the emission unit (type, method of operation, design parameters, etc.):

Storage of volatile organic liquid

Manufacturer:	Model number:	Serial number:
Construction date: See Attachment D Equipment Table	Installation date: See Attachment D Equipment Table	Modification date(s): See Attachment D Equipment Table

Design Capacity (examples: furnaces - tons/hr, tanks - gallons): See Attachment D Equipment Table

Maximum Hourly Throughput:	Maximum Annual Throughput:	Maximum Operating Schedule: 24 hrs/day, 365 days/yr
-----------------------------------	-----------------------------------	---

Fuel Usage Data (fill out all applicable fields)

Does this emission unit combust fuel? ___ Yes <u> X </u> No	If yes, is it? ___ Indirect Fired ___ Direct Fired
Maximum design heat input and/or maximum horsepower rating:	Type and Btu/hr rating of burners:

List the primary fuel type(s) and if applicable, the secondary fuel type(s). For each fuel type listed, provide the maximum hourly and annual fuel usage for each.

Describe each fuel expected to be used during the term of the permit.

Fuel Type	Max. Sulfur Content	Max. Ash Content	BTU Value

Union Carbide Corporation South Charleston Facility – Chemical Mixing Plant

<i>Emissions Data</i>		
Criteria Pollutants	Potential Emissions	
	PPH	TPY
Carbon Monoxide (CO)		
Nitrogen Oxides (NO _x)		
Lead (Pb)		
Particulate Matter (PM _{2.5})		
Particulate Matter (PM ₁₀)		
Total Particulate Matter (TSP)		
Sulfur Dioxide (SO ₂)		
Volatile Organic Compounds (VOC)		
Hazardous Air Pollutants	Potential Emissions	
	PPH	TPY
Regulated Pollutants other than Criteria and HAP	Potential Emissions	
	PPH	TPY

List the method(s) used to calculate the potential emissions (include dates of any stack tests conducted, versions of software used, source and dates of emission factors, etc.).

Applicable Requirements

List all applicable requirements for this emission unit. For each applicable requirement, include the underlying rule/regulation citation and/or construction permit with the condition number. (Note: Title V permit condition numbers alone are not the underlying applicable requirements). If an emission limit is calculated based on the type of source and design capacity or if a standard is based on a design parameter, this information should also be included.

See Attachment I for applicable requirements, monitoring, recordkeeping, reporting and testing from existing Title V permit.

X Permit Shield

For all applicable requirements listed above, provide monitoring/testing/recordkeeping/reporting which shall be used to demonstrate compliance. If the method is based on a permit or rule, include the condition number or citation. (Note: Each requirement listed above must have an associated method of demonstrating compliance. If there is not already a required method in place, then a method must be proposed.)

See Attachment I for applicable requirements, monitoring, recordkeeping, reporting and testing from existing Title V permit.

Are you in compliance with all applicable requirements for this emission unit? X Yes No

If no, complete the **Schedule of Compliance Form** as **ATTACHMENT F**.

ATTACHMENT E - Emission Unit Form

Emission Unit Description: Storage Tank

Emission unit ID number: 2046	Emission unit name: Tank 2046	List any control devices associated with this emission unit:
---	---	---

Provide a description of the emission unit (type, method of operation, design parameters, etc.):

Storage of volatile organic liquid

Manufacturer:	Model number:	Serial number:
Construction date: See Attachment D Equipment Table	Installation date: See Attachment D Equipment Table	Modification date(s): See Attachment D Equipment Table

Design Capacity (examples: furnaces - tons/hr, tanks - gallons): See Attachment D Equipment Table

Maximum Hourly Throughput:	Maximum Annual Throughput:	Maximum Operating Schedule: 24 hrs/day, 365 days/yr
-----------------------------------	-----------------------------------	---

Fuel Usage Data (fill out all applicable fields)

Does this emission unit combust fuel? ___ Yes <u> X </u> No	If yes, is it? ___ Indirect Fired ___ Direct Fired
Maximum design heat input and/or maximum horsepower rating:	Type and Btu/hr rating of burners:

List the primary fuel type(s) and if applicable, the secondary fuel type(s). For each fuel type listed, provide the maximum hourly and annual fuel usage for each.

Describe each fuel expected to be used during the term of the permit.

Fuel Type	Max. Sulfur Content	Max. Ash Content	BTU Value

Union Carbide Corporation South Charleston Facility – Chemical Mixing Plant

<i>Emissions Data</i>		
Criteria Pollutants	Potential Emissions	
	PPH	TPY
Carbon Monoxide (CO)		
Nitrogen Oxides (NO _x)		
Lead (Pb)		
Particulate Matter (PM _{2.5})		
Particulate Matter (PM ₁₀)		
Total Particulate Matter (TSP)		
Sulfur Dioxide (SO ₂)		
Volatile Organic Compounds (VOC)		
Hazardous Air Pollutants	Potential Emissions	
	PPH	TPY
Regulated Pollutants other than Criteria and HAP	Potential Emissions	
	PPH	TPY

List the method(s) used to calculate the potential emissions (include dates of any stack tests conducted, versions of software used, source and dates of emission factors, etc.).

Applicable Requirements

List all applicable requirements for this emission unit. For each applicable requirement, include the underlying rule/regulation citation and/or construction permit with the condition number. (Note: Title V permit condition numbers alone are not the underlying applicable requirements). If an emission limit is calculated based on the type of source and design capacity or if a standard is based on a design parameter, this information should also be included.

See Attachment I for applicable requirements, monitoring, recordkeeping, reporting and testing from existing Title V permit.

Permit Shield

For all applicable requirements listed above, provide monitoring/testing/recordkeeping/reporting which shall be used to demonstrate compliance. If the method is based on a permit or rule, include the condition number or citation. (Note: Each requirement listed above must have an associated method of demonstrating compliance. If there is not already a required method in place, then a method must be proposed.)

See Attachment I for applicable requirements, monitoring, recordkeeping, reporting and testing from existing Title V permit.

Are you in compliance with all applicable requirements for this emission unit? Yes No

If no, complete the **Schedule of Compliance Form** as ATTACHMENT F.

ATTACHMENT E - Emission Unit Form

Emission Unit Description: Storage Tank

Emission unit ID number: 2051A	Emission unit name: Tank 2051A	List any control devices associated with this emission unit:
--	--	---

Provide a description of the emission unit (type, method of operation, design parameters, etc.):

Storage of volatile organic liquid

Manufacturer:	Model number:	Serial number:
Construction date: See Attachment D Equipment Table	Installation date: See Attachment D Equipment Table	Modification date(s): See Attachment D Equipment Table

Design Capacity (examples: furnaces - tons/hr, tanks - gallons): See Attachment D Equipment Table

Maximum Hourly Throughput:	Maximum Annual Throughput:	Maximum Operating Schedule: 24 hrs/day, 365 days/yr
-----------------------------------	-----------------------------------	---

Fuel Usage Data (fill out all applicable fields)

Does this emission unit combust fuel? ___ Yes <u> X </u> No	If yes, is it? ___ Indirect Fired ___ Direct Fired
Maximum design heat input and/or maximum horsepower rating:	Type and Btu/hr rating of burners:

List the primary fuel type(s) and if applicable, the secondary fuel type(s). For each fuel type listed, provide the maximum hourly and annual fuel usage for each.

Describe each fuel expected to be used during the term of the permit.

Fuel Type	Max. Sulfur Content	Max. Ash Content	BTU Value

Union Carbide Corporation South Charleston Facility – Chemical Mixing Plant

<i>Emissions Data</i>		
Criteria Pollutants	Potential Emissions	
	PPH	TPY
Carbon Monoxide (CO)		
Nitrogen Oxides (NO _x)		
Lead (Pb)		
Particulate Matter (PM _{2.5})		
Particulate Matter (PM ₁₀)		
Total Particulate Matter (TSP)		
Sulfur Dioxide (SO ₂)		
Volatile Organic Compounds (VOC)		
Hazardous Air Pollutants	Potential Emissions	
	PPH	TPY
Regulated Pollutants other than Criteria and HAP	Potential Emissions	
	PPH	TPY

List the method(s) used to calculate the potential emissions (include dates of any stack tests conducted, versions of software used, source and dates of emission factors, etc.).

Applicable Requirements

List all applicable requirements for this emission unit. For each applicable requirement, include the underlying rule/regulation citation and/or construction permit with the condition number. (Note: Title V permit condition numbers alone are not the underlying applicable requirements). If an emission limit is calculated based on the type of source and design capacity or if a standard is based on a design parameter, this information should also be included.

See Attachment I for applicable requirements, monitoring, recordkeeping, reporting and testing from existing Title V permit.

Permit Shield

For all applicable requirements listed above, provide monitoring/testing/recordkeeping/reporting which shall be used to demonstrate compliance. If the method is based on a permit or rule, include the condition number or citation. (Note: Each requirement listed above must have an associated method of demonstrating compliance. If there is not already a required method in place, then a method must be proposed.)

See Attachment I for applicable requirements, monitoring, recordkeeping, reporting and testing from existing Title V permit.

Are you in compliance with all applicable requirements for this emission unit? Yes No

If no, complete the **Schedule of Compliance Form** as ATTACHMENT F.

ATTACHMENT E - Emission Unit Form

Emission Unit Description: Storage Tank

Emission unit ID number: 2052	Emission unit name: Tank 2052	List any control devices associated with this emission unit:
---	---	---

Provide a description of the emission unit (type, method of operation, design parameters, etc.):

Storage of volatile organic liquid

Manufacturer:	Model number:	Serial number:
Construction date: See Attachment D Equipment Table	Installation date: See Attachment D Equipment Table	Modification date(s): See Attachment D Equipment Table

Design Capacity (examples: furnaces - tons/hr, tanks - gallons): See Attachment D Equipment Table

Maximum Hourly Throughput:	Maximum Annual Throughput:	Maximum Operating Schedule: 24 hrs/day, 365 days/yr
-----------------------------------	-----------------------------------	---

Fuel Usage Data (fill out all applicable fields)

Does this emission unit combust fuel? ___ Yes <u> X </u> No	If yes, is it? ___ Indirect Fired ___ Direct Fired
Maximum design heat input and/or maximum horsepower rating:	Type and Btu/hr rating of burners:

List the primary fuel type(s) and if applicable, the secondary fuel type(s). For each fuel type listed, provide the maximum hourly and annual fuel usage for each.

Describe each fuel expected to be used during the term of the permit.

Fuel Type	Max. Sulfur Content	Max. Ash Content	BTU Value

Union Carbide Corporation South Charleston Facility – Chemical Mixing Plant

Emissions Data		
Criteria Pollutants	Potential Emissions	
	PPH	TPY
Carbon Monoxide (CO)		
Nitrogen Oxides (NO _x)		
Lead (Pb)		
Particulate Matter (PM _{2.5})		
Particulate Matter (PM ₁₀)		
Total Particulate Matter (TSP)		
Sulfur Dioxide (SO ₂)		
Volatile Organic Compounds (VOC)		
Hazardous Air Pollutants	Potential Emissions	
	PPH	TPY
Regulated Pollutants other than Criteria and HAP	Potential Emissions	
	PPH	TPY

List the method(s) used to calculate the potential emissions (include dates of any stack tests conducted, versions of software used, source and dates of emission factors, etc.).

Applicable Requirements

List all applicable requirements for this emission unit. For each applicable requirement, include the underlying rule/regulation citation and/or construction permit with the condition number. (Note: Title V permit condition numbers alone are not the underlying applicable requirements). If an emission limit is calculated based on the type of source and design capacity or if a standard is based on a design parameter, this information should also be included.

See Attachment I for applicable requirements, monitoring, recordkeeping, reporting and testing from existing Title V permit.

Permit Shield

For all applicable requirements listed above, provide monitoring/testing/recordkeeping/reporting which shall be used to demonstrate compliance. If the method is based on a permit or rule, include the condition number or citation. (Note: Each requirement listed above must have an associated method of demonstrating compliance. If there is not already a required method in place, then a method must be proposed.)

See Attachment I for applicable requirements, monitoring, recordkeeping, reporting and testing from existing Title V permit.

Are you in compliance with all applicable requirements for this emission unit? Yes No

If no, complete the **Schedule of Compliance Form** as ATTACHMENT F.

ATTACHMENT E - Emission Unit Form

Emission Unit Description: Storage Tank

Emission unit ID number: 2053	Emission unit name: Tank 2053	List any control devices associated with this emission unit:
---	---	---

Provide a description of the emission unit (type, method of operation, design parameters, etc.):

Storage of volatile organic liquid

Manufacturer:	Model number:	Serial number:
Construction date: See Attachment D Equipment Table	Installation date: See Attachment D Equipment Table	Modification date(s): See Attachment D Equipment Table

Design Capacity (examples: furnaces - tons/hr, tanks - gallons): See Attachment D Equipment Table

Maximum Hourly Throughput:	Maximum Annual Throughput:	Maximum Operating Schedule: 24 hrs/day, 365 days/yr
-----------------------------------	-----------------------------------	---

Fuel Usage Data (fill out all applicable fields)

Does this emission unit combust fuel? ___ Yes <u> X </u> No	If yes, is it? ___ Indirect Fired ___ Direct Fired
Maximum design heat input and/or maximum horsepower rating:	Type and Btu/hr rating of burners:

List the primary fuel type(s) and if applicable, the secondary fuel type(s). For each fuel type listed, provide the maximum hourly and annual fuel usage for each.

Describe each fuel expected to be used during the term of the permit.

Fuel Type	Max. Sulfur Content	Max. Ash Content	BTU Value

Union Carbide Corporation South Charleston Facility – Chemical Mixing Plant

Emissions Data		
Criteria Pollutants	Potential Emissions	
	PPH	TPY
Carbon Monoxide (CO)		
Nitrogen Oxides (NO _x)		
Lead (Pb)		
Particulate Matter (PM _{2.5})		
Particulate Matter (PM ₁₀)		
Total Particulate Matter (TSP)		
Sulfur Dioxide (SO ₂)		
Volatile Organic Compounds (VOC)		
Hazardous Air Pollutants	Potential Emissions	
	PPH	TPY
Regulated Pollutants other than Criteria and HAP	Potential Emissions	
	PPH	TPY

List the method(s) used to calculate the potential emissions (include dates of any stack tests conducted, versions of software used, source and dates of emission factors, etc.).

Applicable Requirements

List all applicable requirements for this emission unit. For each applicable requirement, include the underlying rule/regulation citation and/or construction permit with the condition number. (Note: Title V permit condition numbers alone are not the underlying applicable requirements). If an emission limit is calculated based on the type of source and design capacity or if a standard is based on a design parameter, this information should also be included.

See Attachment I for applicable requirements, monitoring, recordkeeping, reporting and testing from existing Title V permit.

 X Permit Shield

For all applicable requirements listed above, provide monitoring/testing/recordkeeping/reporting which shall be used to demonstrate compliance. If the method is based on a permit or rule, include the condition number or citation. (Note: Each requirement listed above must have an associated method of demonstrating compliance. If there is not already a required method in place, then a method must be proposed.)

See Attachment I for applicable requirements, monitoring, recordkeeping, reporting and testing from existing Title V permit.

Are you in compliance with all applicable requirements for this emission unit? X Yes No

If no, complete the **Schedule of Compliance Form** as **ATTACHMENT F**.

ATTACHMENT E - Emission Unit Form

Emission Unit Description: Storage Tank

Emission unit ID number: 2055	Emission unit name: Tank 2055	List any control devices associated with this emission unit:
---	---	---

Provide a description of the emission unit (type, method of operation, design parameters, etc.):

Storage of volatile organic liquid

Manufacturer:	Model number:	Serial number:
Construction date: See Attachment D Equipment Table	Installation date: See Attachment D Equipment Table	Modification date(s): See Attachment D Equipment Table

Design Capacity (examples: furnaces - tons/hr, tanks - gallons): See Attachment D Equipment Table

Maximum Hourly Throughput:	Maximum Annual Throughput:	Maximum Operating Schedule: 24 hrs/day, 365 days/yr
-----------------------------------	-----------------------------------	---

Fuel Usage Data (fill out all applicable fields)

Does this emission unit combust fuel? ___Yes <u>X</u> No	If yes, is it? ___ Indirect Fired ___ Direct Fired
Maximum design heat input and/or maximum horsepower rating:	Type and Btu/hr rating of burners:

List the primary fuel type(s) and if applicable, the secondary fuel type(s). For each fuel type listed, provide the maximum hourly and annual fuel usage for each.

Describe each fuel expected to be used during the term of the permit.

Fuel Type	Max. Sulfur Content	Max. Ash Content	BTU Value

Union Carbide Corporation South Charleston Facility – Chemical Mixing Plant

<i>Emissions Data</i>		
Criteria Pollutants	Potential Emissions	
	PPH	TPY
Carbon Monoxide (CO)		
Nitrogen Oxides (NO _x)		
Lead (Pb)		
Particulate Matter (PM _{2.5})		
Particulate Matter (PM ₁₀)		
Total Particulate Matter (TSP)		
Sulfur Dioxide (SO ₂)		
Volatile Organic Compounds (VOC)		
Hazardous Air Pollutants	Potential Emissions	
	PPH	TPY
Regulated Pollutants other than Criteria and HAP	Potential Emissions	
	PPH	TPY

List the method(s) used to calculate the potential emissions (include dates of any stack tests conducted, versions of software used, source and dates of emission factors, etc.).

Applicable Requirements

List all applicable requirements for this emission unit. For each applicable requirement, include the underlying rule/regulation citation and/or construction permit with the condition number. (Note: Title V permit condition numbers alone are not the underlying applicable requirements). If an emission limit is calculated based on the type of source and design capacity or if a standard is based on a design parameter, this information should also be included.

See Attachment I for applicable requirements, monitoring, recordkeeping, reporting and testing from existing Title V permit.

X Permit Shield

For all applicable requirements listed above, provide monitoring/testing/recordkeeping/reporting which shall be used to demonstrate compliance. If the method is based on a permit or rule, include the condition number or citation. (Note: Each requirement listed above must have an associated method of demonstrating compliance. If there is not already a required method in place, then a method must be proposed.)

See Attachment I for applicable requirements, monitoring, recordkeeping, reporting and testing from existing Title V permit.

Are you in compliance with all applicable requirements for this emission unit? X Yes No

If no, complete the **Schedule of Compliance Form** as **ATTACHMENT F**.

ATTACHMENT E - Emission Unit Form

Emission Unit Description: Storage Tank

Emission unit ID number: 2051B	Emission unit name: Tank 2051B	List any control devices associated with this emission unit:
--	--	---

Provide a description of the emission unit (type, method of operation, design parameters, etc.):

Storage of volatile organic liquid

Manufacturer:	Model number:	Serial number:
Construction date: See Attachment D Equipment Table	Installation date: See Attachment D Equipment Table	Modification date(s): See Attachment D Equipment Table

Design Capacity (examples: furnaces - tons/hr, tanks - gallons): See Attachment D Equipment Table

Maximum Hourly Throughput:	Maximum Annual Throughput:	Maximum Operating Schedule: 24 hrs/day, 365 days/yr
-----------------------------------	-----------------------------------	---

Fuel Usage Data (fill out all applicable fields)

Does this emission unit combust fuel? ___Yes <u>X</u> No	If yes, is it? ___ Indirect Fired ___ Direct Fired
Maximum design heat input and/or maximum horsepower rating:	Type and Btu/hr rating of burners:

List the primary fuel type(s) and if applicable, the secondary fuel type(s). For each fuel type listed, provide the maximum hourly and annual fuel usage for each.

Describe each fuel expected to be used during the term of the permit.

Fuel Type	Max. Sulfur Content	Max. Ash Content	BTU Value

Union Carbide Corporation South Charleston Facility – Chemical Mixing Plant

<i>Emissions Data</i>		
Criteria Pollutants	Potential Emissions	
	PPH	TPY
Carbon Monoxide (CO)		
Nitrogen Oxides (NO _x)		
Lead (Pb)		
Particulate Matter (PM _{2.5})		
Particulate Matter (PM ₁₀)		
Total Particulate Matter (TSP)		
Sulfur Dioxide (SO ₂)		
Volatile Organic Compounds (VOC)		
Hazardous Air Pollutants	Potential Emissions	
	PPH	TPY
Regulated Pollutants other than Criteria and HAP	Potential Emissions	
	PPH	TPY

List the method(s) used to calculate the potential emissions (include dates of any stack tests conducted, versions of software used, source and dates of emission factors, etc.).

Applicable Requirements

List all applicable requirements for this emission unit. For each applicable requirement, include the underlying rule/regulation citation and/or construction permit with the condition number. (Note: Title V permit condition numbers alone are not the underlying applicable requirements). If an emission limit is calculated based on the type of source and design capacity or if a standard is based on a design parameter, this information should also be included.

See Attachment I for applicable requirements, monitoring, recordkeeping, reporting and testing from existing Title V permit.

X Permit Shield

For all applicable requirements listed above, provide monitoring/testing/recordkeeping/reporting which shall be used to demonstrate compliance. If the method is based on a permit or rule, include the condition number or citation. (Note: Each requirement listed above must have an associated method of demonstrating compliance. If there is not already a required method in place, then a method must be proposed.)

See Attachment I for applicable requirements, monitoring, recordkeeping, reporting and testing from existing Title V permit.

Are you in compliance with all applicable requirements for this emission unit? X Yes No

If no, complete the **Schedule of Compliance Form** as **ATTACHMENT F**.

ATTACHMENT E - Emission Unit Form

Emission Unit Description: Storage Tank

Emission unit ID number: 2054	Emission unit name: Tank 2054	List any control devices associated with this emission unit:
---	---	---

Provide a description of the emission unit (type, method of operation, design parameters, etc.):

Storage of volatile organic liquid

Manufacturer:	Model number:	Serial number:
Construction date: See Attachment D Equipment Table	Installation date: See Attachment D Equipment Table	Modification date(s): See Attachment D Equipment Table

Design Capacity (examples: furnaces - tons/hr, tanks - gallons): See Attachment D Equipment Table

Maximum Hourly Throughput:	Maximum Annual Throughput:	Maximum Operating Schedule: 24 hrs/day, 365 days/yr
-----------------------------------	-----------------------------------	---

Fuel Usage Data (fill out all applicable fields)

Does this emission unit combust fuel? ___ Yes <u> X </u> No	If yes, is it? ___ Indirect Fired ___ Direct Fired
Maximum design heat input and/or maximum horsepower rating:	Type and Btu/hr rating of burners:

List the primary fuel type(s) and if applicable, the secondary fuel type(s). For each fuel type listed, provide the maximum hourly and annual fuel usage for each.

Describe each fuel expected to be used during the term of the permit.

Fuel Type	Max. Sulfur Content	Max. Ash Content	BTU Value

Union Carbide Corporation South Charleston Facility – Chemical Mixing Plant

<i>Emissions Data</i>		
Criteria Pollutants	Potential Emissions	
	PPH	TPY
Carbon Monoxide (CO)		
Nitrogen Oxides (NO _x)		
Lead (Pb)		
Particulate Matter (PM _{2.5})		
Particulate Matter (PM ₁₀)		
Total Particulate Matter (TSP)		
Sulfur Dioxide (SO ₂)		
Volatile Organic Compounds (VOC)		
Hazardous Air Pollutants	Potential Emissions	
	PPH	TPY
Regulated Pollutants other than Criteria and HAP	Potential Emissions	
	PPH	TPY

List the method(s) used to calculate the potential emissions (include dates of any stack tests conducted, versions of software used, source and dates of emission factors, etc.).

Applicable Requirements

List all applicable requirements for this emission unit. For each applicable requirement, include the underlying rule/regulation citation and/or construction permit with the condition number. (Note: Title V permit condition numbers alone are not the underlying applicable requirements). If an emission limit is calculated based on the type of source and design capacity or if a standard is based on a design parameter, this information should also be included.

See Attachment I for applicable requirements, monitoring, recordkeeping, reporting and testing from existing Title V permit.

Permit Shield

For all applicable requirements listed above, provide monitoring/testing/recordkeeping/reporting which shall be used to demonstrate compliance. If the method is based on a permit or rule, include the condition number or citation. (Note: Each requirement listed above must have an associated method of demonstrating compliance. If there is not already a required method in place, then a method must be proposed.)

See Attachment I for applicable requirements, monitoring, recordkeeping, reporting and testing from existing Title V permit.

Are you in compliance with all applicable requirements for this emission unit? Yes No

If no, complete the **Schedule of Compliance Form** as ATTACHMENT F.

ATTACHMENT E - Emission Unit Form

Emission Unit Description: Storage Tank

Emission unit ID number: 2058	Emission unit name: Tank 2058	List any control devices associated with this emission unit:
---	---	---

Provide a description of the emission unit (type, method of operation, design parameters, etc.):

Storage of volatile organic liquid

Manufacturer:	Model number:	Serial number:
Construction date: See Attachment D Equipment Table	Installation date: See Attachment D Equipment Table	Modification date(s): See Attachment D Equipment Table

Design Capacity (examples: furnaces - tons/hr, tanks - gallons): See Attachment D Equipment Table

Maximum Hourly Throughput:	Maximum Annual Throughput:	Maximum Operating Schedule: 24 hrs/day, 365 days/yr
-----------------------------------	-----------------------------------	---

Fuel Usage Data (fill out all applicable fields)

Does this emission unit combust fuel? ___ Yes <u> X </u> No	If yes, is it? ___ Indirect Fired ___ Direct Fired
Maximum design heat input and/or maximum horsepower rating:	Type and Btu/hr rating of burners:

List the primary fuel type(s) and if applicable, the secondary fuel type(s). For each fuel type listed, provide the maximum hourly and annual fuel usage for each.

Describe each fuel expected to be used during the term of the permit.

Fuel Type	Max. Sulfur Content	Max. Ash Content	BTU Value

Union Carbide Corporation South Charleston Facility – Chemical Mixing Plant

<i>Emissions Data</i>		
Criteria Pollutants	Potential Emissions	
	PPH	TPY
Carbon Monoxide (CO)		
Nitrogen Oxides (NO _x)		
Lead (Pb)		
Particulate Matter (PM _{2.5})		
Particulate Matter (PM ₁₀)		
Total Particulate Matter (TSP)		
Sulfur Dioxide (SO ₂)		
Volatile Organic Compounds (VOC)		
Hazardous Air Pollutants	Potential Emissions	
	PPH	TPY
Regulated Pollutants other than Criteria and HAP	Potential Emissions	
	PPH	TPY

List the method(s) used to calculate the potential emissions (include dates of any stack tests conducted, versions of software used, source and dates of emission factors, etc.).

Applicable Requirements

List all applicable requirements for this emission unit. For each applicable requirement, include the underlying rule/regulation citation and/or construction permit with the condition number. (Note: Title V permit condition numbers alone are not the underlying applicable requirements). If an emission limit is calculated based on the type of source and design capacity or if a standard is based on a design parameter, this information should also be included.

See Attachment I for applicable requirements, monitoring, recordkeeping, reporting and testing from existing Title V permit.

Permit Shield

For all applicable requirements listed above, provide monitoring/testing/recordkeeping/reporting which shall be used to demonstrate compliance. If the method is based on a permit or rule, include the condition number or citation. (Note: Each requirement listed above must have an associated method of demonstrating compliance. If there is not already a required method in place, then a method must be proposed.)

See Attachment I for applicable requirements, monitoring, recordkeeping, reporting and testing from existing Title V permit.

Are you in compliance with all applicable requirements for this emission unit? Yes No

If no, complete the **Schedule of Compliance Form** as ATTACHMENT F.

ATTACHMENT E - Emission Unit Form

Emission Unit Description: Storage Tank

Emission unit ID number: 2059	Emission unit name: Tank 2059	List any control devices associated with this emission unit:
---	---	---

Provide a description of the emission unit (type, method of operation, design parameters, etc.):

Storage of volatile organic liquid

Manufacturer:	Model number:	Serial number:
Construction date: See Attachment D Equipment Table	Installation date: See Attachment D Equipment Table	Modification date(s): See Attachment D Equipment Table

Design Capacity (examples: furnaces - tons/hr, tanks - gallons): See Attachment D Equipment Table

Maximum Hourly Throughput:	Maximum Annual Throughput:	Maximum Operating Schedule: 24 hrs/day, 365 days/yr
-----------------------------------	-----------------------------------	---

Fuel Usage Data (fill out all applicable fields)

Does this emission unit combust fuel? ___ Yes <u> X </u> No	If yes, is it? ___ Indirect Fired ___ Direct Fired
Maximum design heat input and/or maximum horsepower rating:	Type and Btu/hr rating of burners:

List the primary fuel type(s) and if applicable, the secondary fuel type(s). For each fuel type listed, provide the maximum hourly and annual fuel usage for each.

Describe each fuel expected to be used during the term of the permit.

Fuel Type	Max. Sulfur Content	Max. Ash Content	BTU Value

Union Carbide Corporation South Charleston Facility – Chemical Mixing Plant

<i>Emissions Data</i>		
Criteria Pollutants	Potential Emissions	
	PPH	TPY
Carbon Monoxide (CO)		
Nitrogen Oxides (NO _x)		
Lead (Pb)		
Particulate Matter (PM _{2.5})		
Particulate Matter (PM ₁₀)		
Total Particulate Matter (TSP)		
Sulfur Dioxide (SO ₂)		
Volatile Organic Compounds (VOC)		
Hazardous Air Pollutants	Potential Emissions	
	PPH	TPY
Regulated Pollutants other than Criteria and HAP	Potential Emissions	
	PPH	TPY

List the method(s) used to calculate the potential emissions (include dates of any stack tests conducted, versions of software used, source and dates of emission factors, etc.).

Applicable Requirements

List all applicable requirements for this emission unit. For each applicable requirement, include the underlying rule/regulation citation and/or construction permit with the condition number. (Note: Title V permit condition numbers alone are not the underlying applicable requirements). If an emission limit is calculated based on the type of source and design capacity or if a standard is based on a design parameter, this information should also be included.

See Attachment I for applicable requirements, monitoring, recordkeeping, reporting and testing from existing Title V permit.

Permit Shield

For all applicable requirements listed above, provide monitoring/testing/recordkeeping/reporting which shall be used to demonstrate compliance. If the method is based on a permit or rule, include the condition number or citation. (Note: Each requirement listed above must have an associated method of demonstrating compliance. If there is not already a required method in place, then a method must be proposed.)

See Attachment I for applicable requirements, monitoring, recordkeeping, reporting and testing from existing Title V permit.

Are you in compliance with all applicable requirements for this emission unit? Yes No

If no, complete the **Schedule of Compliance Form** as ATTACHMENT F.

ATTACHMENT E - Emission Unit Form

Emission Unit Description: Storage Tank

Emission unit ID number: 2057	Emission unit name: Tank 2057	List any control devices associated with this emission unit:
---	---	---

Provide a description of the emission unit (type, method of operation, design parameters, etc.):
Storage of volatile organic liquid

Manufacturer:	Model number:	Serial number:
----------------------	----------------------	-----------------------

Construction date: See Attachment D Equipment Table	Installation date: See Attachment D Equipment Table	Modification date(s): See Attachment D Equipment Table
---	---	--

Design Capacity (examples: furnaces - tons/hr, tanks - gallons): See Attachment D Equipment Table

Maximum Hourly Throughput:	Maximum Annual Throughput:	Maximum Operating Schedule: 24 hrs/day, 365 days/yr
-----------------------------------	-----------------------------------	---

Fuel Usage Data (fill out all applicable fields)

Does this emission unit combust fuel? ___ Yes <u> X </u> No	If yes, is it? ___ Indirect Fired ___ Direct Fired
--	--

Maximum design heat input and/or maximum horsepower rating:	Type and Btu/hr rating of burners:
--	---

List the primary fuel type(s) and if applicable, the secondary fuel type(s). For each fuel type listed, provide the maximum hourly and annual fuel usage for each.

Describe each fuel expected to be used during the term of the permit.

Fuel Type	Max. Sulfur Content	Max. Ash Content	BTU Value

Union Carbide Corporation South Charleston Facility – Chemical Mixing Plant

<i>Emissions Data</i>		
Criteria Pollutants	Potential Emissions	
	PPH	TPY
Carbon Monoxide (CO)		
Nitrogen Oxides (NO _x)		
Lead (Pb)		
Particulate Matter (PM _{2.5})		
Particulate Matter (PM ₁₀)		
Total Particulate Matter (TSP)		
Sulfur Dioxide (SO ₂)		
Volatile Organic Compounds (VOC)		
Hazardous Air Pollutants	Potential Emissions	
	PPH	TPY
Regulated Pollutants other than Criteria and HAP	Potential Emissions	
	PPH	TPY

List the method(s) used to calculate the potential emissions (include dates of any stack tests conducted, versions of software used, source and dates of emission factors, etc.).

Applicable Requirements

List all applicable requirements for this emission unit. For each applicable requirement, include the underlying rule/regulation citation and/or construction permit with the condition number. (Note: Title V permit condition numbers alone are not the underlying applicable requirements). If an emission limit is calculated based on the type of source and design capacity or if a standard is based on a design parameter, this information should also be included.

See Attachment I for applicable requirements, monitoring, recordkeeping, reporting and testing from existing Title V permit.

X Permit Shield

For all applicable requirements listed above, provide monitoring/testing/recordkeeping/reporting which shall be used to demonstrate compliance. If the method is based on a permit or rule, include the condition number or citation. (Note: Each requirement listed above must have an associated method of demonstrating compliance. If there is not already a required method in place, then a method must be proposed.)

See Attachment I for applicable requirements, monitoring, recordkeeping, reporting and testing from existing Title V permit.

Are you in compliance with all applicable requirements for this emission unit? X Yes No

If no, complete the **Schedule of Compliance Form** as **ATTACHMENT F**.

ATTACHMENT E - Emission Unit Form

Emission Unit Description: Storage Tank

Emission unit ID number: 2056	Emission unit name: Tank 2056	List any control devices associated with this emission unit:
---	---	---

Provide a description of the emission unit (type, method of operation, design parameters, etc.):

Storage of volatile organic liquid

Manufacturer:	Model number:	Serial number:
Construction date: See Attachment D Equipment Table	Installation date: See Attachment D Equipment Table	Modification date(s): See Attachment D Equipment Table

Design Capacity (examples: furnaces - tons/hr, tanks - gallons): See Attachment D Equipment Table

Maximum Hourly Throughput:	Maximum Annual Throughput:	Maximum Operating Schedule: 24 hrs/day, 365 days/yr
-----------------------------------	-----------------------------------	---

Fuel Usage Data (fill out all applicable fields)

Does this emission unit combust fuel? ___ Yes <u> X </u> No	If yes, is it? ___ Indirect Fired ___ Direct Fired
Maximum design heat input and/or maximum horsepower rating:	Type and Btu/hr rating of burners:

List the primary fuel type(s) and if applicable, the secondary fuel type(s). For each fuel type listed, provide the maximum hourly and annual fuel usage for each.

Describe each fuel expected to be used during the term of the permit.

Fuel Type	Max. Sulfur Content	Max. Ash Content	BTU Value

Union Carbide Corporation South Charleston Facility – Chemical Mixing Plant

<i>Emissions Data</i>		
Criteria Pollutants	Potential Emissions	
	PPH	TPY
Carbon Monoxide (CO)		
Nitrogen Oxides (NO _x)		
Lead (Pb)		
Particulate Matter (PM _{2.5})		
Particulate Matter (PM ₁₀)		
Total Particulate Matter (TSP)		
Sulfur Dioxide (SO ₂)		
Volatile Organic Compounds (VOC)		
Hazardous Air Pollutants	Potential Emissions	
	PPH	TPY
Regulated Pollutants other than Criteria and HAP	Potential Emissions	
	PPH	TPY

List the method(s) used to calculate the potential emissions (include dates of any stack tests conducted, versions of software used, source and dates of emission factors, etc.).

Applicable Requirements

List all applicable requirements for this emission unit. For each applicable requirement, include the underlying rule/regulation citation and/or construction permit with the condition number. (Note: Title V permit condition numbers alone are not the underlying applicable requirements). If an emission limit is calculated based on the type of source and design capacity or if a standard is based on a design parameter, this information should also be included.

See Attachment I for applicable requirements, monitoring, recordkeeping, reporting and testing from existing Title V permit.

Permit Shield

For all applicable requirements listed above, provide monitoring/testing/recordkeeping/reporting which shall be used to demonstrate compliance. If the method is based on a permit or rule, include the condition number or citation. (Note: Each requirement listed above must have an associated method of demonstrating compliance. If there is not already a required method in place, then a method must be proposed.)

See Attachment I for applicable requirements, monitoring, recordkeeping, reporting and testing from existing Title V permit.

Are you in compliance with all applicable requirements for this emission unit? Yes No

If no, complete the **Schedule of Compliance Form** as ATTACHMENT F.

ATTACHMENT E - Emission Unit Form

Emission Unit Description: Storage Tank

Emission unit ID number: 2060	Emission unit name: Tank 2060	List any control devices associated with this emission unit:
---	---	---

Provide a description of the emission unit (type, method of operation, design parameters, etc.):

Storage of volatile organic liquid

Manufacturer:	Model number:	Serial number:
Construction date: See Attachment D Equipment Table	Installation date: See Attachment D Equipment Table	Modification date(s): See Attachment D Equipment Table

Design Capacity (examples: furnaces - tons/hr, tanks - gallons): See Attachment D Equipment Table

Maximum Hourly Throughput:	Maximum Annual Throughput:	Maximum Operating Schedule: 24 hrs/day, 365 days/yr
-----------------------------------	-----------------------------------	---

Fuel Usage Data (fill out all applicable fields)

Does this emission unit combust fuel? ___ Yes <input checked="" type="checkbox"/> No	If yes, is it? ___ Indirect Fired ___ Direct Fired
Maximum design heat input and/or maximum horsepower rating:	Type and Btu/hr rating of burners:

List the primary fuel type(s) and if applicable, the secondary fuel type(s). For each fuel type listed, provide the maximum hourly and annual fuel usage for each.

Describe each fuel expected to be used during the term of the permit.

Fuel Type	Max. Sulfur Content	Max. Ash Content	BTU Value

Union Carbide Corporation South Charleston Facility – Chemical Mixing Plant

<i>Emissions Data</i>		
Criteria Pollutants	Potential Emissions	
	PPH	TPY
Carbon Monoxide (CO)		
Nitrogen Oxides (NO _x)		
Lead (Pb)		
Particulate Matter (PM _{2.5})		
Particulate Matter (PM ₁₀)		
Total Particulate Matter (TSP)		
Sulfur Dioxide (SO ₂)		
Volatile Organic Compounds (VOC)		
Hazardous Air Pollutants	Potential Emissions	
	PPH	TPY
Regulated Pollutants other than Criteria and HAP	Potential Emissions	
	PPH	TPY

List the method(s) used to calculate the potential emissions (include dates of any stack tests conducted, versions of software used, source and dates of emission factors, etc.).

Applicable Requirements

List all applicable requirements for this emission unit. For each applicable requirement, include the underlying rule/regulation citation and/or construction permit with the condition number. (Note: Title V permit condition numbers alone are not the underlying applicable requirements). If an emission limit is calculated based on the type of source and design capacity or if a standard is based on a design parameter, this information should also be included.

See Attachment I for applicable requirements, monitoring, recordkeeping, reporting and testing from existing Title V permit.

Permit Shield

For all applicable requirements listed above, provide monitoring/testing/recordkeeping/reporting which shall be used to demonstrate compliance. If the method is based on a permit or rule, include the condition number or citation. (Note: Each requirement listed above must have an associated method of demonstrating compliance. If there is not already a required method in place, then a method must be proposed.)

See Attachment I for applicable requirements, monitoring, recordkeeping, reporting and testing from existing Title V permit.

Are you in compliance with all applicable requirements for this emission unit? Yes No

If no, complete the **Schedule of Compliance Form** as ATTACHMENT F.

ATTACHMENT E - Emission Unit Form

Emission Unit Description: Storage Tank

Emission unit ID number: 2064	Emission unit name: Tank 2064	List any control devices associated with this emission unit:
---	---	---

Provide a description of the emission unit (type, method of operation, design parameters, etc.):

Storage of volatile organic liquid

Manufacturer:	Model number:	Serial number:
Construction date: See Attachment D Equipment Table	Installation date: See Attachment D Equipment Table	Modification date(s): See Attachment D Equipment Table

Design Capacity (examples: furnaces - tons/hr, tanks - gallons): See Attachment D Equipment Table

Maximum Hourly Throughput:	Maximum Annual Throughput:	Maximum Operating Schedule: 24 hrs/day, 365 days/yr
-----------------------------------	-----------------------------------	---

Fuel Usage Data (fill out all applicable fields)

Does this emission unit combust fuel? ___Yes <u>X</u> No	If yes, is it? ___ Indirect Fired ___ Direct Fired
Maximum design heat input and/or maximum horsepower rating:	Type and Btu/hr rating of burners:

List the primary fuel type(s) and if applicable, the secondary fuel type(s). For each fuel type listed, provide the maximum hourly and annual fuel usage for each.

Describe each fuel expected to be used during the term of the permit.

Fuel Type	Max. Sulfur Content	Max. Ash Content	BTU Value

Union Carbide Corporation South Charleston Facility – Chemical Mixing Plant

<i>Emissions Data</i>		
Criteria Pollutants	Potential Emissions	
	PPH	TPY
Carbon Monoxide (CO)		
Nitrogen Oxides (NO _x)		
Lead (Pb)		
Particulate Matter (PM _{2.5})		
Particulate Matter (PM ₁₀)		
Total Particulate Matter (TSP)		
Sulfur Dioxide (SO ₂)		
Volatile Organic Compounds (VOC)		
Hazardous Air Pollutants	Potential Emissions	
	PPH	TPY
Regulated Pollutants other than Criteria and HAP	Potential Emissions	
	PPH	TPY

List the method(s) used to calculate the potential emissions (include dates of any stack tests conducted, versions of software used, source and dates of emission factors, etc.).

Applicable Requirements

List all applicable requirements for this emission unit. For each applicable requirement, include the underlying rule/regulation citation and/or construction permit with the condition number. (Note: Title V permit condition numbers alone are not the underlying applicable requirements). If an emission limit is calculated based on the type of source and design capacity or if a standard is based on a design parameter, this information should also be included.

See Attachment I for applicable requirements, monitoring, recordkeeping, reporting and testing from existing Title V permit.

X Permit Shield

For all applicable requirements listed above, provide monitoring/testing/recordkeeping/reporting which shall be used to demonstrate compliance. If the method is based on a permit or rule, include the condition number or citation. (Note: Each requirement listed above must have an associated method of demonstrating compliance. If there is not already a required method in place, then a method must be proposed.)

See Attachment I for applicable requirements, monitoring, recordkeeping, reporting and testing from existing Title V permit.

Are you in compliance with all applicable requirements for this emission unit? X Yes No

If no, complete the **Schedule of Compliance Form** as ATTACHMENT F.

ATTACHMENT E - Emission Unit Form

Emission Unit Description: Storage Tank

Emission unit ID number: 2063	Emission unit name: Tank 2063	List any control devices associated with this emission unit:
---	---	---

Provide a description of the emission unit (type, method of operation, design parameters, etc.):

Storage of volatile organic liquid

Manufacturer:	Model number:	Serial number:
Construction date: See Attachment D Equipment Table	Installation date: See Attachment D Equipment Table	Modification date(s): See Attachment D Equipment Table

Design Capacity (examples: furnaces - tons/hr, tanks - gallons): See Attachment D Equipment Table

Maximum Hourly Throughput:	Maximum Annual Throughput:	Maximum Operating Schedule: 24 hrs/day, 365 days/yr
-----------------------------------	-----------------------------------	---

Fuel Usage Data (fill out all applicable fields)

Does this emission unit combust fuel? ___ Yes <u> X </u> No	If yes, is it? ___ Indirect Fired ___ Direct Fired
Maximum design heat input and/or maximum horsepower rating:	Type and Btu/hr rating of burners:

List the primary fuel type(s) and if applicable, the secondary fuel type(s). For each fuel type listed, provide the maximum hourly and annual fuel usage for each.

Describe each fuel expected to be used during the term of the permit.

Fuel Type	Max. Sulfur Content	Max. Ash Content	BTU Value

Union Carbide Corporation South Charleston Facility – Chemical Mixing Plant

<i>Emissions Data</i>		
Criteria Pollutants	Potential Emissions	
	PPH	TPY
Carbon Monoxide (CO)		
Nitrogen Oxides (NO _x)		
Lead (Pb)		
Particulate Matter (PM _{2.5})		
Particulate Matter (PM ₁₀)		
Total Particulate Matter (TSP)		
Sulfur Dioxide (SO ₂)		
Volatile Organic Compounds (VOC)		
Hazardous Air Pollutants	Potential Emissions	
	PPH	TPY
Regulated Pollutants other than Criteria and HAP	Potential Emissions	
	PPH	TPY

List the method(s) used to calculate the potential emissions (include dates of any stack tests conducted, versions of software used, source and dates of emission factors, etc.).

Applicable Requirements

List all applicable requirements for this emission unit. For each applicable requirement, include the underlying rule/regulation citation and/or construction permit with the condition number. (Note: Title V permit condition numbers alone are not the underlying applicable requirements). If an emission limit is calculated based on the type of source and design capacity or if a standard is based on a design parameter, this information should also be included.

See Attachment I for applicable requirements, monitoring, recordkeeping, reporting and testing from existing Title V permit.

X Permit Shield

For all applicable requirements listed above, provide monitoring/testing/recordkeeping/reporting which shall be used to demonstrate compliance. If the method is based on a permit or rule, include the condition number or citation. (Note: Each requirement listed above must have an associated method of demonstrating compliance. If there is not already a required method in place, then a method must be proposed.)

See Attachment I for applicable requirements, monitoring, recordkeeping, reporting and testing from existing Title V permit.

Are you in compliance with all applicable requirements for this emission unit? X Yes No

If no, complete the **Schedule of Compliance Form** as **ATTACHMENT F**.

ATTACHMENT E - Emission Unit Form

Emission Unit Description: Storage Tank

Emission unit ID number: 2062	Emission unit name: Tank 2062	List any control devices associated with this emission unit:
---	---	---

Provide a description of the emission unit (type, method of operation, design parameters, etc.):

Storage of volatile organic liquid

Manufacturer:	Model number:	Serial number:
Construction date: See Attachment D Equipment Table	Installation date: See Attachment D Equipment Table	Modification date(s): See Attachment D Equipment Table

Design Capacity (examples: furnaces - tons/hr, tanks - gallons): See Attachment D Equipment Table

Maximum Hourly Throughput:	Maximum Annual Throughput:	Maximum Operating Schedule: 24 hrs/day, 365 days/yr
-----------------------------------	-----------------------------------	---

Fuel Usage Data (fill out all applicable fields)

Does this emission unit combust fuel? ___ Yes <u> X </u> No	If yes, is it? ___ Indirect Fired ___ Direct Fired
Maximum design heat input and/or maximum horsepower rating:	Type and Btu/hr rating of burners:

List the primary fuel type(s) and if applicable, the secondary fuel type(s). For each fuel type listed, provide the maximum hourly and annual fuel usage for each.

Describe each fuel expected to be used during the term of the permit.

Fuel Type	Max. Sulfur Content	Max. Ash Content	BTU Value

Union Carbide Corporation South Charleston Facility – Chemical Mixing Plant

<i>Emissions Data</i>		
Criteria Pollutants	Potential Emissions	
	PPH	TPY
Carbon Monoxide (CO)		
Nitrogen Oxides (NO _x)		
Lead (Pb)		
Particulate Matter (PM _{2.5})		
Particulate Matter (PM ₁₀)		
Total Particulate Matter (TSP)		
Sulfur Dioxide (SO ₂)		
Volatile Organic Compounds (VOC)		
Hazardous Air Pollutants	Potential Emissions	
	PPH	TPY
Regulated Pollutants other than Criteria and HAP	Potential Emissions	
	PPH	TPY

List the method(s) used to calculate the potential emissions (include dates of any stack tests conducted, versions of software used, source and dates of emission factors, etc.).

Applicable Requirements

List all applicable requirements for this emission unit. For each applicable requirement, include the underlying rule/regulation citation and/or construction permit with the condition number. (Note: Title V permit condition numbers alone are not the underlying applicable requirements). If an emission limit is calculated based on the type of source and design capacity or if a standard is based on a design parameter, this information should also be included.

See Attachment I for applicable requirements, monitoring, recordkeeping, reporting and testing from existing Title V permit.

Permit Shield

For all applicable requirements listed above, provide monitoring/testing/recordkeeping/reporting which shall be used to demonstrate compliance. If the method is based on a permit or rule, include the condition number or citation. (Note: Each requirement listed above must have an associated method of demonstrating compliance. If there is not already a required method in place, then a method must be proposed.)

See Attachment I for applicable requirements, monitoring, recordkeeping, reporting and testing from existing Title V permit.

Are you in compliance with all applicable requirements for this emission unit? Yes No

If no, complete the **Schedule of Compliance Form** as ATTACHMENT F.

ATTACHMENT E - Emission Unit Form

Emission Unit Description: Storage Tank

Emission unit ID number: 2061	Emission unit name: Tank 2061	List any control devices associated with this emission unit:
---	---	---

Provide a description of the emission unit (type, method of operation, design parameters, etc.):

Storage of volatile organic liquid

Manufacturer:	Model number:	Serial number:
Construction date: See Attachment D Equipment Table	Installation date: See Attachment D Equipment Table	Modification date(s): See Attachment D Equipment Table

Design Capacity (examples: furnaces - tons/hr, tanks - gallons): See Attachment D Equipment Table

Maximum Hourly Throughput:	Maximum Annual Throughput:	Maximum Operating Schedule: 24 hrs/day, 365 days/yr
-----------------------------------	-----------------------------------	---

Fuel Usage Data (fill out all applicable fields)

Does this emission unit combust fuel? ___Yes <u>X</u> No	If yes, is it? ___ Indirect Fired ___ Direct Fired
Maximum design heat input and/or maximum horsepower rating:	Type and Btu/hr rating of burners:

List the primary fuel type(s) and if applicable, the secondary fuel type(s). For each fuel type listed, provide the maximum hourly and annual fuel usage for each.

Describe each fuel expected to be used during the term of the permit.

Fuel Type	Max. Sulfur Content	Max. Ash Content	BTU Value

Union Carbide Corporation South Charleston Facility – Chemical Mixing Plant

<i>Emissions Data</i>		
Criteria Pollutants	Potential Emissions	
	PPH	TPY
Carbon Monoxide (CO)		
Nitrogen Oxides (NO _x)		
Lead (Pb)		
Particulate Matter (PM _{2.5})		
Particulate Matter (PM ₁₀)		
Total Particulate Matter (TSP)		
Sulfur Dioxide (SO ₂)		
Volatile Organic Compounds (VOC)		
Hazardous Air Pollutants	Potential Emissions	
	PPH	TPY
Regulated Pollutants other than Criteria and HAP	Potential Emissions	
	PPH	TPY

List the method(s) used to calculate the potential emissions (include dates of any stack tests conducted, versions of software used, source and dates of emission factors, etc.).

Applicable Requirements

List all applicable requirements for this emission unit. For each applicable requirement, include the underlying rule/regulation citation and/or construction permit with the condition number. (Note: Title V permit condition numbers alone are not the underlying applicable requirements). If an emission limit is calculated based on the type of source and design capacity or if a standard is based on a design parameter, this information should also be included.

See Attachment I for applicable requirements, monitoring, recordkeeping, reporting and testing from existing Title V permit.

Permit Shield

For all applicable requirements listed above, provide monitoring/testing/recordkeeping/reporting which shall be used to demonstrate compliance. If the method is based on a permit or rule, include the condition number or citation. (Note: Each requirement listed above must have an associated method of demonstrating compliance. If there is not already a required method in place, then a method must be proposed.)

See Attachment I for applicable requirements, monitoring, recordkeeping, reporting and testing from existing Title V permit.

Are you in compliance with all applicable requirements for this emission unit? Yes No

If no, complete the **Schedule of Compliance Form** as ATTACHMENT F.

ATTACHMENT E - Emission Unit Form

Emission Unit Description: Storage Tank

Emission unit ID number: 2065	Emission unit name: Tank 2065	List any control devices associated with this emission unit:
---	---	---

Provide a description of the emission unit (type, method of operation, design parameters, etc.):

Storage of volatile organic liquid

Manufacturer:	Model number:	Serial number:
Construction date: See Attachment D Equipment Table	Installation date: See Attachment D Equipment Table	Modification date(s): See Attachment D Equipment Table

Design Capacity (examples: furnaces - tons/hr, tanks - gallons): See Attachment D Equipment Table

Maximum Hourly Throughput:	Maximum Annual Throughput:	Maximum Operating Schedule: 24 hrs/day, 365 days/yr
-----------------------------------	-----------------------------------	---

Fuel Usage Data (fill out all applicable fields)

Does this emission unit combust fuel? ___Yes <u>X</u> No	If yes, is it? ___ Indirect Fired ___ Direct Fired
Maximum design heat input and/or maximum horsepower rating:	Type and Btu/hr rating of burners:

List the primary fuel type(s) and if applicable, the secondary fuel type(s). For each fuel type listed, provide the maximum hourly and annual fuel usage for each.

Describe each fuel expected to be used during the term of the permit.

Fuel Type	Max. Sulfur Content	Max. Ash Content	BTU Value

Union Carbide Corporation South Charleston Facility – Chemical Mixing Plant

<i>Emissions Data</i>		
Criteria Pollutants	Potential Emissions	
	PPH	TPY
Carbon Monoxide (CO)		
Nitrogen Oxides (NO _x)		
Lead (Pb)		
Particulate Matter (PM _{2.5})		
Particulate Matter (PM ₁₀)		
Total Particulate Matter (TSP)		
Sulfur Dioxide (SO ₂)		
Volatile Organic Compounds (VOC)		
Hazardous Air Pollutants	Potential Emissions	
	PPH	TPY
Regulated Pollutants other than Criteria and HAP	Potential Emissions	
	PPH	TPY

List the method(s) used to calculate the potential emissions (include dates of any stack tests conducted, versions of software used, source and dates of emission factors, etc.).

Applicable Requirements

List all applicable requirements for this emission unit. For each applicable requirement, include the underlying rule/regulation citation and/or construction permit with the condition number. (Note: Title V permit condition numbers alone are not the underlying applicable requirements). If an emission limit is calculated based on the type of source and design capacity or if a standard is based on a design parameter, this information should also be included.

See Attachment I for applicable requirements, monitoring, recordkeeping, reporting and testing from existing Title V permit.

X Permit Shield

For all applicable requirements listed above, provide monitoring/testing/recordkeeping/reporting which shall be used to demonstrate compliance. If the method is based on a permit or rule, include the condition number or citation. (Note: Each requirement listed above must have an associated method of demonstrating compliance. If there is not already a required method in place, then a method must be proposed.)

See Attachment I for applicable requirements, monitoring, recordkeeping, reporting and testing from existing Title V permit.

Are you in compliance with all applicable requirements for this emission unit? X Yes No

If no, complete the **Schedule of Compliance Form** as **ATTACHMENT F**.

ATTACHMENT E - Emission Unit Form

Emission Unit Description: Storage Tank

Emission unit ID number: 2066	Emission unit name: Tank 2066	List any control devices associated with this emission unit:
---	---	---

Provide a description of the emission unit (type, method of operation, design parameters, etc.):

Storage of volatile organic liquid

Manufacturer:	Model number:	Serial number:
Construction date: See Attachment D Equipment Table	Installation date: See Attachment D Equipment Table	Modification date(s): See Attachment D Equipment Table

Design Capacity (examples: furnaces - tons/hr, tanks - gallons): See Attachment D Equipment Table

Maximum Hourly Throughput:	Maximum Annual Throughput:	Maximum Operating Schedule: 24 hrs/day, 365 days/yr
-----------------------------------	-----------------------------------	---

Fuel Usage Data (fill out all applicable fields)

Does this emission unit combust fuel? ___ Yes <u> X </u> No	If yes, is it? ___ Indirect Fired ___ Direct Fired
Maximum design heat input and/or maximum horsepower rating:	Type and Btu/hr rating of burners:

List the primary fuel type(s) and if applicable, the secondary fuel type(s). For each fuel type listed, provide the maximum hourly and annual fuel usage for each.

Describe each fuel expected to be used during the term of the permit.

Fuel Type	Max. Sulfur Content	Max. Ash Content	BTU Value

Union Carbide Corporation South Charleston Facility – Chemical Mixing Plant

Emissions Data		
Criteria Pollutants	Potential Emissions	
	PPH	TPY
Carbon Monoxide (CO)		
Nitrogen Oxides (NO _x)		
Lead (Pb)		
Particulate Matter (PM _{2.5})		
Particulate Matter (PM ₁₀)		
Total Particulate Matter (TSP)		
Sulfur Dioxide (SO ₂)		
Volatile Organic Compounds (VOC)		
Hazardous Air Pollutants	Potential Emissions	
	PPH	TPY
Regulated Pollutants other than Criteria and HAP	Potential Emissions	
	PPH	TPY

List the method(s) used to calculate the potential emissions (include dates of any stack tests conducted, versions of software used, source and dates of emission factors, etc.).

Applicable Requirements

List all applicable requirements for this emission unit. For each applicable requirement, include the underlying rule/regulation citation and/or construction permit with the condition number. (Note: Title V permit condition numbers alone are not the underlying applicable requirements). If an emission limit is calculated based on the type of source and design capacity or if a standard is based on a design parameter, this information should also be included.

See Attachment I for applicable requirements, monitoring, recordkeeping, reporting and testing from existing Title V permit.

Permit Shield

For all applicable requirements listed above, provide monitoring/testing/recordkeeping/reporting which shall be used to demonstrate compliance. If the method is based on a permit or rule, include the condition number or citation. (Note: Each requirement listed above must have an associated method of demonstrating compliance. If there is not already a required method in place, then a method must be proposed.)

See Attachment I for applicable requirements, monitoring, recordkeeping, reporting and testing from existing Title V permit.

Are you in compliance with all applicable requirements for this emission unit? Yes No

If no, complete the **Schedule of Compliance Form** as ATTACHMENT F.

ATTACHMENT E - Emission Unit Form

Emission Unit Description: Storage Tank

Emission unit ID number: 9000	Emission unit name: Tank 9000	List any control devices associated with this emission unit:
---	---	---

Provide a description of the emission unit (type, method of operation, design parameters, etc.):

Storage of volatile organic liquid – Located at NCDT

Manufacturer:	Model number:	Serial number:
Construction date: See Attachment D Equipment Table	Installation date: See Attachment D Equipment Table	Modification date(s): See Attachment D Equipment Table

Design Capacity (examples: furnaces - tons/hr, tanks - gallons): See Attachment D Equipment Table

Maximum Hourly Throughput:	Maximum Annual Throughput:	Maximum Operating Schedule: 24 hrs/day, 365 days/yr
-----------------------------------	-----------------------------------	---

Fuel Usage Data (fill out all applicable fields)

Does this emission unit combust fuel? ___ Yes <u> X </u> No	If yes, is it? ___ Indirect Fired ___ Direct Fired
Maximum design heat input and/or maximum horsepower rating:	Type and Btu/hr rating of burners:

List the primary fuel type(s) and if applicable, the secondary fuel type(s). For each fuel type listed, provide the maximum hourly and annual fuel usage for each.

Describe each fuel expected to be used during the term of the permit.

Fuel Type	Max. Sulfur Content	Max. Ash Content	BTU Value

Union Carbide Corporation South Charleston Facility – Chemical Mixing Plant

Emissions Data		
Criteria Pollutants	Potential Emissions	
	PPH	TPY
Carbon Monoxide (CO)		
Nitrogen Oxides (NO _x)		
Lead (Pb)		
Particulate Matter (PM _{2.5})		
Particulate Matter (PM ₁₀)		
Total Particulate Matter (TSP)		
Sulfur Dioxide (SO ₂)		
Volatile Organic Compounds (VOC)		
Hazardous Air Pollutants	Potential Emissions	
	PPH	TPY
Regulated Pollutants other than Criteria and HAP	Potential Emissions	
	PPH	TPY

List the method(s) used to calculate the potential emissions (include dates of any stack tests conducted, versions of software used, source and dates of emission factors, etc.).

Applicable Requirements

List all applicable requirements for this emission unit. For each applicable requirement, include the underlying rule/regulation citation and/or construction permit with the condition number. (Note: Title V permit condition numbers alone are not the underlying applicable requirements). If an emission limit is calculated based on the type of source and design capacity or if a standard is based on a design parameter, this information should also be included.

See Attachment I for applicable requirements, monitoring, recordkeeping, reporting and testing from existing Title V permit.

Permit Shield

For all applicable requirements listed above, provide monitoring/testing/recordkeeping/reporting which shall be used to demonstrate compliance. If the method is based on a permit or rule, include the condition number or citation. (Note: Each requirement listed above must have an associated method of demonstrating compliance. If there is not already a required method in place, then a method must be proposed.)

See Attachment I for applicable requirements, monitoring, recordkeeping, reporting and testing from existing Title V permit.

Are you in compliance with all applicable requirements for this emission unit? Yes No

If no, complete the **Schedule of Compliance Form** as ATTACHMENT F.

ATTACHMENT E - Emission Unit Form

Emission Unit Description: Vessel

Emission unit ID number: D-104	Emission unit name: Vessel D-104E	List any control devices associated with this emission unit:
--	---	---

Provide a description of the emission unit (type, method of operation, design parameters, etc.):

Manufacturer:	Model number:	Serial number:
----------------------	----------------------	-----------------------

Construction date: See Attachment D Equipment Table	Installation date: See Attachment D Equipment Table	Modification date(s): See Attachment D Equipment Table
---	---	--

Design Capacity (examples: furnaces - tons/hr, tanks - gallons): See Attachment D Equipment Table

Maximum Hourly Throughput:	Maximum Annual Throughput:	Maximum Operating Schedule: 24 hrs/day, 365 days/yr
-----------------------------------	-----------------------------------	---

Fuel Usage Data (fill out all applicable fields)

Does this emission unit combust fuel? ___Yes <u>X</u> No	If yes, is it? ___ Indirect Fired ___Direct Fired
---	---

Maximum design heat input and/or maximum horsepower rating:	Type and Btu/hr rating of burners:
--	---

List the primary fuel type(s) and if applicable, the secondary fuel type(s). For each fuel type listed, provide the maximum hourly and annual fuel usage for each.

Describe each fuel expected to be used during the term of the permit.

Fuel Type	Max. Sulfur Content	Max. Ash Content	BTU Value

Union Carbide Corporation South Charleston Facility – Chemical Mixing Plant

Emissions Data		
Criteria Pollutants	Potential Emissions	
	PPH	TPY
Carbon Monoxide (CO)		
Nitrogen Oxides (NO _x)		
Lead (Pb)		
Particulate Matter (PM _{2.5})		
Particulate Matter (PM ₁₀)		
Total Particulate Matter (TSP)		
Sulfur Dioxide (SO ₂)		
Volatile Organic Compounds (VOC)		
Hazardous Air Pollutants	Potential Emissions	
	PPH	TPY
Regulated Pollutants other than Criteria and HAP	Potential Emissions	
	PPH	TPY

List the method(s) used to calculate the potential emissions (include dates of any stack tests conducted, versions of software used, source and dates of emission factors, etc.).

Applicable Requirements

List all applicable requirements for this emission unit. For each applicable requirement, include the underlying rule/regulation citation and/or construction permit with the condition number. (Note: Title V permit condition numbers alone are not the underlying applicable requirements). If an emission limit is calculated based on the type of source and design capacity or if a standard is based on a design parameter, this information should also be included.

See Attachment I for applicable requirements, monitoring, recordkeeping, reporting and testing from existing Title V permit.

Permit Shield

For all applicable requirements listed above, provide monitoring/testing/recordkeeping/reporting which shall be used to demonstrate compliance. If the method is based on a permit or rule, include the condition number or citation. (Note: Each requirement listed above must have an associated method of demonstrating compliance. If there is not already a required method in place, then a method must be proposed.)

See Attachment I for applicable requirements, monitoring, recordkeeping, reporting and testing from existing Title V permit.

Are you in compliance with all applicable requirements for this emission unit? Yes No

If no, complete the **Schedule of Compliance Form** as ATTACHMENT F.

ATTACHMENT E - Emission Unit Form

Emission Unit Description: Material Loading

Emission unit ID number: L050DR	Emission unit name: In Unit Drum Loading	List any control devices associated with this emission unit:
---	--	---

Provide a description of the emission unit (type, method of operation, design parameters, etc.):

Manufacturer:	Model number:	Serial number:
Construction date: See Attachment D Equipment Table	Installation date: See Attachment D Equipment Table	Modification date(s): See Attachment D Equipment Table

Design Capacity (examples: furnaces - tons/hr, tanks - gallons): See Attachment D Equipment Table

Maximum Hourly Throughput:	Maximum Annual Throughput:	Maximum Operating Schedule: 24 hrs/day, 365 days/yr
-----------------------------------	-----------------------------------	---

Fuel Usage Data (fill out all applicable fields)

Does this emission unit combust fuel? ___Yes <input checked="" type="checkbox"/> No	If yes, is it? ___ Indirect Fired ___Direct Fired
Maximum design heat input and/or maximum horsepower rating:	Type and Btu/hr rating of burners:

List the primary fuel type(s) and if applicable, the secondary fuel type(s). For each fuel type listed, provide the maximum hourly and annual fuel usage for each.

Describe each fuel expected to be used during the term of the permit.

Fuel Type	Max. Sulfur Content	Max. Ash Content	BTU Value

Union Carbide Corporation South Charleston Facility – Chemical Mixing Plant

<i>Emissions Data</i>		
Criteria Pollutants	Potential Emissions	
	PPH	TPY
Carbon Monoxide (CO)		
Nitrogen Oxides (NO _x)		
Lead (Pb)		
Particulate Matter (PM _{2.5})		
Particulate Matter (PM ₁₀)		
Total Particulate Matter (TSP)		
Sulfur Dioxide (SO ₂)		
Volatile Organic Compounds (VOC)		
Hazardous Air Pollutants	Potential Emissions	
	PPH	TPY
Regulated Pollutants other than Criteria and HAP	Potential Emissions	
	PPH	TPY

List the method(s) used to calculate the potential emissions (include dates of any stack tests conducted, versions of software used, source and dates of emission factors, etc.).

Applicable Requirements

List all applicable requirements for this emission unit. For each applicable requirement, include the underlying rule/regulation citation and/or construction permit with the condition number. (Note: Title V permit condition numbers alone are not the underlying applicable requirements). If an emission limit is calculated based on the type of source and design capacity or if a standard is based on a design parameter, this information should also be included.

See Attachment I for applicable requirements, monitoring, recordkeeping, reporting and testing from existing Title V permit.

X Permit Shield

For all applicable requirements listed above, provide monitoring/testing/recordkeeping/reporting which shall be used to demonstrate compliance. If the method is based on a permit or rule, include the condition number or citation. (Note: Each requirement listed above must have an associated method of demonstrating compliance. If there is not already a required method in place, then a method must be proposed.)

See Attachment I for applicable requirements, monitoring, recordkeeping, reporting and testing from existing Title V permit.

Are you in compliance with all applicable requirements for this emission unit? X Yes No

If no, complete the **Schedule of Compliance Form** as **ATTACHMENT F**.

ATTACHMENT E - Emission Unit Form

Emission Unit Description: Transfer Rack

Emission unit ID number: L050RC	Emission unit name: In Unit Rail Car Rack	List any control devices associated with this emission unit:
---	---	---

Provide a description of the emission unit (type, method of operation, design parameters, etc.):

Manufacturer:	Model number:	Serial number:
Construction date: See Attachment D Equipment Table	Installation date: See Attachment D Equipment Table	Modification date(s): See Attachment D Equipment Table

Design Capacity (examples: furnaces - tons/hr, tanks - gallons): See Attachment D Equipment Table

Maximum Hourly Throughput:	Maximum Annual Throughput:	Maximum Operating Schedule: 24 hrs/day, 365 days/yr
-----------------------------------	-----------------------------------	---

Fuel Usage Data (fill out all applicable fields)

Does this emission unit combust fuel? ___Yes <u>X</u> No	If yes, is it? ___ Indirect Fired ___Direct Fired
Maximum design heat input and/or maximum horsepower rating:	Type and Btu/hr rating of burners:

List the primary fuel type(s) and if applicable, the secondary fuel type(s). For each fuel type listed, provide the maximum hourly and annual fuel usage for each.

Describe each fuel expected to be used during the term of the permit.

Fuel Type	Max. Sulfur Content	Max. Ash Content	BTU Value

Union Carbide Corporation South Charleston Facility – Chemical Mixing Plant

<i>Emissions Data</i>		
Criteria Pollutants	Potential Emissions	
	PPH	TPY
Carbon Monoxide (CO)		
Nitrogen Oxides (NO _x)		
Lead (Pb)		
Particulate Matter (PM _{2.5})		
Particulate Matter (PM ₁₀)		
Total Particulate Matter (TSP)		
Sulfur Dioxide (SO ₂)		
Volatile Organic Compounds (VOC)		
Hazardous Air Pollutants	Potential Emissions	
	PPH	TPY
Regulated Pollutants other than Criteria and HAP	Potential Emissions	
	PPH	TPY

List the method(s) used to calculate the potential emissions (include dates of any stack tests conducted, versions of software used, source and dates of emission factors, etc.).

Applicable Requirements

List all applicable requirements for this emission unit. For each applicable requirement, include the underlying rule/regulation citation and/or construction permit with the condition number. (Note: Title V permit condition numbers alone are not the underlying applicable requirements). If an emission limit is calculated based on the type of source and design capacity or if a standard is based on a design parameter, this information should also be included.

See Attachment I for applicable requirements, monitoring, recordkeeping, reporting and testing from existing Title V permit.

X Permit Shield

For all applicable requirements listed above, provide monitoring/testing/recordkeeping/reporting which shall be used to demonstrate compliance. If the method is based on a permit or rule, include the condition number or citation. (Note: Each requirement listed above must have an associated method of demonstrating compliance. If there is not already a required method in place, then a method must be proposed.)

See Attachment I for applicable requirements, monitoring, recordkeeping, reporting and testing from existing Title V permit.

Are you in compliance with all applicable requirements for this emission unit? X Yes No

If no, complete the **Schedule of Compliance Form** as **ATTACHMENT F**.

ATTACHMENT E - Emission Unit Form

Emission Unit Description: Transfer Rack

Emission unit ID number: L050TT	Emission unit name: In Unit Tank Truck Rack	List any control devices associated with this emission unit:
---	---	---

Provide a description of the emission unit (type, method of operation, design parameters, etc.):

Manufacturer:	Model number:	Serial number:
Construction date: See Attachment D Equipment Table	Installation date: See Attachment D Equipment Table	Modification date(s): See Attachment D Equipment Table

Design Capacity (examples: furnaces - tons/hr, tanks - gallons): See Attachment D Equipment Table

Maximum Hourly Throughput:	Maximum Annual Throughput:	Maximum Operating Schedule: 24 hrs/day, 365 days/yr
-----------------------------------	-----------------------------------	---

Fuel Usage Data (fill out all applicable fields)

Does this emission unit combust fuel? ___Yes <input checked="" type="checkbox"/> No	If yes, is it? ___ Indirect Fired ___Direct Fired
Maximum design heat input and/or maximum horsepower rating:	Type and Btu/hr rating of burners:

List the primary fuel type(s) and if applicable, the secondary fuel type(s). For each fuel type listed, provide the maximum hourly and annual fuel usage for each.

Describe each fuel expected to be used during the term of the permit.

Fuel Type	Max. Sulfur Content	Max. Ash Content	BTU Value

Union Carbide Corporation South Charleston Facility – Chemical Mixing Plant

<i>Emissions Data</i>		
Criteria Pollutants	Potential Emissions	
	PPH	TPY
Carbon Monoxide (CO)		
Nitrogen Oxides (NO _x)		
Lead (Pb)		
Particulate Matter (PM _{2.5})		
Particulate Matter (PM ₁₀)		
Total Particulate Matter (TSP)		
Sulfur Dioxide (SO ₂)		
Volatile Organic Compounds (VOC)		
Hazardous Air Pollutants	Potential Emissions	
	PPH	TPY
Regulated Pollutants other than Criteria and HAP	Potential Emissions	
	PPH	TPY

List the method(s) used to calculate the potential emissions (include dates of any stack tests conducted, versions of software used, source and dates of emission factors, etc.).

Applicable Requirements

List all applicable requirements for this emission unit. For each applicable requirement, include the underlying rule/regulation citation and/or construction permit with the condition number. (Note: Title V permit condition numbers alone are not the underlying applicable requirements). If an emission limit is calculated based on the type of source and design capacity or if a standard is based on a design parameter, this information should also be included.

See Attachment I for applicable requirements, monitoring, recordkeeping, reporting and testing from existing Title V permit.

Permit Shield

For all applicable requirements listed above, provide monitoring/testing/recordkeeping/reporting which shall be used to demonstrate compliance. If the method is based on a permit or rule, include the condition number or citation. (Note: Each requirement listed above must have an associated method of demonstrating compliance. If there is not already a required method in place, then a method must be proposed.)

See Attachment I for applicable requirements, monitoring, recordkeeping, reporting and testing from existing Title V permit.

Are you in compliance with all applicable requirements for this emission unit? Yes No

If no, complete the **Schedule of Compliance Form** as ATTACHMENT F.

ATTACHMENT E - Emission Unit Form

<i>Emission Unit Description</i>			
Emission unit ID number: 2001	Emission unit name: Tank 2001	List any control devices associated with this emission unit:	
Provide a description of the emission unit (type, method of operation, design parameters, etc.): Storage of volatile organic liquid			
Manufacturer:	Model number:	Serial number:	
Construction date: See Attachment D Equipment Table	Installation date: See Attachment D Equipment Table	Modification date(s): See Attachment D Equipment Table	
Design Capacity (examples: furnaces - tons/hr, tanks - gallons): See Attachment D Equipment Table			
Maximum Hourly Throughput:	Maximum Annual Throughput:	Maximum Operating Schedule: 24 hrs/day, 365 days/yr	
<i>Fuel Usage Data (fill out all applicable fields)</i>			
Does this emission unit combust fuel? ___ Yes <u> X </u> No		If yes, is it? ___ Indirect Fired ___ Direct Fired	
Maximum design heat input and/or maximum horsepower rating:		Type and Btu/hr rating of burners:	
List the primary fuel type(s) and if applicable, the secondary fuel type(s). For each fuel type listed, provide the maximum hourly and annual fuel usage for each.			
Describe each fuel expected to be used during the term of the permit.			
Fuel Type	Max. Sulfur Content	Max. Ash Content	BTU Value

Union Carbide Corporation South Charleston Facility – Chemical Mixing Plant

<i>Emissions Data</i>		
Criteria Pollutants	Potential Emissions	
	PPH	TPY
Carbon Monoxide (CO)		
Nitrogen Oxides (NO _x)		
Lead (Pb)		
Particulate Matter (PM _{2.5})		
Particulate Matter (PM ₁₀)		
Total Particulate Matter (TSP)		
Sulfur Dioxide (SO ₂)		
Volatile Organic Compounds (VOC)		
Hazardous Air Pollutants	Potential Emissions	
	PPH	TPY
Regulated Pollutants other than Criteria and HAP	Potential Emissions	
	PPH	TPY

List the method(s) used to calculate the potential emissions (include dates of any stack tests conducted, versions of software used, source and dates of emission factors, etc.).

Applicable Requirements

List all applicable requirements for this emission unit. For each applicable requirement, include the underlying rule/regulation citation and/or construction permit with the condition number. (Note: Title V permit condition numbers alone are not the underlying applicable requirements). If an emission limit is calculated based on the type of source and design capacity or if a standard is based on a design parameter, this information should also be included.

See Attachment I for applicable requirements, monitoring, recordkeeping, reporting and testing from existing Title V permit.

Permit Shield

For all applicable requirements listed above, provide monitoring/testing/recordkeeping/reporting which shall be used to demonstrate compliance. If the method is based on a permit or rule, include the condition number or citation. (Note: Each requirement listed above must have an associated method of demonstrating compliance. If there is not already a required method in place, then a method must be proposed.)

See Attachment I for applicable requirements, monitoring, recordkeeping, reporting and testing from existing Title V permit.

Are you in compliance with all applicable requirements for this emission unit? Yes No

If no, complete the **Schedule of Compliance Form** as ATTACHMENT F.

ATTACHMENT E - Emission Unit Form

Emission Unit Description: Vessel

Emission unit ID number: SL-03	Emission unit name: Vessel SL-03	List any control devices associated with this emission unit:
--	--	---

Provide a description of the emission unit (type, method of operation, design parameters, etc.):

Manufacturer:	Model number:	Serial number:
Construction date: See Attachment D Equipment Table	Installation date: See Attachment D Equipment Table	Modification date(s): See Attachment D Equipment Table

Design Capacity (examples: furnaces - tons/hr, tanks - gallons): See Attachment D Equipment Table

Maximum Hourly Throughput:	Maximum Annual Throughput:	Maximum Operating Schedule: 24 hrs/day, 365 days/yr
-----------------------------------	-----------------------------------	---

Fuel Usage Data (fill out all applicable fields)

Does this emission unit combust fuel? ___Yes <input checked="" type="checkbox"/> No	If yes, is it? ___ Indirect Fired ___Direct Fired
--	---

Maximum design heat input and/or maximum horsepower rating:	Type and Btu/hr rating of burners:
--	---

List the primary fuel type(s) and if applicable, the secondary fuel type(s). For each fuel type listed, provide the maximum hourly and annual fuel usage for each.

Describe each fuel expected to be used during the term of the permit.

Fuel Type	Max. Sulfur Content	Max. Ash Content	BTU Value

Union Carbide Corporation South Charleston Facility – Chemical Mixing Plant

<i>Emissions Data</i>		
Criteria Pollutants	Potential Emissions	
	PPH	TPY
Carbon Monoxide (CO)		
Nitrogen Oxides (NO _x)		
Lead (Pb)		
Particulate Matter (PM _{2.5})		
Particulate Matter (PM ₁₀)		
Total Particulate Matter (TSP)		
Sulfur Dioxide (SO ₂)		
Volatile Organic Compounds (VOC)		
Hazardous Air Pollutants	Potential Emissions	
	PPH	TPY
Regulated Pollutants other than Criteria and HAP	Potential Emissions	
	PPH	TPY

List the method(s) used to calculate the potential emissions (include dates of any stack tests conducted, versions of software used, source and dates of emission factors, etc.).

Applicable Requirements

List all applicable requirements for this emission unit. For each applicable requirement, include the underlying rule/regulation citation and/or construction permit with the condition number. (Note: Title V permit condition numbers alone are not the underlying applicable requirements). If an emission limit is calculated based on the type of source and design capacity or if a standard is based on a design parameter, this information should also be included.

See Attachment I for applicable requirements, monitoring, recordkeeping, reporting and testing from existing Title V permit.

X Permit Shield

For all applicable requirements listed above, provide monitoring/testing/recordkeeping/reporting which shall be used to demonstrate compliance. If the method is based on a permit or rule, include the condition number or citation. (Note: Each requirement listed above must have an associated method of demonstrating compliance. If there is not already a required method in place, then a method must be proposed.)

See Attachment I for applicable requirements, monitoring, recordkeeping, reporting and testing from existing Title V permit.

Are you in compliance with all applicable requirements for this emission unit? X Yes No

If no, complete the **Schedule of Compliance Form** as **ATTACHMENT F**.

ATTACHMENT E - Emission Unit Form

Emission Unit Description: Vessel

Emission unit ID number: SL-02	Emission unit name: Vessel SL-02	List any control devices associated with this emission unit:
--	--	---

Provide a description of the emission unit (type, method of operation, design parameters, etc.):

Manufacturer:	Model number:	Serial number:
Construction date: See Attachment D Equipment Table	Installation date: See Attachment D Equipment Table	Modification date(s): See Attachment D Equipment Table

Design Capacity (examples: furnaces - tons/hr, tanks - gallons): See Attachment D Equipment Table

Maximum Hourly Throughput:	Maximum Annual Throughput:	Maximum Operating Schedule: 24 hrs/day, 365 days/yr
-----------------------------------	-----------------------------------	---

Fuel Usage Data (fill out all applicable fields)

Does this emission unit combust fuel? ___Yes <input checked="" type="checkbox"/> No	If yes, is it? ___ Indirect Fired ___Direct Fired
Maximum design heat input and/or maximum horsepower rating:	Type and Btu/hr rating of burners:

List the primary fuel type(s) and if applicable, the secondary fuel type(s). For each fuel type listed, provide the maximum hourly and annual fuel usage for each.

Describe each fuel expected to be used during the term of the permit.

Fuel Type	Max. Sulfur Content	Max. Ash Content	BTU Value

Union Carbide Corporation South Charleston Facility – Chemical Mixing Plant

<i>Emissions Data</i>		
Criteria Pollutants	Potential Emissions	
	PPH	TPY
Carbon Monoxide (CO)		
Nitrogen Oxides (NO _x)		
Lead (Pb)		
Particulate Matter (PM _{2.5})		
Particulate Matter (PM ₁₀)		
Total Particulate Matter (TSP)		
Sulfur Dioxide (SO ₂)		
Volatile Organic Compounds (VOC)		
Hazardous Air Pollutants	Potential Emissions	
	PPH	TPY
Regulated Pollutants other than Criteria and HAP	Potential Emissions	
	PPH	TPY

List the method(s) used to calculate the potential emissions (include dates of any stack tests conducted, versions of software used, source and dates of emission factors, etc.).

Applicable Requirements

List all applicable requirements for this emission unit. For each applicable requirement, include the underlying rule/regulation citation and/or construction permit with the condition number. (Note: Title V permit condition numbers alone are not the underlying applicable requirements). If an emission limit is calculated based on the type of source and design capacity or if a standard is based on a design parameter, this information should also be included.

See Attachment I for applicable requirements, monitoring, recordkeeping, reporting and testing from existing Title V permit.

Permit Shield

For all applicable requirements listed above, provide monitoring/testing/recordkeeping/reporting which shall be used to demonstrate compliance. If the method is based on a permit or rule, include the condition number or citation. (Note: Each requirement listed above must have an associated method of demonstrating compliance. If there is not already a required method in place, then a method must be proposed.)

See Attachment I for applicable requirements, monitoring, recordkeeping, reporting and testing from existing Title V permit.

Are you in compliance with all applicable requirements for this emission unit? Yes No

If no, complete the **Schedule of Compliance Form** as ATTACHMENT F.

ATTACHMENT E - Emission Unit Form

Emission Unit Description: Vessel

Emission unit ID number: SL-01	Emission unit name: Vessel SL-01	List any control devices associated with this emission unit:
--	--	---

Provide a description of the emission unit (type, method of operation, design parameters, etc.):

Manufacturer:	Model number:	Serial number:
Construction date: See Attachment D Equipment Table	Installation date: See Attachment D Equipment Table	Modification date(s): See Attachment D Equipment Table

Design Capacity (examples: furnaces - tons/hr, tanks - gallons): See Attachment D Equipment Table

Maximum Hourly Throughput:	Maximum Annual Throughput:	Maximum Operating Schedule: 24 hrs/day, 365 days/yr
-----------------------------------	-----------------------------------	---

Fuel Usage Data (fill out all applicable fields)

Does this emission unit combust fuel? ___Yes <u>X</u> No	If yes, is it? ___ Indirect Fired ___Direct Fired
Maximum design heat input and/or maximum horsepower rating:	Type and Btu/hr rating of burners:

List the primary fuel type(s) and if applicable, the secondary fuel type(s). For each fuel type listed, provide the maximum hourly and annual fuel usage for each.

Describe each fuel expected to be used during the term of the permit.

Fuel Type	Max. Sulfur Content	Max. Ash Content	BTU Value

Union Carbide Corporation South Charleston Facility – Chemical Mixing Plant

<i>Emissions Data</i>		
Criteria Pollutants	Potential Emissions	
	PPH	TPY
Carbon Monoxide (CO)		
Nitrogen Oxides (NO _x)		
Lead (Pb)		
Particulate Matter (PM _{2.5})		
Particulate Matter (PM ₁₀)		
Total Particulate Matter (TSP)		
Sulfur Dioxide (SO ₂)		
Volatile Organic Compounds (VOC)		
Hazardous Air Pollutants	Potential Emissions	
	PPH	TPY
Regulated Pollutants other than Criteria and HAP	Potential Emissions	
	PPH	TPY

List the method(s) used to calculate the potential emissions (include dates of any stack tests conducted, versions of software used, source and dates of emission factors, etc.).

Applicable Requirements

List all applicable requirements for this emission unit. For each applicable requirement, include the underlying rule/regulation citation and/or construction permit with the condition number. (Note: Title V permit condition numbers alone are not the underlying applicable requirements). If an emission limit is calculated based on the type of source and design capacity or if a standard is based on a design parameter, this information should also be included.

See Attachment I for applicable requirements, monitoring, recordkeeping, reporting and testing from existing Title V permit.

X Permit Shield

For all applicable requirements listed above, provide monitoring/testing/recordkeeping/reporting which shall be used to demonstrate compliance. If the method is based on a permit or rule, include the condition number or citation. (Note: Each requirement listed above must have an associated method of demonstrating compliance. If there is not already a required method in place, then a method must be proposed.)

See Attachment I for applicable requirements, monitoring, recordkeeping, reporting and testing from existing Title V permit.

Are you in compliance with all applicable requirements for this emission unit? X Yes No

If no, complete the **Schedule of Compliance Form** as **ATTACHMENT F**.

ATTACHMENT E - Emission Unit Form

Emission Unit Description: Storage Tank

Emission unit ID number: 2003	Emission unit name: Tank 2003	List any control devices associated with this emission unit:	
Provide a description of the emission unit (type, method of operation, design parameters, etc.): Storage of volatile organic liquid			
Manufacturer:	Model number:	Serial number:	
Construction date: See Attachment D Equipment Table	Installation date: See Attachment D Equipment Table	Modification date(s): See Attachment D Equipment Table	
Design Capacity (examples: furnaces - tons/hr, tanks - gallons): See Attachment D Equipment Table			
Maximum Hourly Throughput:	Maximum Annual Throughput:	Maximum Operating Schedule: 24 hrs/day, 365 days/yr	
Fuel Usage Data (fill out all applicable fields)			
Does this emission unit combust fuel? ___Yes <input checked="" type="checkbox"/> No		If yes, is it? ___ Indirect Fired ___ Direct Fired	
Maximum design heat input and/or maximum horsepower rating:		Type and Btu/hr rating of burners:	
List the primary fuel type(s) and if applicable, the secondary fuel type(s). For each fuel type listed, provide the maximum hourly and annual fuel usage for each.			
Describe each fuel expected to be used during the term of the permit.			
Fuel Type	Max. Sulfur Content	Max. Ash Content	BTU Value

Union Carbide Corporation South Charleston Facility – Chemical Mixing Plant

<i>Emissions Data</i>		
Criteria Pollutants	Potential Emissions	
	PPH	TPY
Carbon Monoxide (CO)		
Nitrogen Oxides (NO _x)		
Lead (Pb)		
Particulate Matter (PM _{2.5})		
Particulate Matter (PM ₁₀)		
Total Particulate Matter (TSP)		
Sulfur Dioxide (SO ₂)		
Volatile Organic Compounds (VOC)		
Hazardous Air Pollutants	Potential Emissions	
	PPH	TPY
Regulated Pollutants other than Criteria and HAP	Potential Emissions	
	PPH	TPY

List the method(s) used to calculate the potential emissions (include dates of any stack tests conducted, versions of software used, source and dates of emission factors, etc.).

Applicable Requirements

List all applicable requirements for this emission unit. For each applicable requirement, include the underlying rule/regulation citation and/or construction permit with the condition number. (Note: Title V permit condition numbers alone are not the underlying applicable requirements). If an emission limit is calculated based on the type of source and design capacity or if a standard is based on a design parameter, this information should also be included.

See Attachment I for applicable requirements, monitoring, recordkeeping, reporting and testing from existing Title V permit.

Permit Shield

For all applicable requirements listed above, provide monitoring/testing/recordkeeping/reporting which shall be used to demonstrate compliance. If the method is based on a permit or rule, include the condition number or citation. (Note: Each requirement listed above must have an associated method of demonstrating compliance. If there is not already a required method in place, then a method must be proposed.)

See Attachment I for applicable requirements, monitoring, recordkeeping, reporting and testing from existing Title V permit.

Are you in compliance with all applicable requirements for this emission unit? Yes No

If no, complete the **Schedule of Compliance Form** as ATTACHMENT F.

ATTACHMENT E - Emission Unit Form

Emission Unit Description: Storage Tank

Emission unit ID number: 2008	Emission unit name: Tank 2008	List any control devices associated with this emission unit:
---	---	---

Provide a description of the emission unit (type, method of operation, design parameters, etc.):

Storage of volatile organic liquid

Manufacturer:	Model number:	Serial number:
Construction date: See Attachment D Equipment Table	Installation date: See Attachment D Equipment Table	Modification date(s): See Attachment D Equipment Table

Design Capacity (examples: furnaces - tons/hr, tanks - gallons): See Attachment D Equipment Table

Maximum Hourly Throughput:	Maximum Annual Throughput:	Maximum Operating Schedule: 24 hrs/day, 365 days/yr
-----------------------------------	-----------------------------------	---

Fuel Usage Data (fill out all applicable fields)

Does this emission unit combust fuel? ___ Yes <u> X </u> No	If yes, is it? ___ Indirect Fired ___ Direct Fired
Maximum design heat input and/or maximum horsepower rating:	Type and Btu/hr rating of burners:

List the primary fuel type(s) and if applicable, the secondary fuel type(s). For each fuel type listed, provide the maximum hourly and annual fuel usage for each.

Describe each fuel expected to be used during the term of the permit.

Fuel Type	Max. Sulfur Content	Max. Ash Content	BTU Value

Union Carbide Corporation South Charleston Facility – Chemical Mixing Plant

<i>Emissions Data</i>		
Criteria Pollutants	Potential Emissions	
	PPH	TPY
Carbon Monoxide (CO)		
Nitrogen Oxides (NO _x)		
Lead (Pb)		
Particulate Matter (PM _{2.5})		
Particulate Matter (PM ₁₀)		
Total Particulate Matter (TSP)		
Sulfur Dioxide (SO ₂)		
Volatile Organic Compounds (VOC)		
Hazardous Air Pollutants	Potential Emissions	
	PPH	TPY
Regulated Pollutants other than Criteria and HAP	Potential Emissions	
	PPH	TPY

List the method(s) used to calculate the potential emissions (include dates of any stack tests conducted, versions of software used, source and dates of emission factors, etc.).

Applicable Requirements

List all applicable requirements for this emission unit. For each applicable requirement, include the underlying rule/regulation citation and/or construction permit with the condition number. (Note: Title V permit condition numbers alone are not the underlying applicable requirements). If an emission limit is calculated based on the type of source and design capacity or if a standard is based on a design parameter, this information should also be included.

See Attachment I for applicable requirements, monitoring, recordkeeping, reporting and testing from existing Title V permit.

Permit Shield

For all applicable requirements listed above, provide monitoring/testing/recordkeeping/reporting which shall be used to demonstrate compliance. If the method is based on a permit or rule, include the condition number or citation. (Note: Each requirement listed above must have an associated method of demonstrating compliance. If there is not already a required method in place, then a method must be proposed.)

See Attachment I for applicable requirements, monitoring, recordkeeping, reporting and testing from existing Title V permit.

Are you in compliance with all applicable requirements for this emission unit? Yes No

If no, complete the **Schedule of Compliance Form** as ATTACHMENT F.

ATTACHMENT E - Emission Unit Form

Emission Unit Description: Storage Tank

Emission unit ID number: 2007	Emission unit name: Tank 2007	List any control devices associated with this emission unit:
---	---	---

Provide a description of the emission unit (type, method of operation, design parameters, etc.):

Storage of volatile organic liquid

Manufacturer:	Model number:	Serial number:
Construction date: See Attachment D Equipment Table	Installation date: See Attachment D Equipment Table	Modification date(s): See Attachment D Equipment Table

Design Capacity (examples: furnaces - tons/hr, tanks - gallons): See Attachment D Equipment Table

Maximum Hourly Throughput:	Maximum Annual Throughput:	Maximum Operating Schedule: 24 hrs/day, 365 days/yr
-----------------------------------	-----------------------------------	---

Fuel Usage Data (fill out all applicable fields)

Does this emission unit combust fuel? ___ Yes <u> X </u> No	If yes, is it? ___ Indirect Fired ___ Direct Fired
Maximum design heat input and/or maximum horsepower rating:	Type and Btu/hr rating of burners:

List the primary fuel type(s) and if applicable, the secondary fuel type(s). For each fuel type listed, provide the maximum hourly and annual fuel usage for each.

Describe each fuel expected to be used during the term of the permit.

Fuel Type	Max. Sulfur Content	Max. Ash Content	BTU Value

Union Carbide Corporation South Charleston Facility – Chemical Mixing Plant

<i>Emissions Data</i>		
Criteria Pollutants	Potential Emissions	
	PPH	TPY
Carbon Monoxide (CO)		
Nitrogen Oxides (NO _x)		
Lead (Pb)		
Particulate Matter (PM _{2.5})		
Particulate Matter (PM ₁₀)		
Total Particulate Matter (TSP)		
Sulfur Dioxide (SO ₂)		
Volatile Organic Compounds (VOC)		
Hazardous Air Pollutants	Potential Emissions	
	PPH	TPY
Regulated Pollutants other than Criteria and HAP	Potential Emissions	
	PPH	TPY

List the method(s) used to calculate the potential emissions (include dates of any stack tests conducted, versions of software used, source and dates of emission factors, etc.).

Applicable Requirements

List all applicable requirements for this emission unit. For each applicable requirement, include the underlying rule/regulation citation and/or construction permit with the condition number. (Note: Title V permit condition numbers alone are not the underlying applicable requirements). If an emission limit is calculated based on the type of source and design capacity or if a standard is based on a design parameter, this information should also be included.

See Attachment I for applicable requirements, monitoring, recordkeeping, reporting and testing from existing Title V permit.

Permit Shield

For all applicable requirements listed above, provide monitoring/testing/recordkeeping/reporting which shall be used to demonstrate compliance. If the method is based on a permit or rule, include the condition number or citation. (Note: Each requirement listed above must have an associated method of demonstrating compliance. If there is not already a required method in place, then a method must be proposed.)

See Attachment I for applicable requirements, monitoring, recordkeeping, reporting and testing from existing Title V permit.

Are you in compliance with all applicable requirements for this emission unit? Yes No

If no, complete the **Schedule of Compliance Form** as ATTACHMENT F.

ATTACHMENT E - Emission Unit Form

Emission Unit Description: Storage Tank

Emission unit ID number: 2006	Emission unit name: Tank 2006	List any control devices associated with this emission unit:
---	---	---

Provide a description of the emission unit (type, method of operation, design parameters, etc.):

Storage of volatile organic liquid

Manufacturer:	Model number:	Serial number:
Construction date: See Attachment D Equipment Table	Installation date: See Attachment D Equipment Table	Modification date(s): See Attachment D Equipment Table

Design Capacity (examples: furnaces - tons/hr, tanks - gallons): See Attachment D Equipment Table

Maximum Hourly Throughput:	Maximum Annual Throughput:	Maximum Operating Schedule: 24 hrs/day, 365 days/yr
-----------------------------------	-----------------------------------	---

Fuel Usage Data (fill out all applicable fields)

Does this emission unit combust fuel? ___ Yes <u> X </u> No	If yes, is it? ___ Indirect Fired ___ Direct Fired
Maximum design heat input and/or maximum horsepower rating:	Type and Btu/hr rating of burners:

List the primary fuel type(s) and if applicable, the secondary fuel type(s). For each fuel type listed, provide the maximum hourly and annual fuel usage for each.

Describe each fuel expected to be used during the term of the permit.

Fuel Type	Max. Sulfur Content	Max. Ash Content	BTU Value

Union Carbide Corporation South Charleston Facility – Chemical Mixing Plant

<i>Emissions Data</i>		
Criteria Pollutants	Potential Emissions	
	PPH	TPY
Carbon Monoxide (CO)		
Nitrogen Oxides (NO _x)		
Lead (Pb)		
Particulate Matter (PM _{2.5})		
Particulate Matter (PM ₁₀)		
Total Particulate Matter (TSP)		
Sulfur Dioxide (SO ₂)		
Volatile Organic Compounds (VOC)		
Hazardous Air Pollutants	Potential Emissions	
	PPH	TPY
Regulated Pollutants other than Criteria and HAP	Potential Emissions	
	PPH	TPY

List the method(s) used to calculate the potential emissions (include dates of any stack tests conducted, versions of software used, source and dates of emission factors, etc.).

Applicable Requirements

List all applicable requirements for this emission unit. For each applicable requirement, include the underlying rule/regulation citation and/or construction permit with the condition number. (Note: Title V permit condition numbers alone are not the underlying applicable requirements). If an emission limit is calculated based on the type of source and design capacity or if a standard is based on a design parameter, this information should also be included.

See Attachment I for applicable requirements, monitoring, recordkeeping, reporting and testing from existing Title V permit.

X Permit Shield

For all applicable requirements listed above, provide monitoring/testing/recordkeeping/reporting which shall be used to demonstrate compliance. If the method is based on a permit or rule, include the condition number or citation. (Note: Each requirement listed above must have an associated method of demonstrating compliance. If there is not already a required method in place, then a method must be proposed.)

See Attachment I for applicable requirements, monitoring, recordkeeping, reporting and testing from existing Title V permit.

Are you in compliance with all applicable requirements for this emission unit? X Yes No

If no, complete the **Schedule of Compliance Form** as **ATTACHMENT F**.

ATTACHMENT E - Emission Unit Form

Emission Unit Description: Storage Tank

Emission unit ID number: 2005	Emission unit name: Tank 2005	List any control devices associated with this emission unit:
---	---	---

Provide a description of the emission unit (type, method of operation, design parameters, etc.):

Storage of volatile organic liquid

Manufacturer:	Model number:	Serial number:
Construction date: See Attachment D Equipment Table	Installation date: See Attachment D Equipment Table	Modification date(s): See Attachment D Equipment Table

Design Capacity (examples: furnaces - tons/hr, tanks - gallons): See Attachment D Equipment Table

Maximum Hourly Throughput:	Maximum Annual Throughput:	Maximum Operating Schedule: 24 hrs/day, 365 days/yr
-----------------------------------	-----------------------------------	---

Fuel Usage Data (fill out all applicable fields)

Does this emission unit combust fuel? ___Yes <u>X</u> No	If yes, is it? ___ Indirect Fired ___ Direct Fired
Maximum design heat input and/or maximum horsepower rating:	Type and Btu/hr rating of burners:

List the primary fuel type(s) and if applicable, the secondary fuel type(s). For each fuel type listed, provide the maximum hourly and annual fuel usage for each.

Describe each fuel expected to be used during the term of the permit.

Fuel Type	Max. Sulfur Content	Max. Ash Content	BTU Value

Union Carbide Corporation South Charleston Facility – Chemical Mixing Plant

<i>Emissions Data</i>		
Criteria Pollutants	Potential Emissions	
	PPH	TPY
Carbon Monoxide (CO)		
Nitrogen Oxides (NO _x)		
Lead (Pb)		
Particulate Matter (PM _{2.5})		
Particulate Matter (PM ₁₀)		
Total Particulate Matter (TSP)		
Sulfur Dioxide (SO ₂)		
Volatile Organic Compounds (VOC)		
Hazardous Air Pollutants	Potential Emissions	
	PPH	TPY
Regulated Pollutants other than Criteria and HAP	Potential Emissions	
	PPH	TPY

List the method(s) used to calculate the potential emissions (include dates of any stack tests conducted, versions of software used, source and dates of emission factors, etc.).

Applicable Requirements

List all applicable requirements for this emission unit. For each applicable requirement, include the underlying rule/regulation citation and/or construction permit with the condition number. (Note: Title V permit condition numbers alone are not the underlying applicable requirements). If an emission limit is calculated based on the type of source and design capacity or if a standard is based on a design parameter, this information should also be included.

See Attachment I for applicable requirements, monitoring, recordkeeping, reporting and testing from existing Title V permit.

X Permit Shield

For all applicable requirements listed above, provide monitoring/testing/recordkeeping/reporting which shall be used to demonstrate compliance. If the method is based on a permit or rule, include the condition number or citation. (Note: Each requirement listed above must have an associated method of demonstrating compliance. If there is not already a required method in place, then a method must be proposed.)

See Attachment I for applicable requirements, monitoring, recordkeeping, reporting and testing from existing Title V permit.

Are you in compliance with all applicable requirements for this emission unit? X Yes No

If no, complete the **Schedule of Compliance Form** as **ATTACHMENT F**.

ATTACHMENT E - Emission Unit Form

Emission Unit Description: Storage Tank

Emission unit ID number: 2009	Emission unit name: Tank 2009	List any control devices associated with this emission unit:
---	---	---

Provide a description of the emission unit (type, method of operation, design parameters, etc.):

Storage of volatile organic liquid

Manufacturer:	Model number:	Serial number:
Construction date: See Attachment D Equipment Table	Installation date: See Attachment D Equipment Table	Modification date(s): See Attachment D Equipment Table

Design Capacity (examples: furnaces - tons/hr, tanks - gallons): See Attachment D Equipment Table

Maximum Hourly Throughput:	Maximum Annual Throughput:	Maximum Operating Schedule: 24 hrs/day, 365 days/yr
-----------------------------------	-----------------------------------	---

Fuel Usage Data (fill out all applicable fields)

Does this emission unit combust fuel? ___Yes <u>X</u> No	If yes, is it? ___ Indirect Fired ___ Direct Fired
Maximum design heat input and/or maximum horsepower rating:	Type and Btu/hr rating of burners:

List the primary fuel type(s) and if applicable, the secondary fuel type(s). For each fuel type listed, provide the maximum hourly and annual fuel usage for each.

Describe each fuel expected to be used during the term of the permit.

Fuel Type	Max. Sulfur Content	Max. Ash Content	BTU Value

Union Carbide Corporation South Charleston Facility – Chemical Mixing Plant

<i>Emissions Data</i>		
Criteria Pollutants	Potential Emissions	
	PPH	TPY
Carbon Monoxide (CO)		
Nitrogen Oxides (NO _x)		
Lead (Pb)		
Particulate Matter (PM _{2.5})		
Particulate Matter (PM ₁₀)		
Total Particulate Matter (TSP)		
Sulfur Dioxide (SO ₂)		
Volatile Organic Compounds (VOC)		
Hazardous Air Pollutants	Potential Emissions	
	PPH	TPY
Regulated Pollutants other than Criteria and HAP	Potential Emissions	
	PPH	TPY

List the method(s) used to calculate the potential emissions (include dates of any stack tests conducted, versions of software used, source and dates of emission factors, etc.).

Applicable Requirements

List all applicable requirements for this emission unit. For each applicable requirement, include the underlying rule/regulation citation and/or construction permit with the condition number. (Note: Title V permit condition numbers alone are not the underlying applicable requirements). If an emission limit is calculated based on the type of source and design capacity or if a standard is based on a design parameter, this information should also be included.

See Attachment I for applicable requirements, monitoring, recordkeeping, reporting and testing from existing Title V permit.

X Permit Shield

For all applicable requirements listed above, provide monitoring/testing/recordkeeping/reporting which shall be used to demonstrate compliance. If the method is based on a permit or rule, include the condition number or citation. (Note: Each requirement listed above must have an associated method of demonstrating compliance. If there is not already a required method in place, then a method must be proposed.)

See Attachment I for applicable requirements, monitoring, recordkeeping, reporting and testing from existing Title V permit.

Are you in compliance with all applicable requirements for this emission unit? X Yes No

If no, complete the **Schedule of Compliance Form** as **ATTACHMENT F**.

ATTACHMENT E - Emission Unit Form

Emission Unit Description: Storage Tank

Emission unit ID number: 2012	Emission unit name: Tank 2012	List any control devices associated with this emission unit:
---	---	---

Provide a description of the emission unit (type, method of operation, design parameters, etc.):

Storage of volatile organic liquid

Manufacturer:	Model number:	Serial number:
Construction date: See Attachment D Equipment Table	Installation date: See Attachment D Equipment Table	Modification date(s): See Attachment D Equipment Table

Design Capacity (examples: furnaces - tons/hr, tanks - gallons): See Attachment D Equipment Table

Maximum Hourly Throughput:	Maximum Annual Throughput:	Maximum Operating Schedule: 24 hrs/day, 365 days/yr
-----------------------------------	-----------------------------------	---

Fuel Usage Data (fill out all applicable fields)

Does this emission unit combust fuel? ___Yes <u>X</u> No	If yes, is it? ___ Indirect Fired ___ Direct Fired
Maximum design heat input and/or maximum horsepower rating:	Type and Btu/hr rating of burners:

List the primary fuel type(s) and if applicable, the secondary fuel type(s). For each fuel type listed, provide the maximum hourly and annual fuel usage for each.

Describe each fuel expected to be used during the term of the permit.

Fuel Type	Max. Sulfur Content	Max. Ash Content	BTU Value

Union Carbide Corporation South Charleston Facility – Chemical Mixing Plant

<i>Emissions Data</i>		
Criteria Pollutants	Potential Emissions	
	PPH	TPY
Carbon Monoxide (CO)		
Nitrogen Oxides (NO _x)		
Lead (Pb)		
Particulate Matter (PM _{2.5})		
Particulate Matter (PM ₁₀)		
Total Particulate Matter (TSP)		
Sulfur Dioxide (SO ₂)		
Volatile Organic Compounds (VOC)		
Hazardous Air Pollutants	Potential Emissions	
	PPH	TPY
Regulated Pollutants other than Criteria and HAP	Potential Emissions	
	PPH	TPY

List the method(s) used to calculate the potential emissions (include dates of any stack tests conducted, versions of software used, source and dates of emission factors, etc.).

Applicable Requirements

List all applicable requirements for this emission unit. For each applicable requirement, include the underlying rule/regulation citation and/or construction permit with the condition number. (Note: Title V permit condition numbers alone are not the underlying applicable requirements). If an emission limit is calculated based on the type of source and design capacity or if a standard is based on a design parameter, this information should also be included.

See Attachment I for applicable requirements, monitoring, recordkeeping, reporting and testing from existing Title V permit.

X Permit Shield

For all applicable requirements listed above, provide monitoring/testing/recordkeeping/reporting which shall be used to demonstrate compliance. If the method is based on a permit or rule, include the condition number or citation. (Note: Each requirement listed above must have an associated method of demonstrating compliance. If there is not already a required method in place, then a method must be proposed.)

See Attachment I for applicable requirements, monitoring, recordkeeping, reporting and testing from existing Title V permit.

Are you in compliance with all applicable requirements for this emission unit? X Yes No

If no, complete the **Schedule of Compliance Form** as **ATTACHMENT F**.

ATTACHMENT E - Emission Unit Form

Emission Unit Description: Storage Tank

Emission unit ID number: 2011	Emission unit name: Tank 2011	List any control devices associated with this emission unit:
---	---	---

Provide a description of the emission unit (type, method of operation, design parameters, etc.):

Storage of volatile organic liquid

Manufacturer:	Model number:	Serial number:
Construction date: See Attachment D Equipment Table	Installation date: See Attachment D Equipment Table	Modification date(s): See Attachment D Equipment Table

Design Capacity (examples: furnaces - tons/hr, tanks - gallons): See Attachment D Equipment Table

Maximum Hourly Throughput:	Maximum Annual Throughput:	Maximum Operating Schedule: 24 hrs/day, 365 days/yr
-----------------------------------	-----------------------------------	---

Fuel Usage Data (fill out all applicable fields)

Does this emission unit combust fuel? ___Yes <u>X</u> No	If yes, is it? ___ Indirect Fired ___ Direct Fired
Maximum design heat input and/or maximum horsepower rating:	Type and Btu/hr rating of burners:

List the primary fuel type(s) and if applicable, the secondary fuel type(s). For each fuel type listed, provide the maximum hourly and annual fuel usage for each.

Describe each fuel expected to be used during the term of the permit.

Fuel Type	Max. Sulfur Content	Max. Ash Content	BTU Value

Union Carbide Corporation South Charleston Facility – Chemical Mixing Plant

<i>Emissions Data</i>		
Criteria Pollutants	Potential Emissions	
	PPH	TPY
Carbon Monoxide (CO)		
Nitrogen Oxides (NO _x)		
Lead (Pb)		
Particulate Matter (PM _{2.5})		
Particulate Matter (PM ₁₀)		
Total Particulate Matter (TSP)		
Sulfur Dioxide (SO ₂)		
Volatile Organic Compounds (VOC)		
Hazardous Air Pollutants	Potential Emissions	
	PPH	TPY
Regulated Pollutants other than Criteria and HAP	Potential Emissions	
	PPH	TPY

List the method(s) used to calculate the potential emissions (include dates of any stack tests conducted, versions of software used, source and dates of emission factors, etc.).

Applicable Requirements

List all applicable requirements for this emission unit. For each applicable requirement, include the underlying rule/regulation citation and/or construction permit with the condition number. (Note: Title V permit condition numbers alone are not the underlying applicable requirements). If an emission limit is calculated based on the type of source and design capacity or if a standard is based on a design parameter, this information should also be included.

See Attachment I for applicable requirements, monitoring, recordkeeping, reporting and testing from existing Title V permit.

X Permit Shield

For all applicable requirements listed above, provide monitoring/testing/recordkeeping/reporting which shall be used to demonstrate compliance. If the method is based on a permit or rule, include the condition number or citation. (Note: Each requirement listed above must have an associated method of demonstrating compliance. If there is not already a required method in place, then a method must be proposed.)

See Attachment I for applicable requirements, monitoring, recordkeeping, reporting and testing from existing Title V permit.

Are you in compliance with all applicable requirements for this emission unit? X Yes No

If no, complete the **Schedule of Compliance Form** as **ATTACHMENT F**.

ATTACHMENT E - Emission Unit Form

Emission Unit Description: Storage Tank

Emission unit ID number: 2010	Emission unit name: Tank 2010	List any control devices associated with this emission unit:
---	---	---

Provide a description of the emission unit (type, method of operation, design parameters, etc.):

Storage of volatile organic liquid

Manufacturer:	Model number:	Serial number:
Construction date: See Attachment D Equipment Table	Installation date: See Attachment D Equipment Table	Modification date(s): See Attachment D Equipment Table

Design Capacity (examples: furnaces - tons/hr, tanks - gallons): See Attachment D Equipment Table

Maximum Hourly Throughput:	Maximum Annual Throughput:	Maximum Operating Schedule: 24 hrs/day, 365 days/yr
-----------------------------------	-----------------------------------	---

Fuel Usage Data (fill out all applicable fields)

Does this emission unit combust fuel? ___Yes <u>X</u> No	If yes, is it? ___ Indirect Fired ___ Direct Fired
Maximum design heat input and/or maximum horsepower rating:	Type and Btu/hr rating of burners:

List the primary fuel type(s) and if applicable, the secondary fuel type(s). For each fuel type listed, provide the maximum hourly and annual fuel usage for each.

Describe each fuel expected to be used during the term of the permit.

Fuel Type	Max. Sulfur Content	Max. Ash Content	BTU Value

Union Carbide Corporation South Charleston Facility – Chemical Mixing Plant

<i>Emissions Data</i>		
Criteria Pollutants	Potential Emissions	
	PPH	TPY
Carbon Monoxide (CO)		
Nitrogen Oxides (NO _x)		
Lead (Pb)		
Particulate Matter (PM _{2.5})		
Particulate Matter (PM ₁₀)		
Total Particulate Matter (TSP)		
Sulfur Dioxide (SO ₂)		
Volatile Organic Compounds (VOC)		
Hazardous Air Pollutants	Potential Emissions	
	PPH	TPY
Regulated Pollutants other than Criteria and HAP	Potential Emissions	
	PPH	TPY

List the method(s) used to calculate the potential emissions (include dates of any stack tests conducted, versions of software used, source and dates of emission factors, etc.).

Applicable Requirements

List all applicable requirements for this emission unit. For each applicable requirement, include the underlying rule/regulation citation and/or construction permit with the condition number. (Note: Title V permit condition numbers alone are not the underlying applicable requirements). If an emission limit is calculated based on the type of source and design capacity or if a standard is based on a design parameter, this information should also be included.

See Attachment I for applicable requirements, monitoring, recordkeeping, reporting and testing from existing Title V permit.

X Permit Shield

For all applicable requirements listed above, provide monitoring/testing/recordkeeping/reporting which shall be used to demonstrate compliance. If the method is based on a permit or rule, include the condition number or citation. (Note: Each requirement listed above must have an associated method of demonstrating compliance. If there is not already a required method in place, then a method must be proposed.)

See Attachment I for applicable requirements, monitoring, recordkeeping, reporting and testing from existing Title V permit.

Are you in compliance with all applicable requirements for this emission unit? X Yes No

If no, complete the **Schedule of Compliance Form** as **ATTACHMENT F**.

ATTACHMENT E - Emission Unit Form

Emission Unit Description: Storage Tank

Emission unit ID number: 2014	Emission unit name: Tank 2014	List any control devices associated with this emission unit:
---	---	---

Provide a description of the emission unit (type, method of operation, design parameters, etc.):

Storage of volatile organic liquid

Manufacturer:	Model number:	Serial number:
Construction date: See Attachment D Equipment Table	Installation date: See Attachment D Equipment Table	Modification date(s): See Attachment D Equipment Table

Design Capacity (examples: furnaces - tons/hr, tanks - gallons): See Attachment D Equipment Table

Maximum Hourly Throughput:	Maximum Annual Throughput:	Maximum Operating Schedule: 24 hrs/day, 365 days/yr
-----------------------------------	-----------------------------------	---

Fuel Usage Data (fill out all applicable fields)

Does this emission unit combust fuel? ___ Yes <u> X </u> No	If yes, is it? ___ Indirect Fired ___ Direct Fired
Maximum design heat input and/or maximum horsepower rating:	Type and Btu/hr rating of burners:

List the primary fuel type(s) and if applicable, the secondary fuel type(s). For each fuel type listed, provide the maximum hourly and annual fuel usage for each.

Describe each fuel expected to be used during the term of the permit.

Fuel Type	Max. Sulfur Content	Max. Ash Content	BTU Value

Union Carbide Corporation South Charleston Facility – Chemical Mixing Plant

<i>Emissions Data</i>		
Criteria Pollutants	Potential Emissions	
	PPH	TPY
Carbon Monoxide (CO)		
Nitrogen Oxides (NO _x)		
Lead (Pb)		
Particulate Matter (PM _{2.5})		
Particulate Matter (PM ₁₀)		
Total Particulate Matter (TSP)		
Sulfur Dioxide (SO ₂)		
Volatile Organic Compounds (VOC)		
Hazardous Air Pollutants	Potential Emissions	
	PPH	TPY
Regulated Pollutants other than Criteria and HAP	Potential Emissions	
	PPH	TPY

List the method(s) used to calculate the potential emissions (include dates of any stack tests conducted, versions of software used, source and dates of emission factors, etc.).

Applicable Requirements

List all applicable requirements for this emission unit. For each applicable requirement, include the underlying rule/regulation citation and/or construction permit with the condition number. (Note: Title V permit condition numbers alone are not the underlying applicable requirements). If an emission limit is calculated based on the type of source and design capacity or if a standard is based on a design parameter, this information should also be included.

See Attachment I for applicable requirements, monitoring, recordkeeping, reporting and testing from existing Title V permit.

X Permit Shield

For all applicable requirements listed above, provide monitoring/testing/recordkeeping/reporting which shall be used to demonstrate compliance. If the method is based on a permit or rule, include the condition number or citation. (Note: Each requirement listed above must have an associated method of demonstrating compliance. If there is not already a required method in place, then a method must be proposed.)

See Attachment I for applicable requirements, monitoring, recordkeeping, reporting and testing from existing Title V permit.

Are you in compliance with all applicable requirements for this emission unit? X Yes No

If no, complete the **Schedule of Compliance Form** as **ATTACHMENT F**.

ATTACHMENT E - Emission Unit Form

Emission Unit Description: Storage Tank

Emission unit ID number: 2016	Emission unit name: Tank 2016	List any control devices associated with this emission unit:
---	---	---

Provide a description of the emission unit (type, method of operation, design parameters, etc.):

Storage of volatile organic liquid

Manufacturer:	Model number:	Serial number:
Construction date: See Attachment D Equipment Table	Installation date: See Attachment D Equipment Table	Modification date(s): See Attachment D Equipment Table

Design Capacity (examples: furnaces - tons/hr, tanks - gallons): See Attachment D Equipment Table

Maximum Hourly Throughput:	Maximum Annual Throughput:	Maximum Operating Schedule: 24 hrs/day, 365 days/yr
-----------------------------------	-----------------------------------	---

Fuel Usage Data (fill out all applicable fields)

Does this emission unit combust fuel? ___Yes <u>X</u> No	If yes, is it? ___ Indirect Fired ___ Direct Fired
Maximum design heat input and/or maximum horsepower rating:	Type and Btu/hr rating of burners:

List the primary fuel type(s) and if applicable, the secondary fuel type(s). For each fuel type listed, provide the maximum hourly and annual fuel usage for each.

Describe each fuel expected to be used during the term of the permit.

Fuel Type	Max. Sulfur Content	Max. Ash Content	BTU Value

Union Carbide Corporation South Charleston Facility – Chemical Mixing Plant

<i>Emissions Data</i>		
Criteria Pollutants	Potential Emissions	
	PPH	TPY
Carbon Monoxide (CO)		
Nitrogen Oxides (NO _x)		
Lead (Pb)		
Particulate Matter (PM _{2.5})		
Particulate Matter (PM ₁₀)		
Total Particulate Matter (TSP)		
Sulfur Dioxide (SO ₂)		
Volatile Organic Compounds (VOC)		
Hazardous Air Pollutants	Potential Emissions	
	PPH	TPY
Regulated Pollutants other than Criteria and HAP	Potential Emissions	
	PPH	TPY

List the method(s) used to calculate the potential emissions (include dates of any stack tests conducted, versions of software used, source and dates of emission factors, etc.).

Applicable Requirements

List all applicable requirements for this emission unit. For each applicable requirement, include the underlying rule/regulation citation and/or construction permit with the condition number. (Note: Title V permit condition numbers alone are not the underlying applicable requirements). If an emission limit is calculated based on the type of source and design capacity or if a standard is based on a design parameter, this information should also be included.

See Attachment I for applicable requirements, monitoring, recordkeeping, reporting and testing from existing Title V permit.

X Permit Shield

For all applicable requirements listed above, provide monitoring/testing/recordkeeping/reporting which shall be used to demonstrate compliance. If the method is based on a permit or rule, include the condition number or citation. (Note: Each requirement listed above must have an associated method of demonstrating compliance. If there is not already a required method in place, then a method must be proposed.)

See Attachment I for applicable requirements, monitoring, recordkeeping, reporting and testing from existing Title V permit.

Are you in compliance with all applicable requirements for this emission unit? X Yes No

If no, complete the **Schedule of Compliance Form** as **ATTACHMENT F**.

ATTACHMENT E - Emission Unit Form

Emission Unit Description: Storage Tank

Emission unit ID number: 2020	Emission unit name: Tank 2020	List any control devices associated with this emission unit:
---	---	---

Provide a description of the emission unit (type, method of operation, design parameters, etc.):

Storage of volatile organic liquid

Manufacturer:	Model number:	Serial number:
Construction date: See Attachment D Equipment Table	Installation date: See Attachment D Equipment Table	Modification date(s): See Attachment D Equipment Table

Design Capacity (examples: furnaces - tons/hr, tanks - gallons): See Attachment D Equipment Table

Maximum Hourly Throughput:	Maximum Annual Throughput:	Maximum Operating Schedule: 24 hrs/day, 365 days/yr
-----------------------------------	-----------------------------------	---

Fuel Usage Data (fill out all applicable fields)

Does this emission unit combust fuel? ___ Yes <u> X </u> No	If yes, is it? ___ Indirect Fired ___ Direct Fired
Maximum design heat input and/or maximum horsepower rating:	Type and Btu/hr rating of burners:

List the primary fuel type(s) and if applicable, the secondary fuel type(s). For each fuel type listed, provide the maximum hourly and annual fuel usage for each.

Describe each fuel expected to be used during the term of the permit.

Fuel Type	Max. Sulfur Content	Max. Ash Content	BTU Value

Union Carbide Corporation South Charleston Facility – Chemical Mixing Plant

Emissions Data		
Criteria Pollutants	Potential Emissions	
	PPH	TPY
Carbon Monoxide (CO)		
Nitrogen Oxides (NO _x)		
Lead (Pb)		
Particulate Matter (PM _{2.5})		
Particulate Matter (PM ₁₀)		
Total Particulate Matter (TSP)		
Sulfur Dioxide (SO ₂)		
Volatile Organic Compounds (VOC)		
Hazardous Air Pollutants	Potential Emissions	
	PPH	TPY
Regulated Pollutants other than Criteria and HAP	Potential Emissions	
	PPH	TPY

List the method(s) used to calculate the potential emissions (include dates of any stack tests conducted, versions of software used, source and dates of emission factors, etc.).

Applicable Requirements

List all applicable requirements for this emission unit. For each applicable requirement, include the underlying rule/regulation citation and/or construction permit with the condition number. (Note: Title V permit condition numbers alone are not the underlying applicable requirements). If an emission limit is calculated based on the type of source and design capacity or if a standard is based on a design parameter, this information should also be included.

See Attachment I for applicable requirements, monitoring, recordkeeping, reporting and testing from existing Title V permit.

X Permit Shield

For all applicable requirements listed above, provide monitoring/testing/recordkeeping/reporting which shall be used to demonstrate compliance. If the method is based on a permit or rule, include the condition number or citation. (Note: Each requirement listed above must have an associated method of demonstrating compliance. If there is not already a required method in place, then a method must be proposed.)

See Attachment I for applicable requirements, monitoring, recordkeeping, reporting and testing from existing Title V permit.

Are you in compliance with all applicable requirements for this emission unit? X Yes No

If no, complete the **Schedule of Compliance Form** as ATTACHMENT F.

ATTACHMENT E - Emission Unit Form

Emission Unit Description: Storage Tank

Emission unit ID number: 2019	Emission unit name: Tank 2019	List any control devices associated with this emission unit:
---	---	---

Provide a description of the emission unit (type, method of operation, design parameters, etc.):

Storage of volatile organic liquid

Manufacturer:	Model number:	Serial number:
Construction date: See Attachment D Equipment Table	Installation date: See Attachment D Equipment Table	Modification date(s): See Attachment D Equipment Table

Design Capacity (examples: furnaces - tons/hr, tanks - gallons): See Attachment D Equipment Table

Maximum Hourly Throughput:	Maximum Annual Throughput:	Maximum Operating Schedule: 24 hrs/day, 365 days/yr
-----------------------------------	-----------------------------------	---

Fuel Usage Data (fill out all applicable fields)

Does this emission unit combust fuel? ___Yes <u>X</u> No	If yes, is it? ___ Indirect Fired ___ Direct Fired
Maximum design heat input and/or maximum horsepower rating:	Type and Btu/hr rating of burners:

List the primary fuel type(s) and if applicable, the secondary fuel type(s). For each fuel type listed, provide the maximum hourly and annual fuel usage for each.

Describe each fuel expected to be used during the term of the permit.

Fuel Type	Max. Sulfur Content	Max. Ash Content	BTU Value

Union Carbide Corporation South Charleston Facility – Chemical Mixing Plant

<i>Emissions Data</i>		
Criteria Pollutants	Potential Emissions	
	PPH	TPY
Carbon Monoxide (CO)		
Nitrogen Oxides (NO _x)		
Lead (Pb)		
Particulate Matter (PM _{2.5})		
Particulate Matter (PM ₁₀)		
Total Particulate Matter (TSP)		
Sulfur Dioxide (SO ₂)		
Volatile Organic Compounds (VOC)		
Hazardous Air Pollutants	Potential Emissions	
	PPH	TPY
Regulated Pollutants other than Criteria and HAP	Potential Emissions	
	PPH	TPY

List the method(s) used to calculate the potential emissions (include dates of any stack tests conducted, versions of software used, source and dates of emission factors, etc.).

Applicable Requirements

List all applicable requirements for this emission unit. For each applicable requirement, include the underlying rule/regulation citation and/or construction permit with the condition number. (Note: Title V permit condition numbers alone are not the underlying applicable requirements). If an emission limit is calculated based on the type of source and design capacity or if a standard is based on a design parameter, this information should also be included.

See Attachment I for applicable requirements, monitoring, recordkeeping, reporting and testing from existing Title V permit.

X Permit Shield

For all applicable requirements listed above, provide monitoring/testing/recordkeeping/reporting which shall be used to demonstrate compliance. If the method is based on a permit or rule, include the condition number or citation. (Note: Each requirement listed above must have an associated method of demonstrating compliance. If there is not already a required method in place, then a method must be proposed.)

See Attachment I for applicable requirements, monitoring, recordkeeping, reporting and testing from existing Title V permit.

Are you in compliance with all applicable requirements for this emission unit? X Yes No

If no, complete the **Schedule of Compliance Form** as **ATTACHMENT F**.

ATTACHMENT E - Emission Unit Form

Emission Unit Description: Storage Tank

Emission unit ID number: 2018	Emission unit name: Tank 2018	List any control devices associated with this emission unit:
---	---	---

Provide a description of the emission unit (type, method of operation, design parameters, etc.):

Storage of volatile organic liquid

Manufacturer:	Model number:	Serial number:
Construction date: See Attachment D Equipment Table	Installation date: See Attachment D Equipment Table	Modification date(s): See Attachment D Equipment Table

Design Capacity (examples: furnaces - tons/hr, tanks - gallons): See Attachment D Equipment Table

Maximum Hourly Throughput:	Maximum Annual Throughput:	Maximum Operating Schedule: 24 hrs/day, 365 days/yr
-----------------------------------	-----------------------------------	---

Fuel Usage Data (fill out all applicable fields)

Does this emission unit combust fuel? ___ Yes <u> X </u> No	If yes, is it? ___ Indirect Fired ___ Direct Fired
Maximum design heat input and/or maximum horsepower rating:	Type and Btu/hr rating of burners:

List the primary fuel type(s) and if applicable, the secondary fuel type(s). For each fuel type listed, provide the maximum hourly and annual fuel usage for each.

Describe each fuel expected to be used during the term of the permit.

Fuel Type	Max. Sulfur Content	Max. Ash Content	BTU Value

Union Carbide Corporation South Charleston Facility – Chemical Mixing Plant

Emissions Data		
Criteria Pollutants	Potential Emissions	
	PPH	TPY
Carbon Monoxide (CO)		
Nitrogen Oxides (NO _x)		
Lead (Pb)		
Particulate Matter (PM _{2.5})		
Particulate Matter (PM ₁₀)		
Total Particulate Matter (TSP)		
Sulfur Dioxide (SO ₂)		
Volatile Organic Compounds (VOC)		
Hazardous Air Pollutants	Potential Emissions	
	PPH	TPY
Regulated Pollutants other than Criteria and HAP	Potential Emissions	
	PPH	TPY

List the method(s) used to calculate the potential emissions (include dates of any stack tests conducted, versions of software used, source and dates of emission factors, etc.).

Applicable Requirements

List all applicable requirements for this emission unit. For each applicable requirement, include the underlying rule/regulation citation and/or construction permit with the condition number. (Note: Title V permit condition numbers alone are not the underlying applicable requirements). If an emission limit is calculated based on the type of source and design capacity or if a standard is based on a design parameter, this information should also be included.

See Attachment I for applicable requirements, monitoring, recordkeeping, reporting and testing from existing Title V permit.

Permit Shield

For all applicable requirements listed above, provide monitoring/testing/recordkeeping/reporting which shall be used to demonstrate compliance. If the method is based on a permit or rule, include the condition number or citation. (Note: Each requirement listed above must have an associated method of demonstrating compliance. If there is not already a required method in place, then a method must be proposed.)

See Attachment I for applicable requirements, monitoring, recordkeeping, reporting and testing from existing Title V permit.

Are you in compliance with all applicable requirements for this emission unit? Yes No

If no, complete the **Schedule of Compliance Form** as ATTACHMENT F.

ATTACHMENT E - Emission Unit Form

Emission Unit Description: Storage Tank

Emission unit ID number: 2017	Emission unit name: Tank 2017	List any control devices associated with this emission unit:
---	---	---

Provide a description of the emission unit (type, method of operation, design parameters, etc.):

Storage of volatile organic liquid

Manufacturer:	Model number:	Serial number:
Construction date: See Attachment D Equipment Table	Installation date: See Attachment D Equipment Table	Modification date(s): See Attachment D Equipment Table

Design Capacity (examples: furnaces - tons/hr, tanks - gallons): See Attachment D Equipment Table

Maximum Hourly Throughput:	Maximum Annual Throughput:	Maximum Operating Schedule: 24 hrs/day, 365 days/yr
-----------------------------------	-----------------------------------	---

Fuel Usage Data (fill out all applicable fields)

Does this emission unit combust fuel? ___Yes <u>X</u> No	If yes, is it? ___ Indirect Fired ___ Direct Fired
Maximum design heat input and/or maximum horsepower rating:	Type and Btu/hr rating of burners:

List the primary fuel type(s) and if applicable, the secondary fuel type(s). For each fuel type listed, provide the maximum hourly and annual fuel usage for each.

Describe each fuel expected to be used during the term of the permit.

Fuel Type	Max. Sulfur Content	Max. Ash Content	BTU Value

Union Carbide Corporation South Charleston Facility – Chemical Mixing Plant

Emissions Data		
Criteria Pollutants	Potential Emissions	
	PPH	TPY
Carbon Monoxide (CO)		
Nitrogen Oxides (NO _x)		
Lead (Pb)		
Particulate Matter (PM _{2.5})		
Particulate Matter (PM ₁₀)		
Total Particulate Matter (TSP)		
Sulfur Dioxide (SO ₂)		
Volatile Organic Compounds (VOC)		
Hazardous Air Pollutants	Potential Emissions	
	PPH	TPY
Regulated Pollutants other than Criteria and HAP	Potential Emissions	
	PPH	TPY

List the method(s) used to calculate the potential emissions (include dates of any stack tests conducted, versions of software used, source and dates of emission factors, etc.).

Applicable Requirements

List all applicable requirements for this emission unit. For each applicable requirement, include the underlying rule/regulation citation and/or construction permit with the condition number. (Note: Title V permit condition numbers alone are not the underlying applicable requirements). If an emission limit is calculated based on the type of source and design capacity or if a standard is based on a design parameter, this information should also be included.

See Attachment I for applicable requirements, monitoring, recordkeeping, reporting and testing from existing Title V permit.

Permit Shield

For all applicable requirements listed above, provide monitoring/testing/recordkeeping/reporting which shall be used to demonstrate compliance. If the method is based on a permit or rule, include the condition number or citation. (Note: Each requirement listed above must have an associated method of demonstrating compliance. If there is not already a required method in place, then a method must be proposed.)

See Attachment I for applicable requirements, monitoring, recordkeeping, reporting and testing from existing Title V permit.

Are you in compliance with all applicable requirements for this emission unit? Yes No

If no, complete the **Schedule of Compliance Form** as ATTACHMENT F.

ATTACHMENT E - Emission Unit Form

Emission Unit Description: Storage Tank

Emission unit ID number: 2040	Emission unit name: Tank 2040	List any control devices associated with this emission unit:
---	---	---

Provide a description of the emission unit (type, method of operation, design parameters, etc.):

Storage of volatile organic liquid

Manufacturer:	Model number:	Serial number:
Construction date: See Attachment D Equipment Table	Installation date: See Attachment D Equipment Table	Modification date(s): See Attachment D Equipment Table

Design Capacity (examples: furnaces - tons/hr, tanks - gallons): See Attachment D Equipment Table

Maximum Hourly Throughput:	Maximum Annual Throughput:	Maximum Operating Schedule: 24 hrs/day, 365 days/yr
-----------------------------------	-----------------------------------	---

Fuel Usage Data (fill out all applicable fields)

Does this emission unit combust fuel? ___ Yes <u> X </u> No	If yes, is it? ___ Indirect Fired ___ Direct Fired
Maximum design heat input and/or maximum horsepower rating:	Type and Btu/hr rating of burners:

List the primary fuel type(s) and if applicable, the secondary fuel type(s). For each fuel type listed, provide the maximum hourly and annual fuel usage for each.

Describe each fuel expected to be used during the term of the permit.

Fuel Type	Max. Sulfur Content	Max. Ash Content	BTU Value

Union Carbide Corporation South Charleston Facility – Chemical Mixing Plant

<i>Emissions Data</i>		
Criteria Pollutants	Potential Emissions	
	PPH	TPY
Carbon Monoxide (CO)		
Nitrogen Oxides (NO _x)		
Lead (Pb)		
Particulate Matter (PM _{2.5})		
Particulate Matter (PM ₁₀)		
Total Particulate Matter (TSP)		
Sulfur Dioxide (SO ₂)		
Volatile Organic Compounds (VOC)		
Hazardous Air Pollutants	Potential Emissions	
	PPH	TPY
Regulated Pollutants other than Criteria and HAP	Potential Emissions	
	PPH	TPY

List the method(s) used to calculate the potential emissions (include dates of any stack tests conducted, versions of software used, source and dates of emission factors, etc.).

Applicable Requirements

List all applicable requirements for this emission unit. For each applicable requirement, include the underlying rule/regulation citation and/or construction permit with the condition number. (Note: Title V permit condition numbers alone are not the underlying applicable requirements). If an emission limit is calculated based on the type of source and design capacity or if a standard is based on a design parameter, this information should also be included.

See Attachment I for applicable requirements, monitoring, recordkeeping, reporting and testing from existing Title V permit.

X Permit Shield

For all applicable requirements listed above, provide monitoring/testing/recordkeeping/reporting which shall be used to demonstrate compliance. If the method is based on a permit or rule, include the condition number or citation. (Note: Each requirement listed above must have an associated method of demonstrating compliance. If there is not already a required method in place, then a method must be proposed.)

See Attachment I for applicable requirements, monitoring, recordkeeping, reporting and testing from existing Title V permit.

Are you in compliance with all applicable requirements for this emission unit? X Yes No

If no, complete the **Schedule of Compliance Form** as **ATTACHMENT F**.

ATTACHMENT E - Emission Unit Form

Emission Unit Description: Storage Tank

Emission unit ID number: 2043	Emission unit name: Tank 2043	List any control devices associated with this emission unit:
---	---	---

Provide a description of the emission unit (type, method of operation, design parameters, etc.):

Storage of volatile organic liquid

Manufacturer:	Model number:	Serial number:
Construction date: See Attachment D Equipment Table	Installation date: See Attachment D Equipment Table	Modification date(s): See Attachment D Equipment Table

Design Capacity (examples: furnaces - tons/hr, tanks - gallons): See Attachment D Equipment Table

Maximum Hourly Throughput:	Maximum Annual Throughput:	Maximum Operating Schedule: 24 hrs/day, 365 days/yr
-----------------------------------	-----------------------------------	---

Fuel Usage Data (fill out all applicable fields)

Does this emission unit combust fuel? ___ Yes <u> X </u> No	If yes, is it? ___ Indirect Fired ___ Direct Fired
Maximum design heat input and/or maximum horsepower rating:	Type and Btu/hr rating of burners:

List the primary fuel type(s) and if applicable, the secondary fuel type(s). For each fuel type listed, provide the maximum hourly and annual fuel usage for each.

Describe each fuel expected to be used during the term of the permit.

Fuel Type	Max. Sulfur Content	Max. Ash Content	BTU Value

Union Carbide Corporation South Charleston Facility – Chemical Mixing Plant

Emissions Data		
Criteria Pollutants	Potential Emissions	
	PPH	TPY
Carbon Monoxide (CO)		
Nitrogen Oxides (NO _x)		
Lead (Pb)		
Particulate Matter (PM _{2.5})		
Particulate Matter (PM ₁₀)		
Total Particulate Matter (TSP)		
Sulfur Dioxide (SO ₂)		
Volatile Organic Compounds (VOC)		
Hazardous Air Pollutants	Potential Emissions	
	PPH	TPY
Regulated Pollutants other than Criteria and HAP	Potential Emissions	
	PPH	TPY

List the method(s) used to calculate the potential emissions (include dates of any stack tests conducted, versions of software used, source and dates of emission factors, etc.).

Applicable Requirements

List all applicable requirements for this emission unit. For each applicable requirement, include the underlying rule/regulation citation and/or construction permit with the condition number. (Note: Title V permit condition numbers alone are not the underlying applicable requirements). If an emission limit is calculated based on the type of source and design capacity or if a standard is based on a design parameter, this information should also be included.

See Attachment I for applicable requirements, monitoring, recordkeeping, reporting and testing from existing Title V permit.

X Permit Shield

For all applicable requirements listed above, provide monitoring/testing/recordkeeping/reporting which shall be used to demonstrate compliance. If the method is based on a permit or rule, include the condition number or citation. (Note: Each requirement listed above must have an associated method of demonstrating compliance. If there is not already a required method in place, then a method must be proposed.)

See Attachment I for applicable requirements, monitoring, recordkeeping, reporting and testing from existing Title V permit.

Are you in compliance with all applicable requirements for this emission unit? X Yes No

If no, complete the **Schedule of Compliance Form** as **ATTACHMENT F**.

ATTACHMENT E - Emission Unit Form

Emission Unit Description: Storage Tank

Emission unit ID number: 2044	Emission unit name: Tank 2044	List any control devices associated with this emission unit:
---	---	---

Provide a description of the emission unit (type, method of operation, design parameters, etc.):

Storage of volatile organic liquid

Manufacturer:	Model number:	Serial number:
Construction date: See Attachment D Equipment Table	Installation date: See Attachment D Equipment Table	Modification date(s): See Attachment D Equipment Table

Design Capacity (examples: furnaces - tons/hr, tanks - gallons): See Attachment D Equipment Table

Maximum Hourly Throughput:	Maximum Annual Throughput:	Maximum Operating Schedule: 24 hrs/day, 365 days/yr
-----------------------------------	-----------------------------------	---

Fuel Usage Data (fill out all applicable fields)

Does this emission unit combust fuel? ___Yes <u>X</u> No	If yes, is it? ___ Indirect Fired ___ Direct Fired
Maximum design heat input and/or maximum horsepower rating:	Type and Btu/hr rating of burners:

List the primary fuel type(s) and if applicable, the secondary fuel type(s). For each fuel type listed, provide the maximum hourly and annual fuel usage for each.

Describe each fuel expected to be used during the term of the permit.

Fuel Type	Max. Sulfur Content	Max. Ash Content	BTU Value

Union Carbide Corporation South Charleston Facility – Chemical Mixing Plant

<i>Emissions Data</i>		
Criteria Pollutants	Potential Emissions	
	PPH	TPY
Carbon Monoxide (CO)		
Nitrogen Oxides (NO _x)		
Lead (Pb)		
Particulate Matter (PM _{2.5})		
Particulate Matter (PM ₁₀)		
Total Particulate Matter (TSP)		
Sulfur Dioxide (SO ₂)		
Volatile Organic Compounds (VOC)		
Hazardous Air Pollutants	Potential Emissions	
	PPH	TPY
Regulated Pollutants other than Criteria and HAP	Potential Emissions	
	PPH	TPY

List the method(s) used to calculate the potential emissions (include dates of any stack tests conducted, versions of software used, source and dates of emission factors, etc.).

Applicable Requirements

List all applicable requirements for this emission unit. For each applicable requirement, include the underlying rule/regulation citation and/or construction permit with the condition number. (Note: Title V permit condition numbers alone are not the underlying applicable requirements). If an emission limit is calculated based on the type of source and design capacity or if a standard is based on a design parameter, this information should also be included.

See Attachment I for applicable requirements, monitoring, recordkeeping, reporting and testing from existing Title V permit.

Permit Shield

For all applicable requirements listed above, provide monitoring/testing/recordkeeping/reporting which shall be used to demonstrate compliance. If the method is based on a permit or rule, include the condition number or citation. (Note: Each requirement listed above must have an associated method of demonstrating compliance. If there is not already a required method in place, then a method must be proposed.)

See Attachment I for applicable requirements, monitoring, recordkeeping, reporting and testing from existing Title V permit.

Are you in compliance with all applicable requirements for this emission unit? Yes No

If no, complete the **Schedule of Compliance Form** as ATTACHMENT F.

ATTACHMENT E - Emission Unit Form

Emission Unit Description: Storage Tank

Emission unit ID number: 2042	Emission unit name: Tank 2042	List any control devices associated with this emission unit:
---	---	---

Provide a description of the emission unit (type, method of operation, design parameters, etc.):

Storage of volatile organic liquid

Manufacturer:	Model number:	Serial number:
Construction date: See Attachment D Equipment Table	Installation date: See Attachment D Equipment Table	Modification date(s): See Attachment D Equipment Table

Design Capacity (examples: furnaces - tons/hr, tanks - gallons): See Attachment D Equipment Table

Maximum Hourly Throughput:	Maximum Annual Throughput:	Maximum Operating Schedule: 24 hrs/day, 365 days/yr
-----------------------------------	-----------------------------------	---

Fuel Usage Data (fill out all applicable fields)

Does this emission unit combust fuel? ___ Yes <u> X </u> No	If yes, is it? ___ Indirect Fired ___ Direct Fired
Maximum design heat input and/or maximum horsepower rating:	Type and Btu/hr rating of burners:

List the primary fuel type(s) and if applicable, the secondary fuel type(s). For each fuel type listed, provide the maximum hourly and annual fuel usage for each.

Describe each fuel expected to be used during the term of the permit.

Fuel Type	Max. Sulfur Content	Max. Ash Content	BTU Value

Union Carbide Corporation South Charleston Facility – Chemical Mixing Plant

Emissions Data		
Criteria Pollutants	Potential Emissions	
	PPH	TPY
Carbon Monoxide (CO)		
Nitrogen Oxides (NO _x)		
Lead (Pb)		
Particulate Matter (PM _{2.5})		
Particulate Matter (PM ₁₀)		
Total Particulate Matter (TSP)		
Sulfur Dioxide (SO ₂)		
Volatile Organic Compounds (VOC)		
Hazardous Air Pollutants	Potential Emissions	
	PPH	TPY
Regulated Pollutants other than Criteria and HAP	Potential Emissions	
	PPH	TPY

List the method(s) used to calculate the potential emissions (include dates of any stack tests conducted, versions of software used, source and dates of emission factors, etc.).

Applicable Requirements

List all applicable requirements for this emission unit. For each applicable requirement, include the underlying rule/regulation citation and/or construction permit with the condition number. (Note: Title V permit condition numbers alone are not the underlying applicable requirements). If an emission limit is calculated based on the type of source and design capacity or if a standard is based on a design parameter, this information should also be included.

See Attachment I for applicable requirements, monitoring, recordkeeping, reporting and testing from existing Title V permit.

Permit Shield

For all applicable requirements listed above, provide monitoring/testing/recordkeeping/reporting which shall be used to demonstrate compliance. If the method is based on a permit or rule, include the condition number or citation. (Note: Each requirement listed above must have an associated method of demonstrating compliance. If there is not already a required method in place, then a method must be proposed.)

See Attachment I for applicable requirements, monitoring, recordkeeping, reporting and testing from existing Title V permit.

Are you in compliance with all applicable requirements for this emission unit? Yes No

If no, complete the **Schedule of Compliance Form** as **ATTACHMENT F**.

ATTACHMENT E - Emission Unit Form			
Emission Unit Description: <i>Auxiliary Air Compressor</i>			
Emission unit ID number: 004	Emission unit name: A-004	List any control devices associated with this emission unit: N/A	
Provide a description of the emission unit (type, method of operation, design parameters, etc.): Temporary, portable diesel auxiliary air compressor.			
Manufacturer:	Model number:	Serial number:	
Construction date:	Installation date:	Modification date(s):	
Design Capacity (examples: furnaces - tons/hr, tanks - gallons):			
Maximum Hourly Throughput:	Maximum Annual Throughput:	Maximum Operating Schedule:	
Fuel Usage Data (fill out all applicable fields)			
Does this emission unit combust fuel? <input checked="" type="checkbox"/> Yes <input type="checkbox"/> No		If yes, is it? <input type="checkbox"/> Indirect Fired <input type="checkbox"/> Direct Fired	
Maximum design heat input and/or maximum horsepower rating:		Type and Btu/hr rating of burners:	
List the primary fuel type(s) and if applicable, the secondary fuel type(s). For each fuel type listed, provide the maximum hourly and annual fuel usage for each. Diesel Fuel			
Describe each fuel expected to be used during the term of the permit.			
Fuel Type	Max. Sulfur Content	Max. Ash Content	BTU Value
Diesel Fuel			

UCC South Charleston Facility: Energy Systems & Pipelines/Environmental Operations

<i>Emissions Data</i>		
Criteria Pollutants	Potential Emissions	
	PPH	TPY
Carbon Monoxide (CO)		
Nitrogen Oxides (NO _x)		
Lead (Pb)		
Particulate Matter (PM _{2.5})		
Particulate Matter (PM ₁₀)		
Total Particulate Matter (TSP)		
Sulfur Dioxide (SO ₂)		
Volatile Organic Compounds (VOC)		
Hazardous Air Pollutants	Potential Emissions	
	PPH	TPY
Regulated Pollutants other than Criteria and HAP	Potential Emissions	
	PPH	TPY

List the method(s) used to calculate the potential emissions (include dates of any stack tests conducted, versions of software used, source and dates of emission factors, etc.).

Applicable Requirements

List all applicable requirements for this emission unit. For each applicable requirement, include the underlying rule/regulation citation and/or construction permit with the condition number. (Note: Title V permit condition numbers alone are not the underlying applicable requirements). If an emission limit is calculated based on the type of source and design capacity or if a standard is based on a design parameter, this information should also be included.

See Attachment I for applicable requirements, monitoring, recordkeeping, reporting and testing from existing Title V permit.

Permit Shield

For all applicable requirements listed above, provide monitoring/testing/recordkeeping/reporting which shall be used to demonstrate compliance. If the method is based on a permit or rule, include the condition number or citation. (Note: Each requirement listed above must have an associated method of demonstrating compliance. If there is not already a required method in place, then a method must be proposed.)

See Attachment I for applicable requirements, monitoring, recordkeeping, reporting and testing from existing Title V permit.

Are you in compliance with all applicable requirements for this emission unit? Yes No

If no, complete the **Schedule of Compliance Form** as **ATTACHMENT F**.

ATTACHMENT E - Emission Unit Form			
Emission Unit Description: <i>Indirect Heat Exchanger</i>			
Emission unit ID number: B26	Emission unit name: Boiler 26	List any control devices associated with this emission unit: N/A	
Provide a description of the emission unit (type, method of operation, design parameters, etc.): Natural gas-fired boiler.			
Manufacturer:	Model number:	Serial number:	
Construction date: See Attachment D Equipment Table	Installation date: See Attachment D Equipment Table	Modification date(s): See Attachment D Equipment Table	
Design Capacity (examples: furnaces - tons/hr, tanks - gallons): See Attachment D Equipment Table			
Maximum Hourly Throughput:	Maximum Annual Throughput:	Maximum Operating Schedule: 24 hrs/day, 365 days/yr	
Fuel Usage Data (fill out all applicable fields)			
Does this emission unit combust fuel? <input checked="" type="checkbox"/> Yes <input type="checkbox"/> No		If yes, is it? <input type="checkbox"/> Indirect Fired <input type="checkbox"/> Direct Fired	
Maximum design heat input and/or maximum horsepower rating: 352 MM Btu/hr		Type and Btu/hr rating of burners:	
List the primary fuel type(s) and if applicable, the secondary fuel type(s). For each fuel type listed, provide the maximum hourly and annual fuel usage for each. Natural Gas			
Describe each fuel expected to be used during the term of the permit.			
Fuel Type	Max. Sulfur Content	Max. Ash Content	BTU Value
Natural Gas			

UCC South Charleston Facility: Energy Systems & Pipelines/Environmental Operations

<i>Emissions Data</i>		
Criteria Pollutants	Potential Emissions	
	PPH	TPY
Carbon Monoxide (CO)		
Nitrogen Oxides (NO _x)		
Lead (Pb)		
Particulate Matter (PM _{2.5})		
Particulate Matter (PM ₁₀)		
Total Particulate Matter (TSP)		
Sulfur Dioxide (SO ₂)		
Volatile Organic Compounds (VOC)		
Hazardous Air Pollutants	Potential Emissions	
	PPH	TPY
Regulated Pollutants other than Criteria and HAP	Potential Emissions	
	PPH	TPY

List the method(s) used to calculate the potential emissions (include dates of any stack tests conducted, versions of software used, source and dates of emission factors, etc.).

Applicable Requirements

List all applicable requirements for this emission unit. For each applicable requirement, include the underlying rule/regulation citation and/or construction permit with the condition number. (Note: Title V permit condition numbers alone are not the underlying applicable requirements). If an emission limit is calculated based on the type of source and design capacity or if a standard is based on a design parameter, this information should also be included.

See Attachment I for applicable requirements, monitoring, recordkeeping, reporting and testing from existing Title V permit.

____ Permit Shield

For all applicable requirements listed above, provide monitoring/testing/recordkeeping/reporting which shall be used to demonstrate compliance. If the method is based on a permit or rule, include the condition number or citation. (Note: Each requirement listed above must have an associated method of demonstrating compliance. If there is not already a required method in place, then a method must be proposed.)

See Attachment I for applicable requirements, monitoring, recordkeeping, reporting and testing from existing Title V permit.

Are you in compliance with all applicable requirements for this emission unit? Yes No

If no, complete the **Schedule of Compliance Form** as **ATTACHMENT F**.

ATTACHMENT E - Emission Unit Form			
Emission Unit Description: <i>Indirect Heat Exchanger</i>			
Emission unit ID number: B27	Emission unit name: Boiler 27	List any control devices associated with this emission unit: N/A	
Provide a description of the emission unit (type, method of operation, design parameters, etc.): Natural gas fired boiler equipped to burn process vent gases.			
Manufacturer:	Model number:	Serial number:	
Construction date: See Attachment D Equipment Table	Installation date: See Attachment D Equipment Table	Modification date(s): See Attachment D Equipment Table	
Design Capacity (examples: furnaces - tons/hr, tanks - gallons): See Attachment D Equipment Table			
Maximum Hourly Throughput:	Maximum Annual Throughput:	Maximum Operating Schedule: 24 hrs/day, 365 days/yr	
Fuel Usage Data (fill out all applicable fields)			
Does this emission unit combust fuel? <input checked="" type="checkbox"/> Yes <input type="checkbox"/> No		If yes, is it? <input type="checkbox"/> Indirect Fired <input type="checkbox"/> Direct Fired	
Maximum design heat input and/or maximum horsepower rating: 353 MM Btu/hr		Type and Btu/hr rating of burners:	
List the primary fuel type(s) and if applicable, the secondary fuel type(s). For each fuel type listed, provide the maximum hourly and annual fuel usage for each. Natural Gas			
Describe each fuel expected to be used during the term of the permit.			
Fuel Type	Max. Sulfur Content	Max. Ash Content	BTU Value
Natural Gas	None	None	>1,050 Btu/scf
Process Vent Gases	None	None	Not applicable

<i>Emissions Data</i>		
Criteria Pollutants	Potential Emissions	
	PPH	TPY
Carbon Monoxide (CO)		
Nitrogen Oxides (NO _x)		
Lead (Pb)		
Particulate Matter (PM _{2.5})		
Particulate Matter (PM ₁₀)		
Total Particulate Matter (TSP)		
Sulfur Dioxide (SO ₂)		
Volatile Organic Compounds (VOC)		
Hazardous Air Pollutants	Potential Emissions	
	PPH	TPY
Regulated Pollutants other than Criteria and HAP	Potential Emissions	
	PPH	TPY

List the method(s) used to calculate the potential emissions (include dates of any stack tests conducted, versions of software used, source and dates of emission factors, etc.).

Applicable Requirements

List all applicable requirements for this emission unit. For each applicable requirement, include the underlying rule/regulation citation and/or construction permit with the condition number. (Note: Title V permit condition numbers alone are not the underlying applicable requirements). If an emission limit is calculated based on the type of source and design capacity or if a standard is based on a design parameter, this information should also be included.

See Attachment I for applicable requirements, monitoring, recordkeeping, reporting and testing from existing Title V permit.

Permit Shield

For all applicable requirements listed above, provide monitoring/testing/recordkeeping/reporting which shall be used to demonstrate compliance. If the method is based on a permit or rule, include the condition number or citation. (Note: Each requirement listed above must have an associated method of demonstrating compliance. If there is not already a required method in place, then a method must be proposed.)

See Attachment I for applicable requirements, monitoring, recordkeeping, reporting and testing from existing Title V permit.

Are you in compliance with all applicable requirements for this emission unit? Yes No

If no, complete the **Schedule of Compliance Form** as **ATTACHMENT F**.

ATTACHMENT E - Emission Unit Form			
Emission Unit Description: <i>EO Distribution Header</i>			
Emission unit ID number: EOHDR	Emission unit name: EO Distribution System	List any control devices associated with this emission unit: N/A	
Provide a description of the emission unit (type, method of operation, design parameters, etc.):			
Manufacturer:	Model number:	Serial number:	
Construction date:	Installation date:	Modification date(s):	
Design Capacity (examples: furnaces - tons/hr, tanks - gallons):			
Maximum Hourly Throughput:	Maximum Annual Throughput:	Maximum Operating Schedule:	
Fuel Usage Data (fill out all applicable fields)			
Does this emission unit combust fuel? ___ Yes ___ <u>X</u> No		If yes, is it? ___ Indirect Fired ___ Direct Fired	
Maximum design heat input and/or maximum horsepower rating:		Type and Btu/hr rating of burners:	
List the primary fuel type(s) and if applicable, the secondary fuel type(s). For each fuel type listed, provide the maximum hourly and annual fuel usage for each.			
Describe each fuel expected to be used during the term of the permit.			
Fuel Type	Max. Sulfur Content	Max. Ash Content	BTU Value

UCC South Charleston Facility: Energy Systems & Pipelines/Environmental Operations

<i>Emissions Data</i>		
Criteria Pollutants	Potential Emissions	
	PPH	TPY
Carbon Monoxide (CO)		
Nitrogen Oxides (NO _x)		
Lead (Pb)		
Particulate Matter (PM _{2.5})		
Particulate Matter (PM ₁₀)		
Total Particulate Matter (TSP)		
Sulfur Dioxide (SO ₂)		
Volatile Organic Compounds (VOC)		
Hazardous Air Pollutants	Potential Emissions	
	PPH	TPY
Regulated Pollutants other than Criteria and HAP	Potential Emissions	
	PPH	TPY

List the method(s) used to calculate the potential emissions (include dates of any stack tests conducted, versions of software used, source and dates of emission factors, etc.).

Applicable Requirements

List all applicable requirements for this emission unit. For each applicable requirement, include the underlying rule/regulation citation and/or construction permit with the condition number. (Note: Title V permit condition numbers alone are not the underlying applicable requirements). If an emission limit is calculated based on the type of source and design capacity or if a standard is based on a design parameter, this information should also be included.

See Attachment I for applicable requirements, monitoring, recordkeeping, reporting and testing from existing Title V permit.

Permit Shield

For all applicable requirements listed above, provide monitoring/testing/recordkeeping/reporting which shall be used to demonstrate compliance. If the method is based on a permit or rule, include the condition number or citation. (Note: Each requirement listed above must have an associated method of demonstrating compliance. If there is not already a required method in place, then a method must be proposed.)

See Attachment I for applicable requirements, monitoring, recordkeeping, reporting and testing from existing Title V permit.

Are you in compliance with all applicable requirements for this emission unit? Yes No

If no, complete the **Schedule of Compliance Form** as ATTACHMENT F.

ATTACHMENT E - Emission Unit Form			
Emission Unit Description: <i>Auxiliary Air Compressor</i>			
Emission unit ID number: 001	Emission unit name: A-001	List any control devices associated with this emission unit: N/A	
Provide a description of the emission unit (type, method of operation, design parameters, etc.): Temporary, portable diesel auxiliary air compressor.			
Manufacturer:	Model number:	Serial number:	
Construction date:	Installation date:	Modification date(s):	
Design Capacity (examples: furnaces - tons/hr, tanks - gallons):			
Maximum Hourly Throughput:	Maximum Annual Throughput:	Maximum Operating Schedule:	
Fuel Usage Data (fill out all applicable fields)			
Does this emission unit combust fuel? <input checked="" type="checkbox"/> Yes <input type="checkbox"/> No		If yes, is it? <input type="checkbox"/> Indirect Fired <input type="checkbox"/> Direct Fired	
Maximum design heat input and/or maximum horsepower rating:		Type and Btu/hr rating of burners:	
List the primary fuel type(s) and if applicable, the secondary fuel type(s). For each fuel type listed, provide the maximum hourly and annual fuel usage for each. Diesel Fuel			
Describe each fuel expected to be used during the term of the permit.			
Fuel Type	Max. Sulfur Content	Max. Ash Content	BTU Value
Diesel Fuel			

UCC South Charleston Facility: Energy Systems & Pipelines/Environmental Operations

<i>Emissions Data</i>		
Criteria Pollutants	Potential Emissions	
	PPH	TPY
Carbon Monoxide (CO)		
Nitrogen Oxides (NO _x)		
Lead (Pb)		
Particulate Matter (PM _{2.5})		
Particulate Matter (PM ₁₀)		
Total Particulate Matter (TSP)		
Sulfur Dioxide (SO ₂)		
Volatile Organic Compounds (VOC)		
Hazardous Air Pollutants	Potential Emissions	
	PPH	TPY
Regulated Pollutants other than Criteria and HAP	Potential Emissions	
	PPH	TPY

List the method(s) used to calculate the potential emissions (include dates of any stack tests conducted, versions of software used, source and dates of emission factors, etc.).

Applicable Requirements

List all applicable requirements for this emission unit. For each applicable requirement, include the underlying rule/regulation citation and/or construction permit with the condition number. (Note: Title V permit condition numbers alone are not the underlying applicable requirements). If an emission limit is calculated based on the type of source and design capacity or if a standard is based on a design parameter, this information should also be included.

See Attachment I for applicable requirements, monitoring, recordkeeping, reporting and testing from existing Title V permit.

Permit Shield

For all applicable requirements listed above, provide monitoring/testing/recordkeeping/reporting which shall be used to demonstrate compliance. If the method is based on a permit or rule, include the condition number or citation. (Note: Each requirement listed above must have an associated method of demonstrating compliance. If there is not already a required method in place, then a method must be proposed.)

See Attachment I for applicable requirements, monitoring, recordkeeping, reporting and testing from existing Title V permit.

Are you in compliance with all applicable requirements for this emission unit? Yes No

If no, complete the **Schedule of Compliance Form** as **ATTACHMENT F**.

ATTACHMENT E - Emission Unit Form			
Emission Unit Description: <i>Auxiliary Air Compressor</i>			
Emission unit ID number: 002	Emission unit name: A-002	List any control devices associated with this emission unit: N/A	
Provide a description of the emission unit (type, method of operation, design parameters, etc.): Temporary, portable diesel auxiliary air compressor.			
Manufacturer:	Model number:	Serial number:	
Construction date:	Installation date:	Modification date(s):	
Design Capacity (examples: furnaces - tons/hr, tanks - gallons):			
Maximum Hourly Throughput:	Maximum Annual Throughput:	Maximum Operating Schedule:	
Fuel Usage Data (fill out all applicable fields)			
Does this emission unit combust fuel? <input checked="" type="checkbox"/> Yes <input type="checkbox"/> No		If yes, is it? <input type="checkbox"/> Indirect Fired <input type="checkbox"/> Direct Fired	
Maximum design heat input and/or maximum horsepower rating:		Type and Btu/hr rating of burners:	
List the primary fuel type(s) and if applicable, the secondary fuel type(s). For each fuel type listed, provide the maximum hourly and annual fuel usage for each. Diesel Fuel			
Describe each fuel expected to be used during the term of the permit.			
Fuel Type	Max. Sulfur Content	Max. Ash Content	BTU Value
Diesel Fuel			

UCC South Charleston Facility: Energy Systems & Pipelines/Environmental Operations

<i>Emissions Data</i>		
Criteria Pollutants	Potential Emissions	
	PPH	TPY
Carbon Monoxide (CO)		
Nitrogen Oxides (NO _x)		
Lead (Pb)		
Particulate Matter (PM _{2.5})		
Particulate Matter (PM ₁₀)		
Total Particulate Matter (TSP)		
Sulfur Dioxide (SO ₂)		
Volatile Organic Compounds (VOC)		
Hazardous Air Pollutants	Potential Emissions	
	PPH	TPY
Regulated Pollutants other than Criteria and HAP	Potential Emissions	
	PPH	TPY

List the method(s) used to calculate the potential emissions (include dates of any stack tests conducted, versions of software used, source and dates of emission factors, etc.).

Applicable Requirements

List all applicable requirements for this emission unit. For each applicable requirement, include the underlying rule/regulation citation and/or construction permit with the condition number. (Note: Title V permit condition numbers alone are not the underlying applicable requirements). If an emission limit is calculated based on the type of source and design capacity or if a standard is based on a design parameter, this information should also be included.

See Attachment I for applicable requirements, monitoring, recordkeeping, reporting and testing from existing Title V permit.

Permit Shield

For all applicable requirements listed above, provide monitoring/testing/recordkeeping/reporting which shall be used to demonstrate compliance. If the method is based on a permit or rule, include the condition number or citation. (Note: Each requirement listed above must have an associated method of demonstrating compliance. If there is not already a required method in place, then a method must be proposed.)

See Attachment I for applicable requirements, monitoring, recordkeeping, reporting and testing from existing Title V permit.

Are you in compliance with all applicable requirements for this emission unit? Yes No

If no, complete the **Schedule of Compliance Form** as ATTACHMENT F.

ATTACHMENT E - Emission Unit Form			
Emission Unit Description: <i>Auxiliary Air Compressor</i>			
Emission unit ID number: 003	Emission unit name: A-003	List any control devices associated with this emission unit: N/A	
Provide a description of the emission unit (type, method of operation, design parameters, etc.): Temporary, portable diesel auxiliary air compressor.			
Manufacturer:	Model number:	Serial number:	
Construction date:	Installation date:	Modification date(s):	
Design Capacity (examples: furnaces - tons/hr, tanks - gallons):			
Maximum Hourly Throughput:	Maximum Annual Throughput:	Maximum Operating Schedule:	
Fuel Usage Data (fill out all applicable fields)			
Does this emission unit combust fuel? <input checked="" type="checkbox"/> Yes <input type="checkbox"/> No		If yes, is it? <input type="checkbox"/> Indirect Fired <input type="checkbox"/> Direct Fired	
Maximum design heat input and/or maximum horsepower rating:		Type and Btu/hr rating of burners:	
List the primary fuel type(s) and if applicable, the secondary fuel type(s). For each fuel type listed, provide the maximum hourly and annual fuel usage for each. Diesel Fuel			
Describe each fuel expected to be used during the term of the permit.			
Fuel Type	Max. Sulfur Content	Max. Ash Content	BTU Value
Diesel Fuel			

UCC South Charleston Facility: Energy Systems & Pipelines/Environmental Operations

<i>Emissions Data</i>		
Criteria Pollutants	Potential Emissions	
	PPH	TPY
Carbon Monoxide (CO)		
Nitrogen Oxides (NO _x)		
Lead (Pb)		
Particulate Matter (PM _{2.5})		
Particulate Matter (PM ₁₀)		
Total Particulate Matter (TSP)		
Sulfur Dioxide (SO ₂)		
Volatile Organic Compounds (VOC)		
Hazardous Air Pollutants	Potential Emissions	
	PPH	TPY
Regulated Pollutants other than Criteria and HAP	Potential Emissions	
	PPH	TPY

List the method(s) used to calculate the potential emissions (include dates of any stack tests conducted, versions of software used, source and dates of emission factors, etc.).

Applicable Requirements

List all applicable requirements for this emission unit. For each applicable requirement, include the underlying rule/regulation citation and/or construction permit with the condition number. (Note: Title V permit condition numbers alone are not the underlying applicable requirements). If an emission limit is calculated based on the type of source and design capacity or if a standard is based on a design parameter, this information should also be included.

See Attachment I for applicable requirements, monitoring, recordkeeping, reporting and testing from existing Title V permit.

Permit Shield

For all applicable requirements listed above, provide monitoring/testing/recordkeeping/reporting which shall be used to demonstrate compliance. If the method is based on a permit or rule, include the condition number or citation. (Note: Each requirement listed above must have an associated method of demonstrating compliance. If there is not already a required method in place, then a method must be proposed.)

See Attachment I for applicable requirements, monitoring, recordkeeping, reporting and testing from existing Title V permit.

Are you in compliance with all applicable requirements for this emission unit? Yes No

If no, complete the **Schedule of Compliance Form** as **ATTACHMENT F**.

ATTACHMENT E - Emission Unit Form

Emission Unit Description: *Emergency Pump*

Emission unit ID number: DP03	Emission unit name: Diesel Fueled Firewater Emergency Pump	List any control devices associated with this emission unit: N/A
---	---	--

Provide a description of the emission unit (type, method of operation, design parameters, etc.):

Manufacturer:	Model number:	Serial number:
Construction date: See Attachment D Equipment Table	Installation date: See Attachment D Equipment Table	Modification date(s): See Attachment D Equipment Table

Design Capacity (examples: furnaces - tons/hr, tanks - gallons): See Attachment D Equipment Table

Maximum Hourly Throughput:	Maximum Annual Throughput:	Maximum Operating Schedule:
-----------------------------------	-----------------------------------	------------------------------------

Fuel Usage Data (fill out all applicable fields)

Does this emission unit combust fuel? <input checked="" type="checkbox"/> Yes <input type="checkbox"/> No	If yes, is it? <input type="checkbox"/> Indirect Fired <input type="checkbox"/> Direct Fired
Maximum design heat input and/or maximum horsepower rating: Approx. 380 hp	Type and Btu/hr rating of burners:

List the primary fuel type(s) and if applicable, the secondary fuel type(s). For each fuel type listed, provide the maximum hourly and annual fuel usage for each.

Diesel Fuel

Describe each fuel expected to be used during the term of the permit.

Fuel Type	Max. Sulfur Content	Max. Ash Content	BTU Value

<i>Emissions Data</i>		
Criteria Pollutants	Potential Emissions	
	PPH	TPY
Carbon Monoxide (CO)		
Nitrogen Oxides (NO _x)		
Lead (Pb)		
Particulate Matter (PM _{2.5})		
Particulate Matter (PM ₁₀)		
Total Particulate Matter (TSP)		
Sulfur Dioxide (SO ₂)		
Volatile Organic Compounds (VOC)		
Hazardous Air Pollutants	Potential Emissions	
	PPH	TPY
Regulated Pollutants other than Criteria and HAP	Potential Emissions	
	PPH	TPY

List the method(s) used to calculate the potential emissions (include dates of any stack tests conducted, versions of software used, source and dates of emission factors, etc.).

Applicable Requirements

List all applicable requirements for this emission unit. For each applicable requirement, include the underlying rule/regulation citation and/or construction permit with the condition number. (Note: Title V permit condition numbers alone are not the underlying applicable requirements). If an emission limit is calculated based on the type of source and design capacity or if a standard is based on a design parameter, this information should also be included.

See Attachment I for applicable requirements, monitoring, recordkeeping, reporting and testing from existing Title V permit.

____ Permit Shield

For all applicable requirements listed above, provide monitoring/testing/recordkeeping/reporting which shall be used to demonstrate compliance. If the method is based on a permit or rule, include the condition number or citation. (Note: Each requirement listed above must have an associated method of demonstrating compliance. If there is not already a required method in place, then a method must be proposed.)

See Attachment I for applicable requirements, monitoring, recordkeeping, reporting and testing from existing Title V permit.

Are you in compliance with all applicable requirements for this emission unit? Yes No

If no, complete the **Schedule of Compliance Form** as ATTACHMENT F.

ATTACHMENT E - Emission Unit Form

Emission Unit Description: *Emergency Pump*

Emission unit ID number: DP01	Emission unit name: Diesel Fueled Firewater Emergency Pump	List any control devices associated with this emission unit: N/A
---	---	--

Provide a description of the emission unit (type, method of operation, design parameters, etc.):

Manufacturer:	Model number:	Serial number:
Construction date: See Attachment D Equipment Table	Installation date: See Attachment D Equipment Table	Modification date(s): See Attachment D Equipment Table

Design Capacity (examples: furnaces - tons/hr, tanks - gallons): See Attachment D Equipment Table

Maximum Hourly Throughput:	Maximum Annual Throughput:	Maximum Operating Schedule:
-----------------------------------	-----------------------------------	------------------------------------

Fuel Usage Data (fill out all applicable fields)

Does this emission unit combust fuel? <input checked="" type="checkbox"/> Yes <input type="checkbox"/> No	If yes, is it? <input type="checkbox"/> Indirect Fired <input type="checkbox"/> Direct Fired
Maximum design heat input and/or maximum horsepower rating:	Type and Btu/hr rating of burners:

List the primary fuel type(s) and if applicable, the secondary fuel type(s). For each fuel type listed, provide the maximum hourly and annual fuel usage for each.

Diesel Fuel

Describe each fuel expected to be used during the term of the permit.

Fuel Type	Max. Sulfur Content	Max. Ash Content	BTU Value

<i>Emissions Data</i>		
Criteria Pollutants	Potential Emissions	
	PPH	TPY
Carbon Monoxide (CO)		
Nitrogen Oxides (NO _x)		
Lead (Pb)		
Particulate Matter (PM _{2.5})		
Particulate Matter (PM ₁₀)		
Total Particulate Matter (TSP)		
Sulfur Dioxide (SO ₂)		
Volatile Organic Compounds (VOC)		
Hazardous Air Pollutants	Potential Emissions	
	PPH	TPY
Regulated Pollutants other than Criteria and HAP	Potential Emissions	
	PPH	TPY

List the method(s) used to calculate the potential emissions (include dates of any stack tests conducted, versions of software used, source and dates of emission factors, etc.).

Applicable Requirements

List all applicable requirements for this emission unit. For each applicable requirement, include the underlying rule/regulation citation and/or construction permit with the condition number. (Note: Title V permit condition numbers alone are not the underlying applicable requirements). If an emission limit is calculated based on the type of source and design capacity or if a standard is based on a design parameter, this information should also be included.

See Attachment I for applicable requirements, monitoring, recordkeeping, reporting and testing from existing Title V permit.

Permit Shield

For all applicable requirements listed above, provide monitoring/testing/recordkeeping/reporting which shall be used to demonstrate compliance. If the method is based on a permit or rule, include the condition number or citation. (Note: Each requirement listed above must have an associated method of demonstrating compliance. If there is not already a required method in place, then a method must be proposed.)

See Attachment I for applicable requirements, monitoring, recordkeeping, reporting and testing from existing Title V permit.

Are you in compliance with all applicable requirements for this emission unit? Yes No

If no, complete the **Schedule of Compliance Form** as **ATTACHMENT F**.

ATTACHMENT E - Emission Unit Form

Emission Unit Description: *Emergency Pump*

Emission unit ID number: DP02	Emission unit name: Diesel Fueled Firewater Emergency Pump	List any control devices associated with this emission unit: N/A
---	---	--

Provide a description of the emission unit (type, method of operation, design parameters, etc.):

Manufacturer:	Model number:	Serial number:
Construction date: See Attachment D Equipment Table	Installation date: See Attachment D Equipment Table	Modification date(s): See Attachment D Equipment Table

Design Capacity (examples: furnaces - tons/hr, tanks - gallons): See Attachment D Equipment Table

Maximum Hourly Throughput:	Maximum Annual Throughput:	Maximum Operating Schedule:
-----------------------------------	-----------------------------------	------------------------------------

Fuel Usage Data (fill out all applicable fields)

Does this emission unit combust fuel? <input checked="" type="checkbox"/> Yes <input type="checkbox"/> No	If yes, is it? <input type="checkbox"/> Indirect Fired <input type="checkbox"/> Direct Fired
Maximum design heat input and/or maximum horsepower rating	Type and Btu/hr rating of burners:

List the primary fuel type(s) and if applicable, the secondary fuel type(s). For each fuel type listed, provide the maximum hourly and annual fuel usage for each.

Diesel Fuel

Describe each fuel expected to be used during the term of the permit.

Fuel Type	Max. Sulfur Content	Max. Ash Content	BTU Value

<i>Emissions Data</i>		
Criteria Pollutants	Potential Emissions	
	PPH	TPY
Carbon Monoxide (CO)		
Nitrogen Oxides (NO _x)		
Lead (Pb)		
Particulate Matter (PM _{2.5})		
Particulate Matter (PM ₁₀)		
Total Particulate Matter (TSP)		
Sulfur Dioxide (SO ₂)		
Volatile Organic Compounds (VOC)		
Hazardous Air Pollutants	Potential Emissions	
	PPH	TPY
Regulated Pollutants other than Criteria and HAP	Potential Emissions	
	PPH	TPY

List the method(s) used to calculate the potential emissions (include dates of any stack tests conducted, versions of software used, source and dates of emission factors, etc.).

Applicable Requirements

List all applicable requirements for this emission unit. For each applicable requirement, include the underlying rule/regulation citation and/or construction permit with the condition number. (Note: Title V permit condition numbers alone are not the underlying applicable requirements). If an emission limit is calculated based on the type of source and design capacity or if a standard is based on a design parameter, this information should also be included.

See Attachment I for applicable requirements, monitoring, recordkeeping, reporting and testing from existing Title V permit..

____ Permit Shield

For all applicable requirements listed above, provide monitoring/testing/recordkeeping/reporting which shall be used to demonstrate compliance. If the method is based on a permit or rule, include the condition number or citation. (Note: Each requirement listed above must have an associated method of demonstrating compliance. If there is not already a required method in place, then a method must be proposed.)

See Attachment I for applicable requirements, monitoring, recordkeeping, reporting and testing from existing Title V permit..

Are you in compliance with all applicable requirements for this emission unit? Yes No

If no, complete the **Schedule of Compliance Form** as **ATTACHMENT F**.

ATTACHMENT E - Emission Unit Form

Emission Unit Description: *Maintenance – Paint Booth*

Emission unit ID number: B-307 Paint Booth	Emission unit name: B-307 Paint Booth	List any control devices associated with this emission unit: N/A
--	---	--

Provide a description of the emission unit (type, method of operation, design parameters, etc.):
Paint booth for small parts

Manufacturer:	Model number:	Serial number:
----------------------	----------------------	-----------------------

Construction date: See Attachment D Equipment Table	Installation date: See Attachment D Equipment Table	Modification date(s): See Attachment D Equipment Table
---	---	--

Design Capacity (examples: furnaces - tons/hr, tanks - gallons): See Attachment D Equipment Table

Maximum Hourly Throughput:	Maximum Annual Throughput:	Maximum Operating Schedule: 24 hrs/day, 365 days/yr
-----------------------------------	-----------------------------------	---

Fuel Usage Data (fill out all applicable fields)

Does this emission unit combust fuel? ___Yes ___X_ No	If yes, is it? ___ Indirect Fired ___ Direct Fired
--	--

Maximum design heat input and/or maximum horsepower rating:	Type and Btu/hr rating of burners:
--	---

List the primary fuel type(s) and if applicable, the secondary fuel type(s). For each fuel type listed, provide the maximum hourly and annual fuel usage for each.

Describe each fuel expected to be used during the term of the permit.

Fuel Type	Max. Sulfur Content	Max. Ash Content	BTU Value

<i>Emissions Data</i>		
Criteria Pollutants	Potential Emissions	
	PPH	TPY
Carbon Monoxide (CO)		
Nitrogen Oxides (NO _x)		
Lead (Pb)		
Particulate Matter (PM _{2.5})		
Particulate Matter (PM ₁₀)		
Total Particulate Matter (TSP)		
Sulfur Dioxide (SO ₂)		
Volatile Organic Compounds (VOC)		
Hazardous Air Pollutants	Potential Emissions	
	PPH	TPY
Regulated Pollutants other than Criteria and HAP	Potential Emissions	
	PPH	TPY

List the method(s) used to calculate the potential emissions (include dates of any stack tests conducted, versions of software used, source and dates of emission factors, etc.).

Applicable Requirements

List all applicable requirements for this emission unit. For each applicable requirement, include the underlying rule/regulation citation and/or construction permit with the condition number. (Note: Title V permit condition numbers alone are not the underlying applicable requirements). If an emission limit is calculated based on the type of source and design capacity or if a standard is based on a design parameter, this information should also be included.

From current Title V permit:

____ Permit Shield

For all applicable requirements listed above, provide monitoring/testing/recordkeeping/reporting which shall be used to demonstrate compliance. If the method is based on a permit or rule, include the condition number or citation. (Note: Each requirement listed above must have an associated method of demonstrating compliance. If there is not already a required method in place, then a method must be proposed.)

From current Title V permit:

Are you in compliance with all applicable requirements for this emission unit? Yes No

If no, complete the **Schedule of Compliance Form** as ATTACHMENT F.

ATTACHMENT E - Emission Unit Form

Emission Unit Description: *Maintenance Shop*

Emission unit ID number: B-307 Weld Shop	Emission unit name: B-307 Weld Shop	List any control devices associated with this emission unit: N/A
--	---	--

Provide a description of the emission unit (type, method of operation, design parameters, etc.):

Welding activities

Manufacturer:	Model number:	Serial number:
Construction date: See Attachment D Equipment Table	Installation date: See Attachment D Equipment Table	Modification date(s): See Attachment D Equipment Table

Design Capacity (examples: furnaces - tons/hr, tanks - gallons): See Attachment D Equipment Table

Maximum Hourly Throughput:	Maximum Annual Throughput:	Maximum Operating Schedule: 24 hrs/day, 365 days/yr
-----------------------------------	-----------------------------------	---

Fuel Usage Data (fill out all applicable fields)

Does this emission unit combust fuel? ___Yes ___X___ No	If yes, is it? ___ Indirect Fired ___ Direct Fired
--	--

Maximum design heat input and/or maximum horsepower rating:	Type and Btu/hr rating of burners:
--	---

List the primary fuel type(s) and if applicable, the secondary fuel type(s). For each fuel type listed, provide the maximum hourly and annual fuel usage for each.

Describe each fuel expected to be used during the term of the permit.

Fuel Type	Max. Sulfur Content	Max. Ash Content	BTU Value

<i>Emissions Data</i>		
Criteria Pollutants	Potential Emissions	
	PPH	TPY
Carbon Monoxide (CO)		
Nitrogen Oxides (NO _x)		
Lead (Pb)		
Particulate Matter (PM _{2.5})		
Particulate Matter (PM ₁₀)		
Total Particulate Matter (TSP)		
Sulfur Dioxide (SO ₂)		
Volatile Organic Compounds (VOC)		
Hazardous Air Pollutants	Potential Emissions	
	PPH	TPY
Regulated Pollutants other than Criteria and HAP	Potential Emissions	
	PPH	TPY

List the method(s) used to calculate the potential emissions (include dates of any stack tests conducted, versions of software used, source and dates of emission factors, etc.).

Applicable Requirements

List all applicable requirements for this emission unit. For each applicable requirement, include the underlying rule/regulation citation and/or construction permit with the condition number. (Note: Title V permit condition numbers alone are not the underlying applicable requirements). If an emission limit is calculated based on the type of source and design capacity or if a standard is based on a design parameter, this information should also be included.

From current Title V permit:

____ Permit Shield

For all applicable requirements listed above, provide monitoring/testing/recordkeeping/reporting which shall be used to demonstrate compliance. If the method is based on a permit or rule, include the condition number or citation. (Note: Each requirement listed above must have an associated method of demonstrating compliance. If there is not already a required method in place, then a method must be proposed.)

From current Title V permit:

Are you in compliance with all applicable requirements for this emission unit? Yes No

If no, complete the **Schedule of Compliance Form** as ATTACHMENT F.

ATTACHMENT E - Emission Unit Form

Emission Unit Description: *Storage Tank*

Emission unit ID number: T9000	Emission unit name: Tank 9000	List any control devices associated with this emission unit: N/A
--	---	--

Provide a description of the emission unit (type, method of operation, design parameters, etc.):
Storage tank

Manufacturer:	Model number:	Serial number:
----------------------	----------------------	-----------------------

Construction date: See Attachment D Equipment Table	Installation date: See Attachment D Equipment Table	Modification date(s): See Attachment D Equipment Table
---	---	--

Design Capacity (examples: furnaces - tons/hr, tanks - gallons): See Attachment D Equipment Table

Maximum Hourly Throughput:	Maximum Annual Throughput:	Maximum Operating Schedule: 24 hrs/day, 365 days/yr
-----------------------------------	-----------------------------------	---

Fuel Usage Data (fill out all applicable fields)

Does this emission unit combust fuel? ___Yes ___X_ No	If yes, is it? ___ Indirect Fired ___Direct Fired
--	---

Maximum design heat input and/or maximum horsepower rating:	Type and Btu/hr rating of burners:
--	---

List the primary fuel type(s) and if applicable, the secondary fuel type(s). For each fuel type listed, provide the maximum hourly and annual fuel usage for each.

Describe each fuel expected to be used during the term of the permit.

Fuel Type	Max. Sulfur Content	Max. Ash Content	BTU Value

<i>Emissions Data</i>		
Criteria Pollutants	Potential Emissions	
	PPH	TPY
Carbon Monoxide (CO)		
Nitrogen Oxides (NO _x)		
Lead (Pb)		
Particulate Matter (PM _{2.5})		
Particulate Matter (PM ₁₀)		
Total Particulate Matter (TSP)		
Sulfur Dioxide (SO ₂)		
Volatile Organic Compounds (VOC)		
Hazardous Air Pollutants	Potential Emissions	
	PPH	TPY
Regulated Pollutants other than Criteria and HAP	Potential Emissions	
	PPH	TPY

List the method(s) used to calculate the potential emissions (include dates of any stack tests conducted, versions of software used, source and dates of emission factors, etc.).

Applicable Requirements

List all applicable requirements for this emission unit. For each applicable requirement, include the underlying rule/regulation citation and/or construction permit with the condition number. (Note: Title V permit condition numbers alone are not the underlying applicable requirements). If an emission limit is calculated based on the type of source and design capacity or if a standard is based on a design parameter, this information should also be included.

From current Title V permit:

____ Permit Shield

For all applicable requirements listed above, provide monitoring/testing/recordkeeping/reporting which shall be used to demonstrate compliance. If the method is based on a permit or rule, include the condition number or citation. (Note: Each requirement listed above must have an associated method of demonstrating compliance. If there is not already a required method in place, then a method must be proposed.)

From current Title V permit:

Are you in compliance with all applicable requirements for this emission unit? Yes No

If no, complete the **Schedule of Compliance Form** as ATTACHMENT F.

ATTACHMENT E - Emission Unit Form

Emission Unit Description: *Storage Tank*

Emission unit ID number: 9781	Emission unit name: Tank 9781	List any control devices associated with this emission unit: N/A
---	---	--

Provide a description of the emission unit (type, method of operation, design parameters, etc.):
Storage tank.

Manufacturer:	Model number:	Serial number:
----------------------	----------------------	-----------------------

Construction date: See Attachment D Equipment Table	Installation date: See Attachment D Equipment Table	Modification date(s): See Attachment D Equipment Table
---	---	--

Design Capacity (examples: furnaces - tons/hr, tanks - gallons): See Attachment D Equipment Table

Maximum Hourly Throughput:	Maximum Annual Throughput:	Maximum Operating Schedule: 24 hrs/day, 365 days/yr
-----------------------------------	-----------------------------------	---

Fuel Usage Data (fill out all applicable fields)

Does this emission unit combust fuel? ___Yes ___X___ No	If yes, is it? ___ Indirect Fired ___ Direct Fired
--	--

Maximum design heat input and/or maximum horsepower rating:	Type and Btu/hr rating of burners:
--	---

List the primary fuel type(s) and if applicable, the secondary fuel type(s). For each fuel type listed, provide the maximum hourly and annual fuel usage for each.

Describe each fuel expected to be used during the term of the permit.

Fuel Type	Max. Sulfur Content	Max. Ash Content	BTU Value

<i>Emissions Data</i>		
Criteria Pollutants	Potential Emissions	
	PPH	TPY
Carbon Monoxide (CO)		
Nitrogen Oxides (NO _x)		
Lead (Pb)		
Particulate Matter (PM _{2.5})		
Particulate Matter (PM ₁₀)		
Total Particulate Matter (TSP)		
Sulfur Dioxide (SO ₂)		
Volatile Organic Compounds (VOC)		
Hazardous Air Pollutants	Potential Emissions	
	PPH	TPY
Regulated Pollutants other than Criteria and HAP	Potential Emissions	
	PPH	TPY

List the method(s) used to calculate the potential emissions (include dates of any stack tests conducted, versions of software used, source and dates of emission factors, etc.).

Applicable Requirements

List all applicable requirements for this emission unit. For each applicable requirement, include the underlying rule/regulation citation and/or construction permit with the condition number. (Note: Title V permit condition numbers alone are not the underlying applicable requirements). If an emission limit is calculated based on the type of source and design capacity or if a standard is based on a design parameter, this information should also be included.

From current Title V permit:

____ Permit Shield

For all applicable requirements listed above, provide monitoring/testing/recordkeeping/reporting which shall be used to demonstrate compliance. If the method is based on a permit or rule, include the condition number or citation. (Note: Each requirement listed above must have an associated method of demonstrating compliance. If there is not already a required method in place, then a method must be proposed.)

From current Title V permit:

Are you in compliance with all applicable requirements for this emission unit? Yes No

If no, complete the **Schedule of Compliance Form** as ATTACHMENT F.

ATTACHMENT E - Emission Unit Form

Emission Unit Description: *Storage Tank*

Emission unit ID number: 9782	Emission unit name: Tank 9782	List any control devices associated with this emission unit: N/A
---	---	--

Provide a description of the emission unit (type, method of operation, design parameters, etc.):
Storage tank.

Manufacturer:	Model number:	Serial number:
----------------------	----------------------	-----------------------

Construction date: See Attachment D Equipment Table	Installation date: See Attachment D Equipment Table	Modification date(s): See Attachment D Equipment Table
---	---	--

Design Capacity (examples: furnaces - tons/hr, tanks - gallons): See Attachment D Equipment Table

Maximum Hourly Throughput:	Maximum Annual Throughput:	Maximum Operating Schedule: 24 hrs/day, 365 days/yr
-----------------------------------	-----------------------------------	---

Fuel Usage Data (fill out all applicable fields)

Does this emission unit combust fuel? ___Yes ___X___ No	If yes, is it? ___ Indirect Fired ___ Direct Fired
--	--

Maximum design heat input and/or maximum horsepower rating:	Type and Btu/hr rating of burners:
--	---

List the primary fuel type(s) and if applicable, the secondary fuel type(s). For each fuel type listed, provide the maximum hourly and annual fuel usage for each.

Describe each fuel expected to be used during the term of the permit.

Fuel Type	Max. Sulfur Content	Max. Ash Content	BTU Value

<i>Emissions Data</i>		
Criteria Pollutants	Potential Emissions	
	PPH	TPY
Carbon Monoxide (CO)		
Nitrogen Oxides (NO _x)		
Lead (Pb)		
Particulate Matter (PM _{2.5})		
Particulate Matter (PM ₁₀)		
Total Particulate Matter (TSP)		
Sulfur Dioxide (SO ₂)		
Volatile Organic Compounds (VOC)		
Hazardous Air Pollutants	Potential Emissions	
	PPH	TPY
Regulated Pollutants other than Criteria and HAP	Potential Emissions	
	PPH	TPY

List the method(s) used to calculate the potential emissions (include dates of any stack tests conducted, versions of software used, source and dates of emission factors, etc.).

Applicable Requirements

List all applicable requirements for this emission unit. For each applicable requirement, include the underlying rule/regulation citation and/or construction permit with the condition number. (Note: Title V permit condition numbers alone are not the underlying applicable requirements). If an emission limit is calculated based on the type of source and design capacity or if a standard is based on a design parameter, this information should also be included.

From current Title V permit:

____ Permit Shield

For all applicable requirements listed above, provide monitoring/testing/recordkeeping/reporting which shall be used to demonstrate compliance. If the method is based on a permit or rule, include the condition number or citation. (Note: Each requirement listed above must have an associated method of demonstrating compliance. If there is not already a required method in place, then a method must be proposed.)

From current Title V permit:

Are you in compliance with all applicable requirements for this emission unit? Yes No

If no, complete the **Schedule of Compliance Form** as ATTACHMENT F.

ATTACHMENT E - Emission Unit Form

Emission Unit Description: *Storage Tank*

Emission unit ID number: 9783	Emission unit name: Tank 9783	List any control devices associated with this emission unit: N/A
---	---	--

Provide a description of the emission unit (type, method of operation, design parameters, etc.):
Storage tank.

Manufacturer:	Model number:	Serial number:
----------------------	----------------------	-----------------------

Construction date: See Attachment D Equipment Table	Installation date: See Attachment D Equipment Table	Modification date(s): See Attachment D Equipment Table
---	---	--

Design Capacity (examples: furnaces - tons/hr, tanks - gallons): See Attachment D Equipment Table

Maximum Hourly Throughput:	Maximum Annual Throughput:	Maximum Operating Schedule: 24 hrs/day, 365 days/yr
-----------------------------------	-----------------------------------	---

Fuel Usage Data (fill out all applicable fields)

Does this emission unit combust fuel? <input type="checkbox"/> Yes <input checked="" type="checkbox"/> No	If yes, is it? <input type="checkbox"/> Indirect Fired <input type="checkbox"/> Direct Fired
--	--

Maximum design heat input and/or maximum horsepower rating:	Type and Btu/hr rating of burners:
--	---

List the primary fuel type(s) and if applicable, the secondary fuel type(s). For each fuel type listed, provide the maximum hourly and annual fuel usage for each.

Describe each fuel expected to be used during the term of the permit.

Fuel Type	Max. Sulfur Content	Max. Ash Content	BTU Value

<i>Emissions Data</i>		
Criteria Pollutants	Potential Emissions	
	PPH	TPY
Carbon Monoxide (CO)		
Nitrogen Oxides (NO _x)		
Lead (Pb)		
Particulate Matter (PM _{2.5})		
Particulate Matter (PM ₁₀)		
Total Particulate Matter (TSP)		
Sulfur Dioxide (SO ₂)		
Volatile Organic Compounds (VOC)		
Hazardous Air Pollutants	Potential Emissions	
	PPH	TPY
Regulated Pollutants other than Criteria and HAP	Potential Emissions	
	PPH	TPY

List the method(s) used to calculate the potential emissions (include dates of any stack tests conducted, versions of software used, source and dates of emission factors, etc.).

Applicable Requirements

List all applicable requirements for this emission unit. For each applicable requirement, include the underlying rule/regulation citation and/or construction permit with the condition number. (Note: Title V permit condition numbers alone are not the underlying applicable requirements). If an emission limit is calculated based on the type of source and design capacity or if a standard is based on a design parameter, this information should also be included.

From current Title V permit:

____ Permit Shield

For all applicable requirements listed above, provide monitoring/testing/recordkeeping/reporting which shall be used to demonstrate compliance. If the method is based on a permit or rule, include the condition number or citation. (Note: Each requirement listed above must have an associated method of demonstrating compliance. If there is not already a required method in place, then a method must be proposed.)

From current Title V permit:

Are you in compliance with all applicable requirements for this emission unit? Yes No

If no, complete the **Schedule of Compliance Form** as ATTACHMENT F.

ATTACHMENT E - Emission Unit Form

Emission Unit Description: <i>Storage Tank</i>			
Emission unit ID number: 9784	Emission unit name: Tank 9784	List any control devices associated with this emission unit: N/A	
Provide a description of the emission unit (type, method of operation, design parameters, etc.): Storage tank.			
Manufacturer:	Model number:	Serial number:	
Construction date: See Attachment D Equipment Table	Installation date: See Attachment D Equipment Table	Modification date(s): See Attachment D Equipment Table	
Design Capacity (examples: furnaces - tons/hr, tanks - gallons): See Attachment D Equipment Table			
Maximum Hourly Throughput:	Maximum Annual Throughput:	Maximum Operating Schedule: 24 hrs/day, 365 days/yr	
Fuel Usage Data (fill out all applicable fields)			
Does this emission unit combust fuel? ___Yes ___X___ No		If yes, is it? ___ Indirect Fired ___ Direct Fired	
Maximum design heat input and/or maximum horsepower rating:		Type and Btu/hr rating of burners:	
List the primary fuel type(s) and if applicable, the secondary fuel type(s). For each fuel type listed, provide the maximum hourly and annual fuel usage for each.			
Describe each fuel expected to be used during the term of the permit.			
Fuel Type	Max. Sulfur Content	Max. Ash Content	BTU Value

<i>Emissions Data</i>		
Criteria Pollutants	Potential Emissions	
	PPH	TPY
Carbon Monoxide (CO)		
Nitrogen Oxides (NO _x)		
Lead (Pb)		
Particulate Matter (PM _{2.5})		
Particulate Matter (PM ₁₀)		
Total Particulate Matter (TSP)		
Sulfur Dioxide (SO ₂)		
Volatile Organic Compounds (VOC)		
Hazardous Air Pollutants	Potential Emissions	
	PPH	TPY
Regulated Pollutants other than Criteria and HAP	Potential Emissions	
	PPH	TPY

List the method(s) used to calculate the potential emissions (include dates of any stack tests conducted, versions of software used, source and dates of emission factors, etc.).

Applicable Requirements

List all applicable requirements for this emission unit. For each applicable requirement, include the underlying rule/regulation citation and/or construction permit with the condition number. (Note: Title V permit condition numbers alone are not the underlying applicable requirements). If an emission limit is calculated based on the type of source and design capacity or if a standard is based on a design parameter, this information should also be included.

From current Title V permit:

____ Permit Shield

For all applicable requirements listed above, provide monitoring/testing/recordkeeping/reporting which shall be used to demonstrate compliance. If the method is based on a permit or rule, include the condition number or citation. (Note: Each requirement listed above must have an associated method of demonstrating compliance. If there is not already a required method in place, then a method must be proposed.)

From current Title V permit:

Are you in compliance with all applicable requirements for this emission unit? Yes No

If no, complete the **Schedule of Compliance Form** as ATTACHMENT F.

ATTACHMENT E - Emission Unit Form

Emission Unit Description: *Storage Tank*

Emission unit ID number: 9785	Emission unit name: Tank 9785	List any control devices associated with this emission unit: N/A
---	---	--

Provide a description of the emission unit (type, method of operation, design parameters, etc.):
Storage tank.

Manufacturer:	Model number:	Serial number:
----------------------	----------------------	-----------------------

Construction date: See Attachment D Equipment Table	Installation date: See Attachment D Equipment Table	Modification date(s): See Attachment D Equipment Table
---	---	--

Design Capacity (examples: furnaces - tons/hr, tanks - gallons): See Attachment D Equipment Table

Maximum Hourly Throughput:	Maximum Annual Throughput:	Maximum Operating Schedule: 24 hrs/day, 365 days/yr
-----------------------------------	-----------------------------------	---

Fuel Usage Data (fill out all applicable fields)

Does this emission unit combust fuel? <input type="checkbox"/> Yes <input checked="" type="checkbox"/> No	If yes, is it? <input type="checkbox"/> Indirect Fired <input type="checkbox"/> Direct Fired
--	--

Maximum design heat input and/or maximum horsepower rating:	Type and Btu/hr rating of burners:
--	---

List the primary fuel type(s) and if applicable, the secondary fuel type(s). For each fuel type listed, provide the maximum hourly and annual fuel usage for each.

Describe each fuel expected to be used during the term of the permit.

Fuel Type	Max. Sulfur Content	Max. Ash Content	BTU Value

<i>Emissions Data</i>		
Criteria Pollutants	Potential Emissions	
	PPH	TPY
Carbon Monoxide (CO)		
Nitrogen Oxides (NO _x)		
Lead (Pb)		
Particulate Matter (PM _{2.5})		
Particulate Matter (PM ₁₀)		
Total Particulate Matter (TSP)		
Sulfur Dioxide (SO ₂)		
Volatile Organic Compounds (VOC)		
Hazardous Air Pollutants	Potential Emissions	
	PPH	TPY
Regulated Pollutants other than Criteria and HAP	Potential Emissions	
	PPH	TPY

List the method(s) used to calculate the potential emissions (include dates of any stack tests conducted, versions of software used, source and dates of emission factors, etc.).

Applicable Requirements

List all applicable requirements for this emission unit. For each applicable requirement, include the underlying rule/regulation citation and/or construction permit with the condition number. (Note: Title V permit condition numbers alone are not the underlying applicable requirements). If an emission limit is calculated based on the type of source and design capacity or if a standard is based on a design parameter, this information should also be included.

From current Title V permit:

____ Permit Shield

For all applicable requirements listed above, provide monitoring/testing/recordkeeping/reporting which shall be used to demonstrate compliance. If the method is based on a permit or rule, include the condition number or citation. (Note: Each requirement listed above must have an associated method of demonstrating compliance. If there is not already a required method in place, then a method must be proposed.)

From current Title V permit:

Are you in compliance with all applicable requirements for this emission unit? Yes No

If no, complete the **Schedule of Compliance Form** as ATTACHMENT F.

ATTACHMENT E - Emission Unit Form

Emission Unit Description: *Storage Tank*

Emission unit ID number: 9786	Emission unit name: Tank 9786	List any control devices associated with this emission unit: N/A
---	---	--

Provide a description of the emission unit (type, method of operation, design parameters, etc.):
Storage tank.

Manufacturer:	Model number:	Serial number:
----------------------	----------------------	-----------------------

Construction date: See Attachment D Equipment Table	Installation date: See Attachment D Equipment Table	Modification date(s): See Attachment D Equipment Table
---	---	--

Design Capacity (examples: furnaces - tons/hr, tanks - gallons): See Attachment D Equipment Table

Maximum Hourly Throughput:	Maximum Annual Throughput:	Maximum Operating Schedule: 24 hrs/day, 365 days/yr
-----------------------------------	-----------------------------------	---

Fuel Usage Data (fill out all applicable fields)

Does this emission unit combust fuel? <input type="checkbox"/> Yes <input checked="" type="checkbox"/> No	If yes, is it? <input type="checkbox"/> Indirect Fired <input type="checkbox"/> Direct Fired
--	--

Maximum design heat input and/or maximum horsepower rating:	Type and Btu/hr rating of burners:
--	---

List the primary fuel type(s) and if applicable, the secondary fuel type(s). For each fuel type listed, provide the maximum hourly and annual fuel usage for each.

Describe each fuel expected to be used during the term of the permit.

Fuel Type	Max. Sulfur Content	Max. Ash Content	BTU Value

<i>Emissions Data</i>		
Criteria Pollutants	Potential Emissions	
	PPH	TPY
Carbon Monoxide (CO)		
Nitrogen Oxides (NO _x)		
Lead (Pb)		
Particulate Matter (PM _{2.5})		
Particulate Matter (PM ₁₀)		
Total Particulate Matter (TSP)		
Sulfur Dioxide (SO ₂)		
Volatile Organic Compounds (VOC)		
Hazardous Air Pollutants	Potential Emissions	
	PPH	TPY
Regulated Pollutants other than Criteria and HAP	Potential Emissions	
	PPH	TPY

List the method(s) used to calculate the potential emissions (include dates of any stack tests conducted, versions of software used, source and dates of emission factors, etc.).

Applicable Requirements

List all applicable requirements for this emission unit. For each applicable requirement, include the underlying rule/regulation citation and/or construction permit with the condition number. (Note: Title V permit condition numbers alone are not the underlying applicable requirements). If an emission limit is calculated based on the type of source and design capacity or if a standard is based on a design parameter, this information should also be included.

From current Title V permit:

____ Permit Shield

For all applicable requirements listed above, provide monitoring/testing/recordkeeping/reporting which shall be used to demonstrate compliance. If the method is based on a permit or rule, include the condition number or citation. (Note: Each requirement listed above must have an associated method of demonstrating compliance. If there is not already a required method in place, then a method must be proposed.)

From current Title V permit:

Are you in compliance with all applicable requirements for this emission unit? Yes No

If no, complete the **Schedule of Compliance Form** as ATTACHMENT F.

ATTACHMENT E - Emission Unit Form

Emission Unit Description: *Storage Tank*

Emission unit ID number: 9793	Emission unit name: Tank 9793	List any control devices associated with this emission unit: N/A
---	---	--

Provide a description of the emission unit (type, method of operation, design parameters, etc.):
Storage tank.

Manufacturer:	Model number:	Serial number:
----------------------	----------------------	-----------------------

Construction date: See Attachment D Equipment Table	Installation date: See Attachment D Equipment Table	Modification date(s): See Attachment D Equipment Table
---	---	--

Design Capacity (examples: furnaces - tons/hr, tanks - gallons): See Attachment D Equipment Table

Maximum Hourly Throughput:	Maximum Annual Throughput:	Maximum Operating Schedule: 24 hrs/day, 365 days/yr
-----------------------------------	-----------------------------------	---

Fuel Usage Data (fill out all applicable fields)

Does this emission unit combust fuel? <input type="checkbox"/> Yes <input checked="" type="checkbox"/> No	If yes, is it? <input type="checkbox"/> Indirect Fired <input type="checkbox"/> Direct Fired
--	--

Maximum design heat input and/or maximum horsepower rating:	Type and Btu/hr rating of burners:
--	---

List the primary fuel type(s) and if applicable, the secondary fuel type(s). For each fuel type listed, provide the maximum hourly and annual fuel usage for each.

Describe each fuel expected to be used during the term of the permit.

Fuel Type	Max. Sulfur Content	Max. Ash Content	BTU Value

<i>Emissions Data</i>		
Criteria Pollutants	Potential Emissions	
	PPH	TPY
Carbon Monoxide (CO)		
Nitrogen Oxides (NO _x)		
Lead (Pb)		
Particulate Matter (PM _{2.5})		
Particulate Matter (PM ₁₀)		
Total Particulate Matter (TSP)		
Sulfur Dioxide (SO ₂)		
Volatile Organic Compounds (VOC)		
Hazardous Air Pollutants	Potential Emissions	
	PPH	TPY
Regulated Pollutants other than Criteria and HAP	Potential Emissions	
	PPH	TPY

List the method(s) used to calculate the potential emissions (include dates of any stack tests conducted, versions of software used, source and dates of emission factors, etc.).

Applicable Requirements

List all applicable requirements for this emission unit. For each applicable requirement, include the underlying rule/regulation citation and/or construction permit with the condition number. (Note: Title V permit condition numbers alone are not the underlying applicable requirements). If an emission limit is calculated based on the type of source and design capacity or if a standard is based on a design parameter, this information should also be included.

From current Title V permit:

____ Permit Shield

For all applicable requirements listed above, provide monitoring/testing/recordkeeping/reporting which shall be used to demonstrate compliance. If the method is based on a permit or rule, include the condition number or citation. (Note: Each requirement listed above must have an associated method of demonstrating compliance. If there is not already a required method in place, then a method must be proposed.)

From current Title V permit:

Are you in compliance with all applicable requirements for this emission unit? Yes No

If no, complete the **Schedule of Compliance Form** as ATTACHMENT F.

ATTACHMENT E - Emission Unit Form

Emission Unit Description: *Storage Tank*

Emission unit ID number: 9798	Emission unit name: Tank 9798	List any control devices associated with this emission unit: N/A
---	---	--

Provide a description of the emission unit (type, method of operation, design parameters, etc.):
Storage tank.

Manufacturer:	Model number:	Serial number:
----------------------	----------------------	-----------------------

Construction date: See Attachment D Equipment Table	Installation date: See Attachment D Equipment Table	Modification date(s): See Attachment D Equipment Table
---	---	--

Design Capacity (examples: furnaces - tons/hr, tanks - gallons): See Attachment D Equipment Table

Maximum Hourly Throughput:	Maximum Annual Throughput:	Maximum Operating Schedule: 24 hrs/day, 365 days/yr
-----------------------------------	-----------------------------------	---

Fuel Usage Data (fill out all applicable fields)

Does this emission unit combust fuel? <input type="checkbox"/> Yes <input checked="" type="checkbox"/> No	If yes, is it? <input type="checkbox"/> Indirect Fired <input type="checkbox"/> Direct Fired
--	--

Maximum design heat input and/or maximum horsepower rating:	Type and Btu/hr rating of burners:
--	---

List the primary fuel type(s) and if applicable, the secondary fuel type(s). For each fuel type listed, provide the maximum hourly and annual fuel usage for each.

Describe each fuel expected to be used during the term of the permit.

Fuel Type	Max. Sulfur Content	Max. Ash Content	BTU Value

<i>Emissions Data</i>		
Criteria Pollutants	Potential Emissions	
	PPH	TPY
Carbon Monoxide (CO)		
Nitrogen Oxides (NO _x)		
Lead (Pb)		
Particulate Matter (PM _{2.5})		
Particulate Matter (PM ₁₀)		
Total Particulate Matter (TSP)		
Sulfur Dioxide (SO ₂)		
Volatile Organic Compounds (VOC)		
Hazardous Air Pollutants	Potential Emissions	
	PPH	TPY
Regulated Pollutants other than Criteria and HAP	Potential Emissions	
	PPH	TPY

List the method(s) used to calculate the potential emissions (include dates of any stack tests conducted, versions of software used, source and dates of emission factors, etc.).

Applicable Requirements

List all applicable requirements for this emission unit. For each applicable requirement, include the underlying rule/regulation citation and/or construction permit with the condition number. (Note: Title V permit condition numbers alone are not the underlying applicable requirements). If an emission limit is calculated based on the type of source and design capacity or if a standard is based on a design parameter, this information should also be included.

From current Title V permit:

____ Permit Shield

For all applicable requirements listed above, provide monitoring/testing/recordkeeping/reporting which shall be used to demonstrate compliance. If the method is based on a permit or rule, include the condition number or citation. (Note: Each requirement listed above must have an associated method of demonstrating compliance. If there is not already a required method in place, then a method must be proposed.)

From current Title V permit:

Are you in compliance with all applicable requirements for this emission unit? Yes No

If no, complete the **Schedule of Compliance Form** as ATTACHMENT F.

ATTACHMENT E - Emission Unit Form

Emission Unit Description: *Storage Tank*

Emission unit ID number: 9811	Emission unit name: Tank 9811	List any control devices associated with this emission unit: N/A
---	---	--

Provide a description of the emission unit (type, method of operation, design parameters, etc.):
Storage tank.

Manufacturer:	Model number:	Serial number:
----------------------	----------------------	-----------------------

Construction date: See Attachment D Equipment Table	Installation date: See Attachment D Equipment Table	Modification date(s): See Attachment D Equipment Table
---	---	--

Design Capacity (examples: furnaces - tons/hr, tanks - gallons): See Attachment D Equipment Table

Maximum Hourly Throughput:	Maximum Annual Throughput:	Maximum Operating Schedule: 24 hrs/day, 365 days/yr
-----------------------------------	-----------------------------------	---

Fuel Usage Data (fill out all applicable fields)

Does this emission unit combust fuel? <input type="checkbox"/> Yes <input checked="" type="checkbox"/> No	If yes, is it? <input type="checkbox"/> Indirect Fired <input type="checkbox"/> Direct Fired
--	--

Maximum design heat input and/or maximum horsepower rating:	Type and Btu/hr rating of burners:
--	---

List the primary fuel type(s) and if applicable, the secondary fuel type(s). For each fuel type listed, provide the maximum hourly and annual fuel usage for each.

Describe each fuel expected to be used during the term of the permit.

Fuel Type	Max. Sulfur Content	Max. Ash Content	BTU Value

<i>Emissions Data</i>		
Criteria Pollutants	Potential Emissions	
	PPH	TPY
Carbon Monoxide (CO)		
Nitrogen Oxides (NO _x)		
Lead (Pb)		
Particulate Matter (PM _{2.5})		
Particulate Matter (PM ₁₀)		
Total Particulate Matter (TSP)		
Sulfur Dioxide (SO ₂)		
Volatile Organic Compounds (VOC)		
Hazardous Air Pollutants	Potential Emissions	
	PPH	TPY
Regulated Pollutants other than Criteria and HAP	Potential Emissions	
	PPH	TPY

List the method(s) used to calculate the potential emissions (include dates of any stack tests conducted, versions of software used, source and dates of emission factors, etc.).

Applicable Requirements

List all applicable requirements for this emission unit. For each applicable requirement, include the underlying rule/regulation citation and/or construction permit with the condition number. (Note: Title V permit condition numbers alone are not the underlying applicable requirements). If an emission limit is calculated based on the type of source and design capacity or if a standard is based on a design parameter, this information should also be included.

From current Title V permit:

____ Permit Shield

For all applicable requirements listed above, provide monitoring/testing/recordkeeping/reporting which shall be used to demonstrate compliance. If the method is based on a permit or rule, include the condition number or citation. (Note: Each requirement listed above must have an associated method of demonstrating compliance. If there is not already a required method in place, then a method must be proposed.)

From current Title V permit:

Are you in compliance with all applicable requirements for this emission unit? Yes No

If no, complete the **Schedule of Compliance Form** as ATTACHMENT F.

ATTACHMENT E - Emission Unit Form

Emission Unit Description: *Storage Tank*

Emission unit ID number: 9812	Emission unit name: Tank 9812	List any control devices associated with this emission unit: N/A
---	---	--

Provide a description of the emission unit (type, method of operation, design parameters, etc.):
Storage tank.

Manufacturer:	Model number:	Serial number:
----------------------	----------------------	-----------------------

Construction date: See Attachment D Equipment Table	Installation date: See Attachment D Equipment Table	Modification date(s): See Attachment D Equipment Table
---	---	--

Design Capacity (examples: furnaces - tons/hr, tanks - gallons): See Attachment D Equipment Table

Maximum Hourly Throughput:	Maximum Annual Throughput:	Maximum Operating Schedule: 24 hrs/day, 365 days/yr
-----------------------------------	-----------------------------------	---

Fuel Usage Data (fill out all applicable fields)

Does this emission unit combust fuel? ___Yes ___X___ No	If yes, is it? ___ Indirect Fired ___ Direct Fired
--	--

Maximum design heat input and/or maximum horsepower rating:	Type and Btu/hr rating of burners:
--	---

List the primary fuel type(s) and if applicable, the secondary fuel type(s). For each fuel type listed, provide the maximum hourly and annual fuel usage for each.

Describe each fuel expected to be used during the term of the permit.

Fuel Type	Max. Sulfur Content	Max. Ash Content	BTU Value

<i>Emissions Data</i>		
Criteria Pollutants	Potential Emissions	
	PPH	TPY
Carbon Monoxide (CO)		
Nitrogen Oxides (NO _x)		
Lead (Pb)		
Particulate Matter (PM _{2.5})		
Particulate Matter (PM ₁₀)		
Total Particulate Matter (TSP)		
Sulfur Dioxide (SO ₂)		
Volatile Organic Compounds (VOC)		
Hazardous Air Pollutants	Potential Emissions	
	PPH	TPY
Regulated Pollutants other than Criteria and HAP	Potential Emissions	
	PPH	TPY

List the method(s) used to calculate the potential emissions (include dates of any stack tests conducted, versions of software used, source and dates of emission factors, etc.).

Applicable Requirements

List all applicable requirements for this emission unit. For each applicable requirement, include the underlying rule/regulation citation and/or construction permit with the condition number. (Note: Title V permit condition numbers alone are not the underlying applicable requirements). If an emission limit is calculated based on the type of source and design capacity or if a standard is based on a design parameter, this information should also be included.

From current Title V permit:

____ Permit Shield

For all applicable requirements listed above, provide monitoring/testing/recordkeeping/reporting which shall be used to demonstrate compliance. If the method is based on a permit or rule, include the condition number or citation. (Note: Each requirement listed above must have an associated method of demonstrating compliance. If there is not already a required method in place, then a method must be proposed.)

From current Title V permit:

Are you in compliance with all applicable requirements for this emission unit? Yes No

If no, complete the **Schedule of Compliance Form** as ATTACHMENT F.

ATTACHMENT E - Emission Unit Form

Emission Unit Description: *Storage Tank*

Emission unit ID number: 9813	Emission unit name: Tank 9813	List any control devices associated with this emission unit: N/A
---	---	--

Provide a description of the emission unit (type, method of operation, design parameters, etc.):

Storage tank.

Manufacturer:	Model number:	Serial number:
----------------------	----------------------	-----------------------

Construction date: See Attachment D Equipment Table	Installation date: See Attachment D Equipment Table	Modification date(s): See Attachment D Equipment Table
---	---	--

Design Capacity (examples: furnaces - tons/hr, tanks - gallons): See Attachment D Equipment Table

Maximum Hourly Throughput:	Maximum Annual Throughput:	Maximum Operating Schedule: 24 hrs/day, 365 days/yr
-----------------------------------	-----------------------------------	---

Fuel Usage Data (fill out all applicable fields)

Does this emission unit combust fuel? ___Yes ___X___ No	If yes, is it? ___ Indirect Fired ___ Direct Fired
--	--

Maximum design heat input and/or maximum horsepower rating:	Type and Btu/hr rating of burners:
--	---

List the primary fuel type(s) and if applicable, the secondary fuel type(s). For each fuel type listed, provide the maximum hourly and annual fuel usage for each.

Describe each fuel expected to be used during the term of the permit.

Fuel Type	Max. Sulfur Content	Max. Ash Content	BTU Value

<i>Emissions Data</i>		
Criteria Pollutants	Potential Emissions	
	PPH	TPY
Carbon Monoxide (CO)		
Nitrogen Oxides (NO _x)		
Lead (Pb)		
Particulate Matter (PM _{2.5})		
Particulate Matter (PM ₁₀)		
Total Particulate Matter (TSP)		
Sulfur Dioxide (SO ₂)		
Volatile Organic Compounds (VOC)		
Hazardous Air Pollutants	Potential Emissions	
	PPH	TPY
Regulated Pollutants other than Criteria and HAP	Potential Emissions	
	PPH	TPY

List the method(s) used to calculate the potential emissions (include dates of any stack tests conducted, versions of software used, source and dates of emission factors, etc.).

Applicable Requirements

List all applicable requirements for this emission unit. For each applicable requirement, include the underlying rule/regulation citation and/or construction permit with the condition number. (Note: Title V permit condition numbers alone are not the underlying applicable requirements). If an emission limit is calculated based on the type of source and design capacity or if a standard is based on a design parameter, this information should also be included.

From current Title V permit:

____ Permit Shield

For all applicable requirements listed above, provide monitoring/testing/recordkeeping/reporting which shall be used to demonstrate compliance. If the method is based on a permit or rule, include the condition number or citation. (Note: Each requirement listed above must have an associated method of demonstrating compliance. If there is not already a required method in place, then a method must be proposed.)

From current Title V permit:

Are you in compliance with all applicable requirements for this emission unit? Yes No

If no, complete the **Schedule of Compliance Form** as ATTACHMENT F.

ATTACHMENT E - Emission Unit Form

Emission Unit Description: *Storage Tank*

Emission unit ID number: 9814	Emission unit name: Tank 9814	List any control devices associated with this emission unit: N/A
---	---	--

Provide a description of the emission unit (type, method of operation, design parameters, etc.):
Storage tank.

Manufacturer:	Model number:	Serial number:
----------------------	----------------------	-----------------------

Construction date: See Attachment D Equipment Table	Installation date: See Attachment D Equipment Table	Modification date(s): See Attachment D Equipment Table
---	---	--

Design Capacity (examples: furnaces - tons/hr, tanks - gallons): See Attachment D Equipment Table

Maximum Hourly Throughput:	Maximum Annual Throughput:	Maximum Operating Schedule: 24 hrs/day, 365 days/yr
-----------------------------------	-----------------------------------	---

Fuel Usage Data (fill out all applicable fields)

Does this emission unit combust fuel? ___Yes ___X___ No	If yes, is it? ___ Indirect Fired ___ Direct Fired
--	--

Maximum design heat input and/or maximum horsepower rating:	Type and Btu/hr rating of burners:
--	---

List the primary fuel type(s) and if applicable, the secondary fuel type(s). For each fuel type listed, provide the maximum hourly and annual fuel usage for each.

Describe each fuel expected to be used during the term of the permit.

Fuel Type	Max. Sulfur Content	Max. Ash Content	BTU Value

<i>Emissions Data</i>		
Criteria Pollutants	Potential Emissions	
	PPH	TPY
Carbon Monoxide (CO)		
Nitrogen Oxides (NO _x)		
Lead (Pb)		
Particulate Matter (PM _{2.5})		
Particulate Matter (PM ₁₀)		
Total Particulate Matter (TSP)		
Sulfur Dioxide (SO ₂)		
Volatile Organic Compounds (VOC)		
Hazardous Air Pollutants	Potential Emissions	
	PPH	TPY
Regulated Pollutants other than Criteria and HAP	Potential Emissions	
	PPH	TPY

List the method(s) used to calculate the potential emissions (include dates of any stack tests conducted, versions of software used, source and dates of emission factors, etc.).

Applicable Requirements

List all applicable requirements for this emission unit. For each applicable requirement, include the underlying rule/regulation citation and/or construction permit with the condition number. (Note: Title V permit condition numbers alone are not the underlying applicable requirements). If an emission limit is calculated based on the type of source and design capacity or if a standard is based on a design parameter, this information should also be included.

From current Title V permit:

____ Permit Shield

For all applicable requirements listed above, provide monitoring/testing/recordkeeping/reporting which shall be used to demonstrate compliance. If the method is based on a permit or rule, include the condition number or citation. (Note: Each requirement listed above must have an associated method of demonstrating compliance. If there is not already a required method in place, then a method must be proposed.)

From current Title V permit:

Are you in compliance with all applicable requirements for this emission unit? Yes No

If no, complete the **Schedule of Compliance Form** as ATTACHMENT F.

ATTACHMENT E - Emission Unit Form

Emission Unit Description: *Storage Tank*

Emission unit ID number: 9815	Emission unit name: Tank 9815	List any control devices associated with this emission unit: N/A
---	---	--

Provide a description of the emission unit (type, method of operation, design parameters, etc.):
Storage tank.

Manufacturer:	Model number:	Serial number:
----------------------	----------------------	-----------------------

Construction date: See Attachment D Equipment Table	Installation date: See Attachment D Equipment Table	Modification date(s): See Attachment D Equipment Table
---	---	--

Design Capacity (examples: furnaces - tons/hr, tanks - gallons): See Attachment D Equipment Table

Maximum Hourly Throughput:	Maximum Annual Throughput:	Maximum Operating Schedule: 24 hrs/day, 365 days/yr
-----------------------------------	-----------------------------------	---

Fuel Usage Data (fill out all applicable fields)

Does this emission unit combust fuel? ___Yes ___X___ No	If yes, is it? ___ Indirect Fired ___ Direct Fired
--	--

Maximum design heat input and/or maximum horsepower rating:	Type and Btu/hr rating of burners:
--	---

List the primary fuel type(s) and if applicable, the secondary fuel type(s). For each fuel type listed, provide the maximum hourly and annual fuel usage for each.

Describe each fuel expected to be used during the term of the permit.

Fuel Type	Max. Sulfur Content	Max. Ash Content	BTU Value

<i>Emissions Data</i>		
Criteria Pollutants	Potential Emissions	
	PPH	TPY
Carbon Monoxide (CO)		
Nitrogen Oxides (NO _x)		
Lead (Pb)		
Particulate Matter (PM _{2.5})		
Particulate Matter (PM ₁₀)		
Total Particulate Matter (TSP)		
Sulfur Dioxide (SO ₂)		
Volatile Organic Compounds (VOC)		
Hazardous Air Pollutants	Potential Emissions	
	PPH	TPY
Regulated Pollutants other than Criteria and HAP	Potential Emissions	
	PPH	TPY

List the method(s) used to calculate the potential emissions (include dates of any stack tests conducted, versions of software used, source and dates of emission factors, etc.).

Applicable Requirements

List all applicable requirements for this emission unit. For each applicable requirement, include the underlying rule/regulation citation and/or construction permit with the condition number. (Note: Title V permit condition numbers alone are not the underlying applicable requirements). If an emission limit is calculated based on the type of source and design capacity or if a standard is based on a design parameter, this information should also be included.

From current Title V permit:

____ Permit Shield

For all applicable requirements listed above, provide monitoring/testing/recordkeeping/reporting which shall be used to demonstrate compliance. If the method is based on a permit or rule, include the condition number or citation. (Note: Each requirement listed above must have an associated method of demonstrating compliance. If there is not already a required method in place, then a method must be proposed.)

From current Title V permit:

Are you in compliance with all applicable requirements for this emission unit? Yes No

If no, complete the **Schedule of Compliance Form** as ATTACHMENT F.

ATTACHMENT E - Emission Unit Form

Emission Unit Description: *Storage Tank*

Emission unit ID number: 9821	Emission unit name: Tank 9821	List any control devices associated with this emission unit: N/A
---	---	--

Provide a description of the emission unit (type, method of operation, design parameters, etc.):

Storage tank.

Manufacturer:	Model number:	Serial number:
Construction date: See Attachment D Equipment Table	Installation date: See Attachment D Equipment Table	Modification date(s): See Attachment D Equipment Table

Design Capacity (examples: furnaces - tons/hr, tanks - gallons): See Attachment D Equipment Table

Maximum Hourly Throughput:	Maximum Annual Throughput:	Maximum Operating Schedule: 24 hrs/day, 365 days/yr
-----------------------------------	-----------------------------------	---

Fuel Usage Data (fill out all applicable fields)

Does this emission unit combust fuel? ___Yes ___X___ No	If yes, is it? ___ Indirect Fired ___ Direct Fired
--	--

Maximum design heat input and/or maximum horsepower rating:	Type and Btu/hr rating of burners:
--	---

List the primary fuel type(s) and if applicable, the secondary fuel type(s). For each fuel type listed, provide the maximum hourly and annual fuel usage for each.

Describe each fuel expected to be used during the term of the permit.

Fuel Type	Max. Sulfur Content	Max. Ash Content	BTU Value

<i>Emissions Data</i>		
Criteria Pollutants	Potential Emissions	
	PPH	TPY
Carbon Monoxide (CO)		
Nitrogen Oxides (NO _x)		
Lead (Pb)		
Particulate Matter (PM _{2.5})		
Particulate Matter (PM ₁₀)		
Total Particulate Matter (TSP)		
Sulfur Dioxide (SO ₂)		
Volatile Organic Compounds (VOC)		
Hazardous Air Pollutants	Potential Emissions	
	PPH	TPY
Regulated Pollutants other than Criteria and HAP	Potential Emissions	
	PPH	TPY

List the method(s) used to calculate the potential emissions (include dates of any stack tests conducted, versions of software used, source and dates of emission factors, etc.).

Applicable Requirements

List all applicable requirements for this emission unit. For each applicable requirement, include the underlying rule/regulation citation and/or construction permit with the condition number. (Note: Title V permit condition numbers alone are not the underlying applicable requirements). If an emission limit is calculated based on the type of source and design capacity or if a standard is based on a design parameter, this information should also be included.

From current Title V permit:

____ Permit Shield

For all applicable requirements listed above, provide monitoring/testing/recordkeeping/reporting which shall be used to demonstrate compliance. If the method is based on a permit or rule, include the condition number or citation. (Note: Each requirement listed above must have an associated method of demonstrating compliance. If there is not already a required method in place, then a method must be proposed.)

From current Title V permit:

Are you in compliance with all applicable requirements for this emission unit? Yes No

If no, complete the **Schedule of Compliance Form** as ATTACHMENT F.

ATTACHMENT E - Emission Unit Form

Emission Unit Description: *Storage Tank*

Emission unit ID number: 9822	Emission unit name: Tank 9822	List any control devices associated with this emission unit: N/A
---	---	--

Provide a description of the emission unit (type, method of operation, design parameters, etc.):
Storage tank.

Manufacturer:	Model number:	Serial number:
----------------------	----------------------	-----------------------

Construction date: See Attachment D Equipment Table	Installation date: See Attachment D Equipment Table	Modification date(s): See Attachment D Equipment Table
---	---	--

Design Capacity (examples: furnaces - tons/hr, tanks - gallons): See Attachment D Equipment Table

Maximum Hourly Throughput:	Maximum Annual Throughput:	Maximum Operating Schedule: 24 hrs/day, 365 days/yr
-----------------------------------	-----------------------------------	---

Fuel Usage Data (fill out all applicable fields)

Does this emission unit combust fuel? ___Yes ___X___ No	If yes, is it? ___ Indirect Fired ___ Direct Fired
--	--

Maximum design heat input and/or maximum horsepower rating:	Type and Btu/hr rating of burners:
--	---

List the primary fuel type(s) and if applicable, the secondary fuel type(s). For each fuel type listed, provide the maximum hourly and annual fuel usage for each.

Describe each fuel expected to be used during the term of the permit.

Fuel Type	Max. Sulfur Content	Max. Ash Content	BTU Value

<i>Emissions Data</i>		
Criteria Pollutants	Potential Emissions	
	PPH	TPY
Carbon Monoxide (CO)		
Nitrogen Oxides (NO _x)		
Lead (Pb)		
Particulate Matter (PM _{2.5})		
Particulate Matter (PM ₁₀)		
Total Particulate Matter (TSP)		
Sulfur Dioxide (SO ₂)		
Volatile Organic Compounds (VOC)		
Hazardous Air Pollutants	Potential Emissions	
	PPH	TPY
Regulated Pollutants other than Criteria and HAP	Potential Emissions	
	PPH	TPY

List the method(s) used to calculate the potential emissions (include dates of any stack tests conducted, versions of software used, source and dates of emission factors, etc.).

Applicable Requirements

List all applicable requirements for this emission unit. For each applicable requirement, include the underlying rule/regulation citation and/or construction permit with the condition number. (Note: Title V permit condition numbers alone are not the underlying applicable requirements). If an emission limit is calculated based on the type of source and design capacity or if a standard is based on a design parameter, this information should also be included.

From current Title V permit:

____ Permit Shield

For all applicable requirements listed above, provide monitoring/testing/recordkeeping/reporting which shall be used to demonstrate compliance. If the method is based on a permit or rule, include the condition number or citation. (Note: Each requirement listed above must have an associated method of demonstrating compliance. If there is not already a required method in place, then a method must be proposed.)

From current Title V permit:

Are you in compliance with all applicable requirements for this emission unit? Yes No

If no, complete the **Schedule of Compliance Form** as ATTACHMENT F.

ATTACHMENT E - Emission Unit Form

Emission Unit Description: *Storage Tank*

Emission unit ID number: 9823	Emission unit name: Tank 9823	List any control devices associated with this emission unit: N/A
---	---	--

Provide a description of the emission unit (type, method of operation, design parameters, etc.):
Storage tank.

Manufacturer:	Model number:	Serial number:
----------------------	----------------------	-----------------------

Construction date: See Attachment D Equipment Table	Installation date: See Attachment D Equipment Table	Modification date(s): See Attachment D Equipment Table
---	---	--

Design Capacity (examples: furnaces - tons/hr, tanks - gallons): See Attachment D Equipment Table

Maximum Hourly Throughput:	Maximum Annual Throughput:	Maximum Operating Schedule: 24 hrs/day, 365 days/yr
-----------------------------------	-----------------------------------	---

Fuel Usage Data (fill out all applicable fields)

Does this emission unit combust fuel? ___Yes ___X___ No	If yes, is it? ___ Indirect Fired ___ Direct Fired
--	--

Maximum design heat input and/or maximum horsepower rating:	Type and Btu/hr rating of burners:
--	---

List the primary fuel type(s) and if applicable, the secondary fuel type(s). For each fuel type listed, provide the maximum hourly and annual fuel usage for each.

Describe each fuel expected to be used during the term of the permit.

Fuel Type	Max. Sulfur Content	Max. Ash Content	BTU Value

<i>Emissions Data</i>		
Criteria Pollutants	Potential Emissions	
	PPH	TPY
Carbon Monoxide (CO)		
Nitrogen Oxides (NO _x)		
Lead (Pb)		
Particulate Matter (PM _{2.5})		
Particulate Matter (PM ₁₀)		
Total Particulate Matter (TSP)		
Sulfur Dioxide (SO ₂)		
Volatile Organic Compounds (VOC)		
Hazardous Air Pollutants	Potential Emissions	
	PPH	TPY
Regulated Pollutants other than Criteria and HAP	Potential Emissions	
	PPH	TPY

List the method(s) used to calculate the potential emissions (include dates of any stack tests conducted, versions of software used, source and dates of emission factors, etc.).

Applicable Requirements

List all applicable requirements for this emission unit. For each applicable requirement, include the underlying rule/regulation citation and/or construction permit with the condition number. (Note: Title V permit condition numbers alone are not the underlying applicable requirements). If an emission limit is calculated based on the type of source and design capacity or if a standard is based on a design parameter, this information should also be included.

From current Title V permit:

____ Permit Shield

For all applicable requirements listed above, provide monitoring/testing/recordkeeping/reporting which shall be used to demonstrate compliance. If the method is based on a permit or rule, include the condition number or citation. (Note: Each requirement listed above must have an associated method of demonstrating compliance. If there is not already a required method in place, then a method must be proposed.)

From current Title V permit:

Are you in compliance with all applicable requirements for this emission unit? Yes No

If no, complete the **Schedule of Compliance Form** as ATTACHMENT F.

ATTACHMENT E - Emission Unit Form

Emission Unit Description: *Storage Tank*

Emission unit ID number: 9824	Emission unit name: Tank 9824	List any control devices associated with this emission unit: N/A
---	---	--

Provide a description of the emission unit (type, method of operation, design parameters, etc.):
Storage tank.

Manufacturer:	Model number:	Serial number:
----------------------	----------------------	-----------------------

Construction date: See Attachment D Equipment Table	Installation date: See Attachment D Equipment Table	Modification date(s): See Attachment D Equipment Table
---	---	--

Design Capacity (examples: furnaces - tons/hr, tanks - gallons): See Attachment D Equipment Table

Maximum Hourly Throughput:	Maximum Annual Throughput:	Maximum Operating Schedule: 24 hrs/day, 365 days/yr
-----------------------------------	-----------------------------------	---

Fuel Usage Data (fill out all applicable fields)

Does this emission unit combust fuel? ___Yes ___X___ No	If yes, is it? ___ Indirect Fired ___ Direct Fired
--	--

Maximum design heat input and/or maximum horsepower rating:	Type and Btu/hr rating of burners:
--	---

List the primary fuel type(s) and if applicable, the secondary fuel type(s). For each fuel type listed, provide the maximum hourly and annual fuel usage for each.

Describe each fuel expected to be used during the term of the permit.

Fuel Type	Max. Sulfur Content	Max. Ash Content	BTU Value

<i>Emissions Data</i>		
Criteria Pollutants	Potential Emissions	
	PPH	TPY
Carbon Monoxide (CO)		
Nitrogen Oxides (NO _x)		
Lead (Pb)		
Particulate Matter (PM _{2.5})		
Particulate Matter (PM ₁₀)		
Total Particulate Matter (TSP)		
Sulfur Dioxide (SO ₂)		
Volatile Organic Compounds (VOC)		
Hazardous Air Pollutants	Potential Emissions	
	PPH	TPY
Regulated Pollutants other than Criteria and HAP	Potential Emissions	
	PPH	TPY

List the method(s) used to calculate the potential emissions (include dates of any stack tests conducted, versions of software used, source and dates of emission factors, etc.).

Applicable Requirements

List all applicable requirements for this emission unit. For each applicable requirement, include the underlying rule/regulation citation and/or construction permit with the condition number. (Note: Title V permit condition numbers alone are not the underlying applicable requirements). If an emission limit is calculated based on the type of source and design capacity or if a standard is based on a design parameter, this information should also be included.

From current Title V permit:

____ Permit Shield

For all applicable requirements listed above, provide monitoring/testing/recordkeeping/reporting which shall be used to demonstrate compliance. If the method is based on a permit or rule, include the condition number or citation. (Note: Each requirement listed above must have an associated method of demonstrating compliance. If there is not already a required method in place, then a method must be proposed.)

From current Title V permit:

Are you in compliance with all applicable requirements for this emission unit? Yes No

If no, complete the **Schedule of Compliance Form** as ATTACHMENT F.

ATTACHMENT E - Emission Unit Form

Emission Unit Description: *Storage Tank*

Emission unit ID number: 9825	Emission unit name: Tank 9825	List any control devices associated with this emission unit: N/A
---	---	--

Provide a description of the emission unit (type, method of operation, design parameters, etc.):
Storage tank.

Manufacturer:	Model number:	Serial number:
----------------------	----------------------	-----------------------

Construction date: See Attachment D Equipment Table	Installation date: See Attachment D Equipment Table	Modification date(s): See Attachment D Equipment Table
---	---	--

Design Capacity (examples: furnaces - tons/hr, tanks - gallons): See Attachment D Equipment Table

Maximum Hourly Throughput:	Maximum Annual Throughput:	Maximum Operating Schedule: 24 hrs/day, 365 days/yr
-----------------------------------	-----------------------------------	---

Fuel Usage Data (fill out all applicable fields)

Does this emission unit combust fuel? ___Yes ___X___ No	If yes, is it? ___ Indirect Fired ___ Direct Fired
--	--

Maximum design heat input and/or maximum horsepower rating:	Type and Btu/hr rating of burners:
--	---

List the primary fuel type(s) and if applicable, the secondary fuel type(s). For each fuel type listed, provide the maximum hourly and annual fuel usage for each.

Describe each fuel expected to be used during the term of the permit.

Fuel Type	Max. Sulfur Content	Max. Ash Content	BTU Value

<i>Emissions Data</i>		
Criteria Pollutants	Potential Emissions	
	PPH	TPY
Carbon Monoxide (CO)		
Nitrogen Oxides (NO _x)		
Lead (Pb)		
Particulate Matter (PM _{2.5})		
Particulate Matter (PM ₁₀)		
Total Particulate Matter (TSP)		
Sulfur Dioxide (SO ₂)		
Volatile Organic Compounds (VOC)		
Hazardous Air Pollutants	Potential Emissions	
	PPH	TPY
Regulated Pollutants other than Criteria and HAP	Potential Emissions	
	PPH	TPY

List the method(s) used to calculate the potential emissions (include dates of any stack tests conducted, versions of software used, source and dates of emission factors, etc.).

Applicable Requirements

List all applicable requirements for this emission unit. For each applicable requirement, include the underlying rule/regulation citation and/or construction permit with the condition number. (Note: Title V permit condition numbers alone are not the underlying applicable requirements). If an emission limit is calculated based on the type of source and design capacity or if a standard is based on a design parameter, this information should also be included.

From current Title V permit:

____ Permit Shield

For all applicable requirements listed above, provide monitoring/testing/recordkeeping/reporting which shall be used to demonstrate compliance. If the method is based on a permit or rule, include the condition number or citation. (Note: Each requirement listed above must have an associated method of demonstrating compliance. If there is not already a required method in place, then a method must be proposed.)

From current Title V permit:

Are you in compliance with all applicable requirements for this emission unit? Yes No

If no, complete the **Schedule of Compliance Form** as ATTACHMENT F.

ATTACHMENT E - Emission Unit Form

Emission Unit Description:

Emission unit ID number: 717R1	Emission unit name: Recovery and Refining Systems 1	List any control devices associated with this emission unit: N/A
--	---	--

Provide a description of the emission unit (type, method of operation, design parameters, etc.):

Manufacturer:	Model number:	Serial number:
----------------------	----------------------	-----------------------

Construction date: See Attachment D Equipment Table	Installation date: See Attachment D Equipment Table	Modification date(s): See Attachment D Equipment Table
---	---	--

Design Capacity (examples: furnaces - tons/hr, tanks - gallons): See Attachment D Equipment Table

Maximum Hourly Throughput:	Maximum Annual Throughput:	Maximum Operating Schedule: 24 hrs/day, 365 days/yr
-----------------------------------	-----------------------------------	---

Fuel Usage Data (fill out all applicable fields)

Does this emission unit combust fuel? <input type="checkbox"/> Yes <input checked="" type="checkbox"/> No	If yes, is it? <input type="checkbox"/> Indirect Fired <input type="checkbox"/> Direct Fired
--	--

Maximum design heat input and/or maximum horsepower rating:	Type and Btu/hr rating of burners:
--	---

List the primary fuel type(s) and if applicable, the secondary fuel type(s). For each fuel type listed, provide the maximum hourly and annual fuel usage for each.

Describe each fuel expected to be used during the term of the permit.

Fuel Type	Max. Sulfur Content	Max. Ash Content	BTU Value

<i>Emissions Data</i>		
Criteria Pollutants	Potential Emissions	
	PPH	TPY
Carbon Monoxide (CO)		
Nitrogen Oxides (NO _x)		
Lead (Pb)		
Particulate Matter (PM _{2.5})		
Particulate Matter (PM ₁₀)		
Total Particulate Matter (TSP)		
Sulfur Dioxide (SO ₂)		
Volatile Organic Compounds (VOC)		
Hazardous Air Pollutants	Potential Emissions	
	PPH	TPY
Regulated Pollutants other than Criteria and HAP	Potential Emissions	
	PPH	TPY

List the method(s) used to calculate the potential emissions (include dates of any stack tests conducted, versions of software used, source and dates of emission factors, etc.).

Applicable Requirements

List all applicable requirements for this emission unit. For each applicable requirement, include the underlying rule/regulation citation and/or construction permit with the condition number. (Note: Title V permit condition numbers alone are not the underlying applicable requirements). If an emission limit is calculated based on the type of source and design capacity or if a standard is based on a design parameter, this information should also be included.

From current Title V permit:

____ Permit Shield

For all applicable requirements listed above, provide monitoring/testing/recordkeeping/reporting which shall be used to demonstrate compliance. If the method is based on a permit or rule, include the condition number or citation. (Note: Each requirement listed above must have an associated method of demonstrating compliance. If there is not already a required method in place, then a method must be proposed.)

From current Title V permit:

Are you in compliance with all applicable requirements for this emission unit? Yes No

If no, complete the **Schedule of Compliance Form** as ATTACHMENT F.

ATTACHMENT E - Emission Unit Form

Emission Unit Description:

Emission unit ID number: 717R2	Emission unit name: Recovery and Refining Systems 2	List any control devices associated with this emission unit: N/A
--	---	--

Provide a description of the emission unit (type, method of operation, design parameters, etc.):

Manufacturer:	Model number:	Serial number:
----------------------	----------------------	-----------------------

Construction date: See Attachment D Equipment Table	Installation date: See Attachment D Equipment Table	Modification date(s): See Attachment D Equipment Table
---	---	--

Design Capacity (examples: furnaces - tons/hr, tanks - gallons): See Attachment D Equipment Table

Maximum Hourly Throughput:	Maximum Annual Throughput:	Maximum Operating Schedule: 24 hrs/day, 365 days/yr
-----------------------------------	-----------------------------------	---

Fuel Usage Data (fill out all applicable fields)

Does this emission unit combust fuel? <input type="checkbox"/> Yes <input checked="" type="checkbox"/> No	If yes, is it? <input type="checkbox"/> Indirect Fired <input type="checkbox"/> Direct Fired
--	--

Maximum design heat input and/or maximum horsepower rating:	Type and Btu/hr rating of burners:
--	---

List the primary fuel type(s) and if applicable, the secondary fuel type(s). For each fuel type listed, provide the maximum hourly and annual fuel usage for each.

Describe each fuel expected to be used during the term of the permit.

Fuel Type	Max. Sulfur Content	Max. Ash Content	BTU Value

<i>Emissions Data</i>		
Criteria Pollutants	Potential Emissions	
	PPH	TPY
Carbon Monoxide (CO)		
Nitrogen Oxides (NO _x)		
Lead (Pb)		
Particulate Matter (PM _{2.5})		
Particulate Matter (PM ₁₀)		
Total Particulate Matter (TSP)		
Sulfur Dioxide (SO ₂)		
Volatile Organic Compounds (VOC)		
Hazardous Air Pollutants	Potential Emissions	
	PPH	TPY
Regulated Pollutants other than Criteria and HAP	Potential Emissions	
	PPH	TPY

List the method(s) used to calculate the potential emissions (include dates of any stack tests conducted, versions of software used, source and dates of emission factors, etc.).

Applicable Requirements

List all applicable requirements for this emission unit. For each applicable requirement, include the underlying rule/regulation citation and/or construction permit with the condition number. (Note: Title V permit condition numbers alone are not the underlying applicable requirements). If an emission limit is calculated based on the type of source and design capacity or if a standard is based on a design parameter, this information should also be included.

From current Title V permit:

____ Permit Shield

For all applicable requirements listed above, provide monitoring/testing/recordkeeping/reporting which shall be used to demonstrate compliance. If the method is based on a permit or rule, include the condition number or citation. (Note: Each requirement listed above must have an associated method of demonstrating compliance. If there is not already a required method in place, then a method must be proposed.)

From current Title V permit:

Are you in compliance with all applicable requirements for this emission unit? Yes No

If no, complete the **Schedule of Compliance Form** as ATTACHMENT F.

ATTACHMENT E - Emission Unit Form

Emission Unit Description:

Emission unit ID number: 721T	Emission unit name: #1 Product Treatment Emission Pt. for Vacuum Jet	List any control devices associated with this emission unit: C709 and/or None
---	---	---

Provide a description of the emission unit (type, method of operation, design parameters, etc.):

Manufacturer:	Model number:	Serial number:
----------------------	----------------------	-----------------------

Construction date: See Attachment D Equipment Table	Installation date: See Attachment D Equipment Table	Modification date(s): See Attachment D Equipment Table
---	---	--

Design Capacity (examples: furnaces - tons/hr, tanks - gallons): See Attachment D Equipment Table

Maximum Hourly Throughput:	Maximum Annual Throughput:	Maximum Operating Schedule: 24 hrs/day, 365 days/yr
-----------------------------------	-----------------------------------	---

Fuel Usage Data (fill out all applicable fields)

Does this emission unit combust fuel? ___Yes ___X___ No	If yes, is it? ___ Indirect Fired ___Direct Fired
--	---

Maximum design heat input and/or maximum horsepower rating:	Type and Btu/hr rating of burners:
--	---

List the primary fuel type(s) and if applicable, the secondary fuel type(s). For each fuel type listed, provide the maximum hourly and annual fuel usage for each.

Describe each fuel expected to be used during the term of the permit.

Fuel Type	Max. Sulfur Content	Max. Ash Content	BTU Value

<i>Emissions Data</i>		
Criteria Pollutants	Potential Emissions	
	PPH	TPY
Carbon Monoxide (CO)		
Nitrogen Oxides (NO _x)		
Lead (Pb)		
Particulate Matter (PM _{2.5})		
Particulate Matter (PM ₁₀)		
Total Particulate Matter (TSP)		
Sulfur Dioxide (SO ₂)		
Volatile Organic Compounds (VOC)		
Hazardous Air Pollutants	Potential Emissions	
	PPH	TPY
Regulated Pollutants other than Criteria and HAP	Potential Emissions	
	PPH	TPY

List the method(s) used to calculate the potential emissions (include dates of any stack tests conducted, versions of software used, source and dates of emission factors, etc.).

Applicable Requirements

List all applicable requirements for this emission unit. For each applicable requirement, include the underlying rule/regulation citation and/or construction permit with the condition number. (Note: Title V permit condition numbers alone are not the underlying applicable requirements). If an emission limit is calculated based on the type of source and design capacity or if a standard is based on a design parameter, this information should also be included.

From current Title V permit:

____ Permit Shield

For all applicable requirements listed above, provide monitoring/testing/recordkeeping/reporting which shall be used to demonstrate compliance. If the method is based on a permit or rule, include the condition number or citation. (Note: Each requirement listed above must have an associated method of demonstrating compliance. If there is not already a required method in place, then a method must be proposed.)

From current Title V permit:

Are you in compliance with all applicable requirements for this emission unit? Yes No

If no, complete the **Schedule of Compliance Form** as ATTACHMENT F.

ATTACHMENT E - Emission Unit Form

Emission Unit Description:

Emission unit ID number: 722T	Emission unit name: #2 Product Treatment Emission Pt. for Vacuum Jet	List any control devices associated with this emission unit: C710 and/or None
---	---	---

Provide a description of the emission unit (type, method of operation, design parameters, etc.):

Manufacturer:	Model number:	Serial number:
----------------------	----------------------	-----------------------

Construction date: See Attachment D Equipment Table	Installation date: See Attachment D Equipment Table	Modification date(s): See Attachment D Equipment Table
---	---	--

Design Capacity (examples: furnaces - tons/hr, tanks - gallons): See Attachment D Equipment Table

Maximum Hourly Throughput:	Maximum Annual Throughput:	Maximum Operating Schedule: 24 hrs/day, 365 days/yr
-----------------------------------	-----------------------------------	---

Fuel Usage Data (fill out all applicable fields)

Does this emission unit combust fuel? ___ Yes ___X___ No	If yes, is it? ___ Indirect Fired ___ Direct Fired
---	--

Maximum design heat input and/or maximum horsepower rating:	Type and Btu/hr rating of burners:
--	---

List the primary fuel type(s) and if applicable, the secondary fuel type(s). For each fuel type listed, provide the maximum hourly and annual fuel usage for each.

Describe each fuel expected to be used during the term of the permit.

Fuel Type	Max. Sulfur Content	Max. Ash Content	BTU Value

<i>Emissions Data</i>		
Criteria Pollutants	Potential Emissions	
	PPH	TPY
Carbon Monoxide (CO)		
Nitrogen Oxides (NO _x)		
Lead (Pb)		
Particulate Matter (PM _{2.5})		
Particulate Matter (PM ₁₀)		
Total Particulate Matter (TSP)		
Sulfur Dioxide (SO ₂)		
Volatile Organic Compounds (VOC)		
Hazardous Air Pollutants	Potential Emissions	
	PPH	TPY
Regulated Pollutants other than Criteria and HAP	Potential Emissions	
	PPH	TPY

List the method(s) used to calculate the potential emissions (include dates of any stack tests conducted, versions of software used, source and dates of emission factors, etc.).

Applicable Requirements

List all applicable requirements for this emission unit. For each applicable requirement, include the underlying rule/regulation citation and/or construction permit with the condition number. (Note: Title V permit condition numbers alone are not the underlying applicable requirements). If an emission limit is calculated based on the type of source and design capacity or if a standard is based on a design parameter, this information should also be included.

From current Title V permit:

____ Permit Shield

For all applicable requirements listed above, provide monitoring/testing/recordkeeping/reporting which shall be used to demonstrate compliance. If the method is based on a permit or rule, include the condition number or citation. (Note: Each requirement listed above must have an associated method of demonstrating compliance. If there is not already a required method in place, then a method must be proposed.)

From current Title V permit:

Are you in compliance with all applicable requirements for this emission unit? Yes No

If no, complete the **Schedule of Compliance Form** as ATTACHMENT F.

ATTACHMENT E - Emission Unit Form

Emission Unit Description:

Emission unit ID number: 723T	Emission unit name: #5 Product Treatment Emission Pt. for Vacuum Jet	List any control devices associated with this emission unit: C711 and/or None
---	---	---

Provide a description of the emission unit (type, method of operation, design parameters, etc.):

Manufacturer:	Model number:	Serial number:
----------------------	----------------------	-----------------------

Construction date: See Attachment D Equipment Table	Installation date: See Attachment D Equipment Table	Modification date(s): See Attachment D Equipment Table
---	---	--

Design Capacity (examples: furnaces - tons/hr, tanks - gallons): See Attachment D Equipment Table

Maximum Hourly Throughput:	Maximum Annual Throughput:	Maximum Operating Schedule: 24 hrs/day, 365 days/yr
-----------------------------------	-----------------------------------	---

Fuel Usage Data (fill out all applicable fields)

Does this emission unit combust fuel? ___Yes ___X___ No	If yes, is it? ___ Indirect Fired ___Direct Fired
--	---

Maximum design heat input and/or maximum horsepower rating:	Type and Btu/hr rating of burners:
--	---

List the primary fuel type(s) and if applicable, the secondary fuel type(s). For each fuel type listed, provide the maximum hourly and annual fuel usage for each.

Describe each fuel expected to be used during the term of the permit.

Fuel Type	Max. Sulfur Content	Max. Ash Content	BTU Value

<i>Emissions Data</i>		
Criteria Pollutants	Potential Emissions	
	PPH	TPY
Carbon Monoxide (CO)		
Nitrogen Oxides (NO _x)		
Lead (Pb)		
Particulate Matter (PM _{2.5})		
Particulate Matter (PM ₁₀)		
Total Particulate Matter (TSP)		
Sulfur Dioxide (SO ₂)		
Volatile Organic Compounds (VOC)		
Hazardous Air Pollutants	Potential Emissions	
	PPH	TPY
Regulated Pollutants other than Criteria and HAP	Potential Emissions	
	PPH	TPY

List the method(s) used to calculate the potential emissions (include dates of any stack tests conducted, versions of software used, source and dates of emission factors, etc.).

Applicable Requirements

List all applicable requirements for this emission unit. For each applicable requirement, include the underlying rule/regulation citation and/or construction permit with the condition number. (Note: Title V permit condition numbers alone are not the underlying applicable requirements). If an emission limit is calculated based on the type of source and design capacity or if a standard is based on a design parameter, this information should also be included.

From current Title V permit:

____ Permit Shield

For all applicable requirements listed above, provide monitoring/testing/recordkeeping/reporting which shall be used to demonstrate compliance. If the method is based on a permit or rule, include the condition number or citation. (Note: Each requirement listed above must have an associated method of demonstrating compliance. If there is not already a required method in place, then a method must be proposed.)

From current Title V permit:

Are you in compliance with all applicable requirements for this emission unit? Yes No

If no, complete the **Schedule of Compliance Form** as ATTACHMENT F.

ATTACHMENT E - Emission Unit Form

Emission Unit Description:

Emission unit ID number: 730HW	Emission unit name: Hotwell System	List any control devices associated with this emission unit: N/A
--	--	--

Provide a description of the emission unit (type, method of operation, design parameters, etc.):

Manufacturer:	Model number:	Serial number:
----------------------	----------------------	-----------------------

Construction date: See Attachment D Equipment Table	Installation date: See Attachment D Equipment Table	Modification date(s): See Attachment D Equipment Table
---	---	--

Design Capacity (examples: furnaces - tons/hr, tanks - gallons): See Attachment D Equipment Table

Maximum Hourly Throughput:	Maximum Annual Throughput:	Maximum Operating Schedule: 24 hrs/day, 365 days/yr
-----------------------------------	-----------------------------------	---

Fuel Usage Data (fill out all applicable fields)

Does this emission unit combust fuel? <input type="checkbox"/> Yes <input checked="" type="checkbox"/> No	If yes, is it? <input type="checkbox"/> Indirect Fired <input type="checkbox"/> Direct Fired
--	--

Maximum design heat input and/or maximum horsepower rating:	Type and Btu/hr rating of burners:
--	---

List the primary fuel type(s) and if applicable, the secondary fuel type(s). For each fuel type listed, provide the maximum hourly and annual fuel usage for each.

Describe each fuel expected to be used during the term of the permit.

Fuel Type	Max. Sulfur Content	Max. Ash Content	BTU Value

<i>Emissions Data</i>		
Criteria Pollutants	Potential Emissions	
	PPH	TPY
Carbon Monoxide (CO)		
Nitrogen Oxides (NO _x)		
Lead (Pb)		
Particulate Matter (PM _{2.5})		
Particulate Matter (PM ₁₀)		
Total Particulate Matter (TSP)		
Sulfur Dioxide (SO ₂)		
Volatile Organic Compounds (VOC)		
Hazardous Air Pollutants	Potential Emissions	
	PPH	TPY
Regulated Pollutants other than Criteria and HAP	Potential Emissions	
	PPH	TPY

List the method(s) used to calculate the potential emissions (include dates of any stack tests conducted, versions of software used, source and dates of emission factors, etc.).

Applicable Requirements

List all applicable requirements for this emission unit. For each applicable requirement, include the underlying rule/regulation citation and/or construction permit with the condition number. (Note: Title V permit condition numbers alone are not the underlying applicable requirements). If an emission limit is calculated based on the type of source and design capacity or if a standard is based on a design parameter, this information should also be included.

From current Title V permit:

____ Permit Shield

For all applicable requirements listed above, provide monitoring/testing/recordkeeping/reporting which shall be used to demonstrate compliance. If the method is based on a permit or rule, include the condition number or citation. (Note: Each requirement listed above must have an associated method of demonstrating compliance. If there is not already a required method in place, then a method must be proposed.)

From current Title V permit:

Are you in compliance with all applicable requirements for this emission unit? Yes No

If no, complete the **Schedule of Compliance Form** as ATTACHMENT F.

ATTACHMENT E - Emission Unit Form

Emission Unit Description:

Emission unit ID number: 732T	Emission unit name: Other Treatment	List any control devices associated with this emission unit: N/A
---	---	--

Provide a description of the emission unit (type, method of operation, design parameters, etc.):

Manufacturer:	Model number:	Serial number:
----------------------	----------------------	-----------------------

Construction date: See Attachment D Equipment Table	Installation date: See Attachment D Equipment Table	Modification date(s): See Attachment D Equipment Table
---	---	--

Design Capacity (examples: furnaces - tons/hr, tanks - gallons): See Attachment D Equipment Table

Maximum Hourly Throughput:	Maximum Annual Throughput:	Maximum Operating Schedule: 24 hrs/day, 365 days/yr
-----------------------------------	-----------------------------------	---

Fuel Usage Data (fill out all applicable fields)

Does this emission unit combust fuel? <input type="checkbox"/> Yes <input checked="" type="checkbox"/> No	If yes, is it? <input type="checkbox"/> Indirect Fired <input type="checkbox"/> Direct Fired
--	--

Maximum design heat input and/or maximum horsepower rating:	Type and Btu/hr rating of burners:
--	---

List the primary fuel type(s) and if applicable, the secondary fuel type(s). For each fuel type listed, provide the maximum hourly and annual fuel usage for each.

Describe each fuel expected to be used during the term of the permit.

Fuel Type	Max. Sulfur Content	Max. Ash Content	BTU Value

<i>Emissions Data</i>		
Criteria Pollutants	Potential Emissions	
	PPH	TPY
Carbon Monoxide (CO)		
Nitrogen Oxides (NO _x)		
Lead (Pb)		
Particulate Matter (PM _{2.5})		
Particulate Matter (PM ₁₀)		
Total Particulate Matter (TSP)		
Sulfur Dioxide (SO ₂)		
Volatile Organic Compounds (VOC)		
Hazardous Air Pollutants	Potential Emissions	
	PPH	TPY
Regulated Pollutants other than Criteria and HAP	Potential Emissions	
	PPH	TPY

List the method(s) used to calculate the potential emissions (include dates of any stack tests conducted, versions of software used, source and dates of emission factors, etc.).

Applicable Requirements

List all applicable requirements for this emission unit. For each applicable requirement, include the underlying rule/regulation citation and/or construction permit with the condition number. (Note: Title V permit condition numbers alone are not the underlying applicable requirements). If an emission limit is calculated based on the type of source and design capacity or if a standard is based on a design parameter, this information should also be included.

From current Title V permit:

____ Permit Shield

For all applicable requirements listed above, provide monitoring/testing/recordkeeping/reporting which shall be used to demonstrate compliance. If the method is based on a permit or rule, include the condition number or citation. (Note: Each requirement listed above must have an associated method of demonstrating compliance. If there is not already a required method in place, then a method must be proposed.)

From current Title V permit:

Are you in compliance with all applicable requirements for this emission unit? Yes No

If no, complete the **Schedule of Compliance Form** as ATTACHMENT F.

ATTACHMENT E - Emission Unit Form

Emission Unit Description: *Condenser*

Emission unit ID number: C709	Emission unit name: #1 Jets/Condenser	List any control devices associated with this emission unit: N/A
---	---	--

Provide a description of the emission unit (type, method of operation, design parameters, etc.):

Manufacturer:	Model number:	Serial number:
----------------------	----------------------	-----------------------

Construction date: See Attachment D Equipment Table	Installation date: See Attachment D Equipment Table	Modification date(s): See Attachment D Equipment Table
---	---	--

Design Capacity (examples: furnaces - tons/hr, tanks - gallons): See Attachment D Equipment Table

Maximum Hourly Throughput:	Maximum Annual Throughput:	Maximum Operating Schedule: 24 hrs/day, 365 days/yr
-----------------------------------	-----------------------------------	---

***Fuel Usage Data* (fill out all applicable fields)**

Does this emission unit combust fuel? ___ Yes ___X___ No	If yes, is it? ___ Indirect Fired ___ Direct Fired
---	--

Maximum design heat input and/or maximum horsepower rating:	Type and Btu/hr rating of burners:
--	---

List the primary fuel type(s) and if applicable, the secondary fuel type(s). For each fuel type listed, provide the maximum hourly and annual fuel usage for each.

Describe each fuel expected to be used during the term of the permit.

Fuel Type	Max. Sulfur Content	Max. Ash Content	BTU Value

<i>Emissions Data</i>		
Criteria Pollutants	Potential Emissions	
	PPH	TPY
Carbon Monoxide (CO)		
Nitrogen Oxides (NO _x)		
Lead (Pb)		
Particulate Matter (PM _{2.5})		
Particulate Matter (PM ₁₀)		
Total Particulate Matter (TSP)		
Sulfur Dioxide (SO ₂)		
Volatile Organic Compounds (VOC)		
Hazardous Air Pollutants	Potential Emissions	
	PPH	TPY
Regulated Pollutants other than Criteria and HAP	Potential Emissions	
	PPH	TPY

List the method(s) used to calculate the potential emissions (include dates of any stack tests conducted, versions of software used, source and dates of emission factors, etc.).

Applicable Requirements

List all applicable requirements for this emission unit. For each applicable requirement, include the underlying rule/regulation citation and/or construction permit with the condition number. (Note: Title V permit condition numbers alone are not the underlying applicable requirements). If an emission limit is calculated based on the type of source and design capacity or if a standard is based on a design parameter, this information should also be included.

From current Title V permit:

____ Permit Shield

For all applicable requirements listed above, provide monitoring/testing/recordkeeping/reporting which shall be used to demonstrate compliance. If the method is based on a permit or rule, include the condition number or citation. (Note: Each requirement listed above must have an associated method of demonstrating compliance. If there is not already a required method in place, then a method must be proposed.)

From current Title V permit:

Are you in compliance with all applicable requirements for this emission unit? Yes No

If no, complete the **Schedule of Compliance Form** as ATTACHMENT F.

ATTACHMENT E - Emission Unit Form

Emission Unit Description: *Condenser*

Emission unit ID number: C710	Emission unit name: #2 Jets/Condenser	List any control devices associated with this emission unit: N/A
---	---	--

Provide a description of the emission unit (type, method of operation, design parameters, etc.):

Manufacturer:	Model number:	Serial number:
----------------------	----------------------	-----------------------

Construction date: See Attachment D Equipment Table	Installation date: See Attachment D Equipment Table	Modification date(s): See Attachment D Equipment Table
---	---	--

Design Capacity (examples: furnaces - tons/hr, tanks - gallons): See Attachment D Equipment Table

Maximum Hourly Throughput:	Maximum Annual Throughput:	Maximum Operating Schedule: 24 hrs/day, 365 days/yr
-----------------------------------	-----------------------------------	---

***Fuel Usage Data* (fill out all applicable fields)**

Does this emission unit combust fuel? ___ Yes ___X___ No	If yes, is it? ___ Indirect Fired ___ Direct Fired
---	--

Maximum design heat input and/or maximum horsepower rating:	Type and Btu/hr rating of burners:
--	---

List the primary fuel type(s) and if applicable, the secondary fuel type(s). For each fuel type listed, provide the maximum hourly and annual fuel usage for each.

Describe each fuel expected to be used during the term of the permit.

Fuel Type	Max. Sulfur Content	Max. Ash Content	BTU Value

<i>Emissions Data</i>		
Criteria Pollutants	Potential Emissions	
	PPH	TPY
Carbon Monoxide (CO)		
Nitrogen Oxides (NO _x)		
Lead (Pb)		
Particulate Matter (PM _{2.5})		
Particulate Matter (PM ₁₀)		
Total Particulate Matter (TSP)		
Sulfur Dioxide (SO ₂)		
Volatile Organic Compounds (VOC)		
Hazardous Air Pollutants	Potential Emissions	
	PPH	TPY
Regulated Pollutants other than Criteria and HAP	Potential Emissions	
	PPH	TPY

List the method(s) used to calculate the potential emissions (include dates of any stack tests conducted, versions of software used, source and dates of emission factors, etc.).

Applicable Requirements

List all applicable requirements for this emission unit. For each applicable requirement, include the underlying rule/regulation citation and/or construction permit with the condition number. (Note: Title V permit condition numbers alone are not the underlying applicable requirements). If an emission limit is calculated based on the type of source and design capacity or if a standard is based on a design parameter, this information should also be included.

From current Title V permit:

____ Permit Shield

For all applicable requirements listed above, provide monitoring/testing/recordkeeping/reporting which shall be used to demonstrate compliance. If the method is based on a permit or rule, include the condition number or citation. (Note: Each requirement listed above must have an associated method of demonstrating compliance. If there is not already a required method in place, then a method must be proposed.)

From current Title V permit:

Are you in compliance with all applicable requirements for this emission unit? Yes No

If no, complete the **Schedule of Compliance Form** as ATTACHMENT F.

ATTACHMENT E - Emission Unit Form

Emission Unit Description: *Condenser*

Emission unit ID number: C711	Emission unit name: #5 Jets/Condenser	List any control devices associated with this emission unit: N/A
---	---	--

Provide a description of the emission unit (type, method of operation, design parameters, etc.):

Manufacturer:	Model number:	Serial number:
----------------------	----------------------	-----------------------

Construction date: See Attachment D Equipment Table	Installation date: See Attachment D Equipment Table	Modification date(s): See Attachment D Equipment Table
---	---	--

Design Capacity (examples: furnaces - tons/hr, tanks - gallons): See Attachment D Equipment Table

Maximum Hourly Throughput:	Maximum Annual Throughput:	Maximum Operating Schedule: 24 hrs/day, 365 days/yr
-----------------------------------	-----------------------------------	---

Fuel Usage Data (fill out all applicable fields)

Does this emission unit combust fuel? ___ Yes ___X___ No	If yes, is it? ___ Indirect Fired ___ Direct Fired
---	--

Maximum design heat input and/or maximum horsepower rating:	Type and Btu/hr rating of burners:
--	---

List the primary fuel type(s) and if applicable, the secondary fuel type(s). For each fuel type listed, provide the maximum hourly and annual fuel usage for each.

Describe each fuel expected to be used during the term of the permit.

Fuel Type	Max. Sulfur Content	Max. Ash Content	BTU Value

<i>Emissions Data</i>		
Criteria Pollutants	Potential Emissions	
	PPH	TPY
Carbon Monoxide (CO)		
Nitrogen Oxides (NO _x)		
Lead (Pb)		
Particulate Matter (PM _{2.5})		
Particulate Matter (PM ₁₀)		
Total Particulate Matter (TSP)		
Sulfur Dioxide (SO ₂)		
Volatile Organic Compounds (VOC)		
Hazardous Air Pollutants	Potential Emissions	
	PPH	TPY
Regulated Pollutants other than Criteria and HAP	Potential Emissions	
	PPH	TPY

List the method(s) used to calculate the potential emissions (include dates of any stack tests conducted, versions of software used, source and dates of emission factors, etc.).

Applicable Requirements

List all applicable requirements for this emission unit. For each applicable requirement, include the underlying rule/regulation citation and/or construction permit with the condition number. (Note: Title V permit condition numbers alone are not the underlying applicable requirements). If an emission limit is calculated based on the type of source and design capacity or if a standard is based on a design parameter, this information should also be included.

From current Title V permit:

____ Permit Shield

For all applicable requirements listed above, provide monitoring/testing/recordkeeping/reporting which shall be used to demonstrate compliance. If the method is based on a permit or rule, include the condition number or citation. (Note: Each requirement listed above must have an associated method of demonstrating compliance. If there is not already a required method in place, then a method must be proposed.)

From current Title V permit:

Are you in compliance with all applicable requirements for this emission unit? Yes No

If no, complete the **Schedule of Compliance Form** as ATTACHMENT F.

ATTACHMENT E - Emission Unit Form

Emission Unit Description: *Transfer Rack*

Emission unit ID number: L001	Emission unit name: Tank Truck Rack	List any control devices associated with this emission unit: N/A
---	---	--

Provide a description of the emission unit (type, method of operation, design parameters, etc.):

Manufacturer:	Model number:	Serial number:
----------------------	----------------------	-----------------------

Construction date: See Attachment D Equipment Table	Installation date: See Attachment D Equipment Table	Modification date(s): See Attachment D Equipment Table
---	---	--

Design Capacity (examples: furnaces - tons/hr, tanks - gallons): See Attachment D Equipment Table

Maximum Hourly Throughput:	Maximum Annual Throughput:	Maximum Operating Schedule: 24 hrs/day, 365 days/yr
-----------------------------------	-----------------------------------	---

Fuel Usage Data (fill out all applicable fields)

Does this emission unit combust fuel? ___Yes ___X___ No	If yes, is it? ___ Indirect Fired ___Direct Fired
--	---

Maximum design heat input and/or maximum horsepower rating:	Type and Btu/hr rating of burners:
--	---

List the primary fuel type(s) and if applicable, the secondary fuel type(s). For each fuel type listed, provide the maximum hourly and annual fuel usage for each.

Describe each fuel expected to be used during the term of the permit.

Fuel Type	Max. Sulfur Content	Max. Ash Content	BTU Value

<i>Emissions Data</i>		
Criteria Pollutants	Potential Emissions	
	PPH	TPY
Carbon Monoxide (CO)		
Nitrogen Oxides (NO _x)		
Lead (Pb)		
Particulate Matter (PM _{2.5})		
Particulate Matter (PM ₁₀)		
Total Particulate Matter (TSP)		
Sulfur Dioxide (SO ₂)		
Volatile Organic Compounds (VOC)		
Hazardous Air Pollutants	Potential Emissions	
	PPH	TPY
Regulated Pollutants other than Criteria and HAP	Potential Emissions	
	PPH	TPY

List the method(s) used to calculate the potential emissions (include dates of any stack tests conducted, versions of software used, source and dates of emission factors, etc.).

Applicable Requirements

List all applicable requirements for this emission unit. For each applicable requirement, include the underlying rule/regulation citation and/or construction permit with the condition number. (Note: Title V permit condition numbers alone are not the underlying applicable requirements). If an emission limit is calculated based on the type of source and design capacity or if a standard is based on a design parameter, this information should also be included.

From current Title V permit:

____ Permit Shield

For all applicable requirements listed above, provide monitoring/testing/recordkeeping/reporting which shall be used to demonstrate compliance. If the method is based on a permit or rule, include the condition number or citation. (Note: Each requirement listed above must have an associated method of demonstrating compliance. If there is not already a required method in place, then a method must be proposed.)

From current Title V permit:

Are you in compliance with all applicable requirements for this emission unit? Yes No

If no, complete the **Schedule of Compliance Form** as ATTACHMENT F.

ATTACHMENT E - Emission Unit Form

Emission Unit Description: *Transfer Rack*

Emission unit ID number: L002	Emission unit name: Rail Car Rack	List any control devices associated with this emission unit: N/A
---	---	--

Provide a description of the emission unit (type, method of operation, design parameters, etc.):

Manufacturer:	Model number:	Serial number:
----------------------	----------------------	-----------------------

Construction date: See Attachment D Equipment Table	Installation date: See Attachment D Equipment Table	Modification date(s): See Attachment D Equipment Table
---	---	--

Design Capacity (examples: furnaces - tons/hr, tanks - gallons): See Attachment D Equipment Table

Maximum Hourly Throughput:	Maximum Annual Throughput:	Maximum Operating Schedule: 24 hrs/day, 365 days/yr
-----------------------------------	-----------------------------------	---

Fuel Usage Data (fill out all applicable fields)

Does this emission unit combust fuel? ___Yes ___X___ No	If yes, is it? ___ Indirect Fired ___Direct Fired
--	---

Maximum design heat input and/or maximum horsepower rating:	Type and Btu/hr rating of burners:
--	---

List the primary fuel type(s) and if applicable, the secondary fuel type(s). For each fuel type listed, provide the maximum hourly and annual fuel usage for each.

Describe each fuel expected to be used during the term of the permit.

Fuel Type	Max. Sulfur Content	Max. Ash Content	BTU Value

<i>Emissions Data</i>		
Criteria Pollutants	Potential Emissions	
	PPH	TPY
Carbon Monoxide (CO)		
Nitrogen Oxides (NO _x)		
Lead (Pb)		
Particulate Matter (PM _{2.5})		
Particulate Matter (PM ₁₀)		
Total Particulate Matter (TSP)		
Sulfur Dioxide (SO ₂)		
Volatile Organic Compounds (VOC)		
Hazardous Air Pollutants	Potential Emissions	
	PPH	TPY
Regulated Pollutants other than Criteria and HAP	Potential Emissions	
	PPH	TPY

List the method(s) used to calculate the potential emissions (include dates of any stack tests conducted, versions of software used, source and dates of emission factors, etc.).

Applicable Requirements

List all applicable requirements for this emission unit. For each applicable requirement, include the underlying rule/regulation citation and/or construction permit with the condition number. (Note: Title V permit condition numbers alone are not the underlying applicable requirements). If an emission limit is calculated based on the type of source and design capacity or if a standard is based on a design parameter, this information should also be included.

From current Title V permit:

____ Permit Shield

For all applicable requirements listed above, provide monitoring/testing/recordkeeping/reporting which shall be used to demonstrate compliance. If the method is based on a permit or rule, include the condition number or citation. (Note: Each requirement listed above must have an associated method of demonstrating compliance. If there is not already a required method in place, then a method must be proposed.)

From current Title V permit:

Are you in compliance with all applicable requirements for this emission unit? Yes No

If no, complete the **Schedule of Compliance Form** as ATTACHMENT F.

ATTACHMENT E - Emission Unit Form

Emission Unit Description: *Storage Tank*

Emission unit ID number: Misc Drop Tanks 1	Emission unit name: R27 CO Process ID E703A	List any control devices associated with this emission unit: N/A
--	---	--

Provide a description of the emission unit (type, method of operation, design parameters, etc.):
Reactor drop tanks

Manufacturer:	Model number:	Serial number:
----------------------	----------------------	-----------------------

Construction date: See Attachment D Equipment Table	Installation date: See Attachment D Equipment Table	Modification date(s): See Attachment D Equipment Table
---	---	--

Design Capacity (examples: furnaces - tons/hr, tanks - gallons): See Attachment D Equipment Table

Maximum Hourly Throughput:	Maximum Annual Throughput:	Maximum Operating Schedule: 24 hrs/day, 365 days/yr
-----------------------------------	-----------------------------------	---

Fuel Usage Data (fill out all applicable fields)

Does this emission unit combust fuel? ___Yes ___X___ No	If yes, is it? ___ Indirect Fired ___Direct Fired
--	---

Maximum design heat input and/or maximum horsepower rating:	Type and Btu/hr rating of burners:
--	---

List the primary fuel type(s) and if applicable, the secondary fuel type(s). For each fuel type listed, provide the maximum hourly and annual fuel usage for each.

Describe each fuel expected to be used during the term of the permit.

Fuel Type	Max. Sulfur Content	Max. Ash Content	BTU Value

<i>Emissions Data</i>		
Criteria Pollutants	Potential Emissions	
	PPH	TPY
Carbon Monoxide (CO)		
Nitrogen Oxides (NO _x)		
Lead (Pb)		
Particulate Matter (PM _{2.5})		
Particulate Matter (PM ₁₀)		
Total Particulate Matter (TSP)		
Sulfur Dioxide (SO ₂)		
Volatile Organic Compounds (VOC)		
Hazardous Air Pollutants	Potential Emissions	
	PPH	TPY
Regulated Pollutants other than Criteria and HAP	Potential Emissions	
	PPH	TPY

List the method(s) used to calculate the potential emissions (include dates of any stack tests conducted, versions of software used, source and dates of emission factors, etc.).

Applicable Requirements

List all applicable requirements for this emission unit. For each applicable requirement, include the underlying rule/regulation citation and/or construction permit with the condition number. (Note: Title V permit condition numbers alone are not the underlying applicable requirements). If an emission limit is calculated based on the type of source and design capacity or if a standard is based on a design parameter, this information should also be included.

From current Title V permit:

____ Permit Shield

For all applicable requirements listed above, provide monitoring/testing/recordkeeping/reporting which shall be used to demonstrate compliance. If the method is based on a permit or rule, include the condition number or citation. (Note: Each requirement listed above must have an associated method of demonstrating compliance. If there is not already a required method in place, then a method must be proposed.)

From current Title V permit:

Are you in compliance with all applicable requirements for this emission unit? Yes No

If no, complete the **Schedule of Compliance Form** as ATTACHMENT F.

ATTACHMENT E - Emission Unit Form

Emission Unit Description: *Storage Tank*

Emission unit ID number: Misc Drop Tanks 2	Emission unit name: R27 CO Process ID E704A	List any control devices associated with this emission unit: N/A
--	---	--

Provide a description of the emission unit (type, method of operation, design parameters, etc.):
Reactor drop tanks

Manufacturer:	Model number:	Serial number:
----------------------	----------------------	-----------------------

Construction date: See Attachment D Equipment Table	Installation date: See Attachment D Equipment Table	Modification date(s): See Attachment D Equipment Table
---	---	--

Design Capacity (examples: furnaces - tons/hr, tanks - gallons): See Attachment D Equipment Table

Maximum Hourly Throughput:	Maximum Annual Throughput:	Maximum Operating Schedule: 24 hrs/day, 365 days/yr
-----------------------------------	-----------------------------------	---

Fuel Usage Data (fill out all applicable fields)

Does this emission unit combust fuel? ___Yes ___X___ No	If yes, is it? ___ Indirect Fired ___Direct Fired
--	---

Maximum design heat input and/or maximum horsepower rating:	Type and Btu/hr rating of burners:
--	---

List the primary fuel type(s) and if applicable, the secondary fuel type(s). For each fuel type listed, provide the maximum hourly and annual fuel usage for each.

Describe each fuel expected to be used during the term of the permit.

Fuel Type	Max. Sulfur Content	Max. Ash Content	BTU Value

<i>Emissions Data</i>		
Criteria Pollutants	Potential Emissions	
	PPH	TPY
Carbon Monoxide (CO)		
Nitrogen Oxides (NO _x)		
Lead (Pb)		
Particulate Matter (PM _{2.5})		
Particulate Matter (PM ₁₀)		
Total Particulate Matter (TSP)		
Sulfur Dioxide (SO ₂)		
Volatile Organic Compounds (VOC)		
Hazardous Air Pollutants	Potential Emissions	
	PPH	TPY
Regulated Pollutants other than Criteria and HAP	Potential Emissions	
	PPH	TPY

List the method(s) used to calculate the potential emissions (include dates of any stack tests conducted, versions of software used, source and dates of emission factors, etc.).

Applicable Requirements

List all applicable requirements for this emission unit. For each applicable requirement, include the underlying rule/regulation citation and/or construction permit with the condition number. (Note: Title V permit condition numbers alone are not the underlying applicable requirements). If an emission limit is calculated based on the type of source and design capacity or if a standard is based on a design parameter, this information should also be included.

From current Title V permit:

____ Permit Shield

For all applicable requirements listed above, provide monitoring/testing/recordkeeping/reporting which shall be used to demonstrate compliance. If the method is based on a permit or rule, include the condition number or citation. (Note: Each requirement listed above must have an associated method of demonstrating compliance. If there is not already a required method in place, then a method must be proposed.)

From current Title V permit:

Are you in compliance with all applicable requirements for this emission unit? Yes No

If no, complete the **Schedule of Compliance Form** as ATTACHMENT F.

ATTACHMENT E - Emission Unit Form

Emission Unit Description: *Storage Tank*

Emission unit ID number: Misc Drop Tanks 4	Emission unit name: R27 CO Process ID E705A	List any control devices associated with this emission unit: N/A
--	---	--

Provide a description of the emission unit (type, method of operation, design parameters, etc.):
Reactor drop tanks

Manufacturer:	Model number:	Serial number:
----------------------	----------------------	-----------------------

Construction date: See Attachment D Equipment Table	Installation date: See Attachment D Equipment Table	Modification date(s): See Attachment D Equipment Table
---	---	--

Design Capacity (examples: furnaces - tons/hr, tanks - gallons): See Attachment D Equipment Table

Maximum Hourly Throughput:	Maximum Annual Throughput:	Maximum Operating Schedule: 24 hrs/day, 365 days/yr
-----------------------------------	-----------------------------------	---

Fuel Usage Data (fill out all applicable fields)

Does this emission unit combust fuel? ___Yes ___X___ No	If yes, is it? ___ Indirect Fired ___Direct Fired
--	---

Maximum design heat input and/or maximum horsepower rating:	Type and Btu/hr rating of burners:
--	---

List the primary fuel type(s) and if applicable, the secondary fuel type(s). For each fuel type listed, provide the maximum hourly and annual fuel usage for each.

Describe each fuel expected to be used during the term of the permit.

Fuel Type	Max. Sulfur Content	Max. Ash Content	BTU Value

<i>Emissions Data</i>		
Criteria Pollutants	Potential Emissions	
	PPH	TPY
Carbon Monoxide (CO)		
Nitrogen Oxides (NO _x)		
Lead (Pb)		
Particulate Matter (PM _{2.5})		
Particulate Matter (PM ₁₀)		
Total Particulate Matter (TSP)		
Sulfur Dioxide (SO ₂)		
Volatile Organic Compounds (VOC)		
Hazardous Air Pollutants	Potential Emissions	
	PPH	TPY
Regulated Pollutants other than Criteria and HAP	Potential Emissions	
	PPH	TPY

List the method(s) used to calculate the potential emissions (include dates of any stack tests conducted, versions of software used, source and dates of emission factors, etc.).

Applicable Requirements

List all applicable requirements for this emission unit. For each applicable requirement, include the underlying rule/regulation citation and/or construction permit with the condition number. (Note: Title V permit condition numbers alone are not the underlying applicable requirements). If an emission limit is calculated based on the type of source and design capacity or if a standard is based on a design parameter, this information should also be included.

From current Title V permit:

____ Permit Shield

For all applicable requirements listed above, provide monitoring/testing/recordkeeping/reporting which shall be used to demonstrate compliance. If the method is based on a permit or rule, include the condition number or citation. (Note: Each requirement listed above must have an associated method of demonstrating compliance. If there is not already a required method in place, then a method must be proposed.)

From current Title V permit:

Are you in compliance with all applicable requirements for this emission unit? Yes No

If no, complete the **Schedule of Compliance Form** as ATTACHMENT F.

ATTACHMENT E - Emission Unit Form

Emission Unit Description: *Storage Tank*

Emission unit ID number: Misc Drop Tanks 5	Emission unit name: R27 CO Process ID E706A	List any control devices associated with this emission unit: N/A
--	---	--

Provide a description of the emission unit (type, method of operation, design parameters, etc.):
Reactor drop tanks

Manufacturer:	Model number:	Serial number:
----------------------	----------------------	-----------------------

Construction date: See Attachment D Equipment Table	Installation date: See Attachment D Equipment Table	Modification date(s): See Attachment D Equipment Table
---	---	--

Design Capacity (examples: furnaces - tons/hr, tanks - gallons): See Attachment D Equipment Table

Maximum Hourly Throughput:	Maximum Annual Throughput:	Maximum Operating Schedule: 24 hrs/day, 365 days/yr
-----------------------------------	-----------------------------------	---

Fuel Usage Data (fill out all applicable fields)

Does this emission unit combust fuel? ___Yes ___X_ No	If yes, is it? ___ Indirect Fired ___Direct Fired
--	---

Maximum design heat input and/or maximum horsepower rating:	Type and Btu/hr rating of burners:
--	---

List the primary fuel type(s) and if applicable, the secondary fuel type(s). For each fuel type listed, provide the maximum hourly and annual fuel usage for each.

Describe each fuel expected to be used during the term of the permit.

Fuel Type	Max. Sulfur Content	Max. Ash Content	BTU Value

<i>Emissions Data</i>		
Criteria Pollutants	Potential Emissions	
	PPH	TPY
Carbon Monoxide (CO)		
Nitrogen Oxides (NO _x)		
Lead (Pb)		
Particulate Matter (PM _{2.5})		
Particulate Matter (PM ₁₀)		
Total Particulate Matter (TSP)		
Sulfur Dioxide (SO ₂)		
Volatile Organic Compounds (VOC)		
Hazardous Air Pollutants	Potential Emissions	
	PPH	TPY
Regulated Pollutants other than Criteria and HAP	Potential Emissions	
	PPH	TPY

List the method(s) used to calculate the potential emissions (include dates of any stack tests conducted, versions of software used, source and dates of emission factors, etc.).

Applicable Requirements

List all applicable requirements for this emission unit. For each applicable requirement, include the underlying rule/regulation citation and/or construction permit with the condition number. (Note: Title V permit condition numbers alone are not the underlying applicable requirements). If an emission limit is calculated based on the type of source and design capacity or if a standard is based on a design parameter, this information should also be included.

From current Title V permit:

____ Permit Shield

For all applicable requirements listed above, provide monitoring/testing/recordkeeping/reporting which shall be used to demonstrate compliance. If the method is based on a permit or rule, include the condition number or citation. (Note: Each requirement listed above must have an associated method of demonstrating compliance. If there is not already a required method in place, then a method must be proposed.)

From current Title V permit:

Are you in compliance with all applicable requirements for this emission unit? Yes No

If no, complete the **Schedule of Compliance Form** as ATTACHMENT F.

ATTACHMENT E - Emission Unit Form

Emission Unit Description: *Storage Tank*

Emission unit ID number: Misc Drop Tanks 6	Emission unit name: R27 CO Process ID E708A	List any control devices associated with this emission unit: N/A
--	---	--

Provide a description of the emission unit (type, method of operation, design parameters, etc.):
Reactor drop tanks

Manufacturer:	Model number:	Serial number:
----------------------	----------------------	-----------------------

Construction date: See Attachment D Equipment Table	Installation date: See Attachment D Equipment Table	Modification date(s): See Attachment D Equipment Table
---	---	--

Design Capacity (examples: furnaces - tons/hr, tanks - gallons): See Attachment D Equipment Table

Maximum Hourly Throughput:	Maximum Annual Throughput:	Maximum Operating Schedule: 24 hrs/day, 365 days/yr
-----------------------------------	-----------------------------------	---

Fuel Usage Data (fill out all applicable fields)

Does this emission unit combust fuel? ___Yes ___X_ No	If yes, is it? ___ Indirect Fired ___Direct Fired
--	---

Maximum design heat input and/or maximum horsepower rating:	Type and Btu/hr rating of burners:
--	---

List the primary fuel type(s) and if applicable, the secondary fuel type(s). For each fuel type listed, provide the maximum hourly and annual fuel usage for each.

Describe each fuel expected to be used during the term of the permit.

Fuel Type	Max. Sulfur Content	Max. Ash Content	BTU Value

<i>Emissions Data</i>		
Criteria Pollutants	Potential Emissions	
	PPH	TPY
Carbon Monoxide (CO)		
Nitrogen Oxides (NO _x)		
Lead (Pb)		
Particulate Matter (PM _{2.5})		
Particulate Matter (PM ₁₀)		
Total Particulate Matter (TSP)		
Sulfur Dioxide (SO ₂)		
Volatile Organic Compounds (VOC)		
Hazardous Air Pollutants	Potential Emissions	
	PPH	TPY
Regulated Pollutants other than Criteria and HAP	Potential Emissions	
	PPH	TPY

List the method(s) used to calculate the potential emissions (include dates of any stack tests conducted, versions of software used, source and dates of emission factors, etc.).

Applicable Requirements

List all applicable requirements for this emission unit. For each applicable requirement, include the underlying rule/regulation citation and/or construction permit with the condition number. (Note: Title V permit condition numbers alone are not the underlying applicable requirements). If an emission limit is calculated based on the type of source and design capacity or if a standard is based on a design parameter, this information should also be included.

From current Title V permit:

____ Permit Shield

For all applicable requirements listed above, provide monitoring/testing/recordkeeping/reporting which shall be used to demonstrate compliance. If the method is based on a permit or rule, include the condition number or citation. (Note: Each requirement listed above must have an associated method of demonstrating compliance. If there is not already a required method in place, then a method must be proposed.)

From current Title V permit:

Are you in compliance with all applicable requirements for this emission unit? Yes No

If no, complete the **Schedule of Compliance Form** as ATTACHMENT F.

ATTACHMENT E - Emission Unit Form

Emission Unit Description: *Storage Tank*

Emission unit ID number: Misc Drop Tanks 7	Emission unit name: R27 CO Process ID E707A	List any control devices associated with this emission unit: N/A
--	---	--

Provide a description of the emission unit (type, method of operation, design parameters, etc.):
Reactor drop tanks

Manufacturer:	Model number:	Serial number:
----------------------	----------------------	-----------------------

Construction date: See Attachment D Equipment Table	Installation date: See Attachment D Equipment Table	Modification date(s): See Attachment D Equipment Table
---	---	--

Design Capacity (examples: furnaces - tons/hr, tanks - gallons): See Attachment D Equipment Table

Maximum Hourly Throughput:	Maximum Annual Throughput:	Maximum Operating Schedule: 24 hrs/day, 365 days/yr
-----------------------------------	-----------------------------------	---

Fuel Usage Data (fill out all applicable fields)

Does this emission unit combust fuel? ___Yes ___X___ No	If yes, is it? ___ Indirect Fired ___ Direct Fired
--	--

Maximum design heat input and/or maximum horsepower rating:	Type and Btu/hr rating of burners:
--	---

List the primary fuel type(s) and if applicable, the secondary fuel type(s). For each fuel type listed, provide the maximum hourly and annual fuel usage for each.

Describe each fuel expected to be used during the term of the permit.

Fuel Type	Max. Sulfur Content	Max. Ash Content	BTU Value

<i>Emissions Data</i>		
Criteria Pollutants	Potential Emissions	
	PPH	TPY
Carbon Monoxide (CO)		
Nitrogen Oxides (NO _x)		
Lead (Pb)		
Particulate Matter (PM _{2.5})		
Particulate Matter (PM ₁₀)		
Total Particulate Matter (TSP)		
Sulfur Dioxide (SO ₂)		
Volatile Organic Compounds (VOC)		
Hazardous Air Pollutants	Potential Emissions	
	PPH	TPY
Regulated Pollutants other than Criteria and HAP	Potential Emissions	
	PPH	TPY

List the method(s) used to calculate the potential emissions (include dates of any stack tests conducted, versions of software used, source and dates of emission factors, etc.).

Applicable Requirements

List all applicable requirements for this emission unit. For each applicable requirement, include the underlying rule/regulation citation and/or construction permit with the condition number. (Note: Title V permit condition numbers alone are not the underlying applicable requirements). If an emission limit is calculated based on the type of source and design capacity or if a standard is based on a design parameter, this information should also be included.

From current Title V permit:

____ Permit Shield

For all applicable requirements listed above, provide monitoring/testing/recordkeeping/reporting which shall be used to demonstrate compliance. If the method is based on a permit or rule, include the condition number or citation. (Note: Each requirement listed above must have an associated method of demonstrating compliance. If there is not already a required method in place, then a method must be proposed.)

From current Title V permit:

Are you in compliance with all applicable requirements for this emission unit? Yes No

If no, complete the **Schedule of Compliance Form** as ATTACHMENT F.

ATTACHMENT E - Emission Unit Form

Emission Unit Description:

Emission unit ID number: P700	Emission unit name: Prep System 1	List any control devices associated with this emission unit: N/A
---	---	--

Provide a description of the emission unit (type, method of operation, design parameters, etc.):

Manufacturer:	Model number:	Serial number:
----------------------	----------------------	-----------------------

Construction date: See Attachment D Equipment Table	Installation date: See Attachment D Equipment Table	Modification date(s): See Attachment D Equipment Table
---	---	--

Design Capacity (examples: furnaces - tons/hr, tanks - gallons): See Attachment D Equipment Table

Maximum Hourly Throughput:	Maximum Annual Throughput:	Maximum Operating Schedule: 24 hrs/day, 365 days/yr
-----------------------------------	-----------------------------------	---

Fuel Usage Data (fill out all applicable fields)

Does this emission unit combust fuel? <input type="checkbox"/> Yes <input checked="" type="checkbox"/> No	If yes, is it? <input type="checkbox"/> Indirect Fired <input type="checkbox"/> Direct Fired
--	--

Maximum design heat input and/or maximum horsepower rating:	Type and Btu/hr rating of burners:
--	---

List the primary fuel type(s) and if applicable, the secondary fuel type(s). For each fuel type listed, provide the maximum hourly and annual fuel usage for each.

Describe each fuel expected to be used during the term of the permit.

Fuel Type	Max. Sulfur Content	Max. Ash Content	BTU Value

<i>Emissions Data</i>		
Criteria Pollutants	Potential Emissions	
	PPH	TPY
Carbon Monoxide (CO)		
Nitrogen Oxides (NO _x)		
Lead (Pb)		
Particulate Matter (PM _{2.5})		
Particulate Matter (PM ₁₀)		
Total Particulate Matter (TSP)		
Sulfur Dioxide (SO ₂)		
Volatile Organic Compounds (VOC)		
Hazardous Air Pollutants	Potential Emissions	
	PPH	TPY
Regulated Pollutants other than Criteria and HAP	Potential Emissions	
	PPH	TPY

List the method(s) used to calculate the potential emissions (include dates of any stack tests conducted, versions of software used, source and dates of emission factors, etc.).

Applicable Requirements

List all applicable requirements for this emission unit. For each applicable requirement, include the underlying rule/regulation citation and/or construction permit with the condition number. (Note: Title V permit condition numbers alone are not the underlying applicable requirements). If an emission limit is calculated based on the type of source and design capacity or if a standard is based on a design parameter, this information should also be included.

From current Title V permit:

____ Permit Shield

For all applicable requirements listed above, provide monitoring/testing/recordkeeping/reporting which shall be used to demonstrate compliance. If the method is based on a permit or rule, include the condition number or citation. (Note: Each requirement listed above must have an associated method of demonstrating compliance. If there is not already a required method in place, then a method must be proposed.)

From current Title V permit:

Are you in compliance with all applicable requirements for this emission unit? Yes No

If no, complete the **Schedule of Compliance Form** as ATTACHMENT F.

ATTACHMENT E - Emission Unit Form

Emission Unit Description:

Emission unit ID number: P701	Emission unit name: Prep System 2	List any control devices associated with this emission unit: N/A
---	---	--

Provide a description of the emission unit (type, method of operation, design parameters, etc.):

Manufacturer:	Model number:	Serial number:
----------------------	----------------------	-----------------------

Construction date: See Attachment D Equipment Table	Installation date: See Attachment D Equipment Table	Modification date(s): See Attachment D Equipment Table
---	---	--

Design Capacity (examples: furnaces - tons/hr, tanks - gallons): See Attachment D Equipment Table

Maximum Hourly Throughput:	Maximum Annual Throughput:	Maximum Operating Schedule: 24 hrs/day, 365 days/yr
-----------------------------------	-----------------------------------	---

Fuel Usage Data (fill out all applicable fields)

Does this emission unit combust fuel? ___Yes ___X_ No	If yes, is it? ___ Indirect Fired ___Direct Fired
--	---

Maximum design heat input and/or maximum horsepower rating:	Type and Btu/hr rating of burners:
--	---

List the primary fuel type(s) and if applicable, the secondary fuel type(s). For each fuel type listed, provide the maximum hourly and annual fuel usage for each.

Describe each fuel expected to be used during the term of the permit.

Fuel Type	Max. Sulfur Content	Max. Ash Content	BTU Value

<i>Emissions Data</i>		
Criteria Pollutants	Potential Emissions	
	PPH	TPY
Carbon Monoxide (CO)		
Nitrogen Oxides (NO _x)		
Lead (Pb)		
Particulate Matter (PM _{2.5})		
Particulate Matter (PM ₁₀)		
Total Particulate Matter (TSP)		
Sulfur Dioxide (SO ₂)		
Volatile Organic Compounds (VOC)		
Hazardous Air Pollutants	Potential Emissions	
	PPH	TPY
Regulated Pollutants other than Criteria and HAP	Potential Emissions	
	PPH	TPY

List the method(s) used to calculate the potential emissions (include dates of any stack tests conducted, versions of software used, source and dates of emission factors, etc.).

Applicable Requirements

List all applicable requirements for this emission unit. For each applicable requirement, include the underlying rule/regulation citation and/or construction permit with the condition number. (Note: Title V permit condition numbers alone are not the underlying applicable requirements). If an emission limit is calculated based on the type of source and design capacity or if a standard is based on a design parameter, this information should also be included.

From current Title V permit:

____ Permit Shield

For all applicable requirements listed above, provide monitoring/testing/recordkeeping/reporting which shall be used to demonstrate compliance. If the method is based on a permit or rule, include the condition number or citation. (Note: Each requirement listed above must have an associated method of demonstrating compliance. If there is not already a required method in place, then a method must be proposed.)

From current Title V permit:

Are you in compliance with all applicable requirements for this emission unit? Yes No

If no, complete the **Schedule of Compliance Form** as ATTACHMENT F.

ATTACHMENT E - Emission Unit Form

Emission Unit Description:

Emission unit ID number: P716	Emission unit name: Prep System 3	List any control devices associated with this emission unit: N/A
---	---	--

Provide a description of the emission unit (type, method of operation, design parameters, etc.):

Manufacturer:	Model number:	Serial number:
----------------------	----------------------	-----------------------

Construction date: See Attachment D Equipment Table	Installation date: See Attachment D Equipment Table	Modification date(s): See Attachment D Equipment Table
---	---	--

Design Capacity (examples: furnaces - tons/hr, tanks - gallons): See Attachment D Equipment Table

Maximum Hourly Throughput:	Maximum Annual Throughput:	Maximum Operating Schedule: 24 hrs/day, 365 days/yr
-----------------------------------	-----------------------------------	---

Fuel Usage Data (fill out all applicable fields)

Does this emission unit combust fuel? <input type="checkbox"/> Yes <input checked="" type="checkbox"/> No	If yes, is it? <input type="checkbox"/> Indirect Fired <input type="checkbox"/> Direct Fired
--	--

Maximum design heat input and/or maximum horsepower rating:	Type and Btu/hr rating of burners:
--	---

List the primary fuel type(s) and if applicable, the secondary fuel type(s). For each fuel type listed, provide the maximum hourly and annual fuel usage for each.

Describe each fuel expected to be used during the term of the permit.

Fuel Type	Max. Sulfur Content	Max. Ash Content	BTU Value

<i>Emissions Data</i>		
Criteria Pollutants	Potential Emissions	
	PPH	TPY
Carbon Monoxide (CO)		
Nitrogen Oxides (NO _x)		
Lead (Pb)		
Particulate Matter (PM _{2.5})		
Particulate Matter (PM ₁₀)		
Total Particulate Matter (TSP)		
Sulfur Dioxide (SO ₂)		
Volatile Organic Compounds (VOC)		
Hazardous Air Pollutants	Potential Emissions	
	PPH	TPY
Regulated Pollutants other than Criteria and HAP	Potential Emissions	
	PPH	TPY

List the method(s) used to calculate the potential emissions (include dates of any stack tests conducted, versions of software used, source and dates of emission factors, etc.).

Applicable Requirements

List all applicable requirements for this emission unit. For each applicable requirement, include the underlying rule/regulation citation and/or construction permit with the condition number. (Note: Title V permit condition numbers alone are not the underlying applicable requirements). If an emission limit is calculated based on the type of source and design capacity or if a standard is based on a design parameter, this information should also be included.

From current Title V permit:

____ Permit Shield

For all applicable requirements listed above, provide monitoring/testing/recordkeeping/reporting which shall be used to demonstrate compliance. If the method is based on a permit or rule, include the condition number or citation. (Note: Each requirement listed above must have an associated method of demonstrating compliance. If there is not already a required method in place, then a method must be proposed.)

From current Title V permit:

Are you in compliance with all applicable requirements for this emission unit? Yes No

If no, complete the **Schedule of Compliance Form** as ATTACHMENT F.

ATTACHMENT E - Emission Unit Form

Emission Unit Description:

Emission unit ID number: Product Treatment 1,2,5 and or Other Treatment 1	Emission unit name: R27 CO Process ID E703B Virtual because can treat products from reactor 1 in treater 2 or 5	List any control devices associated with this emission unit: N/A
--	---	---

Provide a description of the emission unit (type, method of operation, design parameters, etc.):
 E703B – Virtual Emission Point for #1 Reactor Product Treatment

Manufacturer:	Model number:	Serial number:
----------------------	----------------------	-----------------------

Construction date: See Attachment D Equipment Table	Installation date: See Attachment D Equipment Table	Modification date(s): See Attachment D Equipment Table
---	--	--

Design Capacity (examples: furnaces - tons/hr, tanks - gallons): See Attachment D Equipment Table

Maximum Hourly Throughput:	Maximum Annual Throughput:	Maximum Operating Schedule: 24 hrs/day, 365 days/yr
-----------------------------------	-----------------------------------	---

Fuel Usage Data (fill out all applicable fields)

Does this emission unit combust fuel? ___Yes ___X_ No	If yes, is it? ___ Indirect Fired ___Direct Fired
--	---

Maximum design heat input and/or maximum horsepower rating:	Type and Btu/hr rating of burners:
--	---

List the primary fuel type(s) and if applicable, the secondary fuel type(s). For each fuel type listed, provide the maximum hourly and annual fuel usage for each.

Describe each fuel expected to be used during the term of the permit.

Fuel Type	Max. Sulfur Content	Max. Ash Content	BTU Value

<i>Emissions Data</i>		
Criteria Pollutants	Potential Emissions	
	PPH	TPY
Carbon Monoxide (CO)		
Nitrogen Oxides (NO _x)		
Lead (Pb)		
Particulate Matter (PM _{2.5})		
Particulate Matter (PM ₁₀)		
Total Particulate Matter (TSP)		
Sulfur Dioxide (SO ₂)		
Volatile Organic Compounds (VOC)		
Hazardous Air Pollutants	Potential Emissions	
	PPH	TPY
Regulated Pollutants other than Criteria and HAP	Potential Emissions	
	PPH	TPY

List the method(s) used to calculate the potential emissions (include dates of any stack tests conducted, versions of software used, source and dates of emission factors, etc.).

Applicable Requirements

List all applicable requirements for this emission unit. For each applicable requirement, include the underlying rule/regulation citation and/or construction permit with the condition number. (Note: Title V permit condition numbers alone are not the underlying applicable requirements). If an emission limit is calculated based on the type of source and design capacity or if a standard is based on a design parameter, this information should also be included.

From current Title V permit:

____ Permit Shield

For all applicable requirements listed above, provide monitoring/testing/recordkeeping/reporting which shall be used to demonstrate compliance. If the method is based on a permit or rule, include the condition number or citation. (Note: Each requirement listed above must have an associated method of demonstrating compliance. If there is not already a required method in place, then a method must be proposed.)

From current Title V permit:

Are you in compliance with all applicable requirements for this emission unit? Yes No

If no, complete the **Schedule of Compliance Form** as ATTACHMENT F.

ATTACHMENT E - Emission Unit Form

Emission Unit Description:

Emission unit ID number: Product Treatment 1,2,5 and or Other Treatment 2	Emission unit name: R27 CO Process ID E704B	List any control devices associated with this emission unit: N/A
--	---	--

Provide a description of the emission unit (type, method of operation, design parameters, etc.):
E704B – Virtual Emission Point for #2 Reactor Product Treatment

Manufacturer:	Model number:	Serial number:
----------------------	----------------------	-----------------------

Construction date: See Attachment D Equipment Table	Installation date: See Attachment D Equipment Table	Modification date(s): See Attachment D Equipment Table
---	--	--

Design Capacity (examples: furnaces - tons/hr, tanks - gallons): See Attachment D Equipment Table

Maximum Hourly Throughput:	Maximum Annual Throughput:	Maximum Operating Schedule: 24 hrs/day, 365 days/yr
-----------------------------------	-----------------------------------	---

Fuel Usage Data (fill out all applicable fields)

Does this emission unit combust fuel? ___Yes ___X___ No	If yes, is it? ___ Indirect Fired ___Direct Fired
--	---

Maximum design heat input and/or maximum horsepower rating:	Type and Btu/hr rating of burners:
--	---

List the primary fuel type(s) and if applicable, the secondary fuel type(s). For each fuel type listed, provide the maximum hourly and annual fuel usage for each.

Describe each fuel expected to be used during the term of the permit.

Fuel Type	Max. Sulfur Content	Max. Ash Content	BTU Value

<i>Emissions Data</i>		
Criteria Pollutants	Potential Emissions	
	PPH	TPY
Carbon Monoxide (CO)		
Nitrogen Oxides (NO _x)		
Lead (Pb)		
Particulate Matter (PM _{2.5})		
Particulate Matter (PM ₁₀)		
Total Particulate Matter (TSP)		
Sulfur Dioxide (SO ₂)		
Volatile Organic Compounds (VOC)		
Hazardous Air Pollutants	Potential Emissions	
	PPH	TPY
Regulated Pollutants other than Criteria and HAP	Potential Emissions	
	PPH	TPY

List the method(s) used to calculate the potential emissions (include dates of any stack tests conducted, versions of software used, source and dates of emission factors, etc.).

Applicable Requirements

List all applicable requirements for this emission unit. For each applicable requirement, include the underlying rule/regulation citation and/or construction permit with the condition number. (Note: Title V permit condition numbers alone are not the underlying applicable requirements). If an emission limit is calculated based on the type of source and design capacity or if a standard is based on a design parameter, this information should also be included.

From current Title V permit:

____ Permit Shield

For all applicable requirements listed above, provide monitoring/testing/recordkeeping/reporting which shall be used to demonstrate compliance. If the method is based on a permit or rule, include the condition number or citation. (Note: Each requirement listed above must have an associated method of demonstrating compliance. If there is not already a required method in place, then a method must be proposed.)

From current Title V permit:

Are you in compliance with all applicable requirements for this emission unit? Yes No

If no, complete the **Schedule of Compliance Form** as ATTACHMENT F.

ATTACHMENT E - Emission Unit Form

Emission Unit Description:

Emission unit ID number: Product Treatment 1,2,5 and or Other Treatment 4	Emission unit name: R27 CO Process ID E705B	List any control devices associated with this emission unit: N/A
--	---	--

Provide a description of the emission unit (type, method of operation, design parameters, etc.):
E705B – Virtual Emission Point for #4 Reactor Product Treatment

Manufacturer:	Model number:	Serial number:
----------------------	----------------------	-----------------------

Construction date: See Attachment D Equipment Table	Installation date: See Attachment D Equipment Table	Modification date(s): See Attachment D Equipment Table
---	--	--

Design Capacity (examples: furnaces - tons/hr, tanks - gallons): See Attachment D Equipment Table

Maximum Hourly Throughput:	Maximum Annual Throughput:	Maximum Operating Schedule: 24 hrs/day, 365 days/yr
-----------------------------------	-----------------------------------	---

Fuel Usage Data (fill out all applicable fields)

Does this emission unit combust fuel? ___Yes ___X___ No	If yes, is it? ___ Indirect Fired ___Direct Fired
--	---

Maximum design heat input and/or maximum horsepower rating:	Type and Btu/hr rating of burners:
--	---

List the primary fuel type(s) and if applicable, the secondary fuel type(s). For each fuel type listed, provide the maximum hourly and annual fuel usage for each.

Describe each fuel expected to be used during the term of the permit.

Fuel Type	Max. Sulfur Content	Max. Ash Content	BTU Value

<i>Emissions Data</i>		
Criteria Pollutants	Potential Emissions	
	PPH	TPY
Carbon Monoxide (CO)		
Nitrogen Oxides (NO _x)		
Lead (Pb)		
Particulate Matter (PM _{2.5})		
Particulate Matter (PM ₁₀)		
Total Particulate Matter (TSP)		
Sulfur Dioxide (SO ₂)		
Volatile Organic Compounds (VOC)		
Hazardous Air Pollutants	Potential Emissions	
	PPH	TPY
Regulated Pollutants other than Criteria and HAP	Potential Emissions	
	PPH	TPY

List the method(s) used to calculate the potential emissions (include dates of any stack tests conducted, versions of software used, source and dates of emission factors, etc.).

Applicable Requirements

List all applicable requirements for this emission unit. For each applicable requirement, include the underlying rule/regulation citation and/or construction permit with the condition number. (Note: Title V permit condition numbers alone are not the underlying applicable requirements). If an emission limit is calculated based on the type of source and design capacity or if a standard is based on a design parameter, this information should also be included.

From current Title V permit:

____ Permit Shield

For all applicable requirements listed above, provide monitoring/testing/recordkeeping/reporting which shall be used to demonstrate compliance. If the method is based on a permit or rule, include the condition number or citation. (Note: Each requirement listed above must have an associated method of demonstrating compliance. If there is not already a required method in place, then a method must be proposed.)

From current Title V permit:

Are you in compliance with all applicable requirements for this emission unit? Yes No

If no, complete the **Schedule of Compliance Form** as ATTACHMENT F.

ATTACHMENT E - Emission Unit Form

Emission Unit Description:

Emission unit ID number: Product Treatment 1,2,5 and or Other Treatment 5	Emission unit name: R27 CO Process ID E706B	List any control devices associated with this emission unit: N/A
--	---	--

Provide a description of the emission unit (type, method of operation, design parameters, etc.):
 E706B – Virtual Emission Point for #5 Reactor Product Treatment

Manufacturer:	Model number:	Serial number:
----------------------	----------------------	-----------------------

Construction date: See Attachment D Equipment Table	Installation date: See Attachment D Equipment Table	Modification date(s): See Attachment D Equipment Table
---	---	--

Design Capacity (examples: furnaces - tons/hr, tanks - gallons): See Attachment D Equipment Table

Maximum Hourly Throughput:	Maximum Annual Throughput:	Maximum Operating Schedule: 24 hrs/day, 365 days/yr
-----------------------------------	-----------------------------------	---

Fuel Usage Data (fill out all applicable fields)

Does this emission unit combust fuel? ___Yes ___X_ No	If yes, is it? ___ Indirect Fired ___Direct Fired
--	---

Maximum design heat input and/or maximum horsepower rating:	Type and Btu/hr rating of burners:
--	---

List the primary fuel type(s) and if applicable, the secondary fuel type(s). For each fuel type listed, provide the maximum hourly and annual fuel usage for each.

Describe each fuel expected to be used during the term of the permit.

Fuel Type	Max. Sulfur Content	Max. Ash Content	BTU Value

<i>Emissions Data</i>		
Criteria Pollutants	Potential Emissions	
	PPH	TPY
Carbon Monoxide (CO)		
Nitrogen Oxides (NO _x)		
Lead (Pb)		
Particulate Matter (PM _{2.5})		
Particulate Matter (PM ₁₀)		
Total Particulate Matter (TSP)		
Sulfur Dioxide (SO ₂)		
Volatile Organic Compounds (VOC)		
Hazardous Air Pollutants	Potential Emissions	
	PPH	TPY
Regulated Pollutants other than Criteria and HAP	Potential Emissions	
	PPH	TPY

List the method(s) used to calculate the potential emissions (include dates of any stack tests conducted, versions of software used, source and dates of emission factors, etc.).

Applicable Requirements

List all applicable requirements for this emission unit. For each applicable requirement, include the underlying rule/regulation citation and/or construction permit with the condition number. (Note: Title V permit condition numbers alone are not the underlying applicable requirements). If an emission limit is calculated based on the type of source and design capacity or if a standard is based on a design parameter, this information should also be included.

From current Title V permit:

____ Permit Shield

For all applicable requirements listed above, provide monitoring/testing/recordkeeping/reporting which shall be used to demonstrate compliance. If the method is based on a permit or rule, include the condition number or citation. (Note: Each requirement listed above must have an associated method of demonstrating compliance. If there is not already a required method in place, then a method must be proposed.)

From current Title V permit:

Are you in compliance with all applicable requirements for this emission unit? Yes No

If no, complete the **Schedule of Compliance Form** as ATTACHMENT F.

ATTACHMENT E - Emission Unit Form

Emission Unit Description:

Emission unit ID number: Product Treatment 1,2,5 and or Other Treatment 6	Emission unit name: R27 CO Process ID E708B	List any control devices associated with this emission unit: N/A
--	---	--

Provide a description of the emission unit (type, method of operation, design parameters, etc.):
E708B – Virtual Emission Point for #6 Reactor Product Treatment

Manufacturer:	Model number:	Serial number:
----------------------	----------------------	-----------------------

Construction date: See Attachment D Equipment Table	Installation date: See Attachment D Equipment Table	Modification date(s): See Attachment D Equipment Table
---	--	--

Design Capacity (examples: furnaces - tons/hr, tanks - gallons): See Attachment D Equipment Table

Maximum Hourly Throughput:	Maximum Annual Throughput:	Maximum Operating Schedule: 24 hrs/day, 365 days/yr
-----------------------------------	-----------------------------------	---

Fuel Usage Data (fill out all applicable fields)

Does this emission unit combust fuel? ___Yes ___X___ No	If yes, is it? ___ Indirect Fired ___Direct Fired
--	---

Maximum design heat input and/or maximum horsepower rating:	Type and Btu/hr rating of burners:
--	---

List the primary fuel type(s) and if applicable, the secondary fuel type(s). For each fuel type listed, provide the maximum hourly and annual fuel usage for each.

Describe each fuel expected to be used during the term of the permit.

Fuel Type	Max. Sulfur Content	Max. Ash Content	BTU Value

<i>Emissions Data</i>		
Criteria Pollutants	Potential Emissions	
	PPH	TPY
Carbon Monoxide (CO)		
Nitrogen Oxides (NO _x)		
Lead (Pb)		
Particulate Matter (PM _{2.5})		
Particulate Matter (PM ₁₀)		
Total Particulate Matter (TSP)		
Sulfur Dioxide (SO ₂)		
Volatile Organic Compounds (VOC)		
Hazardous Air Pollutants	Potential Emissions	
	PPH	TPY
Regulated Pollutants other than Criteria and HAP	Potential Emissions	
	PPH	TPY

List the method(s) used to calculate the potential emissions (include dates of any stack tests conducted, versions of software used, source and dates of emission factors, etc.).

Applicable Requirements

List all applicable requirements for this emission unit. For each applicable requirement, include the underlying rule/regulation citation and/or construction permit with the condition number. (Note: Title V permit condition numbers alone are not the underlying applicable requirements). If an emission limit is calculated based on the type of source and design capacity or if a standard is based on a design parameter, this information should also be included.

From current Title V permit:

____ Permit Shield

For all applicable requirements listed above, provide monitoring/testing/recordkeeping/reporting which shall be used to demonstrate compliance. If the method is based on a permit or rule, include the condition number or citation. (Note: Each requirement listed above must have an associated method of demonstrating compliance. If there is not already a required method in place, then a method must be proposed.)

From current Title V permit:

Are you in compliance with all applicable requirements for this emission unit? Yes No

If no, complete the **Schedule of Compliance Form** as ATTACHMENT F.

ATTACHMENT E - Emission Unit Form

Emission Unit Description:

Emission unit ID number: Product Treatment 1,2,5 and or Other Treatment 7	Emission unit name: R27 CO Process ID E707B	List any control devices associated with this emission unit: N/A
--	---	--

Provide a description of the emission unit (type, method of operation, design parameters, etc.):
E708B - Virtual Emission Point for #6 Reactor Product Treatment

Manufacturer:	Model number:	Serial number:
----------------------	----------------------	-----------------------

Construction date: See Attachment D Equipment Table	Installation date: See Attachment D Equipment Table	Modification date(s): See Attachment D Equipment Table
---	--	--

Design Capacity (examples: furnaces - tons/hr, tanks - gallons): See Attachment D Equipment Table

Maximum Hourly Throughput:	Maximum Annual Throughput:	Maximum Operating Schedule: 24 hrs/day, 365 days/yr
-----------------------------------	-----------------------------------	---

Fuel Usage Data (fill out all applicable fields)

Does this emission unit combust fuel? ___Yes ___X_ No	If yes, is it? ___ Indirect Fired ___Direct Fired
--	---

Maximum design heat input and/or maximum horsepower rating:	Type and Btu/hr rating of burners:
--	---

List the primary fuel type(s) and if applicable, the secondary fuel type(s). For each fuel type listed, provide the maximum hourly and annual fuel usage for each.

Describe each fuel expected to be used during the term of the permit.

Fuel Type	Max. Sulfur Content	Max. Ash Content	BTU Value

<i>Emissions Data</i>		
Criteria Pollutants	Potential Emissions	
	PPH	TPY
Carbon Monoxide (CO)		
Nitrogen Oxides (NO _x)		
Lead (Pb)		
Particulate Matter (PM _{2.5})		
Particulate Matter (PM ₁₀)		
Total Particulate Matter (TSP)		
Sulfur Dioxide (SO ₂)		
Volatile Organic Compounds (VOC)		
Hazardous Air Pollutants	Potential Emissions	
	PPH	TPY
Regulated Pollutants other than Criteria and HAP	Potential Emissions	
	PPH	TPY

List the method(s) used to calculate the potential emissions (include dates of any stack tests conducted, versions of software used, source and dates of emission factors, etc.).

Applicable Requirements

List all applicable requirements for this emission unit. For each applicable requirement, include the underlying rule/regulation citation and/or construction permit with the condition number. (Note: Title V permit condition numbers alone are not the underlying applicable requirements). If an emission limit is calculated based on the type of source and design capacity or if a standard is based on a design parameter, this information should also be included.

From current Title V permit:

____ Permit Shield

For all applicable requirements listed above, provide monitoring/testing/recordkeeping/reporting which shall be used to demonstrate compliance. If the method is based on a permit or rule, include the condition number or citation. (Note: Each requirement listed above must have an associated method of demonstrating compliance. If there is not already a required method in place, then a method must be proposed.)

From current Title V permit:

Are you in compliance with all applicable requirements for this emission unit? Yes No

If no, complete the **Schedule of Compliance Form** as ATTACHMENT F.

ATTACHMENT E - Emission Unit Form

Emission Unit Description: *Reactor*

Emission unit ID number: R703	Emission unit name: Reactor 1	List any control devices associated with this emission unit: N/A
---	---	--

Provide a description of the emission unit (type, method of operation, design parameters, etc.):

Manufacturer:	Model number:	Serial number:
----------------------	----------------------	-----------------------

Construction date: See Attachment D Equipment Table	Installation date: See Attachment D Equipment Table	Modification date(s): See Attachment D Equipment Table
---	---	--

Design Capacity (examples: furnaces - tons/hr, tanks - gallons): See Attachment D Equipment Table

Maximum Hourly Throughput:	Maximum Annual Throughput:	Maximum Operating Schedule: 24 hrs/day, 365 days/yr
-----------------------------------	-----------------------------------	---

***Fuel Usage Data* (fill out all applicable fields)**

Does this emission unit combust fuel? ___Yes ___X___ No	If yes, is it? ___ Indirect Fired ___Direct Fired
--	---

Maximum design heat input and/or maximum horsepower rating:	Type and Btu/hr rating of burners:
--	---

List the primary fuel type(s) and if applicable, the secondary fuel type(s). For each fuel type listed, provide the maximum hourly and annual fuel usage for each.

Describe each fuel expected to be used during the term of the permit.

Fuel Type	Max. Sulfur Content	Max. Ash Content	BTU Value

<i>Emissions Data</i>		
Criteria Pollutants	Potential Emissions	
	PPH	TPY
Carbon Monoxide (CO)		
Nitrogen Oxides (NO _x)		
Lead (Pb)		
Particulate Matter (PM _{2.5})		
Particulate Matter (PM ₁₀)		
Total Particulate Matter (TSP)		
Sulfur Dioxide (SO ₂)		
Volatile Organic Compounds (VOC)		
Hazardous Air Pollutants	Potential Emissions	
	PPH	TPY
Regulated Pollutants other than Criteria and HAP	Potential Emissions	
	PPH	TPY

List the method(s) used to calculate the potential emissions (include dates of any stack tests conducted, versions of software used, source and dates of emission factors, etc.).

Applicable Requirements

List all applicable requirements for this emission unit. For each applicable requirement, include the underlying rule/regulation citation and/or construction permit with the condition number. (Note: Title V permit condition numbers alone are not the underlying applicable requirements). If an emission limit is calculated based on the type of source and design capacity or if a standard is based on a design parameter, this information should also be included.

From current Title V permit:

____ Permit Shield

For all applicable requirements listed above, provide monitoring/testing/recordkeeping/reporting which shall be used to demonstrate compliance. If the method is based on a permit or rule, include the condition number or citation. (Note: Each requirement listed above must have an associated method of demonstrating compliance. If there is not already a required method in place, then a method must be proposed.)

From current Title V permit:

Are you in compliance with all applicable requirements for this emission unit? Yes No

If no, complete the **Schedule of Compliance Form** as ATTACHMENT F.

ATTACHMENT E - Emission Unit Form

Emission Unit Description: *Reactor*

Emission unit ID number: R704	Emission unit name: Reactor 2	List any control devices associated with this emission unit: N/A
---	---	--

Provide a description of the emission unit (type, method of operation, design parameters, etc.):

Manufacturer:	Model number:	Serial number:
----------------------	----------------------	-----------------------

Construction date: See Attachment D Equipment Table	Installation date: See Attachment D Equipment Table	Modification date(s): See Attachment D Equipment Table
---	---	--

Design Capacity (examples: furnaces - tons/hr, tanks - gallons): See Attachment D Equipment Table

Maximum Hourly Throughput:	Maximum Annual Throughput:	Maximum Operating Schedule: 24 hrs/day, 365 days/yr
-----------------------------------	-----------------------------------	---

***Fuel Usage Data* (fill out all applicable fields)**

Does this emission unit combust fuel? ___Yes ___X___ No	If yes, is it? ___ Indirect Fired ___Direct Fired
--	---

Maximum design heat input and/or maximum horsepower rating:	Type and Btu/hr rating of burners:
--	---

List the primary fuel type(s) and if applicable, the secondary fuel type(s). For each fuel type listed, provide the maximum hourly and annual fuel usage for each.

Describe each fuel expected to be used during the term of the permit.

Fuel Type	Max. Sulfur Content	Max. Ash Content	BTU Value

<i>Emissions Data</i>		
Criteria Pollutants	Potential Emissions	
	PPH	TPY
Carbon Monoxide (CO)		
Nitrogen Oxides (NO _x)		
Lead (Pb)		
Particulate Matter (PM _{2.5})		
Particulate Matter (PM ₁₀)		
Total Particulate Matter (TSP)		
Sulfur Dioxide (SO ₂)		
Volatile Organic Compounds (VOC)		
Hazardous Air Pollutants	Potential Emissions	
	PPH	TPY
Regulated Pollutants other than Criteria and HAP	Potential Emissions	
	PPH	TPY

List the method(s) used to calculate the potential emissions (include dates of any stack tests conducted, versions of software used, source and dates of emission factors, etc.).

Applicable Requirements

List all applicable requirements for this emission unit. For each applicable requirement, include the underlying rule/regulation citation and/or construction permit with the condition number. (Note: Title V permit condition numbers alone are not the underlying applicable requirements). If an emission limit is calculated based on the type of source and design capacity or if a standard is based on a design parameter, this information should also be included.

From current Title V permit:

____ Permit Shield

For all applicable requirements listed above, provide monitoring/testing/recordkeeping/reporting which shall be used to demonstrate compliance. If the method is based on a permit or rule, include the condition number or citation. (Note: Each requirement listed above must have an associated method of demonstrating compliance. If there is not already a required method in place, then a method must be proposed.)

From current Title V permit:

Are you in compliance with all applicable requirements for this emission unit? Yes No

If no, complete the **Schedule of Compliance Form** as ATTACHMENT F.

ATTACHMENT E - Emission Unit Form

Emission Unit Description: *Reactor*

Emission unit ID number: R705	Emission unit name: Reactor 4	List any control devices associated with this emission unit: N/A
---	---	--

Provide a description of the emission unit (type, method of operation, design parameters, etc.):

Manufacturer:	Model number:	Serial number:
----------------------	----------------------	-----------------------

Construction date: See Attachment D Equipment Table	Installation date: See Attachment D Equipment Table	Modification date(s): See Attachment D Equipment Table
---	---	--

Design Capacity (examples: furnaces - tons/hr, tanks - gallons): See Attachment D Equipment Table

Maximum Hourly Throughput:	Maximum Annual Throughput:	Maximum Operating Schedule: 24 hrs/day, 365 days/yr
-----------------------------------	-----------------------------------	---

***Fuel Usage Data* (fill out all applicable fields)**

Does this emission unit combust fuel? <input type="checkbox"/> Yes <input checked="" type="checkbox"/> No	If yes, is it? <input type="checkbox"/> Indirect Fired <input type="checkbox"/> Direct Fired
--	--

Maximum design heat input and/or maximum horsepower rating:	Type and Btu/hr rating of burners:
--	---

List the primary fuel type(s) and if applicable, the secondary fuel type(s). For each fuel type listed, provide the maximum hourly and annual fuel usage for each.

Describe each fuel expected to be used during the term of the permit.

Fuel Type	Max. Sulfur Content	Max. Ash Content	BTU Value

<i>Emissions Data</i>		
Criteria Pollutants	Potential Emissions	
	PPH	TPY
Carbon Monoxide (CO)		
Nitrogen Oxides (NO _x)		
Lead (Pb)		
Particulate Matter (PM _{2.5})		
Particulate Matter (PM ₁₀)		
Total Particulate Matter (TSP)		
Sulfur Dioxide (SO ₂)		
Volatile Organic Compounds (VOC)		
Hazardous Air Pollutants	Potential Emissions	
	PPH	TPY
Regulated Pollutants other than Criteria and HAP	Potential Emissions	
	PPH	TPY

List the method(s) used to calculate the potential emissions (include dates of any stack tests conducted, versions of software used, source and dates of emission factors, etc.).

Applicable Requirements

List all applicable requirements for this emission unit. For each applicable requirement, include the underlying rule/regulation citation and/or construction permit with the condition number. (Note: Title V permit condition numbers alone are not the underlying applicable requirements). If an emission limit is calculated based on the type of source and design capacity or if a standard is based on a design parameter, this information should also be included.

From current Title V permit:

____ Permit Shield

For all applicable requirements listed above, provide monitoring/testing/recordkeeping/reporting which shall be used to demonstrate compliance. If the method is based on a permit or rule, include the condition number or citation. (Note: Each requirement listed above must have an associated method of demonstrating compliance. If there is not already a required method in place, then a method must be proposed.)

From current Title V permit:

Are you in compliance with all applicable requirements for this emission unit? Yes No

If no, complete the **Schedule of Compliance Form** as ATTACHMENT F.

ATTACHMENT E - Emission Unit Form

Emission Unit Description: *Reactor*

Emission unit ID number: R706	Emission unit name: Reactor 5	List any control devices associated with this emission unit: N/A
---	---	--

Provide a description of the emission unit (type, method of operation, design parameters, etc.):

Manufacturer:	Model number:	Serial number:
----------------------	----------------------	-----------------------

Construction date: See Attachment D Equipment Table	Installation date: See Attachment D Equipment Table	Modification date(s): See Attachment D Equipment Table
---	---	--

Design Capacity (examples: furnaces - tons/hr, tanks - gallons): See Attachment D Equipment Table

Maximum Hourly Throughput:	Maximum Annual Throughput:	Maximum Operating Schedule: 24 hrs/day, 365 days/yr
-----------------------------------	-----------------------------------	---

***Fuel Usage Data* (fill out all applicable fields)**

Does this emission unit combust fuel? <input type="checkbox"/> Yes <input checked="" type="checkbox"/> No	If yes, is it? <input type="checkbox"/> Indirect Fired <input type="checkbox"/> Direct Fired
--	--

Maximum design heat input and/or maximum horsepower rating:	Type and Btu/hr rating of burners:
--	---

List the primary fuel type(s) and if applicable, the secondary fuel type(s). For each fuel type listed, provide the maximum hourly and annual fuel usage for each.

Describe each fuel expected to be used during the term of the permit.

Fuel Type	Max. Sulfur Content	Max. Ash Content	BTU Value

<i>Emissions Data</i>		
Criteria Pollutants	Potential Emissions	
	PPH	TPY
Carbon Monoxide (CO)		
Nitrogen Oxides (NO _x)		
Lead (Pb)		
Particulate Matter (PM _{2.5})		
Particulate Matter (PM ₁₀)		
Total Particulate Matter (TSP)		
Sulfur Dioxide (SO ₂)		
Volatile Organic Compounds (VOC)		
Hazardous Air Pollutants	Potential Emissions	
	PPH	TPY
Regulated Pollutants other than Criteria and HAP	Potential Emissions	
	PPH	TPY

List the method(s) used to calculate the potential emissions (include dates of any stack tests conducted, versions of software used, source and dates of emission factors, etc.).

Applicable Requirements

List all applicable requirements for this emission unit. For each applicable requirement, include the underlying rule/regulation citation and/or construction permit with the condition number. (Note: Title V permit condition numbers alone are not the underlying applicable requirements). If an emission limit is calculated based on the type of source and design capacity or if a standard is based on a design parameter, this information should also be included.

From current Title V permit:

____ Permit Shield

For all applicable requirements listed above, provide monitoring/testing/recordkeeping/reporting which shall be used to demonstrate compliance. If the method is based on a permit or rule, include the condition number or citation. (Note: Each requirement listed above must have an associated method of demonstrating compliance. If there is not already a required method in place, then a method must be proposed.)

From current Title V permit:

Are you in compliance with all applicable requirements for this emission unit? Yes No

If no, complete the **Schedule of Compliance Form** as ATTACHMENT F.

ATTACHMENT E - Emission Unit Form

Emission Unit Description: *Reactor*

Emission unit ID number: R707	Emission unit name: Reactor 7	List any control devices associated with this emission unit: N/A
---	---	--

Provide a description of the emission unit (type, method of operation, design parameters, etc.):

Manufacturer:	Model number:	Serial number:
----------------------	----------------------	-----------------------

Construction date: See Attachment D Equipment Table	Installation date: See Attachment D Equipment Table	Modification date(s): See Attachment D Equipment Table
---	---	--

Design Capacity (examples: furnaces - tons/hr, tanks - gallons): See Attachment D Equipment Table

Maximum Hourly Throughput:	Maximum Annual Throughput:	Maximum Operating Schedule: 24 hrs/day, 365 days/yr
-----------------------------------	-----------------------------------	---

***Fuel Usage Data* (fill out all applicable fields)**

Does this emission unit combust fuel? ___Yes ___X___ No	If yes, is it? ___ Indirect Fired ___Direct Fired
--	---

Maximum design heat input and/or maximum horsepower rating:	Type and Btu/hr rating of burners:
--	---

List the primary fuel type(s) and if applicable, the secondary fuel type(s). For each fuel type listed, provide the maximum hourly and annual fuel usage for each.

Describe each fuel expected to be used during the term of the permit.

Fuel Type	Max. Sulfur Content	Max. Ash Content	BTU Value

<i>Emissions Data</i>		
Criteria Pollutants	Potential Emissions	
	PPH	TPY
Carbon Monoxide (CO)		
Nitrogen Oxides (NO _x)		
Lead (Pb)		
Particulate Matter (PM _{2.5})		
Particulate Matter (PM ₁₀)		
Total Particulate Matter (TSP)		
Sulfur Dioxide (SO ₂)		
Volatile Organic Compounds (VOC)		
Hazardous Air Pollutants	Potential Emissions	
	PPH	TPY
Regulated Pollutants other than Criteria and HAP	Potential Emissions	
	PPH	TPY

List the method(s) used to calculate the potential emissions (include dates of any stack tests conducted, versions of software used, source and dates of emission factors, etc.).

Applicable Requirements

List all applicable requirements for this emission unit. For each applicable requirement, include the underlying rule/regulation citation and/or construction permit with the condition number. (Note: Title V permit condition numbers alone are not the underlying applicable requirements). If an emission limit is calculated based on the type of source and design capacity or if a standard is based on a design parameter, this information should also be included.

From current Title V permit:

____ Permit Shield

For all applicable requirements listed above, provide monitoring/testing/recordkeeping/reporting which shall be used to demonstrate compliance. If the method is based on a permit or rule, include the condition number or citation. (Note: Each requirement listed above must have an associated method of demonstrating compliance. If there is not already a required method in place, then a method must be proposed.)

From current Title V permit:

Are you in compliance with all applicable requirements for this emission unit? Yes No

If no, complete the **Schedule of Compliance Form** as ATTACHMENT F.

ATTACHMENT E - Emission Unit Form

Emission Unit Description: *Reactor*

Emission unit ID number: R708	Emission unit name: Reactor 6	List any control devices associated with this emission unit: N/A
---	---	--

Provide a description of the emission unit (type, method of operation, design parameters, etc.):

Manufacturer:	Model number:	Serial number:
----------------------	----------------------	-----------------------

Construction date: See Attachment D Equipment Table	Installation date: See Attachment D Equipment Table	Modification date(s): See Attachment D Equipment Table
---	---	--

Design Capacity (examples: furnaces - tons/hr, tanks - gallons): See Attachment D Equipment Table

Maximum Hourly Throughput:	Maximum Annual Throughput:	Maximum Operating Schedule: 24 hrs/day, 365 days/yr
-----------------------------------	-----------------------------------	---

***Fuel Usage Data* (fill out all applicable fields)**

Does this emission unit combust fuel? ___Yes ___X___ No	If yes, is it? ___ Indirect Fired ___Direct Fired
--	---

Maximum design heat input and/or maximum horsepower rating:	Type and Btu/hr rating of burners:
--	---

List the primary fuel type(s) and if applicable, the secondary fuel type(s). For each fuel type listed, provide the maximum hourly and annual fuel usage for each.

Describe each fuel expected to be used during the term of the permit.

Fuel Type	Max. Sulfur Content	Max. Ash Content	BTU Value

<i>Emissions Data</i>		
Criteria Pollutants	Potential Emissions	
	PPH	TPY
Carbon Monoxide (CO)		
Nitrogen Oxides (NO _x)		
Lead (Pb)		
Particulate Matter (PM _{2.5})		
Particulate Matter (PM ₁₀)		
Total Particulate Matter (TSP)		
Sulfur Dioxide (SO ₂)		
Volatile Organic Compounds (VOC)		
Hazardous Air Pollutants	Potential Emissions	
	PPH	TPY
Regulated Pollutants other than Criteria and HAP	Potential Emissions	
	PPH	TPY

List the method(s) used to calculate the potential emissions (include dates of any stack tests conducted, versions of software used, source and dates of emission factors, etc.).

Applicable Requirements

List all applicable requirements for this emission unit. For each applicable requirement, include the underlying rule/regulation citation and/or construction permit with the condition number. (Note: Title V permit condition numbers alone are not the underlying applicable requirements). If an emission limit is calculated based on the type of source and design capacity or if a standard is based on a design parameter, this information should also be included.

From current Title V permit:

____ Permit Shield

For all applicable requirements listed above, provide monitoring/testing/recordkeeping/reporting which shall be used to demonstrate compliance. If the method is based on a permit or rule, include the condition number or citation. (Note: Each requirement listed above must have an associated method of demonstrating compliance. If there is not already a required method in place, then a method must be proposed.)

From current Title V permit:

Are you in compliance with all applicable requirements for this emission unit? Yes No

If no, complete the **Schedule of Compliance Form** as ATTACHMENT F.

ATTACHMENT E - Emission Unit Form

Emission Unit Description: <i>Storage Tank</i>			
Emission unit ID number: 200	Emission unit name: Tank 200	List any control devices associated with this emission unit: N/A	
Provide a description of the emission unit (type, method of operation, design parameters, etc.): Storage tank (retained from AA) – currently out of service.			
Manufacturer:	Model number:	Serial number:	
Construction date: See Attachment D Equipment Table	Installation date: See Attachment D Equipment Table	Modification date(s): See Attachment D Equipment Table	
Design Capacity (examples: furnaces - tons/hr, tanks - gallons): See Attachment D Equipment Table			
Maximum Hourly Throughput:	Maximum Annual Throughput:	Maximum Operating Schedule:	
Fuel Usage Data (fill out all applicable fields)			
Does this emission unit combust fuel? ___Yes ___X___ No		If yes, is it? ___ Indirect Fired ___ Direct Fired	
Maximum design heat input and/or maximum horsepower rating:		Type and Btu/hr rating of burners:	
List the primary fuel type(s) and if applicable, the secondary fuel type(s). For each fuel type listed, provide the maximum hourly and annual fuel usage for each.			
Describe each fuel expected to be used during the term of the permit.			
Fuel Type	Max. Sulfur Content	Max. Ash Content	BTU Value

<i>Emissions Data</i>		
Criteria Pollutants	Potential Emissions	
	PPH	TPY
Carbon Monoxide (CO)		
Nitrogen Oxides (NO _x)		
Lead (Pb)		
Particulate Matter (PM _{2.5})		
Particulate Matter (PM ₁₀)		
Total Particulate Matter (TSP)		
Sulfur Dioxide (SO ₂)		
Volatile Organic Compounds (VOC)		
Hazardous Air Pollutants	Potential Emissions	
	PPH	TPY
Regulated Pollutants other than Criteria and HAP	Potential Emissions	
	PPH	TPY

List the method(s) used to calculate the potential emissions (include dates of any stack tests conducted, versions of software used, source and dates of emission factors, etc.).

Applicable Requirements

List all applicable requirements for this emission unit. For each applicable requirement, include the underlying rule/regulation citation and/or construction permit with the condition number. (Note: Title V permit condition numbers alone are not the underlying applicable requirements). If an emission limit is calculated based on the type of source and design capacity or if a standard is based on a design parameter, this information should also be included.

From current Title V permit:

____ Permit Shield

For all applicable requirements listed above, provide monitoring/testing/recordkeeping/reporting which shall be used to demonstrate compliance. If the method is based on a permit or rule, include the condition number or citation. (Note: Each requirement listed above must have an associated method of demonstrating compliance. If there is not already a required method in place, then a method must be proposed.)

From current Title V permit:

Are you in compliance with all applicable requirements for this emission unit? Yes No

If no, complete the **Schedule of Compliance Form** as ATTACHMENT F.

ATTACHMENT E - Emission Unit Form

Emission Unit Description: *Storage Tank*

Emission unit ID number: 5694	Emission unit name: Tank 5694	List any control devices associated with this emission unit: N/A
---	---	--

Provide a description of the emission unit (type, method of operation, design parameters, etc.):
Storage tank (retained from AA) – currently out of service.

Manufacturer:	Model number:	Serial number:
----------------------	----------------------	-----------------------

Construction date: See Attachment D Equipment Table	Installation date: See Attachment D Equipment Table	Modification date(s): See Attachment D Equipment Table
---	---	--

Design Capacity (examples: furnaces - tons/hr, tanks - gallons): See Attachment D Equipment Table

Maximum Hourly Throughput:	Maximum Annual Throughput:	Maximum Operating Schedule: 24 hrs/day, 365 days/yr
-----------------------------------	-----------------------------------	---

Fuel Usage Data (fill out all applicable fields)

Does this emission unit combust fuel? <input type="checkbox"/> Yes <input checked="" type="checkbox"/> No	If yes, is it? <input type="checkbox"/> Indirect Fired <input type="checkbox"/> Direct Fired
--	--

Maximum design heat input and/or maximum horsepower rating:	Type and Btu/hr rating of burners:
--	---

List the primary fuel type(s) and if applicable, the secondary fuel type(s). For each fuel type listed, provide the maximum hourly and annual fuel usage for each.

Describe each fuel expected to be used during the term of the permit.

Fuel Type	Max. Sulfur Content	Max. Ash Content	BTU Value

<i>Emissions Data</i>		
Criteria Pollutants	Potential Emissions	
	PPH	TPY
Carbon Monoxide (CO)		
Nitrogen Oxides (NO _x)		
Lead (Pb)		
Particulate Matter (PM _{2.5})		
Particulate Matter (PM ₁₀)		
Total Particulate Matter (TSP)		
Sulfur Dioxide (SO ₂)		
Volatile Organic Compounds (VOC)		
Hazardous Air Pollutants	Potential Emissions	
	PPH	TPY
Regulated Pollutants other than Criteria and HAP	Potential Emissions	
	PPH	TPY

List the method(s) used to calculate the potential emissions (include dates of any stack tests conducted, versions of software used, source and dates of emission factors, etc.).

Applicable Requirements

List all applicable requirements for this emission unit. For each applicable requirement, include the underlying rule/regulation citation and/or construction permit with the condition number. (Note: Title V permit condition numbers alone are not the underlying applicable requirements). If an emission limit is calculated based on the type of source and design capacity or if a standard is based on a design parameter, this information should also be included.

From current Title V permit:

____ Permit Shield

For all applicable requirements listed above, provide monitoring/testing/recordkeeping/reporting which shall be used to demonstrate compliance. If the method is based on a permit or rule, include the condition number or citation. (Note: Each requirement listed above must have an associated method of demonstrating compliance. If there is not already a required method in place, then a method must be proposed.)

From current Title V permit:

Are you in compliance with all applicable requirements for this emission unit? Yes No

If no, complete the **Schedule of Compliance Form** as ATTACHMENT F.

ATTACHMENT E - Emission Unit Form

Emission Unit Description: *Storage Tank*

Emission unit ID number: 9120	Emission unit name: Tank 9120	List any control devices associated with this emission unit: N/A
---	---	--

Provide a description of the emission unit (type, method of operation, design parameters, etc.):
Storage tank.

Manufacturer:	Model number:	Serial number:
----------------------	----------------------	-----------------------

Construction date: See Attachment D Equipment Table	Installation date: See Attachment D Equipment Table	Modification date(s): See Attachment D Equipment Table
---	---	--

Design Capacity (examples: furnaces - tons/hr, tanks - gallons): See Attachment D Equipment Table

Maximum Hourly Throughput:	Maximum Annual Throughput:	Maximum Operating Schedule: 24 hrs/day, 365 days/yr
-----------------------------------	-----------------------------------	---

Fuel Usage Data (fill out all applicable fields)

Does this emission unit combust fuel? <input type="checkbox"/> Yes <input checked="" type="checkbox"/> No	If yes, is it? <input type="checkbox"/> Indirect Fired <input type="checkbox"/> Direct Fired
--	--

Maximum design heat input and/or maximum horsepower rating:	Type and Btu/hr rating of burners:
--	---

List the primary fuel type(s) and if applicable, the secondary fuel type(s). For each fuel type listed, provide the maximum hourly and annual fuel usage for each.

Describe each fuel expected to be used during the term of the permit.

Fuel Type	Max. Sulfur Content	Max. Ash Content	BTU Value

<i>Emissions Data</i>		
Criteria Pollutants	Potential Emissions	
	PPH	TPY
Carbon Monoxide (CO)		
Nitrogen Oxides (NO _x)		
Lead (Pb)		
Particulate Matter (PM _{2.5})		
Particulate Matter (PM ₁₀)		
Total Particulate Matter (TSP)		
Sulfur Dioxide (SO ₂)		
Volatile Organic Compounds (VOC)		
Hazardous Air Pollutants	Potential Emissions	
	PPH	TPY
Regulated Pollutants other than Criteria and HAP	Potential Emissions	
	PPH	TPY

List the method(s) used to calculate the potential emissions (include dates of any stack tests conducted, versions of software used, source and dates of emission factors, etc.).

Applicable Requirements

List all applicable requirements for this emission unit. For each applicable requirement, include the underlying rule/regulation citation and/or construction permit with the condition number. (Note: Title V permit condition numbers alone are not the underlying applicable requirements). If an emission limit is calculated based on the type of source and design capacity or if a standard is based on a design parameter, this information should also be included.

From current Title V permit:

____ Permit Shield

For all applicable requirements listed above, provide monitoring/testing/recordkeeping/reporting which shall be used to demonstrate compliance. If the method is based on a permit or rule, include the condition number or citation. (Note: Each requirement listed above must have an associated method of demonstrating compliance. If there is not already a required method in place, then a method must be proposed.)

From current Title V permit:

Are you in compliance with all applicable requirements for this emission unit? Yes No

If no, complete the **Schedule of Compliance Form** as ATTACHMENT F.

ATTACHMENT E - Emission Unit Form

Emission Unit Description: *Storage Tank*

Emission unit ID number: 9121	Emission unit name: Tank 9121	List any control devices associated with this emission unit: N/A
---	---	--

Provide a description of the emission unit (type, method of operation, design parameters, etc.):
Storage tank.

Manufacturer:	Model number:	Serial number:
----------------------	----------------------	-----------------------

Construction date: See Attachment D Equipment Table	Installation date: See Attachment D Equipment Table	Modification date(s): See Attachment D Equipment Table
---	---	--

Design Capacity (examples: furnaces - tons/hr, tanks - gallons): See Attachment D Equipment Table

Maximum Hourly Throughput:	Maximum Annual Throughput:	Maximum Operating Schedule: 24 hrs/day, 365 days/yr
-----------------------------------	-----------------------------------	---

Fuel Usage Data (fill out all applicable fields)

Does this emission unit combust fuel? <input type="checkbox"/> Yes <input checked="" type="checkbox"/> No	If yes, is it? <input type="checkbox"/> Indirect Fired <input type="checkbox"/> Direct Fired
--	--

Maximum design heat input and/or maximum horsepower rating:	Type and Btu/hr rating of burners:
--	---

List the primary fuel type(s) and if applicable, the secondary fuel type(s). For each fuel type listed, provide the maximum hourly and annual fuel usage for each.

Describe each fuel expected to be used during the term of the permit.

Fuel Type	Max. Sulfur Content	Max. Ash Content	BTU Value

<i>Emissions Data</i>		
Criteria Pollutants	Potential Emissions	
	PPH	TPY
Carbon Monoxide (CO)		
Nitrogen Oxides (NO _x)		
Lead (Pb)		
Particulate Matter (PM _{2.5})		
Particulate Matter (PM ₁₀)		
Total Particulate Matter (TSP)		
Sulfur Dioxide (SO ₂)		
Volatile Organic Compounds (VOC)		
Hazardous Air Pollutants	Potential Emissions	
	PPH	TPY
Regulated Pollutants other than Criteria and HAP	Potential Emissions	
	PPH	TPY

List the method(s) used to calculate the potential emissions (include dates of any stack tests conducted, versions of software used, source and dates of emission factors, etc.).

Applicable Requirements

List all applicable requirements for this emission unit. For each applicable requirement, include the underlying rule/regulation citation and/or construction permit with the condition number. (Note: Title V permit condition numbers alone are not the underlying applicable requirements). If an emission limit is calculated based on the type of source and design capacity or if a standard is based on a design parameter, this information should also be included.

From current Title V permit:

____ Permit Shield

For all applicable requirements listed above, provide monitoring/testing/recordkeeping/reporting which shall be used to demonstrate compliance. If the method is based on a permit or rule, include the condition number or citation. (Note: Each requirement listed above must have an associated method of demonstrating compliance. If there is not already a required method in place, then a method must be proposed.)

From current Title V permit:

Are you in compliance with all applicable requirements for this emission unit? Yes No

If no, complete the **Schedule of Compliance Form** as ATTACHMENT F.

ATTACHMENT E - Emission Unit Form

Emission Unit Description: *Storage Tank*

Emission unit ID number: 9128	Emission unit name: Tank 9128	List any control devices associated with this emission unit: N/A
---	---	--

Provide a description of the emission unit (type, method of operation, design parameters, etc.):
Storage tank.

Manufacturer:	Model number:	Serial number:
----------------------	----------------------	-----------------------

Construction date: See Attachment D Equipment Table	Installation date: See Attachment D Equipment Table	Modification date(s): See Attachment D Equipment Table
---	---	--

Design Capacity (examples: furnaces - tons/hr, tanks - gallons): See Attachment D Equipment Table

Maximum Hourly Throughput:	Maximum Annual Throughput:	Maximum Operating Schedule: 24 hrs/day, 365 days/yr
-----------------------------------	-----------------------------------	---

Fuel Usage Data (fill out all applicable fields)

Does this emission unit combust fuel? ___Yes ___X___ No	If yes, is it? ___ Indirect Fired ___ Direct Fired
--	--

Maximum design heat input and/or maximum horsepower rating:	Type and Btu/hr rating of burners:
--	---

List the primary fuel type(s) and if applicable, the secondary fuel type(s). For each fuel type listed, provide the maximum hourly and annual fuel usage for each.

Describe each fuel expected to be used during the term of the permit.

Fuel Type	Max. Sulfur Content	Max. Ash Content	BTU Value

<i>Emissions Data</i>		
Criteria Pollutants	Potential Emissions	
	PPH	TPY
Carbon Monoxide (CO)		
Nitrogen Oxides (NO _x)		
Lead (Pb)		
Particulate Matter (PM _{2.5})		
Particulate Matter (PM ₁₀)		
Total Particulate Matter (TSP)		
Sulfur Dioxide (SO ₂)		
Volatile Organic Compounds (VOC)		
Hazardous Air Pollutants	Potential Emissions	
	PPH	TPY
Regulated Pollutants other than Criteria and HAP	Potential Emissions	
	PPH	TPY

List the method(s) used to calculate the potential emissions (include dates of any stack tests conducted, versions of software used, source and dates of emission factors, etc.).

Applicable Requirements

List all applicable requirements for this emission unit. For each applicable requirement, include the underlying rule/regulation citation and/or construction permit with the condition number. (Note: Title V permit condition numbers alone are not the underlying applicable requirements). If an emission limit is calculated based on the type of source and design capacity or if a standard is based on a design parameter, this information should also be included.

From current Title V permit:

____ Permit Shield

For all applicable requirements listed above, provide monitoring/testing/recordkeeping/reporting which shall be used to demonstrate compliance. If the method is based on a permit or rule, include the condition number or citation. (Note: Each requirement listed above must have an associated method of demonstrating compliance. If there is not already a required method in place, then a method must be proposed.)

From current Title V permit:

Are you in compliance with all applicable requirements for this emission unit? Yes No

If no, complete the **Schedule of Compliance Form** as ATTACHMENT F.

ATTACHMENT E - Emission Unit Form

Emission Unit Description: *Storage Tank*

Emission unit ID number: 9129	Emission unit name: Tank 9129	List any control devices associated with this emission unit: N/A
---	---	--

Provide a description of the emission unit (type, method of operation, design parameters, etc.):
Storage tank.

Manufacturer:	Model number:	Serial number:
----------------------	----------------------	-----------------------

Construction date: See Attachment D Equipment Table	Installation date: See Attachment D Equipment Table	Modification date(s): See Attachment D Equipment Table
---	---	--

Design Capacity (examples: furnaces - tons/hr, tanks - gallons): See Attachment D Equipment Table

Maximum Hourly Throughput:	Maximum Annual Throughput:	Maximum Operating Schedule: 24 hrs/day, 365 days/yr
-----------------------------------	-----------------------------------	---

Fuel Usage Data (fill out all applicable fields)

Does this emission unit combust fuel? <input type="checkbox"/> Yes <input checked="" type="checkbox"/> No	If yes, is it? <input type="checkbox"/> Indirect Fired <input type="checkbox"/> Direct Fired
--	--

Maximum design heat input and/or maximum horsepower rating:	Type and Btu/hr rating of burners:
--	---

List the primary fuel type(s) and if applicable, the secondary fuel type(s). For each fuel type listed, provide the maximum hourly and annual fuel usage for each.

Describe each fuel expected to be used during the term of the permit.

Fuel Type	Max. Sulfur Content	Max. Ash Content	BTU Value

<i>Emissions Data</i>		
Criteria Pollutants	Potential Emissions	
	PPH	TPY
Carbon Monoxide (CO)		
Nitrogen Oxides (NO _x)		
Lead (Pb)		
Particulate Matter (PM _{2.5})		
Particulate Matter (PM ₁₀)		
Total Particulate Matter (TSP)		
Sulfur Dioxide (SO ₂)		
Volatile Organic Compounds (VOC)		
Hazardous Air Pollutants	Potential Emissions	
	PPH	TPY
Regulated Pollutants other than Criteria and HAP	Potential Emissions	
	PPH	TPY

List the method(s) used to calculate the potential emissions (include dates of any stack tests conducted, versions of software used, source and dates of emission factors, etc.).

Applicable Requirements

List all applicable requirements for this emission unit. For each applicable requirement, include the underlying rule/regulation citation and/or construction permit with the condition number. (Note: Title V permit condition numbers alone are not the underlying applicable requirements). If an emission limit is calculated based on the type of source and design capacity or if a standard is based on a design parameter, this information should also be included.

From current Title V permit:

____ Permit Shield

For all applicable requirements listed above, provide monitoring/testing/recordkeeping/reporting which shall be used to demonstrate compliance. If the method is based on a permit or rule, include the condition number or citation. (Note: Each requirement listed above must have an associated method of demonstrating compliance. If there is not already a required method in place, then a method must be proposed.)

From current Title V permit:

Are you in compliance with all applicable requirements for this emission unit? Yes No

If no, complete the **Schedule of Compliance Form** as ATTACHMENT F.

ATTACHMENT E - Emission Unit Form

Emission Unit Description: *Storage Tank*

Emission unit ID number: 9151	Emission unit name: Tank 9151	List any control devices associated with this emission unit: N/A
---	---	--

Provide a description of the emission unit (type, method of operation, design parameters, etc.):
Storage tank.

Manufacturer:	Model number:	Serial number:
----------------------	----------------------	-----------------------

Construction date: See Attachment D Equipment Table	Installation date: See Attachment D Equipment Table	Modification date(s): See Attachment D Equipment Table
---	---	--

Design Capacity (examples: furnaces - tons/hr, tanks - gallons): See Attachment D Equipment Table

Maximum Hourly Throughput:	Maximum Annual Throughput:	Maximum Operating Schedule: 24 hrs/day, 365 days/yr
-----------------------------------	-----------------------------------	---

Fuel Usage Data (fill out all applicable fields)

Does this emission unit combust fuel? <input type="checkbox"/> Yes <input checked="" type="checkbox"/> No	If yes, is it? <input type="checkbox"/> Indirect Fired <input type="checkbox"/> Direct Fired
--	--

Maximum design heat input and/or maximum horsepower rating:	Type and Btu/hr rating of burners:
--	---

List the primary fuel type(s) and if applicable, the secondary fuel type(s). For each fuel type listed, provide the maximum hourly and annual fuel usage for each.

Describe each fuel expected to be used during the term of the permit.

Fuel Type	Max. Sulfur Content	Max. Ash Content	BTU Value

<i>Emissions Data</i>		
Criteria Pollutants	Potential Emissions	
	PPH	TPY
Carbon Monoxide (CO)		
Nitrogen Oxides (NO _x)		
Lead (Pb)		
Particulate Matter (PM _{2.5})		
Particulate Matter (PM ₁₀)		
Total Particulate Matter (TSP)		
Sulfur Dioxide (SO ₂)		
Volatile Organic Compounds (VOC)		
Hazardous Air Pollutants	Potential Emissions	
	PPH	TPY
Regulated Pollutants other than Criteria and HAP	Potential Emissions	
	PPH	TPY

List the method(s) used to calculate the potential emissions (include dates of any stack tests conducted, versions of software used, source and dates of emission factors, etc.).

Applicable Requirements

List all applicable requirements for this emission unit. For each applicable requirement, include the underlying rule/regulation citation and/or construction permit with the condition number. (Note: Title V permit condition numbers alone are not the underlying applicable requirements). If an emission limit is calculated based on the type of source and design capacity or if a standard is based on a design parameter, this information should also be included.

From current Title V permit:

____ Permit Shield

For all applicable requirements listed above, provide monitoring/testing/recordkeeping/reporting which shall be used to demonstrate compliance. If the method is based on a permit or rule, include the condition number or citation. (Note: Each requirement listed above must have an associated method of demonstrating compliance. If there is not already a required method in place, then a method must be proposed.)

From current Title V permit:

Are you in compliance with all applicable requirements for this emission unit? Yes No

If no, complete the **Schedule of Compliance Form** as ATTACHMENT F.

ATTACHMENT E - Emission Unit Form

Emission Unit Description: *Storage Tank*

Emission unit ID number: 9180	Emission unit name: Tank 9180	List any control devices associated with this emission unit: N/A
---	---	--

Provide a description of the emission unit (type, method of operation, design parameters, etc.):
Storage tank.

Manufacturer:	Model number:	Serial number:
----------------------	----------------------	-----------------------

Construction date: See Attachment D Equipment Table	Installation date: See Attachment D Equipment Table	Modification date(s): See Attachment D Equipment Table
---	---	--

Design Capacity (examples: furnaces - tons/hr, tanks - gallons): See Attachment D Equipment Table

Maximum Hourly Throughput:	Maximum Annual Throughput:	Maximum Operating Schedule: 24 hrs/day, 365 days/yr
-----------------------------------	-----------------------------------	---

Fuel Usage Data (fill out all applicable fields)

Does this emission unit combust fuel? <input type="checkbox"/> Yes <input checked="" type="checkbox"/> No	If yes, is it? <input type="checkbox"/> Indirect Fired <input type="checkbox"/> Direct Fired
--	--

Maximum design heat input and/or maximum horsepower rating:	Type and Btu/hr rating of burners:
--	---

List the primary fuel type(s) and if applicable, the secondary fuel type(s). For each fuel type listed, provide the maximum hourly and annual fuel usage for each.

Describe each fuel expected to be used during the term of the permit.

Fuel Type	Max. Sulfur Content	Max. Ash Content	BTU Value

<i>Emissions Data</i>		
Criteria Pollutants	Potential Emissions	
	PPH	TPY
Carbon Monoxide (CO)		
Nitrogen Oxides (NO _x)		
Lead (Pb)		
Particulate Matter (PM _{2.5})		
Particulate Matter (PM ₁₀)		
Total Particulate Matter (TSP)		
Sulfur Dioxide (SO ₂)		
Volatile Organic Compounds (VOC)		
Hazardous Air Pollutants	Potential Emissions	
	PPH	TPY
Regulated Pollutants other than Criteria and HAP	Potential Emissions	
	PPH	TPY

List the method(s) used to calculate the potential emissions (include dates of any stack tests conducted, versions of software used, source and dates of emission factors, etc.).

Applicable Requirements

List all applicable requirements for this emission unit. For each applicable requirement, include the underlying rule/regulation citation and/or construction permit with the condition number. (Note: Title V permit condition numbers alone are not the underlying applicable requirements). If an emission limit is calculated based on the type of source and design capacity or if a standard is based on a design parameter, this information should also be included.

From current Title V permit:

____ Permit Shield

For all applicable requirements listed above, provide monitoring/testing/recordkeeping/reporting which shall be used to demonstrate compliance. If the method is based on a permit or rule, include the condition number or citation. (Note: Each requirement listed above must have an associated method of demonstrating compliance. If there is not already a required method in place, then a method must be proposed.)

From current Title V permit:

Are you in compliance with all applicable requirements for this emission unit? Yes No

If no, complete the **Schedule of Compliance Form** as ATTACHMENT F.

ATTACHMENT E - Emission Unit Form

Emission Unit Description: *Storage Tank*

Emission unit ID number: 9181	Emission unit name: Tank 9181	List any control devices associated with this emission unit: N/A
---	---	--

Provide a description of the emission unit (type, method of operation, design parameters, etc.):
Storage tank.

Manufacturer:	Model number:	Serial number:
----------------------	----------------------	-----------------------

Construction date: See Attachment D Equipment Table	Installation date: See Attachment D Equipment Table	Modification date(s): See Attachment D Equipment Table
---	---	--

Design Capacity (examples: furnaces - tons/hr, tanks - gallons): See Attachment D Equipment Table

Maximum Hourly Throughput:	Maximum Annual Throughput:	Maximum Operating Schedule: 24 hrs/day, 365 days/yr
-----------------------------------	-----------------------------------	---

Fuel Usage Data (fill out all applicable fields)

Does this emission unit combust fuel? <input type="checkbox"/> Yes <input checked="" type="checkbox"/> No	If yes, is it? <input type="checkbox"/> Indirect Fired <input type="checkbox"/> Direct Fired
--	--

Maximum design heat input and/or maximum horsepower rating:	Type and Btu/hr rating of burners:
--	---

List the primary fuel type(s) and if applicable, the secondary fuel type(s). For each fuel type listed, provide the maximum hourly and annual fuel usage for each.

Describe each fuel expected to be used during the term of the permit.

Fuel Type	Max. Sulfur Content	Max. Ash Content	BTU Value

<i>Emissions Data</i>		
Criteria Pollutants	Potential Emissions	
	PPH	TPY
Carbon Monoxide (CO)		
Nitrogen Oxides (NO _x)		
Lead (Pb)		
Particulate Matter (PM _{2.5})		
Particulate Matter (PM ₁₀)		
Total Particulate Matter (TSP)		
Sulfur Dioxide (SO ₂)		
Volatile Organic Compounds (VOC)		
Hazardous Air Pollutants	Potential Emissions	
	PPH	TPY
Regulated Pollutants other than Criteria and HAP	Potential Emissions	
	PPH	TPY

List the method(s) used to calculate the potential emissions (include dates of any stack tests conducted, versions of software used, source and dates of emission factors, etc.).

Applicable Requirements

List all applicable requirements for this emission unit. For each applicable requirement, include the underlying rule/regulation citation and/or construction permit with the condition number. (Note: Title V permit condition numbers alone are not the underlying applicable requirements). If an emission limit is calculated based on the type of source and design capacity or if a standard is based on a design parameter, this information should also be included.

From current Title V permit:

____ Permit Shield

For all applicable requirements listed above, provide monitoring/testing/recordkeeping/reporting which shall be used to demonstrate compliance. If the method is based on a permit or rule, include the condition number or citation. (Note: Each requirement listed above must have an associated method of demonstrating compliance. If there is not already a required method in place, then a method must be proposed.)

From current Title V permit:

Are you in compliance with all applicable requirements for this emission unit? Yes No

If no, complete the **Schedule of Compliance Form** as ATTACHMENT F.

ATTACHMENT E - Emission Unit Form

Emission Unit Description: *Storage Tank*

Emission unit ID number: 9182	Emission unit name: Tank 9182	List any control devices associated with this emission unit: N/A
---	---	--

Provide a description of the emission unit (type, method of operation, design parameters, etc.):
Storage tank.

Manufacturer:	Model number:	Serial number:
----------------------	----------------------	-----------------------

Construction date: See Attachment D Equipment Table	Installation date: See Attachment D Equipment Table	Modification date(s): See Attachment D Equipment Table
---	---	--

Design Capacity (examples: furnaces - tons/hr, tanks - gallons): See Attachment D Equipment Table

Maximum Hourly Throughput:	Maximum Annual Throughput:	Maximum Operating Schedule: 24 hrs/day, 365 days/yr
-----------------------------------	-----------------------------------	---

Fuel Usage Data (fill out all applicable fields)

Does this emission unit combust fuel? ___Yes ___X___ No	If yes, is it? ___ Indirect Fired ___ Direct Fired
--	--

Maximum design heat input and/or maximum horsepower rating:	Type and Btu/hr rating of burners:
--	---

List the primary fuel type(s) and if applicable, the secondary fuel type(s). For each fuel type listed, provide the maximum hourly and annual fuel usage for each.

Describe each fuel expected to be used during the term of the permit.

Fuel Type	Max. Sulfur Content	Max. Ash Content	BTU Value

<i>Emissions Data</i>		
Criteria Pollutants	Potential Emissions	
	PPH	TPY
Carbon Monoxide (CO)		
Nitrogen Oxides (NO _x)		
Lead (Pb)		
Particulate Matter (PM _{2.5})		
Particulate Matter (PM ₁₀)		
Total Particulate Matter (TSP)		
Sulfur Dioxide (SO ₂)		
Volatile Organic Compounds (VOC)		
Hazardous Air Pollutants	Potential Emissions	
	PPH	TPY
Regulated Pollutants other than Criteria and HAP	Potential Emissions	
	PPH	TPY

List the method(s) used to calculate the potential emissions (include dates of any stack tests conducted, versions of software used, source and dates of emission factors, etc.).

Applicable Requirements

List all applicable requirements for this emission unit. For each applicable requirement, include the underlying rule/regulation citation and/or construction permit with the condition number. (Note: Title V permit condition numbers alone are not the underlying applicable requirements). If an emission limit is calculated based on the type of source and design capacity or if a standard is based on a design parameter, this information should also be included.

From current Title V permit:

____ Permit Shield

For all applicable requirements listed above, provide monitoring/testing/recordkeeping/reporting which shall be used to demonstrate compliance. If the method is based on a permit or rule, include the condition number or citation. (Note: Each requirement listed above must have an associated method of demonstrating compliance. If there is not already a required method in place, then a method must be proposed.)

From current Title V permit:

Are you in compliance with all applicable requirements for this emission unit? Yes No

If no, complete the **Schedule of Compliance Form** as ATTACHMENT F.

ATTACHMENT E - Emission Unit Form

Emission Unit Description: *Storage Tank*

Emission unit ID number: 9186	Emission unit name: Tank 9186	List any control devices associated with this emission unit: N/A
---	---	--

Provide a description of the emission unit (type, method of operation, design parameters, etc.):
Storage tank.

Manufacturer:	Model number:	Serial number:
----------------------	----------------------	-----------------------

Construction date: See Attachment D Equipment Table	Installation date: See Attachment D Equipment Table	Modification date(s): See Attachment D Equipment Table
---	---	--

Design Capacity (examples: furnaces - tons/hr, tanks - gallons): See Attachment D Equipment Table

Maximum Hourly Throughput:	Maximum Annual Throughput:	Maximum Operating Schedule: 24 hrs/day, 365 days/yr
-----------------------------------	-----------------------------------	---

Fuel Usage Data (fill out all applicable fields)

Does this emission unit combust fuel? <input type="checkbox"/> Yes <input checked="" type="checkbox"/> No	If yes, is it? <input type="checkbox"/> Indirect Fired <input type="checkbox"/> Direct Fired
--	--

Maximum design heat input and/or maximum horsepower rating:	Type and Btu/hr rating of burners:
--	---

List the primary fuel type(s) and if applicable, the secondary fuel type(s). For each fuel type listed, provide the maximum hourly and annual fuel usage for each.

Describe each fuel expected to be used during the term of the permit.

Fuel Type	Max. Sulfur Content	Max. Ash Content	BTU Value

<i>Emissions Data</i>		
Criteria Pollutants	Potential Emissions	
	PPH	TPY
Carbon Monoxide (CO)		
Nitrogen Oxides (NO _x)		
Lead (Pb)		
Particulate Matter (PM _{2.5})		
Particulate Matter (PM ₁₀)		
Total Particulate Matter (TSP)		
Sulfur Dioxide (SO ₂)		
Volatile Organic Compounds (VOC)		
Hazardous Air Pollutants	Potential Emissions	
	PPH	TPY
Regulated Pollutants other than Criteria and HAP	Potential Emissions	
	PPH	TPY
<p>List the method(s) used to calculate the potential emissions (include dates of any stack tests conducted, versions of software used, source and dates of emission factors, etc.).</p>		

Applicable Requirements

List all applicable requirements for this emission unit. For each applicable requirement, include the underlying rule/regulation citation and/or construction permit with the condition number. (Note: Title V permit condition numbers alone are not the underlying applicable requirements). If an emission limit is calculated based on the type of source and design capacity or if a standard is based on a design parameter, this information should also be included.

From current Title V permit:

____ Permit Shield

For all applicable requirements listed above, provide monitoring/testing/recordkeeping/reporting which shall be used to demonstrate compliance. If the method is based on a permit or rule, include the condition number or citation. (Note: Each requirement listed above must have an associated method of demonstrating compliance. If there is not already a required method in place, then a method must be proposed.)

From current Title V permit:

Are you in compliance with all applicable requirements for this emission unit? Yes No

If no, complete the **Schedule of Compliance Form** as ATTACHMENT F.

ATTACHMENT E - Emission Unit Form

Emission Unit Description: *Storage Tank*

Emission unit ID number: 9187	Emission unit name: Tank 9187	List any control devices associated with this emission unit: N/A
---	---	--

Provide a description of the emission unit (type, method of operation, design parameters, etc.):
Storage tank.

Manufacturer:	Model number:	Serial number:
----------------------	----------------------	-----------------------

Construction date: See Attachment D Equipment Table	Installation date: See Attachment D Equipment Table	Modification date(s): See Attachment D Equipment Table
---	---	--

Design Capacity (examples: furnaces - tons/hr, tanks - gallons): See Attachment D Equipment Table

Maximum Hourly Throughput:	Maximum Annual Throughput:	Maximum Operating Schedule: 24 hrs/day, 365 days/yr
-----------------------------------	-----------------------------------	---

Fuel Usage Data (fill out all applicable fields)

Does this emission unit combust fuel? <input type="checkbox"/> Yes <input checked="" type="checkbox"/> No	If yes, is it? <input type="checkbox"/> Indirect Fired <input type="checkbox"/> Direct Fired
--	--

Maximum design heat input and/or maximum horsepower rating:	Type and Btu/hr rating of burners:
--	---

List the primary fuel type(s) and if applicable, the secondary fuel type(s). For each fuel type listed, provide the maximum hourly and annual fuel usage for each.

Describe each fuel expected to be used during the term of the permit.

Fuel Type	Max. Sulfur Content	Max. Ash Content	BTU Value

<i>Emissions Data</i>		
Criteria Pollutants	Potential Emissions	
	PPH	TPY
Carbon Monoxide (CO)		
Nitrogen Oxides (NO _x)		
Lead (Pb)		
Particulate Matter (PM _{2.5})		
Particulate Matter (PM ₁₀)		
Total Particulate Matter (TSP)		
Sulfur Dioxide (SO ₂)		
Volatile Organic Compounds (VOC)		
Hazardous Air Pollutants	Potential Emissions	
	PPH	TPY
Regulated Pollutants other than Criteria and HAP	Potential Emissions	
	PPH	TPY

List the method(s) used to calculate the potential emissions (include dates of any stack tests conducted, versions of software used, source and dates of emission factors, etc.).

Applicable Requirements

List all applicable requirements for this emission unit. For each applicable requirement, include the underlying rule/regulation citation and/or construction permit with the condition number. (Note: Title V permit condition numbers alone are not the underlying applicable requirements). If an emission limit is calculated based on the type of source and design capacity or if a standard is based on a design parameter, this information should also be included.

From current Title V permit:

____ Permit Shield

For all applicable requirements listed above, provide monitoring/testing/recordkeeping/reporting which shall be used to demonstrate compliance. If the method is based on a permit or rule, include the condition number or citation. (Note: Each requirement listed above must have an associated method of demonstrating compliance. If there is not already a required method in place, then a method must be proposed.)

From current Title V permit:

Are you in compliance with all applicable requirements for this emission unit? Yes No

If no, complete the **Schedule of Compliance Form** as ATTACHMENT F.

ATTACHMENT E - Emission Unit Form

Emission Unit Description: <i>Storage Tank</i>			
Emission unit ID number: 9223	Emission unit name: Tank 9223	List any control devices associated with this emission unit: N/A	
Provide a description of the emission unit (type, method of operation, design parameters, etc.): Storage tank.			
Manufacturer:	Model number:	Serial number:	
Construction date: See Attachment D Equipment Table	Installation date: See Attachment D Equipment Table	Modification date(s): See Attachment D Equipment Table	
Design Capacity (examples: furnaces - tons/hr, tanks - gallons): See Attachment D Equipment Table			
Maximum Hourly Throughput:	Maximum Annual Throughput:	Maximum Operating Schedule: 24 hrs/day, 365 days/yr	
Fuel Usage Data (fill out all applicable fields)			
Does this emission unit combust fuel? ___Yes ___X___ No		If yes, is it? ___ Indirect Fired ___ Direct Fired	
Maximum design heat input and/or maximum horsepower rating:		Type and Btu/hr rating of burners:	
List the primary fuel type(s) and if applicable, the secondary fuel type(s). For each fuel type listed, provide the maximum hourly and annual fuel usage for each.			
Describe each fuel expected to be used during the term of the permit.			
Fuel Type	Max. Sulfur Content	Max. Ash Content	BTU Value

<i>Emissions Data</i>		
Criteria Pollutants	Potential Emissions	
	PPH	TPY
Carbon Monoxide (CO)		
Nitrogen Oxides (NO _x)		
Lead (Pb)		
Particulate Matter (PM _{2.5})		
Particulate Matter (PM ₁₀)		
Total Particulate Matter (TSP)		
Sulfur Dioxide (SO ₂)		
Volatile Organic Compounds (VOC)		
Hazardous Air Pollutants	Potential Emissions	
	PPH	TPY
Regulated Pollutants other than Criteria and HAP	Potential Emissions	
	PPH	TPY

List the method(s) used to calculate the potential emissions (include dates of any stack tests conducted, versions of software used, source and dates of emission factors, etc.).

Applicable Requirements

List all applicable requirements for this emission unit. For each applicable requirement, include the underlying rule/regulation citation and/or construction permit with the condition number. (Note: Title V permit condition numbers alone are not the underlying applicable requirements). If an emission limit is calculated based on the type of source and design capacity or if a standard is based on a design parameter, this information should also be included.

From current Title V permit:

____ Permit Shield

For all applicable requirements listed above, provide monitoring/testing/recordkeeping/reporting which shall be used to demonstrate compliance. If the method is based on a permit or rule, include the condition number or citation. (Note: Each requirement listed above must have an associated method of demonstrating compliance. If there is not already a required method in place, then a method must be proposed.)

From current Title V permit:

Are you in compliance with all applicable requirements for this emission unit? Yes No

If no, complete the **Schedule of Compliance Form** as ATTACHMENT F.

ATTACHMENT E - Emission Unit Form

Emission Unit Description: *Storage Tank*

Emission unit ID number: 9228	Emission unit name: Tank 9228	List any control devices associated with this emission unit: N/A
---	---	--

Provide a description of the emission unit (type, method of operation, design parameters, etc.):
Storage tank.

Manufacturer:	Model number:	Serial number:
----------------------	----------------------	-----------------------

Construction date: See Attachment D Equipment Table	Installation date: See Attachment D Equipment Table	Modification date(s): See Attachment D Equipment Table
---	---	--

Design Capacity (examples: furnaces - tons/hr, tanks - gallons): See Attachment D Equipment Table

Maximum Hourly Throughput:	Maximum Annual Throughput:	Maximum Operating Schedule: 24 hrs/day, 365 days/yr
-----------------------------------	-----------------------------------	---

Fuel Usage Data (fill out all applicable fields)

Does this emission unit combust fuel? ___Yes ___X___ No	If yes, is it? ___ Indirect Fired ___ Direct Fired
--	--

Maximum design heat input and/or maximum horsepower rating:	Type and Btu/hr rating of burners:
--	---

List the primary fuel type(s) and if applicable, the secondary fuel type(s). For each fuel type listed, provide the maximum hourly and annual fuel usage for each.

Describe each fuel expected to be used during the term of the permit.

Fuel Type	Max. Sulfur Content	Max. Ash Content	BTU Value

<i>Emissions Data</i>		
Criteria Pollutants	Potential Emissions	
	PPH	TPY
Carbon Monoxide (CO)		
Nitrogen Oxides (NO _x)		
Lead (Pb)		
Particulate Matter (PM _{2.5})		
Particulate Matter (PM ₁₀)		
Total Particulate Matter (TSP)		
Sulfur Dioxide (SO ₂)		
Volatile Organic Compounds (VOC)		
Hazardous Air Pollutants	Potential Emissions	
	PPH	TPY
Regulated Pollutants other than Criteria and HAP	Potential Emissions	
	PPH	TPY

List the method(s) used to calculate the potential emissions (include dates of any stack tests conducted, versions of software used, source and dates of emission factors, etc.).

Applicable Requirements

List all applicable requirements for this emission unit. For each applicable requirement, include the underlying rule/regulation citation and/or construction permit with the condition number. (Note: Title V permit condition numbers alone are not the underlying applicable requirements). If an emission limit is calculated based on the type of source and design capacity or if a standard is based on a design parameter, this information should also be included.

From current Title V permit:

____ Permit Shield

For all applicable requirements listed above, provide monitoring/testing/recordkeeping/reporting which shall be used to demonstrate compliance. If the method is based on a permit or rule, include the condition number or citation. (Note: Each requirement listed above must have an associated method of demonstrating compliance. If there is not already a required method in place, then a method must be proposed.)

From current Title V permit:

Are you in compliance with all applicable requirements for this emission unit? Yes No

If no, complete the **Schedule of Compliance Form** as ATTACHMENT F.

ATTACHMENT E - Emission Unit Form

Emission Unit Description: *Storage Tank*

Emission unit ID number: 9501	Emission unit name: Tank 9501	List any control devices associated with this emission unit: N/A
---	---	--

Provide a description of the emission unit (type, method of operation, design parameters, etc.):
Storage tank.

Manufacturer:	Model number:	Serial number:
----------------------	----------------------	-----------------------

Construction date: See Attachment D Equipment Table	Installation date: See Attachment D Equipment Table	Modification date(s): See Attachment D Equipment Table
---	---	--

Design Capacity (examples: furnaces - tons/hr, tanks - gallons): See Attachment D Equipment Table

Maximum Hourly Throughput:	Maximum Annual Throughput:	Maximum Operating Schedule: 24 hrs/day, 365 days/yr
-----------------------------------	-----------------------------------	---

Fuel Usage Data (fill out all applicable fields)

Does this emission unit combust fuel? ___Yes ___X___ No	If yes, is it? ___ Indirect Fired ___ Direct Fired
--	--

Maximum design heat input and/or maximum horsepower rating:	Type and Btu/hr rating of burners:
--	---

List the primary fuel type(s) and if applicable, the secondary fuel type(s). For each fuel type listed, provide the maximum hourly and annual fuel usage for each.

Describe each fuel expected to be used during the term of the permit.

Fuel Type	Max. Sulfur Content	Max. Ash Content	BTU Value

<i>Emissions Data</i>		
Criteria Pollutants	Potential Emissions	
	PPH	TPY
Carbon Monoxide (CO)		
Nitrogen Oxides (NO _x)		
Lead (Pb)		
Particulate Matter (PM _{2.5})		
Particulate Matter (PM ₁₀)		
Total Particulate Matter (TSP)		
Sulfur Dioxide (SO ₂)		
Volatile Organic Compounds (VOC)		
Hazardous Air Pollutants	Potential Emissions	
	PPH	TPY
Regulated Pollutants other than Criteria and HAP	Potential Emissions	
	PPH	TPY

List the method(s) used to calculate the potential emissions (include dates of any stack tests conducted, versions of software used, source and dates of emission factors, etc.).

Applicable Requirements

List all applicable requirements for this emission unit. For each applicable requirement, include the underlying rule/regulation citation and/or construction permit with the condition number. (Note: Title V permit condition numbers alone are not the underlying applicable requirements). If an emission limit is calculated based on the type of source and design capacity or if a standard is based on a design parameter, this information should also be included.

From current Title V permit:

____ Permit Shield

For all applicable requirements listed above, provide monitoring/testing/recordkeeping/reporting which shall be used to demonstrate compliance. If the method is based on a permit or rule, include the condition number or citation. (Note: Each requirement listed above must have an associated method of demonstrating compliance. If there is not already a required method in place, then a method must be proposed.)

From current Title V permit:

Are you in compliance with all applicable requirements for this emission unit? Yes No

If no, complete the **Schedule of Compliance Form** as ATTACHMENT F.

ATTACHMENT E - Emission Unit Form

Emission Unit Description: *Storage Tank*

Emission unit ID number: 9502	Emission unit name: Tank 9502	List any control devices associated with this emission unit: N/A
---	---	--

Provide a description of the emission unit (type, method of operation, design parameters, etc.):
Storage tank.

Manufacturer:	Model number:	Serial number:
----------------------	----------------------	-----------------------

Construction date: See Attachment D Equipment Table	Installation date: See Attachment D Equipment Table	Modification date(s): See Attachment D Equipment Table
---	---	--

Design Capacity (examples: furnaces - tons/hr, tanks - gallons): See Attachment D Equipment Table

Maximum Hourly Throughput:	Maximum Annual Throughput:	Maximum Operating Schedule: 24 hrs/day, 365 days/yr
-----------------------------------	-----------------------------------	---

Fuel Usage Data (fill out all applicable fields)

Does this emission unit combust fuel? ___Yes ___X___ No	If yes, is it? ___ Indirect Fired ___ Direct Fired
--	--

Maximum design heat input and/or maximum horsepower rating:	Type and Btu/hr rating of burners:
--	---

List the primary fuel type(s) and if applicable, the secondary fuel type(s). For each fuel type listed, provide the maximum hourly and annual fuel usage for each.

Describe each fuel expected to be used during the term of the permit.

Fuel Type	Max. Sulfur Content	Max. Ash Content	BTU Value

<i>Emissions Data</i>		
Criteria Pollutants	Potential Emissions	
	PPH	TPY
Carbon Monoxide (CO)		
Nitrogen Oxides (NO _x)		
Lead (Pb)		
Particulate Matter (PM _{2.5})		
Particulate Matter (PM ₁₀)		
Total Particulate Matter (TSP)		
Sulfur Dioxide (SO ₂)		
Volatile Organic Compounds (VOC)		
Hazardous Air Pollutants	Potential Emissions	
	PPH	TPY
Regulated Pollutants other than Criteria and HAP	Potential Emissions	
	PPH	TPY

List the method(s) used to calculate the potential emissions (include dates of any stack tests conducted, versions of software used, source and dates of emission factors, etc.).

Applicable Requirements

List all applicable requirements for this emission unit. For each applicable requirement, include the underlying rule/regulation citation and/or construction permit with the condition number. (Note: Title V permit condition numbers alone are not the underlying applicable requirements). If an emission limit is calculated based on the type of source and design capacity or if a standard is based on a design parameter, this information should also be included.

From current Title V permit:

____ Permit Shield

For all applicable requirements listed above, provide monitoring/testing/recordkeeping/reporting which shall be used to demonstrate compliance. If the method is based on a permit or rule, include the condition number or citation. (Note: Each requirement listed above must have an associated method of demonstrating compliance. If there is not already a required method in place, then a method must be proposed.)

From current Title V permit:

Are you in compliance with all applicable requirements for this emission unit? Yes No

If no, complete the **Schedule of Compliance Form** as ATTACHMENT F.

ATTACHMENT E - Emission Unit Form

Emission Unit Description: *Storage Tank*

Emission unit ID number: 9504	Emission unit name: Tank 9504	List any control devices associated with this emission unit: N/A
---	---	--

Provide a description of the emission unit (type, method of operation, design parameters, etc.):
Storage tank.

Manufacturer:	Model number:	Serial number:
----------------------	----------------------	-----------------------

Construction date: See Attachment D Equipment Table	Installation date: See Attachment D Equipment Table	Modification date(s): See Attachment D Equipment Table
---	---	--

Design Capacity (examples: furnaces - tons/hr, tanks - gallons): See Attachment D Equipment Table

Maximum Hourly Throughput:	Maximum Annual Throughput:	Maximum Operating Schedule: 24 hrs/day, 365 days/yr
-----------------------------------	-----------------------------------	---

Fuel Usage Data (fill out all applicable fields)

Does this emission unit combust fuel? ___Yes ___X___ No	If yes, is it? ___ Indirect Fired ___ Direct Fired
--	--

Maximum design heat input and/or maximum horsepower rating:	Type and Btu/hr rating of burners:
--	---

List the primary fuel type(s) and if applicable, the secondary fuel type(s). For each fuel type listed, provide the maximum hourly and annual fuel usage for each.

Describe each fuel expected to be used during the term of the permit.

Fuel Type	Max. Sulfur Content	Max. Ash Content	BTU Value

<i>Emissions Data</i>		
Criteria Pollutants	Potential Emissions	
	PPH	TPY
Carbon Monoxide (CO)		
Nitrogen Oxides (NO _x)		
Lead (Pb)		
Particulate Matter (PM _{2.5})		
Particulate Matter (PM ₁₀)		
Total Particulate Matter (TSP)		
Sulfur Dioxide (SO ₂)		
Volatile Organic Compounds (VOC)		
Hazardous Air Pollutants	Potential Emissions	
	PPH	TPY
Regulated Pollutants other than Criteria and HAP	Potential Emissions	
	PPH	TPY

List the method(s) used to calculate the potential emissions (include dates of any stack tests conducted, versions of software used, source and dates of emission factors, etc.).

Applicable Requirements

List all applicable requirements for this emission unit. For each applicable requirement, include the underlying rule/regulation citation and/or construction permit with the condition number. (Note: Title V permit condition numbers alone are not the underlying applicable requirements). If an emission limit is calculated based on the type of source and design capacity or if a standard is based on a design parameter, this information should also be included.

From current Title V permit:

____ Permit Shield

For all applicable requirements listed above, provide monitoring/testing/recordkeeping/reporting which shall be used to demonstrate compliance. If the method is based on a permit or rule, include the condition number or citation. (Note: Each requirement listed above must have an associated method of demonstrating compliance. If there is not already a required method in place, then a method must be proposed.)

From current Title V permit:

Are you in compliance with all applicable requirements for this emission unit? Yes No

If no, complete the **Schedule of Compliance Form** as ATTACHMENT F.

ATTACHMENT E - Emission Unit Form

Emission Unit Description: *Storage Tank*

Emission unit ID number: 9505	Emission unit name: Tank 9505	List any control devices associated with this emission unit: N/A
---	---	--

Provide a description of the emission unit (type, method of operation, design parameters, etc.):
Storage tank.

Manufacturer:	Model number:	Serial number:
----------------------	----------------------	-----------------------

Construction date: See Attachment D Equipment Table	Installation date: See Attachment D Equipment Table	Modification date(s): See Attachment D Equipment Table
---	---	--

Design Capacity (examples: furnaces - tons/hr, tanks - gallons): See Attachment D Equipment Table

Maximum Hourly Throughput:	Maximum Annual Throughput:	Maximum Operating Schedule: 24 hrs/day, 365 days/yr
-----------------------------------	-----------------------------------	---

Fuel Usage Data (fill out all applicable fields)

Does this emission unit combust fuel? <input type="checkbox"/> Yes <input checked="" type="checkbox"/> No	If yes, is it? <input type="checkbox"/> Indirect Fired <input type="checkbox"/> Direct Fired
--	--

Maximum design heat input and/or maximum horsepower rating:	Type and Btu/hr rating of burners:
--	---

List the primary fuel type(s) and if applicable, the secondary fuel type(s). For each fuel type listed, provide the maximum hourly and annual fuel usage for each.

Describe each fuel expected to be used during the term of the permit.

Fuel Type	Max. Sulfur Content	Max. Ash Content	BTU Value

<i>Emissions Data</i>		
Criteria Pollutants	Potential Emissions	
	PPH	TPY
Carbon Monoxide (CO)		
Nitrogen Oxides (NO _x)		
Lead (Pb)		
Particulate Matter (PM _{2.5})		
Particulate Matter (PM ₁₀)		
Total Particulate Matter (TSP)		
Sulfur Dioxide (SO ₂)		
Volatile Organic Compounds (VOC)		
Hazardous Air Pollutants	Potential Emissions	
	PPH	TPY
Regulated Pollutants other than Criteria and HAP	Potential Emissions	
	PPH	TPY

List the method(s) used to calculate the potential emissions (include dates of any stack tests conducted, versions of software used, source and dates of emission factors, etc.).

Applicable Requirements

List all applicable requirements for this emission unit. For each applicable requirement, include the underlying rule/regulation citation and/or construction permit with the condition number. (Note: Title V permit condition numbers alone are not the underlying applicable requirements). If an emission limit is calculated based on the type of source and design capacity or if a standard is based on a design parameter, this information should also be included.

From current Title V permit:

____ Permit Shield

For all applicable requirements listed above, provide monitoring/testing/recordkeeping/reporting which shall be used to demonstrate compliance. If the method is based on a permit or rule, include the condition number or citation. (Note: Each requirement listed above must have an associated method of demonstrating compliance. If there is not already a required method in place, then a method must be proposed.)

From current Title V permit:

Are you in compliance with all applicable requirements for this emission unit? Yes No

If no, complete the **Schedule of Compliance Form** as ATTACHMENT F.

ATTACHMENT E - Emission Unit Form

Emission Unit Description: *Storage Tank*

Emission unit ID number: 9507	Emission unit name: Tank 9507	List any control devices associated with this emission unit: N/A
---	---	--

Provide a description of the emission unit (type, method of operation, design parameters, etc.):
Storage tank.

Manufacturer:	Model number:	Serial number:
----------------------	----------------------	-----------------------

Construction date: See Attachment D Equipment Table	Installation date: See Attachment D Equipment Table	Modification date(s): See Attachment D Equipment Table
---	---	--

Design Capacity (examples: furnaces - tons/hr, tanks - gallons): See Attachment D Equipment Table

Maximum Hourly Throughput:	Maximum Annual Throughput:	Maximum Operating Schedule: 24 hrs/day, 365 days/yr
-----------------------------------	-----------------------------------	---

Fuel Usage Data (fill out all applicable fields)

Does this emission unit combust fuel? ___Yes ___X___ No	If yes, is it? ___ Indirect Fired ___ Direct Fired
--	--

Maximum design heat input and/or maximum horsepower rating:	Type and Btu/hr rating of burners:
--	---

List the primary fuel type(s) and if applicable, the secondary fuel type(s). For each fuel type listed, provide the maximum hourly and annual fuel usage for each.

Describe each fuel expected to be used during the term of the permit.

Fuel Type	Max. Sulfur Content	Max. Ash Content	BTU Value

<i>Emissions Data</i>		
Criteria Pollutants	Potential Emissions	
	PPH	TPY
Carbon Monoxide (CO)		
Nitrogen Oxides (NO _x)		
Lead (Pb)		
Particulate Matter (PM _{2.5})		
Particulate Matter (PM ₁₀)		
Total Particulate Matter (TSP)		
Sulfur Dioxide (SO ₂)		
Volatile Organic Compounds (VOC)		
Hazardous Air Pollutants	Potential Emissions	
	PPH	TPY
Regulated Pollutants other than Criteria and HAP	Potential Emissions	
	PPH	TPY

List the method(s) used to calculate the potential emissions (include dates of any stack tests conducted, versions of software used, source and dates of emission factors, etc.).

Applicable Requirements

List all applicable requirements for this emission unit. For each applicable requirement, include the underlying rule/regulation citation and/or construction permit with the condition number. (Note: Title V permit condition numbers alone are not the underlying applicable requirements). If an emission limit is calculated based on the type of source and design capacity or if a standard is based on a design parameter, this information should also be included.

From current Title V permit:

____ Permit Shield

For all applicable requirements listed above, provide monitoring/testing/recordkeeping/reporting which shall be used to demonstrate compliance. If the method is based on a permit or rule, include the condition number or citation. (Note: Each requirement listed above must have an associated method of demonstrating compliance. If there is not already a required method in place, then a method must be proposed.)

From current Title V permit:

Are you in compliance with all applicable requirements for this emission unit? Yes No

If no, complete the **Schedule of Compliance Form** as ATTACHMENT F.

ATTACHMENT E - Emission Unit Form

Emission Unit Description: *Storage Tank*

Emission unit ID number: 9509	Emission unit name: Tank 9509	List any control devices associated with this emission unit: N/A
---	---	--

Provide a description of the emission unit (type, method of operation, design parameters, etc.):
Storage tank.

Manufacturer:	Model number:	Serial number:
----------------------	----------------------	-----------------------

Construction date: See Attachment D Equipment Table	Installation date: See Attachment D Equipment Table	Modification date(s): See Attachment D Equipment Table
---	---	--

Design Capacity (examples: furnaces - tons/hr, tanks - gallons): See Attachment D Equipment Table

Maximum Hourly Throughput:	Maximum Annual Throughput:	Maximum Operating Schedule: 24 hrs/day, 365 days/yr
-----------------------------------	-----------------------------------	---

Fuel Usage Data (fill out all applicable fields)

Does this emission unit combust fuel? <input type="checkbox"/> Yes <input checked="" type="checkbox"/> No	If yes, is it? <input type="checkbox"/> Indirect Fired <input type="checkbox"/> Direct Fired
--	--

Maximum design heat input and/or maximum horsepower rating:	Type and Btu/hr rating of burners:
--	---

List the primary fuel type(s) and if applicable, the secondary fuel type(s). For each fuel type listed, provide the maximum hourly and annual fuel usage for each.

Describe each fuel expected to be used during the term of the permit.

Fuel Type	Max. Sulfur Content	Max. Ash Content	BTU Value

<i>Emissions Data</i>		
Criteria Pollutants	Potential Emissions	
	PPH	TPY
Carbon Monoxide (CO)		
Nitrogen Oxides (NO _x)		
Lead (Pb)		
Particulate Matter (PM _{2.5})		
Particulate Matter (PM ₁₀)		
Total Particulate Matter (TSP)		
Sulfur Dioxide (SO ₂)		
Volatile Organic Compounds (VOC)		
Hazardous Air Pollutants	Potential Emissions	
	PPH	TPY
Regulated Pollutants other than Criteria and HAP	Potential Emissions	
	PPH	TPY

List the method(s) used to calculate the potential emissions (include dates of any stack tests conducted, versions of software used, source and dates of emission factors, etc.).

Applicable Requirements

List all applicable requirements for this emission unit. For each applicable requirement, include the underlying rule/regulation citation and/or construction permit with the condition number. (Note: Title V permit condition numbers alone are not the underlying applicable requirements). If an emission limit is calculated based on the type of source and design capacity or if a standard is based on a design parameter, this information should also be included.

From current Title V permit:

____ Permit Shield

For all applicable requirements listed above, provide monitoring/testing/recordkeeping/reporting which shall be used to demonstrate compliance. If the method is based on a permit or rule, include the condition number or citation. (Note: Each requirement listed above must have an associated method of demonstrating compliance. If there is not already a required method in place, then a method must be proposed.)

From current Title V permit:

Are you in compliance with all applicable requirements for this emission unit? Yes No

If no, complete the **Schedule of Compliance Form** as ATTACHMENT F.

ATTACHMENT E - Emission Unit Form

Emission Unit Description: *Storage Tank*

Emission unit ID number: 9510	Emission unit name: Tank 9510	List any control devices associated with this emission unit: N/A
---	---	--

Provide a description of the emission unit (type, method of operation, design parameters, etc.):
Storage tank.

Manufacturer:	Model number:	Serial number:
----------------------	----------------------	-----------------------

Construction date: See Attachment D Equipment Table	Installation date: See Attachment D Equipment Table	Modification date(s): See Attachment D Equipment Table
---	---	--

Design Capacity (examples: furnaces - tons/hr, tanks - gallons): See Attachment D Equipment Table

Maximum Hourly Throughput:	Maximum Annual Throughput:	Maximum Operating Schedule: 24 hrs/day, 365 days/yr
-----------------------------------	-----------------------------------	---

Fuel Usage Data (fill out all applicable fields)

Does this emission unit combust fuel? <input type="checkbox"/> Yes <input checked="" type="checkbox"/> No	If yes, is it? <input type="checkbox"/> Indirect Fired <input type="checkbox"/> Direct Fired
--	--

Maximum design heat input and/or maximum horsepower rating:	Type and Btu/hr rating of burners:
--	---

List the primary fuel type(s) and if applicable, the secondary fuel type(s). For each fuel type listed, provide the maximum hourly and annual fuel usage for each.

Describe each fuel expected to be used during the term of the permit.

Fuel Type	Max. Sulfur Content	Max. Ash Content	BTU Value

<i>Emissions Data</i>		
Criteria Pollutants	Potential Emissions	
	PPH	TPY
Carbon Monoxide (CO)		
Nitrogen Oxides (NO _x)		
Lead (Pb)		
Particulate Matter (PM _{2.5})		
Particulate Matter (PM ₁₀)		
Total Particulate Matter (TSP)		
Sulfur Dioxide (SO ₂)		
Volatile Organic Compounds (VOC)		
Hazardous Air Pollutants	Potential Emissions	
	PPH	TPY
Regulated Pollutants other than Criteria and HAP	Potential Emissions	
	PPH	TPY

List the method(s) used to calculate the potential emissions (include dates of any stack tests conducted, versions of software used, source and dates of emission factors, etc.).

Applicable Requirements

List all applicable requirements for this emission unit. For each applicable requirement, include the underlying rule/regulation citation and/or construction permit with the condition number. (Note: Title V permit condition numbers alone are not the underlying applicable requirements). If an emission limit is calculated based on the type of source and design capacity or if a standard is based on a design parameter, this information should also be included.

From current Title V permit:

____ Permit Shield

For all applicable requirements listed above, provide monitoring/testing/recordkeeping/reporting which shall be used to demonstrate compliance. If the method is based on a permit or rule, include the condition number or citation. (Note: Each requirement listed above must have an associated method of demonstrating compliance. If there is not already a required method in place, then a method must be proposed.)

From current Title V permit:

Are you in compliance with all applicable requirements for this emission unit? Yes No

If no, complete the **Schedule of Compliance Form** as ATTACHMENT F.

ATTACHMENT E - Emission Unit Form

Emission Unit Description: *Storage Tank*

Emission unit ID number: 9511	Emission unit name: Tank 9511	List any control devices associated with this emission unit: N/A
---	---	--

Provide a description of the emission unit (type, method of operation, design parameters, etc.):
Storage tank.

Manufacturer:	Model number:	Serial number:
----------------------	----------------------	-----------------------

Construction date: See Attachment D Equipment Table	Installation date: See Attachment D Equipment Table	Modification date(s): See Attachment D Equipment Table
---	---	--

Design Capacity (examples: furnaces - tons/hr, tanks - gallons): See Attachment D Equipment Table

Maximum Hourly Throughput:	Maximum Annual Throughput:	Maximum Operating Schedule: 24 hrs/day, 365 days/yr
-----------------------------------	-----------------------------------	---

Fuel Usage Data (fill out all applicable fields)

Does this emission unit combust fuel? <input type="checkbox"/> Yes <input checked="" type="checkbox"/> No	If yes, is it? <input type="checkbox"/> Indirect Fired <input type="checkbox"/> Direct Fired
--	--

Maximum design heat input and/or maximum horsepower rating:	Type and Btu/hr rating of burners:
--	---

List the primary fuel type(s) and if applicable, the secondary fuel type(s). For each fuel type listed, provide the maximum hourly and annual fuel usage for each.

Describe each fuel expected to be used during the term of the permit.

Fuel Type	Max. Sulfur Content	Max. Ash Content	BTU Value

<i>Emissions Data</i>		
Criteria Pollutants	Potential Emissions	
	PPH	TPY
Carbon Monoxide (CO)		
Nitrogen Oxides (NO _x)		
Lead (Pb)		
Particulate Matter (PM _{2.5})		
Particulate Matter (PM ₁₀)		
Total Particulate Matter (TSP)		
Sulfur Dioxide (SO ₂)		
Volatile Organic Compounds (VOC)		
Hazardous Air Pollutants	Potential Emissions	
	PPH	TPY
Regulated Pollutants other than Criteria and HAP	Potential Emissions	
	PPH	TPY

List the method(s) used to calculate the potential emissions (include dates of any stack tests conducted, versions of software used, source and dates of emission factors, etc.).

Applicable Requirements

List all applicable requirements for this emission unit. For each applicable requirement, include the underlying rule/regulation citation and/or construction permit with the condition number. (Note: Title V permit condition numbers alone are not the underlying applicable requirements). If an emission limit is calculated based on the type of source and design capacity or if a standard is based on a design parameter, this information should also be included.

From current Title V permit:

____ Permit Shield

For all applicable requirements listed above, provide monitoring/testing/recordkeeping/reporting which shall be used to demonstrate compliance. If the method is based on a permit or rule, include the condition number or citation. (Note: Each requirement listed above must have an associated method of demonstrating compliance. If there is not already a required method in place, then a method must be proposed.)

From current Title V permit:

Are you in compliance with all applicable requirements for this emission unit? Yes No

If no, complete the **Schedule of Compliance Form** as ATTACHMENT F.

ATTACHMENT E - Emission Unit Form

Emission Unit Description: *Storage Tank*

Emission unit ID number: 9512	Emission unit name: Tank 9512	List any control devices associated with this emission unit: N/A
---	---	--

Provide a description of the emission unit (type, method of operation, design parameters, etc.):
Storage tank.

Manufacturer:	Model number:	Serial number:
----------------------	----------------------	-----------------------

Construction date: See Attachment D Equipment Table	Installation date: See Attachment D Equipment Table	Modification date(s): See Attachment D Equipment Table
---	---	--

Design Capacity (examples: furnaces - tons/hr, tanks - gallons): See Attachment D Equipment Table

Maximum Hourly Throughput:	Maximum Annual Throughput:	Maximum Operating Schedule: 24 hrs/day, 365 days/yr
-----------------------------------	-----------------------------------	---

Fuel Usage Data (fill out all applicable fields)

Does this emission unit combust fuel? ___Yes ___X___ No	If yes, is it? ___ Indirect Fired ___ Direct Fired
--	--

Maximum design heat input and/or maximum horsepower rating:	Type and Btu/hr rating of burners:
--	---

List the primary fuel type(s) and if applicable, the secondary fuel type(s). For each fuel type listed, provide the maximum hourly and annual fuel usage for each.

Describe each fuel expected to be used during the term of the permit.

Fuel Type	Max. Sulfur Content	Max. Ash Content	BTU Value

<i>Emissions Data</i>		
Criteria Pollutants	Potential Emissions	
	PPH	TPY
Carbon Monoxide (CO)		
Nitrogen Oxides (NO _x)		
Lead (Pb)		
Particulate Matter (PM _{2.5})		
Particulate Matter (PM ₁₀)		
Total Particulate Matter (TSP)		
Sulfur Dioxide (SO ₂)		
Volatile Organic Compounds (VOC)		
Hazardous Air Pollutants	Potential Emissions	
	PPH	TPY
Regulated Pollutants other than Criteria and HAP	Potential Emissions	
	PPH	TPY

List the method(s) used to calculate the potential emissions (include dates of any stack tests conducted, versions of software used, source and dates of emission factors, etc.).

Applicable Requirements

List all applicable requirements for this emission unit. For each applicable requirement, include the underlying rule/regulation citation and/or construction permit with the condition number. (Note: Title V permit condition numbers alone are not the underlying applicable requirements). If an emission limit is calculated based on the type of source and design capacity or if a standard is based on a design parameter, this information should also be included.

From current Title V permit:

____ Permit Shield

For all applicable requirements listed above, provide monitoring/testing/recordkeeping/reporting which shall be used to demonstrate compliance. If the method is based on a permit or rule, include the condition number or citation. (Note: Each requirement listed above must have an associated method of demonstrating compliance. If there is not already a required method in place, then a method must be proposed.)

From current Title V permit:

Are you in compliance with all applicable requirements for this emission unit? Yes No

If no, complete the **Schedule of Compliance Form** as ATTACHMENT F.

ATTACHMENT E - Emission Unit Form

Emission Unit Description: *Storage Tank*

Emission unit ID number: 9513	Emission unit name: Tank 9513	List any control devices associated with this emission unit: N/A
---	---	--

Provide a description of the emission unit (type, method of operation, design parameters, etc.):
Storage tank.

Manufacturer:	Model number:	Serial number:
----------------------	----------------------	-----------------------

Construction date: See Attachment D Equipment Table	Installation date: See Attachment D Equipment Table	Modification date(s): See Attachment D Equipment Table
---	---	--

Design Capacity (examples: furnaces - tons/hr, tanks - gallons): See Attachment D Equipment Table

Maximum Hourly Throughput:	Maximum Annual Throughput:	Maximum Operating Schedule: 24 hrs/day, 365 days/yr
-----------------------------------	-----------------------------------	---

Fuel Usage Data (fill out all applicable fields)

Does this emission unit combust fuel? <input type="checkbox"/> Yes <input checked="" type="checkbox"/> No	If yes, is it? <input type="checkbox"/> Indirect Fired <input type="checkbox"/> Direct Fired
--	--

Maximum design heat input and/or maximum horsepower rating:	Type and Btu/hr rating of burners:
--	---

List the primary fuel type(s) and if applicable, the secondary fuel type(s). For each fuel type listed, provide the maximum hourly and annual fuel usage for each.

Describe each fuel expected to be used during the term of the permit.

Fuel Type	Max. Sulfur Content	Max. Ash Content	BTU Value

<i>Emissions Data</i>		
Criteria Pollutants	Potential Emissions	
	PPH	TPY
Carbon Monoxide (CO)		
Nitrogen Oxides (NO _x)		
Lead (Pb)		
Particulate Matter (PM _{2.5})		
Particulate Matter (PM ₁₀)		
Total Particulate Matter (TSP)		
Sulfur Dioxide (SO ₂)		
Volatile Organic Compounds (VOC)		
Hazardous Air Pollutants	Potential Emissions	
	PPH	TPY
Regulated Pollutants other than Criteria and HAP	Potential Emissions	
	PPH	TPY

List the method(s) used to calculate the potential emissions (include dates of any stack tests conducted, versions of software used, source and dates of emission factors, etc.).

Applicable Requirements

List all applicable requirements for this emission unit. For each applicable requirement, include the underlying rule/regulation citation and/or construction permit with the condition number. (Note: Title V permit condition numbers alone are not the underlying applicable requirements). If an emission limit is calculated based on the type of source and design capacity or if a standard is based on a design parameter, this information should also be included.

From current Title V permit:

____ Permit Shield

For all applicable requirements listed above, provide monitoring/testing/recordkeeping/reporting which shall be used to demonstrate compliance. If the method is based on a permit or rule, include the condition number or citation. (Note: Each requirement listed above must have an associated method of demonstrating compliance. If there is not already a required method in place, then a method must be proposed.)

From current Title V permit:

Are you in compliance with all applicable requirements for this emission unit? Yes No

If no, complete the **Schedule of Compliance Form** as ATTACHMENT F.

ATTACHMENT E - Emission Unit Form

Emission Unit Description: *Storage Tank*

Emission unit ID number: 9514	Emission unit name: Tank 9514	List any control devices associated with this emission unit: N/A
---	---	--

Provide a description of the emission unit (type, method of operation, design parameters, etc.):
Storage tank.

Manufacturer:	Model number:	Serial number:
----------------------	----------------------	-----------------------

Construction date: See Attachment D Equipment Table	Installation date: See Attachment D Equipment Table	Modification date(s): See Attachment D Equipment Table
---	---	--

Design Capacity (examples: furnaces - tons/hr, tanks - gallons): See Attachment D Equipment Table

Maximum Hourly Throughput:	Maximum Annual Throughput:	Maximum Operating Schedule: 24 hrs/day, 365 days/yr
-----------------------------------	-----------------------------------	---

Fuel Usage Data (fill out all applicable fields)

Does this emission unit combust fuel? ___Yes ___X___ No	If yes, is it? ___ Indirect Fired ___ Direct Fired
--	--

Maximum design heat input and/or maximum horsepower rating:	Type and Btu/hr rating of burners:
--	---

List the primary fuel type(s) and if applicable, the secondary fuel type(s). For each fuel type listed, provide the maximum hourly and annual fuel usage for each.

Describe each fuel expected to be used during the term of the permit.

Fuel Type	Max. Sulfur Content	Max. Ash Content	BTU Value

<i>Emissions Data</i>		
Criteria Pollutants	Potential Emissions	
	PPH	TPY
Carbon Monoxide (CO)		
Nitrogen Oxides (NO _x)		
Lead (Pb)		
Particulate Matter (PM _{2.5})		
Particulate Matter (PM ₁₀)		
Total Particulate Matter (TSP)		
Sulfur Dioxide (SO ₂)		
Volatile Organic Compounds (VOC)		
Hazardous Air Pollutants	Potential Emissions	
	PPH	TPY
Regulated Pollutants other than Criteria and HAP	Potential Emissions	
	PPH	TPY

List the method(s) used to calculate the potential emissions (include dates of any stack tests conducted, versions of software used, source and dates of emission factors, etc.).

Applicable Requirements

List all applicable requirements for this emission unit. For each applicable requirement, include the underlying rule/regulation citation and/or construction permit with the condition number. (Note: Title V permit condition numbers alone are not the underlying applicable requirements). If an emission limit is calculated based on the type of source and design capacity or if a standard is based on a design parameter, this information should also be included.

From current Title V permit:

____ Permit Shield

For all applicable requirements listed above, provide monitoring/testing/recordkeeping/reporting which shall be used to demonstrate compliance. If the method is based on a permit or rule, include the condition number or citation. (Note: Each requirement listed above must have an associated method of demonstrating compliance. If there is not already a required method in place, then a method must be proposed.)

From current Title V permit:

Are you in compliance with all applicable requirements for this emission unit? Yes No

If no, complete the **Schedule of Compliance Form** as ATTACHMENT F.

ATTACHMENT E - Emission Unit Form

Emission Unit Description: *Storage Tank*

Emission unit ID number: 9550	Emission unit name: Tank 9550	List any control devices associated with this emission unit: N/A
---	---	--

Provide a description of the emission unit (type, method of operation, design parameters, etc.):
Storage tank.

Manufacturer:	Model number:	Serial number:
----------------------	----------------------	-----------------------

Construction date: See Attachment D Equipment Table	Installation date: See Attachment D Equipment Table	Modification date(s): See Attachment D Equipment Table
---	---	--

Design Capacity (examples: furnaces - tons/hr, tanks - gallons): See Attachment D Equipment Table

Maximum Hourly Throughput:	Maximum Annual Throughput:	Maximum Operating Schedule: 24 hrs/day, 365 days/yr
-----------------------------------	-----------------------------------	---

Fuel Usage Data (fill out all applicable fields)

Does this emission unit combust fuel? ___Yes ___X___ No	If yes, is it? ___ Indirect Fired ___ Direct Fired
--	--

Maximum design heat input and/or maximum horsepower rating:	Type and Btu/hr rating of burners:
--	---

List the primary fuel type(s) and if applicable, the secondary fuel type(s). For each fuel type listed, provide the maximum hourly and annual fuel usage for each.

Describe each fuel expected to be used during the term of the permit.

Fuel Type	Max. Sulfur Content	Max. Ash Content	BTU Value

<i>Emissions Data</i>		
Criteria Pollutants	Potential Emissions	
	PPH	TPY
Carbon Monoxide (CO)		
Nitrogen Oxides (NO _x)		
Lead (Pb)		
Particulate Matter (PM _{2.5})		
Particulate Matter (PM ₁₀)		
Total Particulate Matter (TSP)		
Sulfur Dioxide (SO ₂)		
Volatile Organic Compounds (VOC)		
Hazardous Air Pollutants	Potential Emissions	
	PPH	TPY
Regulated Pollutants other than Criteria and HAP	Potential Emissions	
	PPH	TPY

List the method(s) used to calculate the potential emissions (include dates of any stack tests conducted, versions of software used, source and dates of emission factors, etc.).

Applicable Requirements

List all applicable requirements for this emission unit. For each applicable requirement, include the underlying rule/regulation citation and/or construction permit with the condition number. (Note: Title V permit condition numbers alone are not the underlying applicable requirements). If an emission limit is calculated based on the type of source and design capacity or if a standard is based on a design parameter, this information should also be included.

From current Title V permit:

____ Permit Shield

For all applicable requirements listed above, provide monitoring/testing/recordkeeping/reporting which shall be used to demonstrate compliance. If the method is based on a permit or rule, include the condition number or citation. (Note: Each requirement listed above must have an associated method of demonstrating compliance. If there is not already a required method in place, then a method must be proposed.)

From current Title V permit:

Are you in compliance with all applicable requirements for this emission unit? Yes No

If no, complete the **Schedule of Compliance Form** as ATTACHMENT F.

ATTACHMENT E - Emission Unit Form

Emission Unit Description: *Storage Tank*

Emission unit ID number: 9551	Emission unit name: Tank 9551	List any control devices associated with this emission unit: N/A
---	---	--

Provide a description of the emission unit (type, method of operation, design parameters, etc.):
Storage tank.

Manufacturer:	Model number:	Serial number:
----------------------	----------------------	-----------------------

Construction date: See Attachment D Equipment Table	Installation date: See Attachment D Equipment Table	Modification date(s): See Attachment D Equipment Table
---	---	--

Design Capacity (examples: furnaces - tons/hr, tanks - gallons): See Attachment D Equipment Table

Maximum Hourly Throughput:	Maximum Annual Throughput:	Maximum Operating Schedule: 24 hrs/day, 365 days/yr
-----------------------------------	-----------------------------------	---

Fuel Usage Data (fill out all applicable fields)

Does this emission unit combust fuel? ___Yes ___X___ No	If yes, is it? ___ Indirect Fired ___ Direct Fired
--	--

Maximum design heat input and/or maximum horsepower rating:	Type and Btu/hr rating of burners:
--	---

List the primary fuel type(s) and if applicable, the secondary fuel type(s). For each fuel type listed, provide the maximum hourly and annual fuel usage for each.

Describe each fuel expected to be used during the term of the permit.

Fuel Type	Max. Sulfur Content	Max. Ash Content	BTU Value

<i>Emissions Data</i>		
Criteria Pollutants	Potential Emissions	
	PPH	TPY
Carbon Monoxide (CO)		
Nitrogen Oxides (NO _x)		
Lead (Pb)		
Particulate Matter (PM _{2.5})		
Particulate Matter (PM ₁₀)		
Total Particulate Matter (TSP)		
Sulfur Dioxide (SO ₂)		
Volatile Organic Compounds (VOC)		
Hazardous Air Pollutants	Potential Emissions	
	PPH	TPY
Regulated Pollutants other than Criteria and HAP	Potential Emissions	
	PPH	TPY

List the method(s) used to calculate the potential emissions (include dates of any stack tests conducted, versions of software used, source and dates of emission factors, etc.).

Applicable Requirements

List all applicable requirements for this emission unit. For each applicable requirement, include the underlying rule/regulation citation and/or construction permit with the condition number. (Note: Title V permit condition numbers alone are not the underlying applicable requirements). If an emission limit is calculated based on the type of source and design capacity or if a standard is based on a design parameter, this information should also be included.

From current Title V permit:

____ Permit Shield

For all applicable requirements listed above, provide monitoring/testing/recordkeeping/reporting which shall be used to demonstrate compliance. If the method is based on a permit or rule, include the condition number or citation. (Note: Each requirement listed above must have an associated method of demonstrating compliance. If there is not already a required method in place, then a method must be proposed.)

From current Title V permit:

Are you in compliance with all applicable requirements for this emission unit? Yes No

If no, complete the **Schedule of Compliance Form** as ATTACHMENT F.

ATTACHMENT E - Emission Unit Form

Emission Unit Description: *Storage Tank*

Emission unit ID number: 9552	Emission unit name: Tank 9552	List any control devices associated with this emission unit: N/A
---	---	--

Provide a description of the emission unit (type, method of operation, design parameters, etc.):
Storage tank.

Manufacturer:	Model number:	Serial number:
----------------------	----------------------	-----------------------

Construction date: See Attachment D Equipment Table	Installation date: See Attachment D Equipment Table	Modification date(s): See Attachment D Equipment Table
---	---	--

Design Capacity (examples: furnaces - tons/hr, tanks - gallons): See Attachment D Equipment Table

Maximum Hourly Throughput:	Maximum Annual Throughput:	Maximum Operating Schedule: 24 hrs/day, 365 days/yr
-----------------------------------	-----------------------------------	---

Fuel Usage Data (fill out all applicable fields)

Does this emission unit combust fuel? <input type="checkbox"/> Yes <input checked="" type="checkbox"/> No	If yes, is it? <input type="checkbox"/> Indirect Fired <input type="checkbox"/> Direct Fired
--	--

Maximum design heat input and/or maximum horsepower rating:	Type and Btu/hr rating of burners:
--	---

List the primary fuel type(s) and if applicable, the secondary fuel type(s). For each fuel type listed, provide the maximum hourly and annual fuel usage for each.

Describe each fuel expected to be used during the term of the permit.

Fuel Type	Max. Sulfur Content	Max. Ash Content	BTU Value

<i>Emissions Data</i>		
Criteria Pollutants	Potential Emissions	
	PPH	TPY
Carbon Monoxide (CO)		
Nitrogen Oxides (NO _x)		
Lead (Pb)		
Particulate Matter (PM _{2.5})		
Particulate Matter (PM ₁₀)		
Total Particulate Matter (TSP)		
Sulfur Dioxide (SO ₂)		
Volatile Organic Compounds (VOC)		
Hazardous Air Pollutants	Potential Emissions	
	PPH	TPY
Regulated Pollutants other than Criteria and HAP	Potential Emissions	
	PPH	TPY

List the method(s) used to calculate the potential emissions (include dates of any stack tests conducted, versions of software used, source and dates of emission factors, etc.).

Applicable Requirements

List all applicable requirements for this emission unit. For each applicable requirement, include the underlying rule/regulation citation and/or construction permit with the condition number. (Note: Title V permit condition numbers alone are not the underlying applicable requirements). If an emission limit is calculated based on the type of source and design capacity or if a standard is based on a design parameter, this information should also be included.

From current Title V permit:

____ Permit Shield

For all applicable requirements listed above, provide monitoring/testing/recordkeeping/reporting which shall be used to demonstrate compliance. If the method is based on a permit or rule, include the condition number or citation. (Note: Each requirement listed above must have an associated method of demonstrating compliance. If there is not already a required method in place, then a method must be proposed.)

From current Title V permit:

Are you in compliance with all applicable requirements for this emission unit? Yes No

If no, complete the **Schedule of Compliance Form** as ATTACHMENT F.

ATTACHMENT E - Emission Unit Form

Emission Unit Description: *Storage Tank*

Emission unit ID number: 9553	Emission unit name: Tank 9553	List any control devices associated with this emission unit: N/A
---	---	--

Provide a description of the emission unit (type, method of operation, design parameters, etc.):
Storage tank.

Manufacturer:	Model number:	Serial number:
----------------------	----------------------	-----------------------

Construction date: See Attachment D Equipment Table	Installation date: See Attachment D Equipment Table	Modification date(s): See Attachment D Equipment Table
---	---	--

Design Capacity (examples: furnaces - tons/hr, tanks - gallons): See Attachment D Equipment Table

Maximum Hourly Throughput:	Maximum Annual Throughput:	Maximum Operating Schedule: 24 hrs/day, 365 days/yr
-----------------------------------	-----------------------------------	---

Fuel Usage Data (fill out all applicable fields)

Does this emission unit combust fuel? ___Yes ___X___ No	If yes, is it? ___ Indirect Fired ___ Direct Fired
--	--

Maximum design heat input and/or maximum horsepower rating:	Type and Btu/hr rating of burners:
--	---

List the primary fuel type(s) and if applicable, the secondary fuel type(s). For each fuel type listed, provide the maximum hourly and annual fuel usage for each.

Describe each fuel expected to be used during the term of the permit.

Fuel Type	Max. Sulfur Content	Max. Ash Content	BTU Value

<i>Emissions Data</i>		
Criteria Pollutants	Potential Emissions	
	PPH	TPY
Carbon Monoxide (CO)		
Nitrogen Oxides (NO _x)		
Lead (Pb)		
Particulate Matter (PM _{2.5})		
Particulate Matter (PM ₁₀)		
Total Particulate Matter (TSP)		
Sulfur Dioxide (SO ₂)		
Volatile Organic Compounds (VOC)		
Hazardous Air Pollutants	Potential Emissions	
	PPH	TPY
Regulated Pollutants other than Criteria and HAP	Potential Emissions	
	PPH	TPY

List the method(s) used to calculate the potential emissions (include dates of any stack tests conducted, versions of software used, source and dates of emission factors, etc.).

Applicable Requirements

List all applicable requirements for this emission unit. For each applicable requirement, include the underlying rule/regulation citation and/or construction permit with the condition number. (Note: Title V permit condition numbers alone are not the underlying applicable requirements). If an emission limit is calculated based on the type of source and design capacity or if a standard is based on a design parameter, this information should also be included.

From current Title V permit:

____ Permit Shield

For all applicable requirements listed above, provide monitoring/testing/recordkeeping/reporting which shall be used to demonstrate compliance. If the method is based on a permit or rule, include the condition number or citation. (Note: Each requirement listed above must have an associated method of demonstrating compliance. If there is not already a required method in place, then a method must be proposed.)

From current Title V permit:

Are you in compliance with all applicable requirements for this emission unit? Yes No

If no, complete the **Schedule of Compliance Form** as ATTACHMENT F.

ATTACHMENT E - Emission Unit Form

Emission Unit Description: *Storage Tank*

Emission unit ID number: 9554	Emission unit name: Tank 9554	List any control devices associated with this emission unit: N/A
---	---	--

Provide a description of the emission unit (type, method of operation, design parameters, etc.):
Storage tank.

Manufacturer:	Model number:	Serial number:
----------------------	----------------------	-----------------------

Construction date: See Attachment D Equipment Table	Installation date: See Attachment D Equipment Table	Modification date(s): See Attachment D Equipment Table
---	---	--

Design Capacity (examples: furnaces - tons/hr, tanks - gallons): See Attachment D Equipment Table

Maximum Hourly Throughput:	Maximum Annual Throughput:	Maximum Operating Schedule: 24 hrs/day, 365 days/yr
-----------------------------------	-----------------------------------	---

Fuel Usage Data (fill out all applicable fields)

Does this emission unit combust fuel? <input type="checkbox"/> Yes <input checked="" type="checkbox"/> No	If yes, is it? <input type="checkbox"/> Indirect Fired <input type="checkbox"/> Direct Fired
--	--

Maximum design heat input and/or maximum horsepower rating:	Type and Btu/hr rating of burners:
--	---

List the primary fuel type(s) and if applicable, the secondary fuel type(s). For each fuel type listed, provide the maximum hourly and annual fuel usage for each.

Describe each fuel expected to be used during the term of the permit.

Fuel Type	Max. Sulfur Content	Max. Ash Content	BTU Value

<i>Emissions Data</i>		
Criteria Pollutants	Potential Emissions	
	PPH	TPY
Carbon Monoxide (CO)		
Nitrogen Oxides (NO _x)		
Lead (Pb)		
Particulate Matter (PM _{2.5})		
Particulate Matter (PM ₁₀)		
Total Particulate Matter (TSP)		
Sulfur Dioxide (SO ₂)		
Volatile Organic Compounds (VOC)		
Hazardous Air Pollutants	Potential Emissions	
	PPH	TPY
Regulated Pollutants other than Criteria and HAP	Potential Emissions	
	PPH	TPY

List the method(s) used to calculate the potential emissions (include dates of any stack tests conducted, versions of software used, source and dates of emission factors, etc.).

Applicable Requirements

List all applicable requirements for this emission unit. For each applicable requirement, include the underlying rule/regulation citation and/or construction permit with the condition number. (Note: Title V permit condition numbers alone are not the underlying applicable requirements). If an emission limit is calculated based on the type of source and design capacity or if a standard is based on a design parameter, this information should also be included.

From current Title V permit:

____ Permit Shield

For all applicable requirements listed above, provide monitoring/testing/recordkeeping/reporting which shall be used to demonstrate compliance. If the method is based on a permit or rule, include the condition number or citation. (Note: Each requirement listed above must have an associated method of demonstrating compliance. If there is not already a required method in place, then a method must be proposed.)

From current Title V permit:

Are you in compliance with all applicable requirements for this emission unit? Yes No

If no, complete the **Schedule of Compliance Form** as ATTACHMENT F.

ATTACHMENT E - Emission Unit Form

Emission Unit Description: *Storage Tank*

Emission unit ID number: 9555	Emission unit name: Tank 9555	List any control devices associated with this emission unit: N/A
---	---	--

Provide a description of the emission unit (type, method of operation, design parameters, etc.):
Storage tank.

Manufacturer:	Model number:	Serial number:
----------------------	----------------------	-----------------------

Construction date: See Attachment D Equipment Table	Installation date: See Attachment D Equipment Table	Modification date(s): See Attachment D Equipment Table
---	---	--

Design Capacity (examples: furnaces - tons/hr, tanks - gallons): See Attachment D Equipment Table

Maximum Hourly Throughput:	Maximum Annual Throughput:	Maximum Operating Schedule: 24 hrs/day, 365 days/yr
-----------------------------------	-----------------------------------	---

Fuel Usage Data (fill out all applicable fields)

Does this emission unit combust fuel? <input type="checkbox"/> Yes <input checked="" type="checkbox"/> No	If yes, is it? <input type="checkbox"/> Indirect Fired <input type="checkbox"/> Direct Fired
--	--

Maximum design heat input and/or maximum horsepower rating:	Type and Btu/hr rating of burners:
--	---

List the primary fuel type(s) and if applicable, the secondary fuel type(s). For each fuel type listed, provide the maximum hourly and annual fuel usage for each.

Describe each fuel expected to be used during the term of the permit.

Fuel Type	Max. Sulfur Content	Max. Ash Content	BTU Value

<i>Emissions Data</i>		
Criteria Pollutants	Potential Emissions	
	PPH	TPY
Carbon Monoxide (CO)		
Nitrogen Oxides (NO _x)		
Lead (Pb)		
Particulate Matter (PM _{2.5})		
Particulate Matter (PM ₁₀)		
Total Particulate Matter (TSP)		
Sulfur Dioxide (SO ₂)		
Volatile Organic Compounds (VOC)		
Hazardous Air Pollutants	Potential Emissions	
	PPH	TPY
Regulated Pollutants other than Criteria and HAP	Potential Emissions	
	PPH	TPY

List the method(s) used to calculate the potential emissions (include dates of any stack tests conducted, versions of software used, source and dates of emission factors, etc.).

Applicable Requirements

List all applicable requirements for this emission unit. For each applicable requirement, include the underlying rule/regulation citation and/or construction permit with the condition number. (Note: Title V permit condition numbers alone are not the underlying applicable requirements). If an emission limit is calculated based on the type of source and design capacity or if a standard is based on a design parameter, this information should also be included.

From current Title V permit:

____ Permit Shield

For all applicable requirements listed above, provide monitoring/testing/recordkeeping/reporting which shall be used to demonstrate compliance. If the method is based on a permit or rule, include the condition number or citation. (Note: Each requirement listed above must have an associated method of demonstrating compliance. If there is not already a required method in place, then a method must be proposed.)

From current Title V permit:

Are you in compliance with all applicable requirements for this emission unit? Yes No

If no, complete the **Schedule of Compliance Form** as ATTACHMENT F.

ATTACHMENT E - Emission Unit Form

Emission Unit Description: <i>Storage Tank</i>			
Emission unit ID number: 9556	Emission unit name: Tank 9556	List any control devices associated with this emission unit: N/A	
Provide a description of the emission unit (type, method of operation, design parameters, etc.): Storage tank.			
Manufacturer:	Model number:	Serial number:	
Construction date: See Attachment D Equipment Table	Installation date: See Attachment D Equipment Table	Modification date(s): See Attachment D Equipment Table	
Design Capacity (examples: furnaces - tons/hr, tanks - gallons): See Attachment D Equipment Table			
Maximum Hourly Throughput:	Maximum Annual Throughput:	Maximum Operating Schedule: 24 hrs/day, 365 days/yr	
Fuel Usage Data (fill out all applicable fields)			
Does this emission unit combust fuel? <input type="checkbox"/> Yes <input checked="" type="checkbox"/> No		If yes, is it? <input type="checkbox"/> Indirect Fired <input type="checkbox"/> Direct Fired	
Maximum design heat input and/or maximum horsepower rating:		Type and Btu/hr rating of burners:	
List the primary fuel type(s) and if applicable, the secondary fuel type(s). For each fuel type listed, provide the maximum hourly and annual fuel usage for each.			
Describe each fuel expected to be used during the term of the permit.			
Fuel Type	Max. Sulfur Content	Max. Ash Content	BTU Value

<i>Emissions Data</i>		
Criteria Pollutants	Potential Emissions	
	PPH	TPY
Carbon Monoxide (CO)		
Nitrogen Oxides (NO _x)		
Lead (Pb)		
Particulate Matter (PM _{2.5})		
Particulate Matter (PM ₁₀)		
Total Particulate Matter (TSP)		
Sulfur Dioxide (SO ₂)		
Volatile Organic Compounds (VOC)		
Hazardous Air Pollutants	Potential Emissions	
	PPH	TPY
Regulated Pollutants other than Criteria and HAP	Potential Emissions	
	PPH	TPY

List the method(s) used to calculate the potential emissions (include dates of any stack tests conducted, versions of software used, source and dates of emission factors, etc.).

Applicable Requirements

List all applicable requirements for this emission unit. For each applicable requirement, include the underlying rule/regulation citation and/or construction permit with the condition number. (Note: Title V permit condition numbers alone are not the underlying applicable requirements). If an emission limit is calculated based on the type of source and design capacity or if a standard is based on a design parameter, this information should also be included.

From current Title V permit:

____ Permit Shield

For all applicable requirements listed above, provide monitoring/testing/recordkeeping/reporting which shall be used to demonstrate compliance. If the method is based on a permit or rule, include the condition number or citation. (Note: Each requirement listed above must have an associated method of demonstrating compliance. If there is not already a required method in place, then a method must be proposed.)

From current Title V permit:

Are you in compliance with all applicable requirements for this emission unit? Yes No

If no, complete the **Schedule of Compliance Form** as ATTACHMENT F.

ATTACHMENT E - Emission Unit Form

Emission Unit Description: *Storage Tank*

Emission unit ID number: 9557	Emission unit name: Tank 9557	List any control devices associated with this emission unit: N/A
---	---	--

Provide a description of the emission unit (type, method of operation, design parameters, etc.):
Storage tank.

Manufacturer:	Model number:	Serial number:
----------------------	----------------------	-----------------------

Construction date: See Attachment D Equipment Table	Installation date: See Attachment D Equipment Table	Modification date(s): See Attachment D Equipment Table
---	---	--

Design Capacity (examples: furnaces - tons/hr, tanks - gallons): See Attachment D Equipment Table

Maximum Hourly Throughput:	Maximum Annual Throughput:	Maximum Operating Schedule: 24 hrs/day, 365 days/yr
-----------------------------------	-----------------------------------	---

Fuel Usage Data (fill out all applicable fields)

Does this emission unit combust fuel? <input type="checkbox"/> Yes <input checked="" type="checkbox"/> No	If yes, is it? <input type="checkbox"/> Indirect Fired <input type="checkbox"/> Direct Fired
--	--

Maximum design heat input and/or maximum horsepower rating:	Type and Btu/hr rating of burners:
--	---

List the primary fuel type(s) and if applicable, the secondary fuel type(s). For each fuel type listed, provide the maximum hourly and annual fuel usage for each.

Describe each fuel expected to be used during the term of the permit.

Fuel Type	Max. Sulfur Content	Max. Ash Content	BTU Value

<i>Emissions Data</i>		
Criteria Pollutants	Potential Emissions	
	PPH	TPY
Carbon Monoxide (CO)		
Nitrogen Oxides (NO _x)		
Lead (Pb)		
Particulate Matter (PM _{2.5})		
Particulate Matter (PM ₁₀)		
Total Particulate Matter (TSP)		
Sulfur Dioxide (SO ₂)		
Volatile Organic Compounds (VOC)		
Hazardous Air Pollutants	Potential Emissions	
	PPH	TPY
Regulated Pollutants other than Criteria and HAP	Potential Emissions	
	PPH	TPY

List the method(s) used to calculate the potential emissions (include dates of any stack tests conducted, versions of software used, source and dates of emission factors, etc.).

Applicable Requirements

List all applicable requirements for this emission unit. For each applicable requirement, include the underlying rule/regulation citation and/or construction permit with the condition number. (Note: Title V permit condition numbers alone are not the underlying applicable requirements). If an emission limit is calculated based on the type of source and design capacity or if a standard is based on a design parameter, this information should also be included.

From current Title V permit:

____ Permit Shield

For all applicable requirements listed above, provide monitoring/testing/recordkeeping/reporting which shall be used to demonstrate compliance. If the method is based on a permit or rule, include the condition number or citation. (Note: Each requirement listed above must have an associated method of demonstrating compliance. If there is not already a required method in place, then a method must be proposed.)

From current Title V permit:

Are you in compliance with all applicable requirements for this emission unit? Yes No

If no, complete the **Schedule of Compliance Form** as ATTACHMENT F.

ATTACHMENT E - Emission Unit Form

Emission Unit Description: *Storage Tank*

Emission unit ID number: 9558	Emission unit name: Tank 9558	List any control devices associated with this emission unit: N/A
---	---	--

Provide a description of the emission unit (type, method of operation, design parameters, etc.):
Storage tank.

Manufacturer:	Model number:	Serial number:
----------------------	----------------------	-----------------------

Construction date: See Attachment D Equipment Table	Installation date: See Attachment D Equipment Table	Modification date(s): See Attachment D Equipment Table
---	---	--

Design Capacity (examples: furnaces - tons/hr, tanks - gallons): See Attachment D Equipment Table

Maximum Hourly Throughput:	Maximum Annual Throughput:	Maximum Operating Schedule: 24 hrs/day, 365 days/yr
-----------------------------------	-----------------------------------	---

Fuel Usage Data (fill out all applicable fields)

Does this emission unit combust fuel? <input type="checkbox"/> Yes <input checked="" type="checkbox"/> No	If yes, is it? <input type="checkbox"/> Indirect Fired <input type="checkbox"/> Direct Fired
--	--

Maximum design heat input and/or maximum horsepower rating:	Type and Btu/hr rating of burners:
--	---

List the primary fuel type(s) and if applicable, the secondary fuel type(s). For each fuel type listed, provide the maximum hourly and annual fuel usage for each.

Describe each fuel expected to be used during the term of the permit.

Fuel Type	Max. Sulfur Content	Max. Ash Content	BTU Value

<i>Emissions Data</i>		
Criteria Pollutants	Potential Emissions	
	PPH	TPY
Carbon Monoxide (CO)		
Nitrogen Oxides (NO _x)		
Lead (Pb)		
Particulate Matter (PM _{2.5})		
Particulate Matter (PM ₁₀)		
Total Particulate Matter (TSP)		
Sulfur Dioxide (SO ₂)		
Volatile Organic Compounds (VOC)		
Hazardous Air Pollutants	Potential Emissions	
	PPH	TPY
Regulated Pollutants other than Criteria and HAP	Potential Emissions	
	PPH	TPY

List the method(s) used to calculate the potential emissions (include dates of any stack tests conducted, versions of software used, source and dates of emission factors, etc.).

Applicable Requirements

List all applicable requirements for this emission unit. For each applicable requirement, include the underlying rule/regulation citation and/or construction permit with the condition number. (Note: Title V permit condition numbers alone are not the underlying applicable requirements). If an emission limit is calculated based on the type of source and design capacity or if a standard is based on a design parameter, this information should also be included.

From current Title V permit:

____ Permit Shield

For all applicable requirements listed above, provide monitoring/testing/recordkeeping/reporting which shall be used to demonstrate compliance. If the method is based on a permit or rule, include the condition number or citation. (Note: Each requirement listed above must have an associated method of demonstrating compliance. If there is not already a required method in place, then a method must be proposed.)

From current Title V permit:

Are you in compliance with all applicable requirements for this emission unit? Yes No

If no, complete the **Schedule of Compliance Form** as ATTACHMENT F.

ATTACHMENT E - Emission Unit Form

Emission Unit Description: *Storage Tank*

Emission unit ID number: 9559	Emission unit name: Tank 9559	List any control devices associated with this emission unit: N/A
---	---	--

Provide a description of the emission unit (type, method of operation, design parameters, etc.):
Storage tank.

Manufacturer:	Model number:	Serial number:
----------------------	----------------------	-----------------------

Construction date: See Attachment D Equipment Table	Installation date: See Attachment D Equipment Table	Modification date(s): See Attachment D Equipment Table
---	---	--

Design Capacity (examples: furnaces - tons/hr, tanks - gallons): See Attachment D Equipment Table

Maximum Hourly Throughput:	Maximum Annual Throughput:	Maximum Operating Schedule: 24 hrs/day, 365 days/yr
-----------------------------------	-----------------------------------	---

Fuel Usage Data (fill out all applicable fields)

Does this emission unit combust fuel? <input type="checkbox"/> Yes <input checked="" type="checkbox"/> No	If yes, is it? <input type="checkbox"/> Indirect Fired <input type="checkbox"/> Direct Fired
--	--

Maximum design heat input and/or maximum horsepower rating:	Type and Btu/hr rating of burners:
--	---

List the primary fuel type(s) and if applicable, the secondary fuel type(s). For each fuel type listed, provide the maximum hourly and annual fuel usage for each.

Describe each fuel expected to be used during the term of the permit.

Fuel Type	Max. Sulfur Content	Max. Ash Content	BTU Value

<i>Emissions Data</i>		
Criteria Pollutants	Potential Emissions	
	PPH	TPY
Carbon Monoxide (CO)		
Nitrogen Oxides (NO _x)		
Lead (Pb)		
Particulate Matter (PM _{2.5})		
Particulate Matter (PM ₁₀)		
Total Particulate Matter (TSP)		
Sulfur Dioxide (SO ₂)		
Volatile Organic Compounds (VOC)		
Hazardous Air Pollutants	Potential Emissions	
	PPH	TPY
Regulated Pollutants other than Criteria and HAP	Potential Emissions	
	PPH	TPY

List the method(s) used to calculate the potential emissions (include dates of any stack tests conducted, versions of software used, source and dates of emission factors, etc.).

Applicable Requirements

List all applicable requirements for this emission unit. For each applicable requirement, include the underlying rule/regulation citation and/or construction permit with the condition number. (Note: Title V permit condition numbers alone are not the underlying applicable requirements). If an emission limit is calculated based on the type of source and design capacity or if a standard is based on a design parameter, this information should also be included.

From current Title V permit:

____ Permit Shield

For all applicable requirements listed above, provide monitoring/testing/recordkeeping/reporting which shall be used to demonstrate compliance. If the method is based on a permit or rule, include the condition number or citation. (Note: Each requirement listed above must have an associated method of demonstrating compliance. If there is not already a required method in place, then a method must be proposed.)

From current Title V permit:

Are you in compliance with all applicable requirements for this emission unit? Yes No

If no, complete the **Schedule of Compliance Form** as ATTACHMENT F.

ATTACHMENT E - Emission Unit Form

Emission Unit Description: *Storage Tank*

Emission unit ID number: 9560	Emission unit name: Tank 9560	List any control devices associated with this emission unit: N/A
---	---	--

Provide a description of the emission unit (type, method of operation, design parameters, etc.):
Storage tank.

Manufacturer:	Model number:	Serial number:
----------------------	----------------------	-----------------------

Construction date: See Attachment D Equipment Table	Installation date: See Attachment D Equipment Table	Modification date(s): See Attachment D Equipment Table
---	---	--

Design Capacity (examples: furnaces - tons/hr, tanks - gallons): See Attachment D Equipment Table

Maximum Hourly Throughput:	Maximum Annual Throughput:	Maximum Operating Schedule: 24 hrs/day, 365 days/yr
-----------------------------------	-----------------------------------	---

Fuel Usage Data (fill out all applicable fields)

Does this emission unit combust fuel? ___Yes ___X___ No	If yes, is it? ___ Indirect Fired ___ Direct Fired
--	--

Maximum design heat input and/or maximum horsepower rating:	Type and Btu/hr rating of burners:
--	---

List the primary fuel type(s) and if applicable, the secondary fuel type(s). For each fuel type listed, provide the maximum hourly and annual fuel usage for each.

Describe each fuel expected to be used during the term of the permit.

Fuel Type	Max. Sulfur Content	Max. Ash Content	BTU Value

<i>Emissions Data</i>		
Criteria Pollutants	Potential Emissions	
	PPH	TPY
Carbon Monoxide (CO)		
Nitrogen Oxides (NO _x)		
Lead (Pb)		
Particulate Matter (PM _{2.5})		
Particulate Matter (PM ₁₀)		
Total Particulate Matter (TSP)		
Sulfur Dioxide (SO ₂)		
Volatile Organic Compounds (VOC)		
Hazardous Air Pollutants	Potential Emissions	
	PPH	TPY
Regulated Pollutants other than Criteria and HAP	Potential Emissions	
	PPH	TPY

List the method(s) used to calculate the potential emissions (include dates of any stack tests conducted, versions of software used, source and dates of emission factors, etc.).

Applicable Requirements

List all applicable requirements for this emission unit. For each applicable requirement, include the underlying rule/regulation citation and/or construction permit with the condition number. (Note: Title V permit condition numbers alone are not the underlying applicable requirements). If an emission limit is calculated based on the type of source and design capacity or if a standard is based on a design parameter, this information should also be included.

From current Title V permit:

____ Permit Shield

For all applicable requirements listed above, provide monitoring/testing/recordkeeping/reporting which shall be used to demonstrate compliance. If the method is based on a permit or rule, include the condition number or citation. (Note: Each requirement listed above must have an associated method of demonstrating compliance. If there is not already a required method in place, then a method must be proposed.)

From current Title V permit:

Are you in compliance with all applicable requirements for this emission unit? Yes No

If no, complete the **Schedule of Compliance Form** as ATTACHMENT F.

ATTACHMENT E - Emission Unit Form

Emission Unit Description: *Storage Tank*

Emission unit ID number: 9562	Emission unit name: Tank 9562	List any control devices associated with this emission unit: N/A
---	---	--

Provide a description of the emission unit (type, method of operation, design parameters, etc.):
Storage tank.

Manufacturer:	Model number:	Serial number:
----------------------	----------------------	-----------------------

Construction date: See Attachment D Equipment Table	Installation date: See Attachment D Equipment Table	Modification date(s): See Attachment D Equipment Table
---	---	--

Design Capacity (examples: furnaces - tons/hr, tanks - gallons): See Attachment D Equipment Table

Maximum Hourly Throughput:	Maximum Annual Throughput:	Maximum Operating Schedule: 24 hrs/day, 365 days/yr
-----------------------------------	-----------------------------------	---

Fuel Usage Data (fill out all applicable fields)

Does this emission unit combust fuel? <input type="checkbox"/> Yes <input checked="" type="checkbox"/> No	If yes, is it? <input type="checkbox"/> Indirect Fired <input type="checkbox"/> Direct Fired
--	--

Maximum design heat input and/or maximum horsepower rating:	Type and Btu/hr rating of burners:
--	---

List the primary fuel type(s) and if applicable, the secondary fuel type(s). For each fuel type listed, provide the maximum hourly and annual fuel usage for each.

Describe each fuel expected to be used during the term of the permit.

Fuel Type	Max. Sulfur Content	Max. Ash Content	BTU Value

<i>Emissions Data</i>		
Criteria Pollutants	Potential Emissions	
	PPH	TPY
Carbon Monoxide (CO)		
Nitrogen Oxides (NO _x)		
Lead (Pb)		
Particulate Matter (PM _{2.5})		
Particulate Matter (PM ₁₀)		
Total Particulate Matter (TSP)		
Sulfur Dioxide (SO ₂)		
Volatile Organic Compounds (VOC)		
Hazardous Air Pollutants	Potential Emissions	
	PPH	TPY
Regulated Pollutants other than Criteria and HAP	Potential Emissions	
	PPH	TPY

List the method(s) used to calculate the potential emissions (include dates of any stack tests conducted, versions of software used, source and dates of emission factors, etc.).

Applicable Requirements

List all applicable requirements for this emission unit. For each applicable requirement, include the underlying rule/regulation citation and/or construction permit with the condition number. (Note: Title V permit condition numbers alone are not the underlying applicable requirements). If an emission limit is calculated based on the type of source and design capacity or if a standard is based on a design parameter, this information should also be included.

From current Title V permit:

____ Permit Shield

For all applicable requirements listed above, provide monitoring/testing/recordkeeping/reporting which shall be used to demonstrate compliance. If the method is based on a permit or rule, include the condition number or citation. (Note: Each requirement listed above must have an associated method of demonstrating compliance. If there is not already a required method in place, then a method must be proposed.)

From current Title V permit:

Are you in compliance with all applicable requirements for this emission unit? Yes No

If no, complete the **Schedule of Compliance Form** as ATTACHMENT F.

ATTACHMENT E - Emission Unit Form

Emission Unit Description: *Storage Tank*

Emission unit ID number: 9563	Emission unit name: Tank 9563	List any control devices associated with this emission unit: N/A
---	---	--

Provide a description of the emission unit (type, method of operation, design parameters, etc.):
Storage tank.

Manufacturer:	Model number:	Serial number:
----------------------	----------------------	-----------------------

Construction date: See Attachment D Equipment Table	Installation date: See Attachment D Equipment Table	Modification date(s): See Attachment D Equipment Table
---	---	--

Design Capacity (examples: furnaces - tons/hr, tanks - gallons): See Attachment D Equipment Table

Maximum Hourly Throughput:	Maximum Annual Throughput:	Maximum Operating Schedule: 24 hrs/day, 365 days/yr
-----------------------------------	-----------------------------------	---

Fuel Usage Data (fill out all applicable fields)

Does this emission unit combust fuel? ___Yes ___X___ No	If yes, is it? ___ Indirect Fired ___ Direct Fired
--	--

Maximum design heat input and/or maximum horsepower rating:	Type and Btu/hr rating of burners:
--	---

List the primary fuel type(s) and if applicable, the secondary fuel type(s). For each fuel type listed, provide the maximum hourly and annual fuel usage for each.

Describe each fuel expected to be used during the term of the permit.

Fuel Type	Max. Sulfur Content	Max. Ash Content	BTU Value

<i>Emissions Data</i>		
Criteria Pollutants	Potential Emissions	
	PPH	TPY
Carbon Monoxide (CO)		
Nitrogen Oxides (NO _x)		
Lead (Pb)		
Particulate Matter (PM _{2.5})		
Particulate Matter (PM ₁₀)		
Total Particulate Matter (TSP)		
Sulfur Dioxide (SO ₂)		
Volatile Organic Compounds (VOC)		
Hazardous Air Pollutants	Potential Emissions	
	PPH	TPY
Regulated Pollutants other than Criteria and HAP	Potential Emissions	
	PPH	TPY

List the method(s) used to calculate the potential emissions (include dates of any stack tests conducted, versions of software used, source and dates of emission factors, etc.).

Applicable Requirements

List all applicable requirements for this emission unit. For each applicable requirement, include the underlying rule/regulation citation and/or construction permit with the condition number. (Note: Title V permit condition numbers alone are not the underlying applicable requirements). If an emission limit is calculated based on the type of source and design capacity or if a standard is based on a design parameter, this information should also be included.

From current Title V permit:

____ Permit Shield

For all applicable requirements listed above, provide monitoring/testing/recordkeeping/reporting which shall be used to demonstrate compliance. If the method is based on a permit or rule, include the condition number or citation. (Note: Each requirement listed above must have an associated method of demonstrating compliance. If there is not already a required method in place, then a method must be proposed.)

From current Title V permit:

Are you in compliance with all applicable requirements for this emission unit? Yes No

If no, complete the **Schedule of Compliance Form** as ATTACHMENT F.

ATTACHMENT E - Emission Unit Form

Emission Unit Description: *Storage Tank*

Emission unit ID number: 9564	Emission unit name: Tank 9564	List any control devices associated with this emission unit: N/A
---	---	--

Provide a description of the emission unit (type, method of operation, design parameters, etc.):
Storage tank.

Manufacturer:	Model number:	Serial number:
----------------------	----------------------	-----------------------

Construction date: See Attachment D Equipment Table	Installation date: See Attachment D Equipment Table	Modification date(s): See Attachment D Equipment Table
---	---	--

Design Capacity (examples: furnaces - tons/hr, tanks - gallons): See Attachment D Equipment Table

Maximum Hourly Throughput:	Maximum Annual Throughput:	Maximum Operating Schedule: 24 hrs/day, 365 days/yr
-----------------------------------	-----------------------------------	---

Fuel Usage Data (fill out all applicable fields)

Does this emission unit combust fuel? ___Yes ___X___ No	If yes, is it? ___ Indirect Fired ___ Direct Fired
--	--

Maximum design heat input and/or maximum horsepower rating:	Type and Btu/hr rating of burners:
--	---

List the primary fuel type(s) and if applicable, the secondary fuel type(s). For each fuel type listed, provide the maximum hourly and annual fuel usage for each.

Describe each fuel expected to be used during the term of the permit.

Fuel Type	Max. Sulfur Content	Max. Ash Content	BTU Value

<i>Emissions Data</i>		
Criteria Pollutants	Potential Emissions	
	PPH	TPY
Carbon Monoxide (CO)		
Nitrogen Oxides (NO _x)		
Lead (Pb)		
Particulate Matter (PM _{2.5})		
Particulate Matter (PM ₁₀)		
Total Particulate Matter (TSP)		
Sulfur Dioxide (SO ₂)		
Volatile Organic Compounds (VOC)		
Hazardous Air Pollutants	Potential Emissions	
	PPH	TPY
Regulated Pollutants other than Criteria and HAP	Potential Emissions	
	PPH	TPY

List the method(s) used to calculate the potential emissions (include dates of any stack tests conducted, versions of software used, source and dates of emission factors, etc.).

Applicable Requirements

List all applicable requirements for this emission unit. For each applicable requirement, include the underlying rule/regulation citation and/or construction permit with the condition number. (Note: Title V permit condition numbers alone are not the underlying applicable requirements). If an emission limit is calculated based on the type of source and design capacity or if a standard is based on a design parameter, this information should also be included.

From current Title V permit:

____ Permit Shield

For all applicable requirements listed above, provide monitoring/testing/recordkeeping/reporting which shall be used to demonstrate compliance. If the method is based on a permit or rule, include the condition number or citation. (Note: Each requirement listed above must have an associated method of demonstrating compliance. If there is not already a required method in place, then a method must be proposed.)

From current Title V permit:

Are you in compliance with all applicable requirements for this emission unit? Yes No

If no, complete the **Schedule of Compliance Form** as ATTACHMENT F.

ATTACHMENT E - Emission Unit Form

Emission Unit Description: <i>Storage Tank</i>			
Emission unit ID number: 9565	Emission unit name: Tank 9565	List any control devices associated with this emission unit: N/A	
Provide a description of the emission unit (type, method of operation, design parameters, etc.): Storage tank.			
Manufacturer:	Model number:	Serial number:	
Construction date: See Attachment D Equipment Table	Installation date: See Attachment D Equipment Table	Modification date(s): See Attachment D Equipment Table	
Design Capacity (examples: furnaces - tons/hr, tanks - gallons): See Attachment D Equipment Table			
Maximum Hourly Throughput:	Maximum Annual Throughput:	Maximum Operating Schedule: 24 hrs/day, 365 days/yr	
Fuel Usage Data (fill out all applicable fields)			
Does this emission unit combust fuel? ___Yes ___X___ No		If yes, is it? ___ Indirect Fired ___ Direct Fired	
Maximum design heat input and/or maximum horsepower rating:		Type and Btu/hr rating of burners:	
List the primary fuel type(s) and if applicable, the secondary fuel type(s). For each fuel type listed, provide the maximum hourly and annual fuel usage for each.			
Describe each fuel expected to be used during the term of the permit.			
Fuel Type	Max. Sulfur Content	Max. Ash Content	BTU Value

<i>Emissions Data</i>		
Criteria Pollutants	Potential Emissions	
	PPH	TPY
Carbon Monoxide (CO)		
Nitrogen Oxides (NO _x)		
Lead (Pb)		
Particulate Matter (PM _{2.5})		
Particulate Matter (PM ₁₀)		
Total Particulate Matter (TSP)		
Sulfur Dioxide (SO ₂)		
Volatile Organic Compounds (VOC)		
Hazardous Air Pollutants	Potential Emissions	
	PPH	TPY
Regulated Pollutants other than Criteria and HAP	Potential Emissions	
	PPH	TPY

List the method(s) used to calculate the potential emissions (include dates of any stack tests conducted, versions of software used, source and dates of emission factors, etc.).

Applicable Requirements

List all applicable requirements for this emission unit. For each applicable requirement, include the underlying rule/regulation citation and/or construction permit with the condition number. (Note: Title V permit condition numbers alone are not the underlying applicable requirements). If an emission limit is calculated based on the type of source and design capacity or if a standard is based on a design parameter, this information should also be included.

From current Title V permit:

____ Permit Shield

For all applicable requirements listed above, provide monitoring/testing/recordkeeping/reporting which shall be used to demonstrate compliance. If the method is based on a permit or rule, include the condition number or citation. (Note: Each requirement listed above must have an associated method of demonstrating compliance. If there is not already a required method in place, then a method must be proposed.)

From current Title V permit:

Are you in compliance with all applicable requirements for this emission unit? Yes No

If no, complete the **Schedule of Compliance Form** as ATTACHMENT F.

ATTACHMENT E - Emission Unit Form

Emission Unit Description: *Storage Tank*

Emission unit ID number: 9566	Emission unit name: Tank 9566	List any control devices associated with this emission unit: N/A
---	---	--

Provide a description of the emission unit (type, method of operation, design parameters, etc.):
Storage tank.

Manufacturer:	Model number:	Serial number:
----------------------	----------------------	-----------------------

Construction date: See Attachment D Equipment Table	Installation date: See Attachment D Equipment Table	Modification date(s): See Attachment D Equipment Table
---	---	--

Design Capacity (examples: furnaces - tons/hr, tanks - gallons): See Attachment D Equipment Table

Maximum Hourly Throughput:	Maximum Annual Throughput:	Maximum Operating Schedule: 24 hrs/day, 365 days/yr
-----------------------------------	-----------------------------------	---

Fuel Usage Data (fill out all applicable fields)

Does this emission unit combust fuel? ___Yes ___X___ No	If yes, is it? ___ Indirect Fired ___ Direct Fired
--	--

Maximum design heat input and/or maximum horsepower rating:	Type and Btu/hr rating of burners:
--	---

List the primary fuel type(s) and if applicable, the secondary fuel type(s). For each fuel type listed, provide the maximum hourly and annual fuel usage for each.

Describe each fuel expected to be used during the term of the permit.

Fuel Type	Max. Sulfur Content	Max. Ash Content	BTU Value

<i>Emissions Data</i>		
Criteria Pollutants	Potential Emissions	
	PPH	TPY
Carbon Monoxide (CO)		
Nitrogen Oxides (NO _x)		
Lead (Pb)		
Particulate Matter (PM _{2.5})		
Particulate Matter (PM ₁₀)		
Total Particulate Matter (TSP)		
Sulfur Dioxide (SO ₂)		
Volatile Organic Compounds (VOC)		
Hazardous Air Pollutants	Potential Emissions	
	PPH	TPY
Regulated Pollutants other than Criteria and HAP	Potential Emissions	
	PPH	TPY

List the method(s) used to calculate the potential emissions (include dates of any stack tests conducted, versions of software used, source and dates of emission factors, etc.).

Applicable Requirements

List all applicable requirements for this emission unit. For each applicable requirement, include the underlying rule/regulation citation and/or construction permit with the condition number. (Note: Title V permit condition numbers alone are not the underlying applicable requirements). If an emission limit is calculated based on the type of source and design capacity or if a standard is based on a design parameter, this information should also be included.

From current Title V permit:

____ Permit Shield

For all applicable requirements listed above, provide monitoring/testing/recordkeeping/reporting which shall be used to demonstrate compliance. If the method is based on a permit or rule, include the condition number or citation. (Note: Each requirement listed above must have an associated method of demonstrating compliance. If there is not already a required method in place, then a method must be proposed.)

From current Title V permit:

Are you in compliance with all applicable requirements for this emission unit? Yes No

If no, complete the **Schedule of Compliance Form** as ATTACHMENT F.

ATTACHMENT E - Emission Unit Form

Emission Unit Description: *Storage Tank*

Emission unit ID number: 9567	Emission unit name: Tank 9567	List any control devices associated with this emission unit: N/A
---	---	--

Provide a description of the emission unit (type, method of operation, design parameters, etc.):
Storage tank.

Manufacturer:	Model number:	Serial number:
----------------------	----------------------	-----------------------

Construction date: See Attachment D Equipment Table	Installation date: See Attachment D Equipment Table	Modification date(s): See Attachment D Equipment Table
---	---	--

Design Capacity (examples: furnaces - tons/hr, tanks - gallons): See Attachment D Equipment Table

Maximum Hourly Throughput:	Maximum Annual Throughput:	Maximum Operating Schedule: 24 hrs/day, 365 days/yr
-----------------------------------	-----------------------------------	---

Fuel Usage Data (fill out all applicable fields)

Does this emission unit combust fuel? <input type="checkbox"/> Yes <input checked="" type="checkbox"/> No	If yes, is it? <input type="checkbox"/> Indirect Fired <input type="checkbox"/> Direct Fired
--	--

Maximum design heat input and/or maximum horsepower rating:	Type and Btu/hr rating of burners:
--	---

List the primary fuel type(s) and if applicable, the secondary fuel type(s). For each fuel type listed, provide the maximum hourly and annual fuel usage for each.

Describe each fuel expected to be used during the term of the permit.

Fuel Type	Max. Sulfur Content	Max. Ash Content	BTU Value

<i>Emissions Data</i>		
Criteria Pollutants	Potential Emissions	
	PPH	TPY
Carbon Monoxide (CO)		
Nitrogen Oxides (NO _x)		
Lead (Pb)		
Particulate Matter (PM _{2.5})		
Particulate Matter (PM ₁₀)		
Total Particulate Matter (TSP)		
Sulfur Dioxide (SO ₂)		
Volatile Organic Compounds (VOC)		
Hazardous Air Pollutants	Potential Emissions	
	PPH	TPY
Regulated Pollutants other than Criteria and HAP	Potential Emissions	
	PPH	TPY

List the method(s) used to calculate the potential emissions (include dates of any stack tests conducted, versions of software used, source and dates of emission factors, etc.).

Applicable Requirements

List all applicable requirements for this emission unit. For each applicable requirement, include the underlying rule/regulation citation and/or construction permit with the condition number. (Note: Title V permit condition numbers alone are not the underlying applicable requirements). If an emission limit is calculated based on the type of source and design capacity or if a standard is based on a design parameter, this information should also be included.

From current Title V permit:

____ Permit Shield

For all applicable requirements listed above, provide monitoring/testing/recordkeeping/reporting which shall be used to demonstrate compliance. If the method is based on a permit or rule, include the condition number or citation. (Note: Each requirement listed above must have an associated method of demonstrating compliance. If there is not already a required method in place, then a method must be proposed.)

From current Title V permit:

Are you in compliance with all applicable requirements for this emission unit? Yes No

If no, complete the **Schedule of Compliance Form** as ATTACHMENT F.

ATTACHMENT E - Emission Unit Form

Emission Unit Description: <i>Storage Tank</i>			
Emission unit ID number: 9568	Emission unit name: Tank 9568	List any control devices associated with this emission unit: N/A	
Provide a description of the emission unit (type, method of operation, design parameters, etc.): Storage tank.			
Manufacturer:	Model number:	Serial number:	
Construction date: See Attachment D Equipment Table	Installation date: See Attachment D Equipment Table	Modification date(s): See Attachment D Equipment Table	
Design Capacity (examples: furnaces - tons/hr, tanks - gallons): See Attachment D Equipment Table			
Maximum Hourly Throughput:	Maximum Annual Throughput:	Maximum Operating Schedule: 24 hrs/day, 365 days/yr	
Fuel Usage Data (fill out all applicable fields)			
Does this emission unit combust fuel? ___Yes ___X___ No		If yes, is it? ___ Indirect Fired ___ Direct Fired	
Maximum design heat input and/or maximum horsepower rating:		Type and Btu/hr rating of burners:	
List the primary fuel type(s) and if applicable, the secondary fuel type(s). For each fuel type listed, provide the maximum hourly and annual fuel usage for each.			
Describe each fuel expected to be used during the term of the permit.			
Fuel Type	Max. Sulfur Content	Max. Ash Content	BTU Value

<i>Emissions Data</i>		
Criteria Pollutants	Potential Emissions	
	PPH	TPY
Carbon Monoxide (CO)		
Nitrogen Oxides (NO _x)		
Lead (Pb)		
Particulate Matter (PM _{2.5})		
Particulate Matter (PM ₁₀)		
Total Particulate Matter (TSP)		
Sulfur Dioxide (SO ₂)		
Volatile Organic Compounds (VOC)		
Hazardous Air Pollutants	Potential Emissions	
	PPH	TPY
Regulated Pollutants other than Criteria and HAP	Potential Emissions	
	PPH	TPY

List the method(s) used to calculate the potential emissions (include dates of any stack tests conducted, versions of software used, source and dates of emission factors, etc.).

Applicable Requirements

List all applicable requirements for this emission unit. For each applicable requirement, include the underlying rule/regulation citation and/or construction permit with the condition number. (Note: Title V permit condition numbers alone are not the underlying applicable requirements). If an emission limit is calculated based on the type of source and design capacity or if a standard is based on a design parameter, this information should also be included.

From current Title V permit:

____ Permit Shield

For all applicable requirements listed above, provide monitoring/testing/recordkeeping/reporting which shall be used to demonstrate compliance. If the method is based on a permit or rule, include the condition number or citation. (Note: Each requirement listed above must have an associated method of demonstrating compliance. If there is not already a required method in place, then a method must be proposed.)

From current Title V permit:

Are you in compliance with all applicable requirements for this emission unit? Yes No

If no, complete the **Schedule of Compliance Form** as ATTACHMENT F.

ATTACHMENT E - Emission Unit Form

Emission Unit Description: <i>Storage Tank</i>			
Emission unit ID number: 9569	Emission unit name: Tank 9569	List any control devices associated with this emission unit: N/A	
Provide a description of the emission unit (type, method of operation, design parameters, etc.): Storage tank.			
Manufacturer:	Model number:	Serial number:	
Construction date: See Attachment D Equipment Table	Installation date: See Attachment D Equipment Table	Modification date(s): See Attachment D Equipment Table	
Design Capacity (examples: furnaces - tons/hr, tanks - gallons): See Attachment D Equipment Table			
Maximum Hourly Throughput:	Maximum Annual Throughput:	Maximum Operating Schedule: 24 hrs/day, 365 days/yr	
Fuel Usage Data (fill out all applicable fields)			
Does this emission unit combust fuel? <input type="checkbox"/> Yes <input checked="" type="checkbox"/> No		If yes, is it? <input type="checkbox"/> Indirect Fired <input type="checkbox"/> Direct Fired	
Maximum design heat input and/or maximum horsepower rating:		Type and Btu/hr rating of burners:	
List the primary fuel type(s) and if applicable, the secondary fuel type(s). For each fuel type listed, provide the maximum hourly and annual fuel usage for each.			
Describe each fuel expected to be used during the term of the permit.			
Fuel Type	Max. Sulfur Content	Max. Ash Content	BTU Value

<i>Emissions Data</i>		
Criteria Pollutants	Potential Emissions	
	PPH	TPY
Carbon Monoxide (CO)		
Nitrogen Oxides (NO _x)		
Lead (Pb)		
Particulate Matter (PM _{2.5})		
Particulate Matter (PM ₁₀)		
Total Particulate Matter (TSP)		
Sulfur Dioxide (SO ₂)		
Volatile Organic Compounds (VOC)		
Hazardous Air Pollutants	Potential Emissions	
	PPH	TPY
Regulated Pollutants other than Criteria and HAP	Potential Emissions	
	PPH	TPY

List the method(s) used to calculate the potential emissions (include dates of any stack tests conducted, versions of software used, source and dates of emission factors, etc.).

Applicable Requirements

List all applicable requirements for this emission unit. For each applicable requirement, include the underlying rule/regulation citation and/or construction permit with the condition number. (Note: Title V permit condition numbers alone are not the underlying applicable requirements). If an emission limit is calculated based on the type of source and design capacity or if a standard is based on a design parameter, this information should also be included.

From current Title V permit:

____ Permit Shield

For all applicable requirements listed above, provide monitoring/testing/recordkeeping/reporting which shall be used to demonstrate compliance. If the method is based on a permit or rule, include the condition number or citation. (Note: Each requirement listed above must have an associated method of demonstrating compliance. If there is not already a required method in place, then a method must be proposed.)

From current Title V permit:

Are you in compliance with all applicable requirements for this emission unit? Yes No

If no, complete the **Schedule of Compliance Form** as ATTACHMENT F.

ATTACHMENT E - Emission Unit Form

Emission Unit Description: *Storage Tank*

Emission unit ID number: 9611	Emission unit name: Tank 9611	List any control devices associated with this emission unit: N/A
---	---	--

Provide a description of the emission unit (type, method of operation, design parameters, etc.):
Storage tank.

Manufacturer:	Model number:	Serial number:
----------------------	----------------------	-----------------------

Construction date: See Attachment D Equipment Table	Installation date: See Attachment D Equipment Table	Modification date(s): See Attachment D Equipment Table
---	---	--

Design Capacity (examples: furnaces - tons/hr, tanks - gallons): See Attachment D Equipment Table

Maximum Hourly Throughput:	Maximum Annual Throughput:	Maximum Operating Schedule: 24 hrs/day, 365 days/yr
-----------------------------------	-----------------------------------	---

Fuel Usage Data (fill out all applicable fields)

Does this emission unit combust fuel? ___Yes ___X___ No	If yes, is it? ___ Indirect Fired ___ Direct Fired
--	--

Maximum design heat input and/or maximum horsepower rating:	Type and Btu/hr rating of burners:
--	---

List the primary fuel type(s) and if applicable, the secondary fuel type(s). For each fuel type listed, provide the maximum hourly and annual fuel usage for each.

Describe each fuel expected to be used during the term of the permit.

Fuel Type	Max. Sulfur Content	Max. Ash Content	BTU Value

<i>Emissions Data</i>		
Criteria Pollutants	Potential Emissions	
	PPH	TPY
Carbon Monoxide (CO)		
Nitrogen Oxides (NO _x)		
Lead (Pb)		
Particulate Matter (PM _{2.5})		
Particulate Matter (PM ₁₀)		
Total Particulate Matter (TSP)		
Sulfur Dioxide (SO ₂)		
Volatile Organic Compounds (VOC)		
Hazardous Air Pollutants	Potential Emissions	
	PPH	TPY
Regulated Pollutants other than Criteria and HAP	Potential Emissions	
	PPH	TPY

List the method(s) used to calculate the potential emissions (include dates of any stack tests conducted, versions of software used, source and dates of emission factors, etc.).

Applicable Requirements

List all applicable requirements for this emission unit. For each applicable requirement, include the underlying rule/regulation citation and/or construction permit with the condition number. (Note: Title V permit condition numbers alone are not the underlying applicable requirements). If an emission limit is calculated based on the type of source and design capacity or if a standard is based on a design parameter, this information should also be included.

From current Title V permit:

____ Permit Shield

For all applicable requirements listed above, provide monitoring/testing/recordkeeping/reporting which shall be used to demonstrate compliance. If the method is based on a permit or rule, include the condition number or citation. (Note: Each requirement listed above must have an associated method of demonstrating compliance. If there is not already a required method in place, then a method must be proposed.)

From current Title V permit:

Are you in compliance with all applicable requirements for this emission unit? Yes No

If no, complete the **Schedule of Compliance Form** as ATTACHMENT F.

ATTACHMENT E - Emission Unit Form

Emission Unit Description: <i>Storage Tank</i>			
Emission unit ID number: 9612	Emission unit name: Tank 9612	List any control devices associated with this emission unit: N/A	
Provide a description of the emission unit (type, method of operation, design parameters, etc.): Storage tank.			
Manufacturer:	Model number:	Serial number:	
Construction date: See Attachment D Equipment Table	Installation date: See Attachment D Equipment Table	Modification date(s): See Attachment D Equipment Table	
Design Capacity (examples: furnaces - tons/hr, tanks - gallons): See Attachment D Equipment Table			
Maximum Hourly Throughput:	Maximum Annual Throughput:	Maximum Operating Schedule: 24 hrs/day, 365 days/yr	
Fuel Usage Data (fill out all applicable fields)			
Does this emission unit combust fuel? <input type="checkbox"/> Yes <input checked="" type="checkbox"/> No		If yes, is it? <input type="checkbox"/> Indirect Fired <input type="checkbox"/> Direct Fired	
Maximum design heat input and/or maximum horsepower rating:		Type and Btu/hr rating of burners:	
List the primary fuel type(s) and if applicable, the secondary fuel type(s). For each fuel type listed, provide the maximum hourly and annual fuel usage for each.			
Describe each fuel expected to be used during the term of the permit.			
Fuel Type	Max. Sulfur Content	Max. Ash Content	BTU Value

<i>Emissions Data</i>		
Criteria Pollutants	Potential Emissions	
	PPH	TPY
Carbon Monoxide (CO)		
Nitrogen Oxides (NO _x)		
Lead (Pb)		
Particulate Matter (PM _{2.5})		
Particulate Matter (PM ₁₀)		
Total Particulate Matter (TSP)		
Sulfur Dioxide (SO ₂)		
Volatile Organic Compounds (VOC)		
Hazardous Air Pollutants	Potential Emissions	
	PPH	TPY
Regulated Pollutants other than Criteria and HAP	Potential Emissions	
	PPH	TPY

List the method(s) used to calculate the potential emissions (include dates of any stack tests conducted, versions of software used, source and dates of emission factors, etc.).

Applicable Requirements

List all applicable requirements for this emission unit. For each applicable requirement, include the underlying rule/regulation citation and/or construction permit with the condition number. (Note: Title V permit condition numbers alone are not the underlying applicable requirements). If an emission limit is calculated based on the type of source and design capacity or if a standard is based on a design parameter, this information should also be included.

From current Title V permit:

____ Permit Shield

For all applicable requirements listed above, provide monitoring/testing/recordkeeping/reporting which shall be used to demonstrate compliance. If the method is based on a permit or rule, include the condition number or citation. (Note: Each requirement listed above must have an associated method of demonstrating compliance. If there is not already a required method in place, then a method must be proposed.)

From current Title V permit:

Are you in compliance with all applicable requirements for this emission unit? Yes No

If no, complete the **Schedule of Compliance Form** as ATTACHMENT F.

ATTACHMENT E - Emission Unit Form

Emission Unit Description: *Storage Tank*

Emission unit ID number: 9613	Emission unit name: Tank 9613	List any control devices associated with this emission unit: N/A
---	---	--

Provide a description of the emission unit (type, method of operation, design parameters, etc.):
Storage tank.

Manufacturer:	Model number:	Serial number:
----------------------	----------------------	-----------------------

Construction date: See Attachment D Equipment Table	Installation date: See Attachment D Equipment Table	Modification date(s): See Attachment D Equipment Table
---	---	--

Design Capacity (examples: furnaces - tons/hr, tanks - gallons): See Attachment D Equipment Table

Maximum Hourly Throughput:	Maximum Annual Throughput:	Maximum Operating Schedule: 24 hrs/day, 365 days/yr
-----------------------------------	-----------------------------------	---

Fuel Usage Data (fill out all applicable fields)

Does this emission unit combust fuel? <input type="checkbox"/> Yes <input checked="" type="checkbox"/> No	If yes, is it? <input type="checkbox"/> Indirect Fired <input type="checkbox"/> Direct Fired
--	--

Maximum design heat input and/or maximum horsepower rating:	Type and Btu/hr rating of burners:
--	---

List the primary fuel type(s) and if applicable, the secondary fuel type(s). For each fuel type listed, provide the maximum hourly and annual fuel usage for each.

Describe each fuel expected to be used during the term of the permit.

Fuel Type	Max. Sulfur Content	Max. Ash Content	BTU Value

<i>Emissions Data</i>		
Criteria Pollutants	Potential Emissions	
	PPH	TPY
Carbon Monoxide (CO)		
Nitrogen Oxides (NO _x)		
Lead (Pb)		
Particulate Matter (PM _{2.5})		
Particulate Matter (PM ₁₀)		
Total Particulate Matter (TSP)		
Sulfur Dioxide (SO ₂)		
Volatile Organic Compounds (VOC)		
Hazardous Air Pollutants	Potential Emissions	
	PPH	TPY
Regulated Pollutants other than Criteria and HAP	Potential Emissions	
	PPH	TPY

List the method(s) used to calculate the potential emissions (include dates of any stack tests conducted, versions of software used, source and dates of emission factors, etc.).

Applicable Requirements

List all applicable requirements for this emission unit. For each applicable requirement, include the underlying rule/regulation citation and/or construction permit with the condition number. (Note: Title V permit condition numbers alone are not the underlying applicable requirements). If an emission limit is calculated based on the type of source and design capacity or if a standard is based on a design parameter, this information should also be included.

From current Title V permit:

____ Permit Shield

For all applicable requirements listed above, provide monitoring/testing/recordkeeping/reporting which shall be used to demonstrate compliance. If the method is based on a permit or rule, include the condition number or citation. (Note: Each requirement listed above must have an associated method of demonstrating compliance. If there is not already a required method in place, then a method must be proposed.)

From current Title V permit:

Are you in compliance with all applicable requirements for this emission unit? Yes No

If no, complete the **Schedule of Compliance Form** as ATTACHMENT F.

ATTACHMENT E - Emission Unit Form

Emission Unit Description: <i>Storage Tank</i>			
Emission unit ID number: 9614	Emission unit name: Tank 9614	List any control devices associated with this emission unit: N/A	
Provide a description of the emission unit (type, method of operation, design parameters, etc.): Storage tank.			
Manufacturer:	Model number:	Serial number:	
Construction date: See Attachment D Equipment Table	Installation date: See Attachment D Equipment Table	Modification date(s): See Attachment D Equipment Table	
Design Capacity (examples: furnaces - tons/hr, tanks - gallons): See Attachment D Equipment Table			
Maximum Hourly Throughput:	Maximum Annual Throughput:	Maximum Operating Schedule: 24 hrs/day, 365 days/yr	
Fuel Usage Data (fill out all applicable fields)			
Does this emission unit combust fuel? ___Yes ___X___ No		If yes, is it? ___ Indirect Fired ___ Direct Fired	
Maximum design heat input and/or maximum horsepower rating:		Type and Btu/hr rating of burners:	
List the primary fuel type(s) and if applicable, the secondary fuel type(s). For each fuel type listed, provide the maximum hourly and annual fuel usage for each.			
Describe each fuel expected to be used during the term of the permit.			
Fuel Type	Max. Sulfur Content	Max. Ash Content	BTU Value

<i>Emissions Data</i>		
Criteria Pollutants	Potential Emissions	
	PPH	TPY
Carbon Monoxide (CO)		
Nitrogen Oxides (NO _x)		
Lead (Pb)		
Particulate Matter (PM _{2.5})		
Particulate Matter (PM ₁₀)		
Total Particulate Matter (TSP)		
Sulfur Dioxide (SO ₂)		
Volatile Organic Compounds (VOC)		
Hazardous Air Pollutants	Potential Emissions	
	PPH	TPY
Regulated Pollutants other than Criteria and HAP	Potential Emissions	
	PPH	TPY

List the method(s) used to calculate the potential emissions (include dates of any stack tests conducted, versions of software used, source and dates of emission factors, etc.).

Applicable Requirements

List all applicable requirements for this emission unit. For each applicable requirement, include the underlying rule/regulation citation and/or construction permit with the condition number. (Note: Title V permit condition numbers alone are not the underlying applicable requirements). If an emission limit is calculated based on the type of source and design capacity or if a standard is based on a design parameter, this information should also be included.

From current Title V permit:

____ Permit Shield

For all applicable requirements listed above, provide monitoring/testing/recordkeeping/reporting which shall be used to demonstrate compliance. If the method is based on a permit or rule, include the condition number or citation. (Note: Each requirement listed above must have an associated method of demonstrating compliance. If there is not already a required method in place, then a method must be proposed.)

From current Title V permit:

Are you in compliance with all applicable requirements for this emission unit? Yes No

If no, complete the **Schedule of Compliance Form** as ATTACHMENT F.

ATTACHMENT E - Emission Unit Form

Emission Unit Description: *Storage Tank*

Emission unit ID number: 9615	Emission unit name: Tank 9615	List any control devices associated with this emission unit: N/A
---	---	--

Provide a description of the emission unit (type, method of operation, design parameters, etc.):
Storage tank.

Manufacturer:	Model number:	Serial number:
----------------------	----------------------	-----------------------

Construction date: See Attachment D Equipment Table	Installation date: See Attachment D Equipment Table	Modification date(s): See Attachment D Equipment Table
---	---	--

Design Capacity (examples: furnaces - tons/hr, tanks - gallons): See Attachment D Equipment Table

Maximum Hourly Throughput:	Maximum Annual Throughput:	Maximum Operating Schedule: 24 hrs/day, 365 days/yr
-----------------------------------	-----------------------------------	---

Fuel Usage Data (fill out all applicable fields)

Does this emission unit combust fuel? ___Yes ___X___ No	If yes, is it? ___ Indirect Fired ___ Direct Fired
--	--

Maximum design heat input and/or maximum horsepower rating:	Type and Btu/hr rating of burners:
--	---

List the primary fuel type(s) and if applicable, the secondary fuel type(s). For each fuel type listed, provide the maximum hourly and annual fuel usage for each.

Describe each fuel expected to be used during the term of the permit.

Fuel Type	Max. Sulfur Content	Max. Ash Content	BTU Value

<i>Emissions Data</i>		
Criteria Pollutants	Potential Emissions	
	PPH	TPY
Carbon Monoxide (CO)		
Nitrogen Oxides (NO _x)		
Lead (Pb)		
Particulate Matter (PM _{2.5})		
Particulate Matter (PM ₁₀)		
Total Particulate Matter (TSP)		
Sulfur Dioxide (SO ₂)		
Volatile Organic Compounds (VOC)		
Hazardous Air Pollutants	Potential Emissions	
	PPH	TPY
Regulated Pollutants other than Criteria and HAP	Potential Emissions	
	PPH	TPY

List the method(s) used to calculate the potential emissions (include dates of any stack tests conducted, versions of software used, source and dates of emission factors, etc.).

Applicable Requirements

List all applicable requirements for this emission unit. For each applicable requirement, include the underlying rule/regulation citation and/or construction permit with the condition number. (Note: Title V permit condition numbers alone are not the underlying applicable requirements). If an emission limit is calculated based on the type of source and design capacity or if a standard is based on a design parameter, this information should also be included.

From current Title V permit:

____ Permit Shield

For all applicable requirements listed above, provide monitoring/testing/recordkeeping/reporting which shall be used to demonstrate compliance. If the method is based on a permit or rule, include the condition number or citation. (Note: Each requirement listed above must have an associated method of demonstrating compliance. If there is not already a required method in place, then a method must be proposed.)

From current Title V permit:

Are you in compliance with all applicable requirements for this emission unit? Yes No

If no, complete the **Schedule of Compliance Form** as ATTACHMENT F.

ATTACHMENT E - Emission Unit Form

Emission Unit Description: *Storage Tank*

Emission unit ID number: 9616	Emission unit name: Tank 9616	List any control devices associated with this emission unit: N/A
---	---	--

Provide a description of the emission unit (type, method of operation, design parameters, etc.):
Storage tank.

Manufacturer:	Model number:	Serial number:
----------------------	----------------------	-----------------------

Construction date: See Attachment D Equipment Table	Installation date: See Attachment D Equipment Table	Modification date(s): See Attachment D Equipment Table
---	---	--

Design Capacity (examples: furnaces - tons/hr, tanks - gallons): See Attachment D Equipment Table

Maximum Hourly Throughput:	Maximum Annual Throughput:	Maximum Operating Schedule: 24 hrs/day, 365 days/yr
-----------------------------------	-----------------------------------	---

Fuel Usage Data (fill out all applicable fields)

Does this emission unit combust fuel? ___Yes ___X___ No	If yes, is it? ___ Indirect Fired ___ Direct Fired
--	--

Maximum design heat input and/or maximum horsepower rating:	Type and Btu/hr rating of burners:
--	---

List the primary fuel type(s) and if applicable, the secondary fuel type(s). For each fuel type listed, provide the maximum hourly and annual fuel usage for each.

Describe each fuel expected to be used during the term of the permit.

Fuel Type	Max. Sulfur Content	Max. Ash Content	BTU Value

<i>Emissions Data</i>		
Criteria Pollutants	Potential Emissions	
	PPH	TPY
Carbon Monoxide (CO)		
Nitrogen Oxides (NO _x)		
Lead (Pb)		
Particulate Matter (PM _{2.5})		
Particulate Matter (PM ₁₀)		
Total Particulate Matter (TSP)		
Sulfur Dioxide (SO ₂)		
Volatile Organic Compounds (VOC)		
Hazardous Air Pollutants	Potential Emissions	
	PPH	TPY
Regulated Pollutants other than Criteria and HAP	Potential Emissions	
	PPH	TPY

List the method(s) used to calculate the potential emissions (include dates of any stack tests conducted, versions of software used, source and dates of emission factors, etc.).

Applicable Requirements

List all applicable requirements for this emission unit. For each applicable requirement, include the underlying rule/regulation citation and/or construction permit with the condition number. (Note: Title V permit condition numbers alone are not the underlying applicable requirements). If an emission limit is calculated based on the type of source and design capacity or if a standard is based on a design parameter, this information should also be included.

From current Title V permit:

____ Permit Shield

For all applicable requirements listed above, provide monitoring/testing/recordkeeping/reporting which shall be used to demonstrate compliance. If the method is based on a permit or rule, include the condition number or citation. (Note: Each requirement listed above must have an associated method of demonstrating compliance. If there is not already a required method in place, then a method must be proposed.)

From current Title V permit:

Are you in compliance with all applicable requirements for this emission unit? Yes No

If no, complete the **Schedule of Compliance Form** as ATTACHMENT F.

ATTACHMENT E - Emission Unit Form

Emission Unit Description: <i>Storage Tank</i>			
Emission unit ID number: 9617	Emission unit name: Tank 9617	List any control devices associated with this emission unit: N/A	
Provide a description of the emission unit (type, method of operation, design parameters, etc.): Storage tank.			
Manufacturer:	Model number:	Serial number:	
Construction date: See Attachment D Equipment Table	Installation date: See Attachment D Equipment Table	Modification date(s): See Attachment D Equipment Table	
Design Capacity (examples: furnaces - tons/hr, tanks - gallons): See Attachment D Equipment Table			
Maximum Hourly Throughput:	Maximum Annual Throughput:	Maximum Operating Schedule: 24 hrs/day, 365 days/yr	
Fuel Usage Data (fill out all applicable fields)			
Does this emission unit combust fuel? ___Yes ___X___ No		If yes, is it? ___ Indirect Fired ___ Direct Fired	
Maximum design heat input and/or maximum horsepower rating:		Type and Btu/hr rating of burners:	
List the primary fuel type(s) and if applicable, the secondary fuel type(s). For each fuel type listed, provide the maximum hourly and annual fuel usage for each.			
Describe each fuel expected to be used during the term of the permit.			
Fuel Type	Max. Sulfur Content	Max. Ash Content	BTU Value

<i>Emissions Data</i>		
Criteria Pollutants	Potential Emissions	
	PPH	TPY
Carbon Monoxide (CO)		
Nitrogen Oxides (NO _x)		
Lead (Pb)		
Particulate Matter (PM _{2.5})		
Particulate Matter (PM ₁₀)		
Total Particulate Matter (TSP)		
Sulfur Dioxide (SO ₂)		
Volatile Organic Compounds (VOC)		
Hazardous Air Pollutants	Potential Emissions	
	PPH	TPY
Regulated Pollutants other than Criteria and HAP	Potential Emissions	
	PPH	TPY

List the method(s) used to calculate the potential emissions (include dates of any stack tests conducted, versions of software used, source and dates of emission factors, etc.).

Applicable Requirements

List all applicable requirements for this emission unit. For each applicable requirement, include the underlying rule/regulation citation and/or construction permit with the condition number. (Note: Title V permit condition numbers alone are not the underlying applicable requirements). If an emission limit is calculated based on the type of source and design capacity or if a standard is based on a design parameter, this information should also be included.

From current Title V permit:

____ Permit Shield

For all applicable requirements listed above, provide monitoring/testing/recordkeeping/reporting which shall be used to demonstrate compliance. If the method is based on a permit or rule, include the condition number or citation. (Note: Each requirement listed above must have an associated method of demonstrating compliance. If there is not already a required method in place, then a method must be proposed.)

From current Title V permit:

Are you in compliance with all applicable requirements for this emission unit? Yes No

If no, complete the **Schedule of Compliance Form** as ATTACHMENT F.

ATTACHMENT E - Emission Unit Form

Emission Unit Description: *Storage Tank*

Emission unit ID number: 9619	Emission unit name: Tank 9619	List any control devices associated with this emission unit: N/A
---	---	--

Provide a description of the emission unit (type, method of operation, design parameters, etc.):
Storage tank.

Manufacturer:	Model number:	Serial number:
----------------------	----------------------	-----------------------

Construction date: See Attachment D Equipment Table	Installation date: See Attachment D Equipment Table	Modification date(s): See Attachment D Equipment Table
---	---	--

Design Capacity (examples: furnaces - tons/hr, tanks - gallons): See Attachment D Equipment Table

Maximum Hourly Throughput:	Maximum Annual Throughput:	Maximum Operating Schedule: 24 hrs/day, 365 days/yr
-----------------------------------	-----------------------------------	---

Fuel Usage Data (fill out all applicable fields)

Does this emission unit combust fuel? ___Yes ___X___ No	If yes, is it? ___ Indirect Fired ___ Direct Fired
--	--

Maximum design heat input and/or maximum horsepower rating:	Type and Btu/hr rating of burners:
--	---

List the primary fuel type(s) and if applicable, the secondary fuel type(s). For each fuel type listed, provide the maximum hourly and annual fuel usage for each.

Describe each fuel expected to be used during the term of the permit.

Fuel Type	Max. Sulfur Content	Max. Ash Content	BTU Value

<i>Emissions Data</i>		
Criteria Pollutants	Potential Emissions	
	PPH	TPY
Carbon Monoxide (CO)		
Nitrogen Oxides (NO _x)		
Lead (Pb)		
Particulate Matter (PM _{2.5})		
Particulate Matter (PM ₁₀)		
Total Particulate Matter (TSP)		
Sulfur Dioxide (SO ₂)		
Volatile Organic Compounds (VOC)		
Hazardous Air Pollutants	Potential Emissions	
	PPH	TPY
Regulated Pollutants other than Criteria and HAP	Potential Emissions	
	PPH	TPY

List the method(s) used to calculate the potential emissions (include dates of any stack tests conducted, versions of software used, source and dates of emission factors, etc.).

Applicable Requirements

List all applicable requirements for this emission unit. For each applicable requirement, include the underlying rule/regulation citation and/or construction permit with the condition number. (Note: Title V permit condition numbers alone are not the underlying applicable requirements). If an emission limit is calculated based on the type of source and design capacity or if a standard is based on a design parameter, this information should also be included.

From current Title V permit:

____ Permit Shield

For all applicable requirements listed above, provide monitoring/testing/recordkeeping/reporting which shall be used to demonstrate compliance. If the method is based on a permit or rule, include the condition number or citation. (Note: Each requirement listed above must have an associated method of demonstrating compliance. If there is not already a required method in place, then a method must be proposed.)

From current Title V permit:

Are you in compliance with all applicable requirements for this emission unit? Yes No

If no, complete the **Schedule of Compliance Form** as ATTACHMENT F.

ATTACHMENT E - Emission Unit Form

Emission Unit Description: *Storage Tank*

Emission unit ID number: 9621	Emission unit name: Tank 9621	List any control devices associated with this emission unit: N/A
---	---	--

Provide a description of the emission unit (type, method of operation, design parameters, etc.):
Storage tank.

Manufacturer:	Model number:	Serial number:
----------------------	----------------------	-----------------------

Construction date: See Attachment D Equipment Table	Installation date: See Attachment D Equipment Table	Modification date(s): See Attachment D Equipment Table
---	---	--

Design Capacity (examples: furnaces - tons/hr, tanks - gallons): See Attachment D Equipment Table

Maximum Hourly Throughput:	Maximum Annual Throughput:	Maximum Operating Schedule: 24 hrs/day, 365 days/yr
-----------------------------------	-----------------------------------	---

Fuel Usage Data (fill out all applicable fields)

Does this emission unit combust fuel? ___Yes ___X___ No	If yes, is it? ___ Indirect Fired ___ Direct Fired
--	--

Maximum design heat input and/or maximum horsepower rating:	Type and Btu/hr rating of burners:
--	---

List the primary fuel type(s) and if applicable, the secondary fuel type(s). For each fuel type listed, provide the maximum hourly and annual fuel usage for each.

Describe each fuel expected to be used during the term of the permit.

Fuel Type	Max. Sulfur Content	Max. Ash Content	BTU Value

<i>Emissions Data</i>		
Criteria Pollutants	Potential Emissions	
	PPH	TPY
Carbon Monoxide (CO)		
Nitrogen Oxides (NO _x)		
Lead (Pb)		
Particulate Matter (PM _{2.5})		
Particulate Matter (PM ₁₀)		
Total Particulate Matter (TSP)		
Sulfur Dioxide (SO ₂)		
Volatile Organic Compounds (VOC)		
Hazardous Air Pollutants	Potential Emissions	
	PPH	TPY
Regulated Pollutants other than Criteria and HAP	Potential Emissions	
	PPH	TPY

List the method(s) used to calculate the potential emissions (include dates of any stack tests conducted, versions of software used, source and dates of emission factors, etc.).

Applicable Requirements

List all applicable requirements for this emission unit. For each applicable requirement, include the underlying rule/regulation citation and/or construction permit with the condition number. (Note: Title V permit condition numbers alone are not the underlying applicable requirements). If an emission limit is calculated based on the type of source and design capacity or if a standard is based on a design parameter, this information should also be included.

From current Title V permit:

____ Permit Shield

For all applicable requirements listed above, provide monitoring/testing/recordkeeping/reporting which shall be used to demonstrate compliance. If the method is based on a permit or rule, include the condition number or citation. (Note: Each requirement listed above must have an associated method of demonstrating compliance. If there is not already a required method in place, then a method must be proposed.)

From current Title V permit:

Are you in compliance with all applicable requirements for this emission unit? Yes No

If no, complete the **Schedule of Compliance Form** as ATTACHMENT F.

ATTACHMENT E - Emission Unit Form

Emission Unit Description: <i>Storage Tank</i>			
Emission unit ID number: 9622	Emission unit name: Tank 9622	List any control devices associated with this emission unit: N/A	
Provide a description of the emission unit (type, method of operation, design parameters, etc.): Storage tank.			
Manufacturer:	Model number:	Serial number:	
Construction date: See Attachment D Equipment Table	Installation date: See Attachment D Equipment Table	Modification date(s): See Attachment D Equipment Table	
Design Capacity (examples: furnaces - tons/hr, tanks - gallons): See Attachment D Equipment Table			
Maximum Hourly Throughput:	Maximum Annual Throughput:	Maximum Operating Schedule: 24 hrs/day, 365 days/yr	
Fuel Usage Data (fill out all applicable fields)			
Does this emission unit combust fuel? ___Yes ___X___ No		If yes, is it? ___ Indirect Fired ___ Direct Fired	
Maximum design heat input and/or maximum horsepower rating:		Type and Btu/hr rating of burners:	
List the primary fuel type(s) and if applicable, the secondary fuel type(s). For each fuel type listed, provide the maximum hourly and annual fuel usage for each.			
Describe each fuel expected to be used during the term of the permit.			
Fuel Type	Max. Sulfur Content	Max. Ash Content	BTU Value

<i>Emissions Data</i>		
Criteria Pollutants	Potential Emissions	
	PPH	TPY
Carbon Monoxide (CO)		
Nitrogen Oxides (NO _x)		
Lead (Pb)		
Particulate Matter (PM _{2.5})		
Particulate Matter (PM ₁₀)		
Total Particulate Matter (TSP)		
Sulfur Dioxide (SO ₂)		
Volatile Organic Compounds (VOC)		
Hazardous Air Pollutants	Potential Emissions	
	PPH	TPY
Regulated Pollutants other than Criteria and HAP	Potential Emissions	
	PPH	TPY

List the method(s) used to calculate the potential emissions (include dates of any stack tests conducted, versions of software used, source and dates of emission factors, etc.).

Applicable Requirements

List all applicable requirements for this emission unit. For each applicable requirement, include the underlying rule/regulation citation and/or construction permit with the condition number. (Note: Title V permit condition numbers alone are not the underlying applicable requirements). If an emission limit is calculated based on the type of source and design capacity or if a standard is based on a design parameter, this information should also be included.

From current Title V permit:

____ Permit Shield

For all applicable requirements listed above, provide monitoring/testing/recordkeeping/reporting which shall be used to demonstrate compliance. If the method is based on a permit or rule, include the condition number or citation. (Note: Each requirement listed above must have an associated method of demonstrating compliance. If there is not already a required method in place, then a method must be proposed.)

From current Title V permit:

Are you in compliance with all applicable requirements for this emission unit? Yes No

If no, complete the **Schedule of Compliance Form** as ATTACHMENT F.

ATTACHMENT E - Emission Unit Form

Emission Unit Description: *Storage Tank*

Emission unit ID number: 9623	Emission unit name: Tank 9623	List any control devices associated with this emission unit: N/A
---	---	--

Provide a description of the emission unit (type, method of operation, design parameters, etc.):
Storage tank.

Manufacturer:	Model number:	Serial number:
----------------------	----------------------	-----------------------

Construction date: See Attachment D Equipment Table	Installation date: See Attachment D Equipment Table	Modification date(s): See Attachment D Equipment Table
---	---	--

Design Capacity (examples: furnaces - tons/hr, tanks - gallons): See Attachment D Equipment Table

Maximum Hourly Throughput:	Maximum Annual Throughput:	Maximum Operating Schedule: 24 hrs/day, 365 days/yr
-----------------------------------	-----------------------------------	---

Fuel Usage Data (fill out all applicable fields)

Does this emission unit combust fuel? ___Yes ___X___ No	If yes, is it? ___ Indirect Fired ___ Direct Fired
--	--

Maximum design heat input and/or maximum horsepower rating:	Type and Btu/hr rating of burners:
--	---

List the primary fuel type(s) and if applicable, the secondary fuel type(s). For each fuel type listed, provide the maximum hourly and annual fuel usage for each.

Describe each fuel expected to be used during the term of the permit.

Fuel Type	Max. Sulfur Content	Max. Ash Content	BTU Value

<i>Emissions Data</i>		
Criteria Pollutants	Potential Emissions	
	PPH	TPY
Carbon Monoxide (CO)		
Nitrogen Oxides (NO _x)		
Lead (Pb)		
Particulate Matter (PM _{2.5})		
Particulate Matter (PM ₁₀)		
Total Particulate Matter (TSP)		
Sulfur Dioxide (SO ₂)		
Volatile Organic Compounds (VOC)		
Hazardous Air Pollutants	Potential Emissions	
	PPH	TPY
Regulated Pollutants other than Criteria and HAP	Potential Emissions	
	PPH	TPY

List the method(s) used to calculate the potential emissions (include dates of any stack tests conducted, versions of software used, source and dates of emission factors, etc.).

Applicable Requirements

List all applicable requirements for this emission unit. For each applicable requirement, include the underlying rule/regulation citation and/or construction permit with the condition number. (Note: Title V permit condition numbers alone are not the underlying applicable requirements). If an emission limit is calculated based on the type of source and design capacity or if a standard is based on a design parameter, this information should also be included.

From current Title V permit:

____ Permit Shield

For all applicable requirements listed above, provide monitoring/testing/recordkeeping/reporting which shall be used to demonstrate compliance. If the method is based on a permit or rule, include the condition number or citation. (Note: Each requirement listed above must have an associated method of demonstrating compliance. If there is not already a required method in place, then a method must be proposed.)

From current Title V permit:

Are you in compliance with all applicable requirements for this emission unit? Yes No

If no, complete the **Schedule of Compliance Form** as ATTACHMENT F.

ATTACHMENT E - Emission Unit Form

Emission Unit Description: *Storage Tank*

Emission unit ID number: 9624	Emission unit name: Tank 9624	List any control devices associated with this emission unit: N/A
---	---	--

Provide a description of the emission unit (type, method of operation, design parameters, etc.):
Storage tank.

Manufacturer:	Model number:	Serial number:
----------------------	----------------------	-----------------------

Construction date: See Attachment D Equipment Table	Installation date: See Attachment D Equipment Table	Modification date(s): See Attachment D Equipment Table
---	---	--

Design Capacity (examples: furnaces - tons/hr, tanks - gallons): See Attachment D Equipment Table

Maximum Hourly Throughput:	Maximum Annual Throughput:	Maximum Operating Schedule: 24 hrs/day, 365 days/yr
-----------------------------------	-----------------------------------	---

Fuel Usage Data (fill out all applicable fields)

Does this emission unit combust fuel? <input type="checkbox"/> Yes <input checked="" type="checkbox"/> No	If yes, is it? <input type="checkbox"/> Indirect Fired <input type="checkbox"/> Direct Fired
--	--

Maximum design heat input and/or maximum horsepower rating:	Type and Btu/hr rating of burners:
--	---

List the primary fuel type(s) and if applicable, the secondary fuel type(s). For each fuel type listed, provide the maximum hourly and annual fuel usage for each.

Describe each fuel expected to be used during the term of the permit.

Fuel Type	Max. Sulfur Content	Max. Ash Content	BTU Value

<i>Emissions Data</i>		
Criteria Pollutants	Potential Emissions	
	PPH	TPY
Carbon Monoxide (CO)		
Nitrogen Oxides (NO _x)		
Lead (Pb)		
Particulate Matter (PM _{2.5})		
Particulate Matter (PM ₁₀)		
Total Particulate Matter (TSP)		
Sulfur Dioxide (SO ₂)		
Volatile Organic Compounds (VOC)		
Hazardous Air Pollutants	Potential Emissions	
	PPH	TPY
Regulated Pollutants other than Criteria and HAP	Potential Emissions	
	PPH	TPY

List the method(s) used to calculate the potential emissions (include dates of any stack tests conducted, versions of software used, source and dates of emission factors, etc.).

Applicable Requirements

List all applicable requirements for this emission unit. For each applicable requirement, include the underlying rule/regulation citation and/or construction permit with the condition number. (Note: Title V permit condition numbers alone are not the underlying applicable requirements). If an emission limit is calculated based on the type of source and design capacity or if a standard is based on a design parameter, this information should also be included.

From current Title V permit:

____ Permit Shield

For all applicable requirements listed above, provide monitoring/testing/recordkeeping/reporting which shall be used to demonstrate compliance. If the method is based on a permit or rule, include the condition number or citation. (Note: Each requirement listed above must have an associated method of demonstrating compliance. If there is not already a required method in place, then a method must be proposed.)

From current Title V permit:

Are you in compliance with all applicable requirements for this emission unit? Yes No

If no, complete the **Schedule of Compliance Form** as ATTACHMENT F.

ATTACHMENT E - Emission Unit Form

Emission Unit Description: *Storage Tank*

Emission unit ID number: 9625	Emission unit name: Tank 9625	List any control devices associated with this emission unit: N/A
---	---	--

Provide a description of the emission unit (type, method of operation, design parameters, etc.):
Storage tank.

Manufacturer:	Model number:	Serial number:
----------------------	----------------------	-----------------------

Construction date: See Attachment D Equipment Table	Installation date: See Attachment D Equipment Table	Modification date(s): See Attachment D Equipment Table
---	---	--

Design Capacity (examples: furnaces - tons/hr, tanks - gallons): See Attachment D Equipment Table

Maximum Hourly Throughput:	Maximum Annual Throughput:	Maximum Operating Schedule: 24 hrs/day, 365 days/yr
-----------------------------------	-----------------------------------	---

Fuel Usage Data (fill out all applicable fields)

Does this emission unit combust fuel? ___Yes ___X___ No	If yes, is it? ___ Indirect Fired ___ Direct Fired
--	--

Maximum design heat input and/or maximum horsepower rating:	Type and Btu/hr rating of burners:
--	---

List the primary fuel type(s) and if applicable, the secondary fuel type(s). For each fuel type listed, provide the maximum hourly and annual fuel usage for each.

Describe each fuel expected to be used during the term of the permit.

Fuel Type	Max. Sulfur Content	Max. Ash Content	BTU Value

<i>Emissions Data</i>		
Criteria Pollutants	Potential Emissions	
	PPH	TPY
Carbon Monoxide (CO)		
Nitrogen Oxides (NO _x)		
Lead (Pb)		
Particulate Matter (PM _{2.5})		
Particulate Matter (PM ₁₀)		
Total Particulate Matter (TSP)		
Sulfur Dioxide (SO ₂)		
Volatile Organic Compounds (VOC)		
Hazardous Air Pollutants	Potential Emissions	
	PPH	TPY
Regulated Pollutants other than Criteria and HAP	Potential Emissions	
	PPH	TPY

List the method(s) used to calculate the potential emissions (include dates of any stack tests conducted, versions of software used, source and dates of emission factors, etc.).

Applicable Requirements

List all applicable requirements for this emission unit. For each applicable requirement, include the underlying rule/regulation citation and/or **construction permit** with the condition number. (*Note: Title V permit condition numbers alone are not the underlying applicable requirements*). If an emission limit is calculated based on the type of source and design capacity or if a standard is based on a design parameter, this information should also be included.

From current Title V permit:

____ Permit Shield

For all applicable requirements listed above, provide monitoring/testing/recordkeeping/reporting which shall be used to demonstrate compliance. If the method is based on a permit or rule, include the condition number or citation. (*Note: Each requirement listed above must have an associated method of demonstrating compliance. If there is not already a required method in place, then a method must be proposed.*)

From current Title V permit:

Are you in compliance with all applicable requirements for this emission unit? Yes No

If no, complete the **Schedule of Compliance Form** as ATTACHMENT F.

ATTACHMENT E - Emission Unit Form

Emission Unit Description: *Storage Tank*

Emission unit ID number: 9627	Emission unit name: Tank 9627	List any control devices associated with this emission unit: N/A
---	---	--

Provide a description of the emission unit (type, method of operation, design parameters, etc.):
Storage tank.

Manufacturer:	Model number:	Serial number:
----------------------	----------------------	-----------------------

Construction date: See Attachment D Equipment Table	Installation date: See Attachment D Equipment Table	Modification date(s): See Attachment D Equipment Table
---	---	--

Design Capacity (examples: furnaces - tons/hr, tanks - gallons): See Attachment D Equipment Table

Maximum Hourly Throughput:	Maximum Annual Throughput:	Maximum Operating Schedule: 24 hrs/day, 365 days/yr
-----------------------------------	-----------------------------------	---

Fuel Usage Data (fill out all applicable fields)

Does this emission unit combust fuel? <input type="checkbox"/> Yes <input checked="" type="checkbox"/> No	If yes, is it? <input type="checkbox"/> Indirect Fired <input type="checkbox"/> Direct Fired
--	--

Maximum design heat input and/or maximum horsepower rating:	Type and Btu/hr rating of burners:
--	---

List the primary fuel type(s) and if applicable, the secondary fuel type(s). For each fuel type listed, provide the maximum hourly and annual fuel usage for each.

Describe each fuel expected to be used during the term of the permit.

Fuel Type	Max. Sulfur Content	Max. Ash Content	BTU Value

<i>Emissions Data</i>		
Criteria Pollutants	Potential Emissions	
	PPH	TPY
Carbon Monoxide (CO)		
Nitrogen Oxides (NO _x)		
Lead (Pb)		
Particulate Matter (PM _{2.5})		
Particulate Matter (PM ₁₀)		
Total Particulate Matter (TSP)		
Sulfur Dioxide (SO ₂)		
Volatile Organic Compounds (VOC)		
Hazardous Air Pollutants	Potential Emissions	
	PPH	TPY
Regulated Pollutants other than Criteria and HAP	Potential Emissions	
	PPH	TPY

List the method(s) used to calculate the potential emissions (include dates of any stack tests conducted, versions of software used, source and dates of emission factors, etc.).

Applicable Requirements

List all applicable requirements for this emission unit. For each applicable requirement, include the underlying rule/regulation citation and/or construction permit with the condition number. (Note: Title V permit condition numbers alone are not the underlying applicable requirements). If an emission limit is calculated based on the type of source and design capacity or if a standard is based on a design parameter, this information should also be included.

From current Title V permit:

____ Permit Shield

For all applicable requirements listed above, provide monitoring/testing/recordkeeping/reporting which shall be used to demonstrate compliance. If the method is based on a permit or rule, include the condition number or citation. (Note: Each requirement listed above must have an associated method of demonstrating compliance. If there is not already a required method in place, then a method must be proposed.)

From current Title V permit:

Are you in compliance with all applicable requirements for this emission unit? Yes No

If no, complete the **Schedule of Compliance Form** as ATTACHMENT F.

ATTACHMENT E - Emission Unit Form

Emission Unit Description: *Storage Tank*

Emission unit ID number: 9629	Emission unit name: Tank 9629	List any control devices associated with this emission unit: N/A
---	---	--

Provide a description of the emission unit (type, method of operation, design parameters, etc.):
Storage tank.

Manufacturer:	Model number:	Serial number:
----------------------	----------------------	-----------------------

Construction date: See Attachment D Equipment Table	Installation date: See Attachment D Equipment Table	Modification date(s): See Attachment D Equipment Table
---	---	--

Design Capacity (examples: furnaces - tons/hr, tanks - gallons): See Attachment D Equipment Table

Maximum Hourly Throughput:	Maximum Annual Throughput:	Maximum Operating Schedule: 24 hrs/day, 365 days/yr
-----------------------------------	-----------------------------------	---

Fuel Usage Data (fill out all applicable fields)

Does this emission unit combust fuel? ___Yes ___X___ No	If yes, is it? ___ Indirect Fired ___ Direct Fired
--	--

Maximum design heat input and/or maximum horsepower rating:	Type and Btu/hr rating of burners:
--	---

List the primary fuel type(s) and if applicable, the secondary fuel type(s). For each fuel type listed, provide the maximum hourly and annual fuel usage for each.

Describe each fuel expected to be used during the term of the permit.

Fuel Type	Max. Sulfur Content	Max. Ash Content	BTU Value

<i>Emissions Data</i>		
Criteria Pollutants	Potential Emissions	
	PPH	TPY
Carbon Monoxide (CO)		
Nitrogen Oxides (NO _x)		
Lead (Pb)		
Particulate Matter (PM _{2.5})		
Particulate Matter (PM ₁₀)		
Total Particulate Matter (TSP)		
Sulfur Dioxide (SO ₂)		
Volatile Organic Compounds (VOC)		
Hazardous Air Pollutants	Potential Emissions	
	PPH	TPY
Regulated Pollutants other than Criteria and HAP	Potential Emissions	
	PPH	TPY

List the method(s) used to calculate the potential emissions (include dates of any stack tests conducted, versions of software used, source and dates of emission factors, etc.).

Applicable Requirements

List all applicable requirements for this emission unit. For each applicable requirement, include the underlying rule/regulation citation and/or construction permit with the condition number. (Note: Title V permit condition numbers alone are not the underlying applicable requirements). If an emission limit is calculated based on the type of source and design capacity or if a standard is based on a design parameter, this information should also be included.

From current Title V permit:

____ Permit Shield

For all applicable requirements listed above, provide monitoring/testing/recordkeeping/reporting which shall be used to demonstrate compliance. If the method is based on a permit or rule, include the condition number or citation. (Note: Each requirement listed above must have an associated method of demonstrating compliance. If there is not already a required method in place, then a method must be proposed.)

From current Title V permit:

Are you in compliance with all applicable requirements for this emission unit? Yes No

If no, complete the **Schedule of Compliance Form** as ATTACHMENT F.

ATTACHMENT E - Emission Unit Form

Emission Unit Description: *Storage Tank*

Emission unit ID number: 9631	Emission unit name: Tank 9631	List any control devices associated with this emission unit: N/A
---	---	--

Provide a description of the emission unit (type, method of operation, design parameters, etc.):
Storage tank.

Manufacturer:	Model number:	Serial number:
----------------------	----------------------	-----------------------

Construction date: See Attachment D Equipment Table	Installation date: See Attachment D Equipment Table	Modification date(s): See Attachment D Equipment Table
---	---	--

Design Capacity (examples: furnaces - tons/hr, tanks - gallons): See Attachment D Equipment Table

Maximum Hourly Throughput:	Maximum Annual Throughput:	Maximum Operating Schedule: 24 hrs/day, 365 days/yr
-----------------------------------	-----------------------------------	---

Fuel Usage Data (fill out all applicable fields)

Does this emission unit combust fuel? ___Yes ___X___ No	If yes, is it? ___ Indirect Fired ___ Direct Fired
--	--

Maximum design heat input and/or maximum horsepower rating:	Type and Btu/hr rating of burners:
--	---

List the primary fuel type(s) and if applicable, the secondary fuel type(s). For each fuel type listed, provide the maximum hourly and annual fuel usage for each.

Describe each fuel expected to be used during the term of the permit.

Fuel Type	Max. Sulfur Content	Max. Ash Content	BTU Value

<i>Emissions Data</i>		
Criteria Pollutants	Potential Emissions	
	PPH	TPY
Carbon Monoxide (CO)		
Nitrogen Oxides (NO _x)		
Lead (Pb)		
Particulate Matter (PM _{2.5})		
Particulate Matter (PM ₁₀)		
Total Particulate Matter (TSP)		
Sulfur Dioxide (SO ₂)		
Volatile Organic Compounds (VOC)		
Hazardous Air Pollutants	Potential Emissions	
	PPH	TPY
Regulated Pollutants other than Criteria and HAP	Potential Emissions	
	PPH	TPY

List the method(s) used to calculate the potential emissions (include dates of any stack tests conducted, versions of software used, source and dates of emission factors, etc.).

Applicable Requirements

List all applicable requirements for this emission unit. For each applicable requirement, include the underlying rule/regulation citation and/or construction permit with the condition number. (Note: Title V permit condition numbers alone are not the underlying applicable requirements). If an emission limit is calculated based on the type of source and design capacity or if a standard is based on a design parameter, this information should also be included.

From current Title V permit:

____ Permit Shield

For all applicable requirements listed above, provide monitoring/testing/recordkeeping/reporting which shall be used to demonstrate compliance. If the method is based on a permit or rule, include the condition number or citation. (Note: Each requirement listed above must have an associated method of demonstrating compliance. If there is not already a required method in place, then a method must be proposed.)

From current Title V permit:

Are you in compliance with all applicable requirements for this emission unit? Yes No

If no, complete the **Schedule of Compliance Form** as ATTACHMENT F.

ATTACHMENT E - Emission Unit Form

Emission Unit Description: *Storage Tank*

Emission unit ID number: 9632	Emission unit name: Tank 9632	List any control devices associated with this emission unit: N/A
---	---	--

Provide a description of the emission unit (type, method of operation, design parameters, etc.):
Storage tank.

Manufacturer:	Model number:	Serial number:
----------------------	----------------------	-----------------------

Construction date: See Attachment D Equipment Table	Installation date: See Attachment D Equipment Table	Modification date(s): See Attachment D Equipment Table
---	---	--

Design Capacity (examples: furnaces - tons/hr, tanks - gallons): See Attachment D Equipment Table

Maximum Hourly Throughput:	Maximum Annual Throughput:	Maximum Operating Schedule: 24 hrs/day, 365 days/yr
-----------------------------------	-----------------------------------	---

Fuel Usage Data (fill out all applicable fields)

Does this emission unit combust fuel? ___Yes ___X___ No	If yes, is it? ___ Indirect Fired ___ Direct Fired
--	--

Maximum design heat input and/or maximum horsepower rating:	Type and Btu/hr rating of burners:
--	---

List the primary fuel type(s) and if applicable, the secondary fuel type(s). For each fuel type listed, provide the maximum hourly and annual fuel usage for each.

Describe each fuel expected to be used during the term of the permit.

Fuel Type	Max. Sulfur Content	Max. Ash Content	BTU Value

<i>Emissions Data</i>		
Criteria Pollutants	Potential Emissions	
	PPH	TPY
Carbon Monoxide (CO)		
Nitrogen Oxides (NO _x)		
Lead (Pb)		
Particulate Matter (PM _{2.5})		
Particulate Matter (PM ₁₀)		
Total Particulate Matter (TSP)		
Sulfur Dioxide (SO ₂)		
Volatile Organic Compounds (VOC)		
Hazardous Air Pollutants	Potential Emissions	
	PPH	TPY
Regulated Pollutants other than Criteria and HAP	Potential Emissions	
	PPH	TPY

List the method(s) used to calculate the potential emissions (include dates of any stack tests conducted, versions of software used, source and dates of emission factors, etc.).

Applicable Requirements

List all applicable requirements for this emission unit. For each applicable requirement, include the underlying rule/regulation citation and/or construction permit with the condition number. (Note: Title V permit condition numbers alone are not the underlying applicable requirements). If an emission limit is calculated based on the type of source and design capacity or if a standard is based on a design parameter, this information should also be included.

From current Title V permit:

____ Permit Shield

For all applicable requirements listed above, provide monitoring/testing/recordkeeping/reporting which shall be used to demonstrate compliance. If the method is based on a permit or rule, include the condition number or citation. (Note: Each requirement listed above must have an associated method of demonstrating compliance. If there is not already a required method in place, then a method must be proposed.)

From current Title V permit:

Are you in compliance with all applicable requirements for this emission unit? Yes No

If no, complete the **Schedule of Compliance Form** as ATTACHMENT F.

ATTACHMENT E - Emission Unit Form

Emission Unit Description: *Storage Tank*

Emission unit ID number: 9633	Emission unit name: Tank 9633	List any control devices associated with this emission unit: N/A
---	---	--

Provide a description of the emission unit (type, method of operation, design parameters, etc.):
Storage tank.

Manufacturer:	Model number:	Serial number:
----------------------	----------------------	-----------------------

Construction date: See Attachment D Equipment Table	Installation date: See Attachment D Equipment Table	Modification date(s): See Attachment D Equipment Table
---	---	--

Design Capacity (examples: furnaces - tons/hr, tanks - gallons): See Attachment D Equipment Table

Maximum Hourly Throughput:	Maximum Annual Throughput:	Maximum Operating Schedule: 24 hrs/day, 365 days/yr
-----------------------------------	-----------------------------------	---

Fuel Usage Data (fill out all applicable fields)

Does this emission unit combust fuel? ___Yes ___X___ No	If yes, is it? ___ Indirect Fired ___ Direct Fired
--	--

Maximum design heat input and/or maximum horsepower rating:	Type and Btu/hr rating of burners:
--	---

List the primary fuel type(s) and if applicable, the secondary fuel type(s). For each fuel type listed, provide the maximum hourly and annual fuel usage for each.

Describe each fuel expected to be used during the term of the permit.

Fuel Type	Max. Sulfur Content	Max. Ash Content	BTU Value

<i>Emissions Data</i>		
Criteria Pollutants	Potential Emissions	
	PPH	TPY
Carbon Monoxide (CO)		
Nitrogen Oxides (NO _x)		
Lead (Pb)		
Particulate Matter (PM _{2.5})		
Particulate Matter (PM ₁₀)		
Total Particulate Matter (TSP)		
Sulfur Dioxide (SO ₂)		
Volatile Organic Compounds (VOC)		
Hazardous Air Pollutants	Potential Emissions	
	PPH	TPY
Regulated Pollutants other than Criteria and HAP	Potential Emissions	
	PPH	TPY

List the method(s) used to calculate the potential emissions (include dates of any stack tests conducted, versions of software used, source and dates of emission factors, etc.).

Applicable Requirements

List all applicable requirements for this emission unit. For each applicable requirement, include the underlying rule/regulation citation and/or construction permit with the condition number. (Note: Title V permit condition numbers alone are not the underlying applicable requirements). If an emission limit is calculated based on the type of source and design capacity or if a standard is based on a design parameter, this information should also be included.

From current Title V permit:

____ Permit Shield

For all applicable requirements listed above, provide monitoring/testing/recordkeeping/reporting which shall be used to demonstrate compliance. If the method is based on a permit or rule, include the condition number or citation. (Note: Each requirement listed above must have an associated method of demonstrating compliance. If there is not already a required method in place, then a method must be proposed.)

From current Title V permit:

Are you in compliance with all applicable requirements for this emission unit? Yes No

If no, complete the **Schedule of Compliance Form** as ATTACHMENT F.

ATTACHMENT E - Emission Unit Form

Emission Unit Description: *Storage Tank*

Emission unit ID number: 9634	Emission unit name: Tank 9634	List any control devices associated with this emission unit: N/A
---	---	--

Provide a description of the emission unit (type, method of operation, design parameters, etc.):
Storage tank.

Manufacturer:	Model number:	Serial number:
----------------------	----------------------	-----------------------

Construction date: See Attachment D Equipment Table	Installation date: See Attachment D Equipment Table	Modification date(s): See Attachment D Equipment Table
---	---	--

Design Capacity (examples: furnaces - tons/hr, tanks - gallons): See Attachment D Equipment Table

Maximum Hourly Throughput:	Maximum Annual Throughput:	Maximum Operating Schedule: 24 hrs/day, 365 days/yr
-----------------------------------	-----------------------------------	---

Fuel Usage Data (fill out all applicable fields)

Does this emission unit combust fuel? ___Yes ___X___ No	If yes, is it? ___ Indirect Fired ___ Direct Fired
--	--

Maximum design heat input and/or maximum horsepower rating:	Type and Btu/hr rating of burners:
--	---

List the primary fuel type(s) and if applicable, the secondary fuel type(s). For each fuel type listed, provide the maximum hourly and annual fuel usage for each.

Describe each fuel expected to be used during the term of the permit.

Fuel Type	Max. Sulfur Content	Max. Ash Content	BTU Value

<i>Emissions Data</i>		
Criteria Pollutants	Potential Emissions	
	PPH	TPY
Carbon Monoxide (CO)		
Nitrogen Oxides (NO _x)		
Lead (Pb)		
Particulate Matter (PM _{2.5})		
Particulate Matter (PM ₁₀)		
Total Particulate Matter (TSP)		
Sulfur Dioxide (SO ₂)		
Volatile Organic Compounds (VOC)		
Hazardous Air Pollutants	Potential Emissions	
	PPH	TPY
Regulated Pollutants other than Criteria and HAP	Potential Emissions	
	PPH	TPY

List the method(s) used to calculate the potential emissions (include dates of any stack tests conducted, versions of software used, source and dates of emission factors, etc.).

Applicable Requirements

List all applicable requirements for this emission unit. For each applicable requirement, include the underlying rule/regulation citation and/or construction permit with the condition number. (Note: Title V permit condition numbers alone are not the underlying applicable requirements). If an emission limit is calculated based on the type of source and design capacity or if a standard is based on a design parameter, this information should also be included.

From current Title V permit:

____ Permit Shield

For all applicable requirements listed above, provide monitoring/testing/recordkeeping/reporting which shall be used to demonstrate compliance. If the method is based on a permit or rule, include the condition number or citation. (Note: Each requirement listed above must have an associated method of demonstrating compliance. If there is not already a required method in place, then a method must be proposed.)

From current Title V permit:

Are you in compliance with all applicable requirements for this emission unit? Yes No

If no, complete the **Schedule of Compliance Form** as ATTACHMENT F.

ATTACHMENT E - Emission Unit Form

Emission Unit Description: *Storage Tank*

Emission unit ID number: 9635	Emission unit name: Tank 9635	List any control devices associated with this emission unit: N/A
---	---	--

Provide a description of the emission unit (type, method of operation, design parameters, etc.):
Storage tank.

Manufacturer:	Model number:	Serial number:
----------------------	----------------------	-----------------------

Construction date: See Attachment D Equipment Table	Installation date: See Attachment D Equipment Table	Modification date(s): See Attachment D Equipment Table
---	---	--

Design Capacity (examples: furnaces - tons/hr, tanks - gallons): See Attachment D Equipment Table

Maximum Hourly Throughput:	Maximum Annual Throughput:	Maximum Operating Schedule: 24 hrs/day, 365 days/yr
-----------------------------------	-----------------------------------	---

Fuel Usage Data (fill out all applicable fields)

Does this emission unit combust fuel? ___Yes ___X___ No	If yes, is it? ___ Indirect Fired ___ Direct Fired
--	--

Maximum design heat input and/or maximum horsepower rating:	Type and Btu/hr rating of burners:
--	---

List the primary fuel type(s) and if applicable, the secondary fuel type(s). For each fuel type listed, provide the maximum hourly and annual fuel usage for each.

Describe each fuel expected to be used during the term of the permit.

Fuel Type	Max. Sulfur Content	Max. Ash Content	BTU Value

<i>Emissions Data</i>		
Criteria Pollutants	Potential Emissions	
	PPH	TPY
Carbon Monoxide (CO)		
Nitrogen Oxides (NO _x)		
Lead (Pb)		
Particulate Matter (PM _{2.5})		
Particulate Matter (PM ₁₀)		
Total Particulate Matter (TSP)		
Sulfur Dioxide (SO ₂)		
Volatile Organic Compounds (VOC)		
Hazardous Air Pollutants	Potential Emissions	
	PPH	TPY
Regulated Pollutants other than Criteria and HAP	Potential Emissions	
	PPH	TPY

List the method(s) used to calculate the potential emissions (include dates of any stack tests conducted, versions of software used, source and dates of emission factors, etc.).

Applicable Requirements

List all applicable requirements for this emission unit. For each applicable requirement, include the underlying rule/regulation citation and/or construction permit with the condition number. (Note: Title V permit condition numbers alone are not the underlying applicable requirements). If an emission limit is calculated based on the type of source and design capacity or if a standard is based on a design parameter, this information should also be included.

From current Title V permit:

____ Permit Shield

For all applicable requirements listed above, provide monitoring/testing/recordkeeping/reporting which shall be used to demonstrate compliance. If the method is based on a permit or rule, include the condition number or citation. (Note: Each requirement listed above must have an associated method of demonstrating compliance. If there is not already a required method in place, then a method must be proposed.)

From current Title V permit:

Are you in compliance with all applicable requirements for this emission unit? Yes No

If no, complete the **Schedule of Compliance Form** as ATTACHMENT F.

ATTACHMENT E - Emission Unit Form

Emission Unit Description: <i>Storage Tank</i>			
Emission unit ID number: 9636	Emission unit name: Tank 9636	List any control devices associated with this emission unit: N/A	
Provide a description of the emission unit (type, method of operation, design parameters, etc.): Storage tank (retained from AA) – currently out of service.			
Manufacturer:	Model number:	Serial number:	
Construction date: See Attachment D Equipment Table	Installation date: See Attachment D Equipment Table	Modification date(s): See Attachment D Equipment Table	
Design Capacity (examples: furnaces - tons/hr, tanks - gallons): See Attachment D Equipment Table			
Maximum Hourly Throughput:	Maximum Annual Throughput:	Maximum Operating Schedule:	
Fuel Usage Data (fill out all applicable fields)			
Does this emission unit combust fuel? ___Yes ___X___ No		If yes, is it? ___ Indirect Fired ___ Direct Fired	
Maximum design heat input and/or maximum horsepower rating:		Type and Btu/hr rating of burners:	
List the primary fuel type(s) and if applicable, the secondary fuel type(s). For each fuel type listed, provide the maximum hourly and annual fuel usage for each.			
Describe each fuel expected to be used during the term of the permit.			
Fuel Type	Max. Sulfur Content	Max. Ash Content	BTU Value

<i>Emissions Data</i>		
Criteria Pollutants	Potential Emissions	
	PPH	TPY
Carbon Monoxide (CO)		
Nitrogen Oxides (NO _x)		
Lead (Pb)		
Particulate Matter (PM _{2.5})		
Particulate Matter (PM ₁₀)		
Total Particulate Matter (TSP)		
Sulfur Dioxide (SO ₂)		
Volatile Organic Compounds (VOC)		
Hazardous Air Pollutants	Potential Emissions	
	PPH	TPY
Regulated Pollutants other than Criteria and HAP	Potential Emissions	
	PPH	TPY

List the method(s) used to calculate the potential emissions (include dates of any stack tests conducted, versions of software used, source and dates of emission factors, etc.).

Applicable Requirements

List all applicable requirements for this emission unit. For each applicable requirement, include the underlying rule/regulation citation and/or construction permit with the condition number. (Note: Title V permit condition numbers alone are not the underlying applicable requirements). If an emission limit is calculated based on the type of source and design capacity or if a standard is based on a design parameter, this information should also be included.

From current Title V permit:

____ Permit Shield

For all applicable requirements listed above, provide monitoring/testing/recordkeeping/reporting which shall be used to demonstrate compliance. If the method is based on a permit or rule, include the condition number or citation. (Note: Each requirement listed above must have an associated method of demonstrating compliance. If there is not already a required method in place, then a method must be proposed.)

From current Title V permit:

Are you in compliance with all applicable requirements for this emission unit? Yes No

If no, complete the **Schedule of Compliance Form** as ATTACHMENT F.

ATTACHMENT E - Emission Unit Form

Emission Unit Description: <i>Storage Tank</i>			
Emission unit ID number: 9637	Emission unit name: Tank 9637	List any control devices associated with this emission unit: N/A	
Provide a description of the emission unit (type, method of operation, design parameters, etc.): Storage tank.			
Manufacturer:	Model number:	Serial number:	
Construction date: See Attachment D Equipment Table	Installation date: See Attachment D Equipment Table	Modification date(s): See Attachment D Equipment Table	
Design Capacity (examples: furnaces - tons/hr, tanks - gallons): See Attachment D Equipment Table			
Maximum Hourly Throughput:	Maximum Annual Throughput:	Maximum Operating Schedule: 24 hrs/day, 365 days/yr	
Fuel Usage Data (fill out all applicable fields)			
Does this emission unit combust fuel? ___Yes ___X___ No		If yes, is it? ___ Indirect Fired ___ Direct Fired	
Maximum design heat input and/or maximum horsepower rating:		Type and Btu/hr rating of burners:	
List the primary fuel type(s) and if applicable, the secondary fuel type(s). For each fuel type listed, provide the maximum hourly and annual fuel usage for each.			
Describe each fuel expected to be used during the term of the permit.			
Fuel Type	Max. Sulfur Content	Max. Ash Content	BTU Value

<i>Emissions Data</i>		
Criteria Pollutants	Potential Emissions	
	PPH	TPY
Carbon Monoxide (CO)		
Nitrogen Oxides (NO _x)		
Lead (Pb)		
Particulate Matter (PM _{2.5})		
Particulate Matter (PM ₁₀)		
Total Particulate Matter (TSP)		
Sulfur Dioxide (SO ₂)		
Volatile Organic Compounds (VOC)		
Hazardous Air Pollutants	Potential Emissions	
	PPH	TPY
Regulated Pollutants other than Criteria and HAP	Potential Emissions	
	PPH	TPY

List the method(s) used to calculate the potential emissions (include dates of any stack tests conducted, versions of software used, source and dates of emission factors, etc.).

Applicable Requirements

List all applicable requirements for this emission unit. For each applicable requirement, include the underlying rule/regulation citation and/or construction permit with the condition number. (Note: Title V permit condition numbers alone are not the underlying applicable requirements). If an emission limit is calculated based on the type of source and design capacity or if a standard is based on a design parameter, this information should also be included.

From current Title V permit:

____ Permit Shield

For all applicable requirements listed above, provide monitoring/testing/recordkeeping/reporting which shall be used to demonstrate compliance. If the method is based on a permit or rule, include the condition number or citation. (Note: Each requirement listed above must have an associated method of demonstrating compliance. If there is not already a required method in place, then a method must be proposed.)

From current Title V permit:

Are you in compliance with all applicable requirements for this emission unit? Yes No

If no, complete the **Schedule of Compliance Form** as ATTACHMENT F.

ATTACHMENT E - Emission Unit Form

Emission Unit Description: *Storage Tank*

Emission unit ID number: 9638	Emission unit name: Tank 9638	List any control devices associated with this emission unit: N/A
---	---	--

Provide a description of the emission unit (type, method of operation, design parameters, etc.):
Storage tank.

Manufacturer:	Model number:	Serial number:
----------------------	----------------------	-----------------------

Construction date: See Attachment D Equipment Table	Installation date: See Attachment D Equipment Table	Modification date(s): See Attachment D Equipment Table
---	---	--

Design Capacity (examples: furnaces - tons/hr, tanks - gallons): See Attachment D Equipment Table

Maximum Hourly Throughput:	Maximum Annual Throughput:	Maximum Operating Schedule: 24 hrs/day, 365 days/yr
-----------------------------------	-----------------------------------	---

Fuel Usage Data (fill out all applicable fields)

Does this emission unit combust fuel? ___Yes ___X___ No	If yes, is it? ___ Indirect Fired ___ Direct Fired
--	--

Maximum design heat input and/or maximum horsepower rating:	Type and Btu/hr rating of burners:
--	---

List the primary fuel type(s) and if applicable, the secondary fuel type(s). For each fuel type listed, provide the maximum hourly and annual fuel usage for each.

Describe each fuel expected to be used during the term of the permit.

Fuel Type	Max. Sulfur Content	Max. Ash Content	BTU Value

<i>Emissions Data</i>		
Criteria Pollutants	Potential Emissions	
	PPH	TPY
Carbon Monoxide (CO)		
Nitrogen Oxides (NO _x)		
Lead (Pb)		
Particulate Matter (PM _{2.5})		
Particulate Matter (PM ₁₀)		
Total Particulate Matter (TSP)		
Sulfur Dioxide (SO ₂)		
Volatile Organic Compounds (VOC)		
Hazardous Air Pollutants	Potential Emissions	
	PPH	TPY
Regulated Pollutants other than Criteria and HAP	Potential Emissions	
	PPH	TPY

List the method(s) used to calculate the potential emissions (include dates of any stack tests conducted, versions of software used, source and dates of emission factors, etc.).

Applicable Requirements

List all applicable requirements for this emission unit. For each applicable requirement, include the underlying rule/regulation citation and/or construction permit with the condition number. (Note: Title V permit condition numbers alone are not the underlying applicable requirements). If an emission limit is calculated based on the type of source and design capacity or if a standard is based on a design parameter, this information should also be included.

From current Title V permit:

____ Permit Shield

For all applicable requirements listed above, provide monitoring/testing/recordkeeping/reporting which shall be used to demonstrate compliance. If the method is based on a permit or rule, include the condition number or citation. (Note: Each requirement listed above must have an associated method of demonstrating compliance. If there is not already a required method in place, then a method must be proposed.)

From current Title V permit:

Are you in compliance with all applicable requirements for this emission unit? Yes No

If no, complete the **Schedule of Compliance Form** as ATTACHMENT F.

ATTACHMENT E - Emission Unit Form

Emission Unit Description: <i>Storage Tank</i>			
Emission unit ID number: 9639	Emission unit name: Tank 9639	List any control devices associated with this emission unit: N/A	
Provide a description of the emission unit (type, method of operation, design parameters, etc.): Storage tank.			
Manufacturer:	Model number:	Serial number:	
Construction date: See Attachment D Equipment Table	Installation date: See Attachment D Equipment Table	Modification date(s): See Attachment D Equipment Table	
Design Capacity (examples: furnaces - tons/hr, tanks - gallons): See Attachment D Equipment Table			
Maximum Hourly Throughput:	Maximum Annual Throughput:	Maximum Operating Schedule: 24 hrs/day, 365 days/yr	
Fuel Usage Data (fill out all applicable fields)			
Does this emission unit combust fuel? ___Yes ___X___ No		If yes, is it? ___ Indirect Fired ___ Direct Fired	
Maximum design heat input and/or maximum horsepower rating:		Type and Btu/hr rating of burners:	
List the primary fuel type(s) and if applicable, the secondary fuel type(s). For each fuel type listed, provide the maximum hourly and annual fuel usage for each.			
Describe each fuel expected to be used during the term of the permit.			
Fuel Type	Max. Sulfur Content	Max. Ash Content	BTU Value

<i>Emissions Data</i>		
Criteria Pollutants	Potential Emissions	
	PPH	TPY
Carbon Monoxide (CO)		
Nitrogen Oxides (NO _x)		
Lead (Pb)		
Particulate Matter (PM _{2.5})		
Particulate Matter (PM ₁₀)		
Total Particulate Matter (TSP)		
Sulfur Dioxide (SO ₂)		
Volatile Organic Compounds (VOC)		
Hazardous Air Pollutants	Potential Emissions	
	PPH	TPY
Regulated Pollutants other than Criteria and HAP	Potential Emissions	
	PPH	TPY

List the method(s) used to calculate the potential emissions (include dates of any stack tests conducted, versions of software used, source and dates of emission factors, etc.).

Applicable Requirements

List all applicable requirements for this emission unit. For each applicable requirement, include the underlying rule/regulation citation and/or construction permit with the condition number. (Note: Title V permit condition numbers alone are not the underlying applicable requirements). If an emission limit is calculated based on the type of source and design capacity or if a standard is based on a design parameter, this information should also be included.

From current Title V permit:

____ Permit Shield

For all applicable requirements listed above, provide monitoring/testing/recordkeeping/reporting which shall be used to demonstrate compliance. If the method is based on a permit or rule, include the condition number or citation. (Note: Each requirement listed above must have an associated method of demonstrating compliance. If there is not already a required method in place, then a method must be proposed.)

From current Title V permit:

Are you in compliance with all applicable requirements for this emission unit? Yes No

If no, complete the **Schedule of Compliance Form** as ATTACHMENT F.

ATTACHMENT E - Emission Unit Form

Emission Unit Description: <i>Storage Tank</i>			
Emission unit ID number: 9640	Emission unit name: Tank 9640	List any control devices associated with this emission unit: N/A	
Provide a description of the emission unit (type, method of operation, design parameters, etc.): Storage tank.			
Manufacturer:	Model number:	Serial number:	
Construction date: See Attachment D Equipment Table	Installation date: See Attachment D Equipment Table	Modification date(s): See Attachment D Equipment Table	
Design Capacity (examples: furnaces - tons/hr, tanks - gallons): See Attachment D Equipment Table			
Maximum Hourly Throughput:	Maximum Annual Throughput:	Maximum Operating Schedule: 24 hrs/day, 365 days/yr	
Fuel Usage Data (fill out all applicable fields)			
Does this emission unit combust fuel? ___Yes ___X___ No		If yes, is it? ___ Indirect Fired ___ Direct Fired	
Maximum design heat input and/or maximum horsepower rating:		Type and Btu/hr rating of burners:	
List the primary fuel type(s) and if applicable, the secondary fuel type(s). For each fuel type listed, provide the maximum hourly and annual fuel usage for each.			
Describe each fuel expected to be used during the term of the permit.			
Fuel Type	Max. Sulfur Content	Max. Ash Content	BTU Value

<i>Emissions Data</i>		
Criteria Pollutants	Potential Emissions	
	PPH	TPY
Carbon Monoxide (CO)		
Nitrogen Oxides (NO _x)		
Lead (Pb)		
Particulate Matter (PM _{2.5})		
Particulate Matter (PM ₁₀)		
Total Particulate Matter (TSP)		
Sulfur Dioxide (SO ₂)		
Volatile Organic Compounds (VOC)		
Hazardous Air Pollutants	Potential Emissions	
	PPH	TPY
Regulated Pollutants other than Criteria and HAP	Potential Emissions	
	PPH	TPY

List the method(s) used to calculate the potential emissions (include dates of any stack tests conducted, versions of software used, source and dates of emission factors, etc.).

Applicable Requirements

List all applicable requirements for this emission unit. For each applicable requirement, include the underlying rule/regulation citation and/or construction permit with the condition number. (Note: Title V permit condition numbers alone are not the underlying applicable requirements). If an emission limit is calculated based on the type of source and design capacity or if a standard is based on a design parameter, this information should also be included.

From current Title V permit:

____ Permit Shield

For all applicable requirements listed above, provide monitoring/testing/recordkeeping/reporting which shall be used to demonstrate compliance. If the method is based on a permit or rule, include the condition number or citation. (Note: Each requirement listed above must have an associated method of demonstrating compliance. If there is not already a required method in place, then a method must be proposed.)

From current Title V permit:

Are you in compliance with all applicable requirements for this emission unit? Yes No

If no, complete the **Schedule of Compliance Form** as ATTACHMENT F.

ATTACHMENT E - Emission Unit Form

Emission Unit Description: *Storage Tank*

Emission unit ID number: 9641	Emission unit name: Tank 9641	List any control devices associated with this emission unit: N/A
---	---	--

Provide a description of the emission unit (type, method of operation, design parameters, etc.):
Storage tank.

Manufacturer:	Model number:	Serial number:
----------------------	----------------------	-----------------------

Construction date: See Attachment D Equipment Table	Installation date: See Attachment D Equipment Table	Modification date(s): See Attachment D Equipment Table
---	---	--

Design Capacity (examples: furnaces - tons/hr, tanks - gallons): See Attachment D Equipment Table

Maximum Hourly Throughput:	Maximum Annual Throughput:	Maximum Operating Schedule: 24 hrs/day, 365 days/yr
-----------------------------------	-----------------------------------	---

Fuel Usage Data (fill out all applicable fields)

Does this emission unit combust fuel? ___Yes ___X___ No	If yes, is it? ___ Indirect Fired ___ Direct Fired
--	--

Maximum design heat input and/or maximum horsepower rating:	Type and Btu/hr rating of burners:
--	---

List the primary fuel type(s) and if applicable, the secondary fuel type(s). For each fuel type listed, provide the maximum hourly and annual fuel usage for each.

Describe each fuel expected to be used during the term of the permit.

Fuel Type	Max. Sulfur Content	Max. Ash Content	BTU Value

<i>Emissions Data</i>		
Criteria Pollutants	Potential Emissions	
	PPH	TPY
Carbon Monoxide (CO)		
Nitrogen Oxides (NO _x)		
Lead (Pb)		
Particulate Matter (PM _{2.5})		
Particulate Matter (PM ₁₀)		
Total Particulate Matter (TSP)		
Sulfur Dioxide (SO ₂)		
Volatile Organic Compounds (VOC)		
Hazardous Air Pollutants	Potential Emissions	
	PPH	TPY
Regulated Pollutants other than Criteria and HAP	Potential Emissions	
	PPH	TPY

List the method(s) used to calculate the potential emissions (include dates of any stack tests conducted, versions of software used, source and dates of emission factors, etc.).

Applicable Requirements

List all applicable requirements for this emission unit. For each applicable requirement, include the underlying rule/regulation citation and/or construction permit with the condition number. (Note: Title V permit condition numbers alone are not the underlying applicable requirements). If an emission limit is calculated based on the type of source and design capacity or if a standard is based on a design parameter, this information should also be included.

From current Title V permit:

____ Permit Shield

For all applicable requirements listed above, provide monitoring/testing/recordkeeping/reporting which shall be used to demonstrate compliance. If the method is based on a permit or rule, include the condition number or citation. (Note: Each requirement listed above must have an associated method of demonstrating compliance. If there is not already a required method in place, then a method must be proposed.)

From current Title V permit:

Are you in compliance with all applicable requirements for this emission unit? Yes No

If no, complete the **Schedule of Compliance Form** as ATTACHMENT F.

ATTACHMENT E - Emission Unit Form

Emission Unit Description: *Storage Tank*

Emission unit ID number: 9642	Emission unit name: Tank 9642	List any control devices associated with this emission unit: N/A
---	---	--

Provide a description of the emission unit (type, method of operation, design parameters, etc.):
Storage tank.

Manufacturer:	Model number:	Serial number:
----------------------	----------------------	-----------------------

Construction date: See Attachment D Equipment Table	Installation date: See Attachment D Equipment Table	Modification date(s): See Attachment D Equipment Table
---	---	--

Design Capacity (examples: furnaces - tons/hr, tanks - gallons): See Attachment D Equipment Table

Maximum Hourly Throughput:	Maximum Annual Throughput:	Maximum Operating Schedule: 24 hrs/day, 365 days/yr
-----------------------------------	-----------------------------------	---

Fuel Usage Data (fill out all applicable fields)

Does this emission unit combust fuel? ___Yes ___X___ No	If yes, is it? ___ Indirect Fired ___ Direct Fired
--	--

Maximum design heat input and/or maximum horsepower rating:	Type and Btu/hr rating of burners:
--	---

List the primary fuel type(s) and if applicable, the secondary fuel type(s). For each fuel type listed, provide the maximum hourly and annual fuel usage for each.

Describe each fuel expected to be used during the term of the permit.

Fuel Type	Max. Sulfur Content	Max. Ash Content	BTU Value

<i>Emissions Data</i>		
Criteria Pollutants	Potential Emissions	
	PPH	TPY
Carbon Monoxide (CO)		
Nitrogen Oxides (NO _x)		
Lead (Pb)		
Particulate Matter (PM _{2.5})		
Particulate Matter (PM ₁₀)		
Total Particulate Matter (TSP)		
Sulfur Dioxide (SO ₂)		
Volatile Organic Compounds (VOC)		
Hazardous Air Pollutants	Potential Emissions	
	PPH	TPY
Regulated Pollutants other than Criteria and HAP	Potential Emissions	
	PPH	TPY

List the method(s) used to calculate the potential emissions (include dates of any stack tests conducted, versions of software used, source and dates of emission factors, etc.).

Applicable Requirements

List all applicable requirements for this emission unit. For each applicable requirement, include the underlying rule/regulation citation and/or construction permit with the condition number. (Note: Title V permit condition numbers alone are not the underlying applicable requirements). If an emission limit is calculated based on the type of source and design capacity or if a standard is based on a design parameter, this information should also be included.

From current Title V permit:

____ Permit Shield

For all applicable requirements listed above, provide monitoring/testing/recordkeeping/reporting which shall be used to demonstrate compliance. If the method is based on a permit or rule, include the condition number or citation. (Note: Each requirement listed above must have an associated method of demonstrating compliance. If there is not already a required method in place, then a method must be proposed.)

From current Title V permit:

Are you in compliance with all applicable requirements for this emission unit? Yes No

If no, complete the **Schedule of Compliance Form** as ATTACHMENT F.

ATTACHMENT E - Emission Unit Form

Emission Unit Description: *Storage Tank*

Emission unit ID number: 9643	Emission unit name: Tank 9643	List any control devices associated with this emission unit: N/A
---	---	--

Provide a description of the emission unit (type, method of operation, design parameters, etc.):
Storage tank.

Manufacturer:	Model number:	Serial number:
----------------------	----------------------	-----------------------

Construction date: See Attachment D Equipment Table	Installation date: See Attachment D Equipment Table	Modification date(s): See Attachment D Equipment Table
---	---	--

Design Capacity (examples: furnaces - tons/hr, tanks - gallons): See Attachment D Equipment Table

Maximum Hourly Throughput:	Maximum Annual Throughput:	Maximum Operating Schedule: 24 hrs/day, 365 days/yr
-----------------------------------	-----------------------------------	---

Fuel Usage Data (fill out all applicable fields)

Does this emission unit combust fuel? ___Yes ___X___ No	If yes, is it? ___ Indirect Fired ___ Direct Fired
--	--

Maximum design heat input and/or maximum horsepower rating:	Type and Btu/hr rating of burners:
--	---

List the primary fuel type(s) and if applicable, the secondary fuel type(s). For each fuel type listed, provide the maximum hourly and annual fuel usage for each.

Describe each fuel expected to be used during the term of the permit.

Fuel Type	Max. Sulfur Content	Max. Ash Content	BTU Value

<i>Emissions Data</i>		
Criteria Pollutants	Potential Emissions	
	PPH	TPY
Carbon Monoxide (CO)		
Nitrogen Oxides (NO _x)		
Lead (Pb)		
Particulate Matter (PM _{2.5})		
Particulate Matter (PM ₁₀)		
Total Particulate Matter (TSP)		
Sulfur Dioxide (SO ₂)		
Volatile Organic Compounds (VOC)		
Hazardous Air Pollutants	Potential Emissions	
	PPH	TPY
Regulated Pollutants other than Criteria and HAP	Potential Emissions	
	PPH	TPY

List the method(s) used to calculate the potential emissions (include dates of any stack tests conducted, versions of software used, source and dates of emission factors, etc.).

Applicable Requirements

List all applicable requirements for this emission unit. For each applicable requirement, include the underlying rule/regulation citation and/or construction permit with the condition number. (Note: Title V permit condition numbers alone are not the underlying applicable requirements). If an emission limit is calculated based on the type of source and design capacity or if a standard is based on a design parameter, this information should also be included.

From current Title V permit:

____ Permit Shield

For all applicable requirements listed above, provide monitoring/testing/recordkeeping/reporting which shall be used to demonstrate compliance. If the method is based on a permit or rule, include the condition number or citation. (Note: Each requirement listed above must have an associated method of demonstrating compliance. If there is not already a required method in place, then a method must be proposed.)

From current Title V permit:

Are you in compliance with all applicable requirements for this emission unit? Yes No

If no, complete the **Schedule of Compliance Form** as ATTACHMENT F.

ATTACHMENT E - Emission Unit Form

Emission Unit Description: <i>Storage Tank</i>			
Emission unit ID number: 9644	Emission unit name: Tank 9644	List any control devices associated with this emission unit: N/A	
Provide a description of the emission unit (type, method of operation, design parameters, etc.): Storage tank.			
Manufacturer:	Model number:	Serial number:	
Construction date: See Attachment D Equipment Table	Installation date: See Attachment D Equipment Table	Modification date(s): See Attachment D Equipment Table	
Design Capacity (examples: furnaces - tons/hr, tanks - gallons): See Attachment D Equipment Table			
Maximum Hourly Throughput:	Maximum Annual Throughput:	Maximum Operating Schedule: 24 hrs/day, 365 days/yr	
Fuel Usage Data (fill out all applicable fields)			
Does this emission unit combust fuel? ___Yes ___X___ No		If yes, is it? ___ Indirect Fired ___ Direct Fired	
Maximum design heat input and/or maximum horsepower rating:		Type and Btu/hr rating of burners:	
List the primary fuel type(s) and if applicable, the secondary fuel type(s). For each fuel type listed, provide the maximum hourly and annual fuel usage for each.			
Describe each fuel expected to be used during the term of the permit.			
Fuel Type	Max. Sulfur Content	Max. Ash Content	BTU Value

<i>Emissions Data</i>		
Criteria Pollutants	Potential Emissions	
	PPH	TPY
Carbon Monoxide (CO)		
Nitrogen Oxides (NO _x)		
Lead (Pb)		
Particulate Matter (PM _{2.5})		
Particulate Matter (PM ₁₀)		
Total Particulate Matter (TSP)		
Sulfur Dioxide (SO ₂)		
Volatile Organic Compounds (VOC)		
Hazardous Air Pollutants	Potential Emissions	
	PPH	TPY
Regulated Pollutants other than Criteria and HAP	Potential Emissions	
	PPH	TPY

List the method(s) used to calculate the potential emissions (include dates of any stack tests conducted, versions of software used, source and dates of emission factors, etc.).

Applicable Requirements

List all applicable requirements for this emission unit. For each applicable requirement, include the underlying rule/regulation citation and/or construction permit with the condition number. (Note: Title V permit condition numbers alone are not the underlying applicable requirements). If an emission limit is calculated based on the type of source and design capacity or if a standard is based on a design parameter, this information should also be included.

From current Title V permit:

____ Permit Shield

For all applicable requirements listed above, provide monitoring/testing/recordkeeping/reporting which shall be used to demonstrate compliance. If the method is based on a permit or rule, include the condition number or citation. (Note: Each requirement listed above must have an associated method of demonstrating compliance. If there is not already a required method in place, then a method must be proposed.)

From current Title V permit:

Are you in compliance with all applicable requirements for this emission unit? Yes No

If no, complete the **Schedule of Compliance Form** as ATTACHMENT F.

ATTACHMENT E - Emission Unit Form

Emission Unit Description: *Storage Tank*

Emission unit ID number: 9645	Emission unit name: Tank 9645	List any control devices associated with this emission unit: N/A
---	---	--

Provide a description of the emission unit (type, method of operation, design parameters, etc.):
Storage tank.

Manufacturer:	Model number:	Serial number:
----------------------	----------------------	-----------------------

Construction date: See Attachment D Equipment Table	Installation date: See Attachment D Equipment Table	Modification date(s): See Attachment D Equipment Table
---	---	--

Design Capacity (examples: furnaces - tons/hr, tanks - gallons): See Attachment D Equipment Table

Maximum Hourly Throughput:	Maximum Annual Throughput:	Maximum Operating Schedule: 24 hrs/day, 365 days/yr
-----------------------------------	-----------------------------------	---

Fuel Usage Data (fill out all applicable fields)

Does this emission unit combust fuel? ___Yes ___X___ No	If yes, is it? ___ Indirect Fired ___ Direct Fired
--	--

Maximum design heat input and/or maximum horsepower rating:	Type and Btu/hr rating of burners:
--	---

List the primary fuel type(s) and if applicable, the secondary fuel type(s). For each fuel type listed, provide the maximum hourly and annual fuel usage for each.

Describe each fuel expected to be used during the term of the permit.

Fuel Type	Max. Sulfur Content	Max. Ash Content	BTU Value

<i>Emissions Data</i>		
Criteria Pollutants	Potential Emissions	
	PPH	TPY
Carbon Monoxide (CO)		
Nitrogen Oxides (NO _x)		
Lead (Pb)		
Particulate Matter (PM _{2.5})		
Particulate Matter (PM ₁₀)		
Total Particulate Matter (TSP)		
Sulfur Dioxide (SO ₂)		
Volatile Organic Compounds (VOC)		
Hazardous Air Pollutants	Potential Emissions	
	PPH	TPY
Regulated Pollutants other than Criteria and HAP	Potential Emissions	
	PPH	TPY

List the method(s) used to calculate the potential emissions (include dates of any stack tests conducted, versions of software used, source and dates of emission factors, etc.).

Applicable Requirements

List all applicable requirements for this emission unit. For each applicable requirement, include the underlying rule/regulation citation and/or construction permit with the condition number. (Note: Title V permit condition numbers alone are not the underlying applicable requirements). If an emission limit is calculated based on the type of source and design capacity or if a standard is based on a design parameter, this information should also be included.

From current Title V permit:

____ Permit Shield

For all applicable requirements listed above, provide monitoring/testing/recordkeeping/reporting which shall be used to demonstrate compliance. If the method is based on a permit or rule, include the condition number or citation. (Note: Each requirement listed above must have an associated method of demonstrating compliance. If there is not already a required method in place, then a method must be proposed.)

From current Title V permit:

Are you in compliance with all applicable requirements for this emission unit? Yes No

If no, complete the **Schedule of Compliance Form** as ATTACHMENT F.

ATTACHMENT E - Emission Unit Form

Emission Unit Description: *Storage Tank*

Emission unit ID number: 9646	Emission unit name: Tank 9646	List any control devices associated with this emission unit: N/A
---	---	--

Provide a description of the emission unit (type, method of operation, design parameters, etc.):
Storage tank.

Manufacturer:	Model number:	Serial number:
----------------------	----------------------	-----------------------

Construction date: See Attachment D Equipment Table	Installation date: See Attachment D Equipment Table	Modification date(s): See Attachment D Equipment Table
---	---	--

Design Capacity (examples: furnaces - tons/hr, tanks - gallons): See Attachment D Equipment Table

Maximum Hourly Throughput:	Maximum Annual Throughput:	Maximum Operating Schedule: 24 hrs/day, 365 days/yr
-----------------------------------	-----------------------------------	---

Fuel Usage Data (fill out all applicable fields)

Does this emission unit combust fuel? ___Yes ___X___ No	If yes, is it? ___ Indirect Fired ___ Direct Fired
--	--

Maximum design heat input and/or maximum horsepower rating:	Type and Btu/hr rating of burners:
--	---

List the primary fuel type(s) and if applicable, the secondary fuel type(s). For each fuel type listed, provide the maximum hourly and annual fuel usage for each.

Describe each fuel expected to be used during the term of the permit.

Fuel Type	Max. Sulfur Content	Max. Ash Content	BTU Value

<i>Emissions Data</i>		
Criteria Pollutants	Potential Emissions	
	PPH	TPY
Carbon Monoxide (CO)		
Nitrogen Oxides (NO _x)		
Lead (Pb)		
Particulate Matter (PM _{2.5})		
Particulate Matter (PM ₁₀)		
Total Particulate Matter (TSP)		
Sulfur Dioxide (SO ₂)		
Volatile Organic Compounds (VOC)		
Hazardous Air Pollutants	Potential Emissions	
	PPH	TPY
Regulated Pollutants other than Criteria and HAP	Potential Emissions	
	PPH	TPY

List the method(s) used to calculate the potential emissions (include dates of any stack tests conducted, versions of software used, source and dates of emission factors, etc.).

Applicable Requirements

List all applicable requirements for this emission unit. For each applicable requirement, include the underlying rule/regulation citation and/or construction permit with the condition number. (Note: Title V permit condition numbers alone are not the underlying applicable requirements). If an emission limit is calculated based on the type of source and design capacity or if a standard is based on a design parameter, this information should also be included.

From current Title V permit:

____ Permit Shield

For all applicable requirements listed above, provide monitoring/testing/recordkeeping/reporting which shall be used to demonstrate compliance. If the method is based on a permit or rule, include the condition number or citation. (Note: Each requirement listed above must have an associated method of demonstrating compliance. If there is not already a required method in place, then a method must be proposed.)

From current Title V permit:

Are you in compliance with all applicable requirements for this emission unit? Yes No

If no, complete the **Schedule of Compliance Form** as ATTACHMENT F.

ATTACHMENT E - Emission Unit Form

Emission Unit Description: *Storage Tank*

Emission unit ID number: 9647	Emission unit name: Tank 9647	List any control devices associated with this emission unit: N/A
---	---	--

Provide a description of the emission unit (type, method of operation, design parameters, etc.):
Storage tank.

Manufacturer:	Model number:	Serial number:
----------------------	----------------------	-----------------------

Construction date: See Attachment D Equipment Table	Installation date: See Attachment D Equipment Table	Modification date(s): See Attachment D Equipment Table
---	---	--

Design Capacity (examples: furnaces - tons/hr, tanks - gallons): See Attachment D Equipment Table

Maximum Hourly Throughput:	Maximum Annual Throughput:	Maximum Operating Schedule: 24 hrs/day, 365 days/yr
-----------------------------------	-----------------------------------	---

Fuel Usage Data (fill out all applicable fields)

Does this emission unit combust fuel? <input type="checkbox"/> Yes <input checked="" type="checkbox"/> No	If yes, is it? <input type="checkbox"/> Indirect Fired <input type="checkbox"/> Direct Fired
--	--

Maximum design heat input and/or maximum horsepower rating:	Type and Btu/hr rating of burners:
--	---

List the primary fuel type(s) and if applicable, the secondary fuel type(s). For each fuel type listed, provide the maximum hourly and annual fuel usage for each.

Describe each fuel expected to be used during the term of the permit.

Fuel Type	Max. Sulfur Content	Max. Ash Content	BTU Value

<i>Emissions Data</i>		
Criteria Pollutants	Potential Emissions	
	PPH	TPY
Carbon Monoxide (CO)		
Nitrogen Oxides (NO _x)		
Lead (Pb)		
Particulate Matter (PM _{2.5})		
Particulate Matter (PM ₁₀)		
Total Particulate Matter (TSP)		
Sulfur Dioxide (SO ₂)		
Volatile Organic Compounds (VOC)		
Hazardous Air Pollutants	Potential Emissions	
	PPH	TPY
Regulated Pollutants other than Criteria and HAP	Potential Emissions	
	PPH	TPY

List the method(s) used to calculate the potential emissions (include dates of any stack tests conducted, versions of software used, source and dates of emission factors, etc.).

Applicable Requirements

List all applicable requirements for this emission unit. For each applicable requirement, include the underlying rule/regulation citation and/or construction permit with the condition number. (Note: Title V permit condition numbers alone are not the underlying applicable requirements). If an emission limit is calculated based on the type of source and design capacity or if a standard is based on a design parameter, this information should also be included.

From current Title V permit:

____ Permit Shield

For all applicable requirements listed above, provide monitoring/testing/recordkeeping/reporting which shall be used to demonstrate compliance. If the method is based on a permit or rule, include the condition number or citation. (Note: Each requirement listed above must have an associated method of demonstrating compliance. If there is not already a required method in place, then a method must be proposed.)

From current Title V permit:

Are you in compliance with all applicable requirements for this emission unit? Yes No

If no, complete the **Schedule of Compliance Form** as ATTACHMENT F.

ATTACHMENT E - Emission Unit Form

Emission Unit Description: *Storage Tank*

Emission unit ID number: 9648	Emission unit name: Tank 9648	List any control devices associated with this emission unit: N/A
---	---	--

Provide a description of the emission unit (type, method of operation, design parameters, etc.):
Storage tank.

Manufacturer:	Model number:	Serial number:
----------------------	----------------------	-----------------------

Construction date: See Attachment D Equipment Table	Installation date: See Attachment D Equipment Table	Modification date(s): See Attachment D Equipment Table
---	---	--

Design Capacity (examples: furnaces - tons/hr, tanks - gallons): See Attachment D Equipment Table

Maximum Hourly Throughput:	Maximum Annual Throughput:	Maximum Operating Schedule: 24 hrs/day, 365 days/yr
-----------------------------------	-----------------------------------	---

Fuel Usage Data (fill out all applicable fields)

Does this emission unit combust fuel? ___Yes ___X___ No	If yes, is it? ___ Indirect Fired ___ Direct Fired
--	--

Maximum design heat input and/or maximum horsepower rating:	Type and Btu/hr rating of burners:
--	---

List the primary fuel type(s) and if applicable, the secondary fuel type(s). For each fuel type listed, provide the maximum hourly and annual fuel usage for each.

Describe each fuel expected to be used during the term of the permit.

Fuel Type	Max. Sulfur Content	Max. Ash Content	BTU Value

<i>Emissions Data</i>		
Criteria Pollutants	Potential Emissions	
	PPH	TPY
Carbon Monoxide (CO)		
Nitrogen Oxides (NO _x)		
Lead (Pb)		
Particulate Matter (PM _{2.5})		
Particulate Matter (PM ₁₀)		
Total Particulate Matter (TSP)		
Sulfur Dioxide (SO ₂)		
Volatile Organic Compounds (VOC)		
Hazardous Air Pollutants	Potential Emissions	
	PPH	TPY
Regulated Pollutants other than Criteria and HAP	Potential Emissions	
	PPH	TPY

List the method(s) used to calculate the potential emissions (include dates of any stack tests conducted, versions of software used, source and dates of emission factors, etc.).

Applicable Requirements

List all applicable requirements for this emission unit. For each applicable requirement, include the underlying rule/regulation citation and/or construction permit with the condition number. (Note: Title V permit condition numbers alone are not the underlying applicable requirements). If an emission limit is calculated based on the type of source and design capacity or if a standard is based on a design parameter, this information should also be included.

From current Title V permit:

____ Permit Shield

For all applicable requirements listed above, provide monitoring/testing/recordkeeping/reporting which shall be used to demonstrate compliance. If the method is based on a permit or rule, include the condition number or citation. (Note: Each requirement listed above must have an associated method of demonstrating compliance. If there is not already a required method in place, then a method must be proposed.)

From current Title V permit:

Are you in compliance with all applicable requirements for this emission unit? Yes No

If no, complete the **Schedule of Compliance Form** as ATTACHMENT F.

ATTACHMENT E - Emission Unit Form

Emission Unit Description: *Storage Tank*

Emission unit ID number: 9649	Emission unit name: Tank 9649	List any control devices associated with this emission unit: N/A
---	---	--

Provide a description of the emission unit (type, method of operation, design parameters, etc.):
Storage tank.

Manufacturer:	Model number:	Serial number:
----------------------	----------------------	-----------------------

Construction date: See Attachment D Equipment Table	Installation date: See Attachment D Equipment Table	Modification date(s): See Attachment D Equipment Table
---	---	--

Design Capacity (examples: furnaces - tons/hr, tanks - gallons): See Attachment D Equipment Table

Maximum Hourly Throughput:	Maximum Annual Throughput:	Maximum Operating Schedule: 24 hrs/day, 365 days/yr
-----------------------------------	-----------------------------------	---

Fuel Usage Data (fill out all applicable fields)

Does this emission unit combust fuel? ___Yes ___X___ No	If yes, is it? ___ Indirect Fired ___ Direct Fired
--	--

Maximum design heat input and/or maximum horsepower rating:	Type and Btu/hr rating of burners:
--	---

List the primary fuel type(s) and if applicable, the secondary fuel type(s). For each fuel type listed, provide the maximum hourly and annual fuel usage for each.

Describe each fuel expected to be used during the term of the permit.

Fuel Type	Max. Sulfur Content	Max. Ash Content	BTU Value

<i>Emissions Data</i>		
Criteria Pollutants	Potential Emissions	
	PPH	TPY
Carbon Monoxide (CO)		
Nitrogen Oxides (NO _x)		
Lead (Pb)		
Particulate Matter (PM _{2.5})		
Particulate Matter (PM ₁₀)		
Total Particulate Matter (TSP)		
Sulfur Dioxide (SO ₂)		
Volatile Organic Compounds (VOC)		
Hazardous Air Pollutants	Potential Emissions	
	PPH	TPY
Regulated Pollutants other than Criteria and HAP	Potential Emissions	
	PPH	TPY

List the method(s) used to calculate the potential emissions (include dates of any stack tests conducted, versions of software used, source and dates of emission factors, etc.).

Applicable Requirements

List all applicable requirements for this emission unit. For each applicable requirement, include the underlying rule/regulation citation and/or construction permit with the condition number. (Note: Title V permit condition numbers alone are not the underlying applicable requirements). If an emission limit is calculated based on the type of source and design capacity or if a standard is based on a design parameter, this information should also be included.

From current Title V permit:

____ Permit Shield

For all applicable requirements listed above, provide monitoring/testing/recordkeeping/reporting which shall be used to demonstrate compliance. If the method is based on a permit or rule, include the condition number or citation. (Note: Each requirement listed above must have an associated method of demonstrating compliance. If there is not already a required method in place, then a method must be proposed.)

From current Title V permit:

Are you in compliance with all applicable requirements for this emission unit? Yes No

If no, complete the **Schedule of Compliance Form** as ATTACHMENT F.

ATTACHMENT E - Emission Unit Form

Emission Unit Description: *Storage Tank*

Emission unit ID number: 9650	Emission unit name: Tank 9650	List any control devices associated with this emission unit: N/A
---	---	--

Provide a description of the emission unit (type, method of operation, design parameters, etc.):
Storage tank.

Manufacturer:	Model number:	Serial number:
----------------------	----------------------	-----------------------

Construction date: See Attachment D Equipment Table	Installation date: See Attachment D Equipment Table	Modification date(s): See Attachment D Equipment Table
---	---	--

Design Capacity (examples: furnaces - tons/hr, tanks - gallons): See Attachment D Equipment Table

Maximum Hourly Throughput:	Maximum Annual Throughput:	Maximum Operating Schedule: 24 hrs/day, 365 days/yr
-----------------------------------	-----------------------------------	---

Fuel Usage Data (fill out all applicable fields)

Does this emission unit combust fuel? ___Yes ___X___ No	If yes, is it? ___ Indirect Fired ___ Direct Fired
--	--

Maximum design heat input and/or maximum horsepower rating:	Type and Btu/hr rating of burners:
--	---

List the primary fuel type(s) and if applicable, the secondary fuel type(s). For each fuel type listed, provide the maximum hourly and annual fuel usage for each.

Describe each fuel expected to be used during the term of the permit.

Fuel Type	Max. Sulfur Content	Max. Ash Content	BTU Value

<i>Emissions Data</i>		
Criteria Pollutants	Potential Emissions	
	PPH	TPY
Carbon Monoxide (CO)		
Nitrogen Oxides (NO _x)		
Lead (Pb)		
Particulate Matter (PM _{2.5})		
Particulate Matter (PM ₁₀)		
Total Particulate Matter (TSP)		
Sulfur Dioxide (SO ₂)		
Volatile Organic Compounds (VOC)		
Hazardous Air Pollutants	Potential Emissions	
	PPH	TPY
Regulated Pollutants other than Criteria and HAP	Potential Emissions	
	PPH	TPY

List the method(s) used to calculate the potential emissions (include dates of any stack tests conducted, versions of software used, source and dates of emission factors, etc.).

Applicable Requirements

List all applicable requirements for this emission unit. For each applicable requirement, include the underlying rule/regulation citation and/or **construction permit** with the condition number. (*Note: Title V permit condition numbers alone are not the underlying applicable requirements*). If an emission limit is calculated based on the type of source and design capacity or if a standard is based on a design parameter, this information should also be included.

From current Title V permit:

____ Permit Shield

For all applicable requirements listed above, provide monitoring/testing/recordkeeping/reporting which shall be used to demonstrate compliance. If the method is based on a permit or rule, include the condition number or citation. (*Note: Each requirement listed above must have an associated method of demonstrating compliance. If there is not already a required method in place, then a method must be proposed.*)

From current Title V permit:

Are you in compliance with all applicable requirements for this emission unit? Yes No

If no, complete the **Schedule of Compliance Form** as ATTACHMENT F.

ATTACHMENT E - Emission Unit Form

Emission Unit Description: *Storage Tank*

Emission unit ID number: 9651	Emission unit name: Tank 9651	List any control devices associated with this emission unit: N/A
---	---	--

Provide a description of the emission unit (type, method of operation, design parameters, etc.):
Storage tank.

Manufacturer:	Model number:	Serial number:
----------------------	----------------------	-----------------------

Construction date: See Attachment D Equipment Table	Installation date: See Attachment D Equipment Table	Modification date(s): See Attachment D Equipment Table
---	---	--

Design Capacity (examples: furnaces - tons/hr, tanks - gallons): See Attachment D Equipment Table

Maximum Hourly Throughput:	Maximum Annual Throughput:	Maximum Operating Schedule: 24 hrs/day, 365 days/yr
-----------------------------------	-----------------------------------	---

Fuel Usage Data (fill out all applicable fields)

Does this emission unit combust fuel? ___Yes ___X___ No	If yes, is it? ___ Indirect Fired ___ Direct Fired
--	--

Maximum design heat input and/or maximum horsepower rating:	Type and Btu/hr rating of burners:
--	---

List the primary fuel type(s) and if applicable, the secondary fuel type(s). For each fuel type listed, provide the maximum hourly and annual fuel usage for each.

Describe each fuel expected to be used during the term of the permit.

Fuel Type	Max. Sulfur Content	Max. Ash Content	BTU Value

<i>Emissions Data</i>		
Criteria Pollutants	Potential Emissions	
	PPH	TPY
Carbon Monoxide (CO)		
Nitrogen Oxides (NO _x)		
Lead (Pb)		
Particulate Matter (PM _{2.5})		
Particulate Matter (PM ₁₀)		
Total Particulate Matter (TSP)		
Sulfur Dioxide (SO ₂)		
Volatile Organic Compounds (VOC)		
Hazardous Air Pollutants	Potential Emissions	
	PPH	TPY
Regulated Pollutants other than Criteria and HAP	Potential Emissions	
	PPH	TPY

List the method(s) used to calculate the potential emissions (include dates of any stack tests conducted, versions of software used, source and dates of emission factors, etc.).

Applicable Requirements

List all applicable requirements for this emission unit. For each applicable requirement, include the underlying rule/regulation citation and/or construction permit with the condition number. (Note: Title V permit condition numbers alone are not the underlying applicable requirements). If an emission limit is calculated based on the type of source and design capacity or if a standard is based on a design parameter, this information should also be included.

From current Title V permit:

____ Permit Shield

For all applicable requirements listed above, provide monitoring/testing/recordkeeping/reporting which shall be used to demonstrate compliance. If the method is based on a permit or rule, include the condition number or citation. (Note: Each requirement listed above must have an associated method of demonstrating compliance. If there is not already a required method in place, then a method must be proposed.)

From current Title V permit:

Are you in compliance with all applicable requirements for this emission unit? Yes No

If no, complete the **Schedule of Compliance Form** as ATTACHMENT F.

ATTACHMENT E - Emission Unit Form

Emission Unit Description: *Storage Tank*

Emission unit ID number: 9656	Emission unit name: Tank 9656	List any control devices associated with this emission unit: N/A
---	---	--

Provide a description of the emission unit (type, method of operation, design parameters, etc.):
Storage tank.

Manufacturer:	Model number:	Serial number:
----------------------	----------------------	-----------------------

Construction date: See Attachment D Equipment Table	Installation date: See Attachment D Equipment Table	Modification date(s): See Attachment D Equipment Table
---	---	--

Design Capacity (examples: furnaces - tons/hr, tanks - gallons): See Attachment D Equipment Table

Maximum Hourly Throughput:	Maximum Annual Throughput:	Maximum Operating Schedule: 24 hrs/day, 365 days/yr
-----------------------------------	-----------------------------------	---

Fuel Usage Data (fill out all applicable fields)

Does this emission unit combust fuel? ___Yes ___X___ No	If yes, is it? ___ Indirect Fired ___ Direct Fired
--	--

Maximum design heat input and/or maximum horsepower rating:	Type and Btu/hr rating of burners:
--	---

List the primary fuel type(s) and if applicable, the secondary fuel type(s). For each fuel type listed, provide the maximum hourly and annual fuel usage for each.

Describe each fuel expected to be used during the term of the permit.

Fuel Type	Max. Sulfur Content	Max. Ash Content	BTU Value

<i>Emissions Data</i>		
Criteria Pollutants	Potential Emissions	
	PPH	TPY
Carbon Monoxide (CO)		
Nitrogen Oxides (NO _x)		
Lead (Pb)		
Particulate Matter (PM _{2.5})		
Particulate Matter (PM ₁₀)		
Total Particulate Matter (TSP)		
Sulfur Dioxide (SO ₂)		
Volatile Organic Compounds (VOC)		
Hazardous Air Pollutants	Potential Emissions	
	PPH	TPY
Regulated Pollutants other than Criteria and HAP	Potential Emissions	
	PPH	TPY

List the method(s) used to calculate the potential emissions (include dates of any stack tests conducted, versions of software used, source and dates of emission factors, etc.).

Applicable Requirements

List all applicable requirements for this emission unit. For each applicable requirement, include the underlying rule/regulation citation and/or construction permit with the condition number. (Note: Title V permit condition numbers alone are not the underlying applicable requirements). If an emission limit is calculated based on the type of source and design capacity or if a standard is based on a design parameter, this information should also be included.

From current Title V permit:

____ Permit Shield

For all applicable requirements listed above, provide monitoring/testing/recordkeeping/reporting which shall be used to demonstrate compliance. If the method is based on a permit or rule, include the condition number or citation. (Note: Each requirement listed above must have an associated method of demonstrating compliance. If there is not already a required method in place, then a method must be proposed.)

From current Title V permit:

Are you in compliance with all applicable requirements for this emission unit? Yes No

If no, complete the **Schedule of Compliance Form** as ATTACHMENT F.

ATTACHMENT E - Emission Unit Form

Emission Unit Description: *Storage Tank*

Emission unit ID number: 9657	Emission unit name: Tank 9657	List any control devices associated with this emission unit: N/A
---	---	--

Provide a description of the emission unit (type, method of operation, design parameters, etc.):
Storage tank.

Manufacturer:	Model number:	Serial number:
----------------------	----------------------	-----------------------

Construction date: See Attachment D Equipment Table	Installation date: See Attachment D Equipment Table	Modification date(s): See Attachment D Equipment Table
---	---	--

Design Capacity (examples: furnaces - tons/hr, tanks - gallons): See Attachment D Equipment Table

Maximum Hourly Throughput:	Maximum Annual Throughput:	Maximum Operating Schedule: 24 hrs/day, 365 days/yr
-----------------------------------	-----------------------------------	---

Fuel Usage Data (fill out all applicable fields)

Does this emission unit combust fuel? <input type="checkbox"/> Yes <input checked="" type="checkbox"/> No	If yes, is it? <input type="checkbox"/> Indirect Fired <input type="checkbox"/> Direct Fired
--	--

Maximum design heat input and/or maximum horsepower rating:	Type and Btu/hr rating of burners:
--	---

List the primary fuel type(s) and if applicable, the secondary fuel type(s). For each fuel type listed, provide the maximum hourly and annual fuel usage for each.

Describe each fuel expected to be used during the term of the permit.

Fuel Type	Max. Sulfur Content	Max. Ash Content	BTU Value

<i>Emissions Data</i>		
Criteria Pollutants	Potential Emissions	
	PPH	TPY
Carbon Monoxide (CO)		
Nitrogen Oxides (NO _x)		
Lead (Pb)		
Particulate Matter (PM _{2.5})		
Particulate Matter (PM ₁₀)		
Total Particulate Matter (TSP)		
Sulfur Dioxide (SO ₂)		
Volatile Organic Compounds (VOC)		
Hazardous Air Pollutants	Potential Emissions	
	PPH	TPY
Regulated Pollutants other than Criteria and HAP	Potential Emissions	
	PPH	TPY

List the method(s) used to calculate the potential emissions (include dates of any stack tests conducted, versions of software used, source and dates of emission factors, etc.).

Applicable Requirements

List all applicable requirements for this emission unit. For each applicable requirement, include the underlying rule/regulation citation and/or construction permit with the condition number. (Note: Title V permit condition numbers alone are not the underlying applicable requirements). If an emission limit is calculated based on the type of source and design capacity or if a standard is based on a design parameter, this information should also be included.

From current Title V permit:

____ Permit Shield

For all applicable requirements listed above, provide monitoring/testing/recordkeeping/reporting which shall be used to demonstrate compliance. If the method is based on a permit or rule, include the condition number or citation. (Note: Each requirement listed above must have an associated method of demonstrating compliance. If there is not already a required method in place, then a method must be proposed.)

From current Title V permit:

Are you in compliance with all applicable requirements for this emission unit? Yes No

If no, complete the **Schedule of Compliance Form** as ATTACHMENT F.

ATTACHMENT E - Emission Unit Form

Emission Unit Description: *Storage Tank*

Emission unit ID number: 9732	Emission unit name: Tank 9732	List any control devices associated with this emission unit: N/A
---	---	--

Provide a description of the emission unit (type, method of operation, design parameters, etc.):
Storage tank.

Manufacturer:	Model number:	Serial number:
----------------------	----------------------	-----------------------

Construction date: See Attachment D Equipment Table	Installation date: See Attachment D Equipment Table	Modification date(s): See Attachment D Equipment Table
---	---	--

Design Capacity (examples: furnaces - tons/hr, tanks - gallons): See Attachment D Equipment Table

Maximum Hourly Throughput:	Maximum Annual Throughput:	Maximum Operating Schedule: 24 hrs/day, 365 days/yr
-----------------------------------	-----------------------------------	---

Fuel Usage Data (fill out all applicable fields)

Does this emission unit combust fuel? <input type="checkbox"/> Yes <input checked="" type="checkbox"/> No	If yes, is it? <input type="checkbox"/> Indirect Fired <input type="checkbox"/> Direct Fired
--	--

Maximum design heat input and/or maximum horsepower rating:	Type and Btu/hr rating of burners:
--	---

List the primary fuel type(s) and if applicable, the secondary fuel type(s). For each fuel type listed, provide the maximum hourly and annual fuel usage for each.

Describe each fuel expected to be used during the term of the permit.

Fuel Type	Max. Sulfur Content	Max. Ash Content	BTU Value

<i>Emissions Data</i>		
Criteria Pollutants	Potential Emissions	
	PPH	TPY
Carbon Monoxide (CO)		
Nitrogen Oxides (NO _x)		
Lead (Pb)		
Particulate Matter (PM _{2.5})		
Particulate Matter (PM ₁₀)		
Total Particulate Matter (TSP)		
Sulfur Dioxide (SO ₂)		
Volatile Organic Compounds (VOC)		
Hazardous Air Pollutants	Potential Emissions	
	PPH	TPY
Regulated Pollutants other than Criteria and HAP	Potential Emissions	
	PPH	TPY

List the method(s) used to calculate the potential emissions (include dates of any stack tests conducted, versions of software used, source and dates of emission factors, etc.).

Applicable Requirements

List all applicable requirements for this emission unit. For each applicable requirement, include the underlying rule/regulation citation and/or construction permit with the condition number. (Note: Title V permit condition numbers alone are not the underlying applicable requirements). If an emission limit is calculated based on the type of source and design capacity or if a standard is based on a design parameter, this information should also be included.

From current Title V permit:

____ Permit Shield

For all applicable requirements listed above, provide monitoring/testing/recordkeeping/reporting which shall be used to demonstrate compliance. If the method is based on a permit or rule, include the condition number or citation. (Note: Each requirement listed above must have an associated method of demonstrating compliance. If there is not already a required method in place, then a method must be proposed.)

From current Title V permit:

Are you in compliance with all applicable requirements for this emission unit? Yes No

If no, complete the **Schedule of Compliance Form** as ATTACHMENT F.

ATTACHMENT E - Emission Unit Form

Emission Unit Description: *Storage Tank*

Emission unit ID number: 9733	Emission unit name: Tank 9733	List any control devices associated with this emission unit: N/A
---	---	--

Provide a description of the emission unit (type, method of operation, design parameters, etc.):
Storage tank.

Manufacturer:	Model number:	Serial number:
----------------------	----------------------	-----------------------

Construction date: See Attachment D Equipment Table	Installation date: See Attachment D Equipment Table	Modification date(s): See Attachment D Equipment Table
---	---	--

Design Capacity (examples: furnaces - tons/hr, tanks - gallons): See Attachment D Equipment Table

Maximum Hourly Throughput:	Maximum Annual Throughput:	Maximum Operating Schedule: 24 hrs/day, 365 days/yr
-----------------------------------	-----------------------------------	---

Fuel Usage Data (fill out all applicable fields)

Does this emission unit combust fuel? ___Yes ___X___ No	If yes, is it? ___ Indirect Fired ___ Direct Fired
--	--

Maximum design heat input and/or maximum horsepower rating:	Type and Btu/hr rating of burners:
--	---

List the primary fuel type(s) and if applicable, the secondary fuel type(s). For each fuel type listed, provide the maximum hourly and annual fuel usage for each.

Describe each fuel expected to be used during the term of the permit.

Fuel Type	Max. Sulfur Content	Max. Ash Content	BTU Value

<i>Emissions Data</i>		
Criteria Pollutants	Potential Emissions	
	PPH	TPY
Carbon Monoxide (CO)		
Nitrogen Oxides (NO _x)		
Lead (Pb)		
Particulate Matter (PM _{2.5})		
Particulate Matter (PM ₁₀)		
Total Particulate Matter (TSP)		
Sulfur Dioxide (SO ₂)		
Volatile Organic Compounds (VOC)		
Hazardous Air Pollutants	Potential Emissions	
	PPH	TPY
Regulated Pollutants other than Criteria and HAP	Potential Emissions	
	PPH	TPY

List the method(s) used to calculate the potential emissions (include dates of any stack tests conducted, versions of software used, source and dates of emission factors, etc.).

Applicable Requirements

List all applicable requirements for this emission unit. For each applicable requirement, include the underlying rule/regulation citation and/or construction permit with the condition number. (Note: Title V permit condition numbers alone are not the underlying applicable requirements). If an emission limit is calculated based on the type of source and design capacity or if a standard is based on a design parameter, this information should also be included.

From current Title V permit:

____ Permit Shield

For all applicable requirements listed above, provide monitoring/testing/recordkeeping/reporting which shall be used to demonstrate compliance. If the method is based on a permit or rule, include the condition number or citation. (Note: Each requirement listed above must have an associated method of demonstrating compliance. If there is not already a required method in place, then a method must be proposed.)

From current Title V permit:

Are you in compliance with all applicable requirements for this emission unit? Yes No

If no, complete the **Schedule of Compliance Form** as ATTACHMENT F.

ATTACHMENT E - Emission Unit Form

Emission Unit Description: *Storage Tank*

Emission unit ID number: 9734	Emission unit name: Tank 9734	List any control devices associated with this emission unit: N/A
---	---	--

Provide a description of the emission unit (type, method of operation, design parameters, etc.):
Storage tank.

Manufacturer:	Model number:	Serial number:
----------------------	----------------------	-----------------------

Construction date: See Attachment D Equipment Table	Installation date: See Attachment D Equipment Table	Modification date(s): See Attachment D Equipment Table
---	---	--

Design Capacity (examples: furnaces - tons/hr, tanks - gallons): See Attachment D Equipment Table

Maximum Hourly Throughput:	Maximum Annual Throughput:	Maximum Operating Schedule: 24 hrs/day, 365 days/yr
-----------------------------------	-----------------------------------	---

Fuel Usage Data (fill out all applicable fields)

Does this emission unit combust fuel? <input type="checkbox"/> Yes <input checked="" type="checkbox"/> No	If yes, is it? <input type="checkbox"/> Indirect Fired <input type="checkbox"/> Direct Fired
--	--

Maximum design heat input and/or maximum horsepower rating:	Type and Btu/hr rating of burners:
--	---

List the primary fuel type(s) and if applicable, the secondary fuel type(s). For each fuel type listed, provide the maximum hourly and annual fuel usage for each.

Describe each fuel expected to be used during the term of the permit.

Fuel Type	Max. Sulfur Content	Max. Ash Content	BTU Value

<i>Emissions Data</i>		
Criteria Pollutants	Potential Emissions	
	PPH	TPY
Carbon Monoxide (CO)		
Nitrogen Oxides (NO _x)		
Lead (Pb)		
Particulate Matter (PM _{2.5})		
Particulate Matter (PM ₁₀)		
Total Particulate Matter (TSP)		
Sulfur Dioxide (SO ₂)		
Volatile Organic Compounds (VOC)		
Hazardous Air Pollutants	Potential Emissions	
	PPH	TPY
Regulated Pollutants other than Criteria and HAP	Potential Emissions	
	PPH	TPY

List the method(s) used to calculate the potential emissions (include dates of any stack tests conducted, versions of software used, source and dates of emission factors, etc.).

Applicable Requirements

List all applicable requirements for this emission unit. For each applicable requirement, include the underlying rule/regulation citation and/or construction permit with the condition number. (Note: Title V permit condition numbers alone are not the underlying applicable requirements). If an emission limit is calculated based on the type of source and design capacity or if a standard is based on a design parameter, this information should also be included.

From current Title V permit:

____ Permit Shield

For all applicable requirements listed above, provide monitoring/testing/recordkeeping/reporting which shall be used to demonstrate compliance. If the method is based on a permit or rule, include the condition number or citation. (Note: Each requirement listed above must have an associated method of demonstrating compliance. If there is not already a required method in place, then a method must be proposed.)

From current Title V permit:

Are you in compliance with all applicable requirements for this emission unit? Yes No

If no, complete the **Schedule of Compliance Form** as ATTACHMENT F.

ATTACHMENT E - Emission Unit Form

Emission Unit Description: *Storage Tank*

Emission unit ID number: 9735	Emission unit name: Tank 9735	List any control devices associated with this emission unit: N/A
---	---	--

Provide a description of the emission unit (type, method of operation, design parameters, etc.):
Storage tank.

Manufacturer:	Model number:	Serial number:
----------------------	----------------------	-----------------------

Construction date: See Attachment D Equipment Table	Installation date: See Attachment D Equipment Table	Modification date(s): See Attachment D Equipment Table
---	---	--

Design Capacity (examples: furnaces - tons/hr, tanks - gallons): See Attachment D Equipment Table

Maximum Hourly Throughput:	Maximum Annual Throughput:	Maximum Operating Schedule: 24 hrs/day, 365 days/yr
-----------------------------------	-----------------------------------	---

Fuel Usage Data (fill out all applicable fields)

Does this emission unit combust fuel? ___Yes ___X___ No	If yes, is it? ___ Indirect Fired ___ Direct Fired
--	--

Maximum design heat input and/or maximum horsepower rating:	Type and Btu/hr rating of burners:
--	---

List the primary fuel type(s) and if applicable, the secondary fuel type(s). For each fuel type listed, provide the maximum hourly and annual fuel usage for each.

Describe each fuel expected to be used during the term of the permit.

Fuel Type	Max. Sulfur Content	Max. Ash Content	BTU Value

<i>Emissions Data</i>		
Criteria Pollutants	Potential Emissions	
	PPH	TPY
Carbon Monoxide (CO)		
Nitrogen Oxides (NO _x)		
Lead (Pb)		
Particulate Matter (PM _{2.5})		
Particulate Matter (PM ₁₀)		
Total Particulate Matter (TSP)		
Sulfur Dioxide (SO ₂)		
Volatile Organic Compounds (VOC)		
Hazardous Air Pollutants	Potential Emissions	
	PPH	TPY
Regulated Pollutants other than Criteria and HAP	Potential Emissions	
	PPH	TPY

List the method(s) used to calculate the potential emissions (include dates of any stack tests conducted, versions of software used, source and dates of emission factors, etc.).

Applicable Requirements

List all applicable requirements for this emission unit. For each applicable requirement, include the underlying rule/regulation citation and/or construction permit with the condition number. (Note: Title V permit condition numbers alone are not the underlying applicable requirements). If an emission limit is calculated based on the type of source and design capacity or if a standard is based on a design parameter, this information should also be included.

From current Title V permit:

____ Permit Shield

For all applicable requirements listed above, provide monitoring/testing/recordkeeping/reporting which shall be used to demonstrate compliance. If the method is based on a permit or rule, include the condition number or citation. (Note: Each requirement listed above must have an associated method of demonstrating compliance. If there is not already a required method in place, then a method must be proposed.)

From current Title V permit:

Are you in compliance with all applicable requirements for this emission unit? Yes No

If no, complete the **Schedule of Compliance Form** as ATTACHMENT F.

ATTACHMENT E - Emission Unit Form

Emission Unit Description: *Storage Tank*

Emission unit ID number: 9736	Emission unit name: Tank 9736	List any control devices associated with this emission unit: N/A
---	---	--

Provide a description of the emission unit (type, method of operation, design parameters, etc.):
Storage tank.

Manufacturer:	Model number:	Serial number:
----------------------	----------------------	-----------------------

Construction date: See Attachment D Equipment Table	Installation date: See Attachment D Equipment Table	Modification date(s): See Attachment D Equipment Table
---	---	--

Design Capacity (examples: furnaces - tons/hr, tanks - gallons): See Attachment D Equipment Table

Maximum Hourly Throughput:	Maximum Annual Throughput:	Maximum Operating Schedule: 24 hrs/day, 365 days/yr
-----------------------------------	-----------------------------------	---

Fuel Usage Data (fill out all applicable fields)

Does this emission unit combust fuel? <input type="checkbox"/> Yes <input checked="" type="checkbox"/> No	If yes, is it? <input type="checkbox"/> Indirect Fired <input type="checkbox"/> Direct Fired
--	--

Maximum design heat input and/or maximum horsepower rating:	Type and Btu/hr rating of burners:
--	---

List the primary fuel type(s) and if applicable, the secondary fuel type(s). For each fuel type listed, provide the maximum hourly and annual fuel usage for each.

Describe each fuel expected to be used during the term of the permit.

Fuel Type	Max. Sulfur Content	Max. Ash Content	BTU Value

<i>Emissions Data</i>		
Criteria Pollutants	Potential Emissions	
	PPH	TPY
Carbon Monoxide (CO)		
Nitrogen Oxides (NO _x)		
Lead (Pb)		
Particulate Matter (PM _{2.5})		
Particulate Matter (PM ₁₀)		
Total Particulate Matter (TSP)		
Sulfur Dioxide (SO ₂)		
Volatile Organic Compounds (VOC)		
Hazardous Air Pollutants	Potential Emissions	
	PPH	TPY
Regulated Pollutants other than Criteria and HAP	Potential Emissions	
	PPH	TPY

List the method(s) used to calculate the potential emissions (include dates of any stack tests conducted, versions of software used, source and dates of emission factors, etc.).

Applicable Requirements

List all applicable requirements for this emission unit. For each applicable requirement, include the underlying rule/regulation citation and/or construction permit with the condition number. (Note: Title V permit condition numbers alone are not the underlying applicable requirements). If an emission limit is calculated based on the type of source and design capacity or if a standard is based on a design parameter, this information should also be included.

From current Title V permit:

____ Permit Shield

For all applicable requirements listed above, provide monitoring/testing/recordkeeping/reporting which shall be used to demonstrate compliance. If the method is based on a permit or rule, include the condition number or citation. (Note: Each requirement listed above must have an associated method of demonstrating compliance. If there is not already a required method in place, then a method must be proposed.)

From current Title V permit:

Are you in compliance with all applicable requirements for this emission unit? Yes No

If no, complete the **Schedule of Compliance Form** as ATTACHMENT F.

ATTACHMENT E - Emission Unit Form

Emission Unit Description: *Storage Tank*

Emission unit ID number: 9738	Emission unit name: Tank 9738	List any control devices associated with this emission unit: N/A
---	---	--

Provide a description of the emission unit (type, method of operation, design parameters, etc.):

Storage tank.

Manufacturer:	Model number:	Serial number:
----------------------	----------------------	-----------------------

Construction date: See Attachment D Equipment Table	Installation date: See Attachment D Equipment Table	Modification date(s): See Attachment D Equipment Table
---	---	--

Design Capacity (examples: furnaces - tons/hr, tanks - gallons): See Attachment D Equipment Table

Maximum Hourly Throughput:	Maximum Annual Throughput:	Maximum Operating Schedule: 24 hrs/day, 365 days/yr
-----------------------------------	-----------------------------------	---

Fuel Usage Data (fill out all applicable fields)

Does this emission unit combust fuel? ___Yes ___X___ No	If yes, is it? ___ Indirect Fired ___ Direct Fired
--	--

Maximum design heat input and/or maximum horsepower rating:	Type and Btu/hr rating of burners:
--	---

List the primary fuel type(s) and if applicable, the secondary fuel type(s). For each fuel type listed, provide the maximum hourly and annual fuel usage for each.

Describe each fuel expected to be used during the term of the permit.

Fuel Type	Max. Sulfur Content	Max. Ash Content	BTU Value

<i>Emissions Data</i>		
Criteria Pollutants	Potential Emissions	
	PPH	TPY
Carbon Monoxide (CO)		
Nitrogen Oxides (NO _x)		
Lead (Pb)		
Particulate Matter (PM _{2.5})		
Particulate Matter (PM ₁₀)		
Total Particulate Matter (TSP)		
Sulfur Dioxide (SO ₂)		
Volatile Organic Compounds (VOC)		
Hazardous Air Pollutants	Potential Emissions	
	PPH	TPY
Regulated Pollutants other than Criteria and HAP	Potential Emissions	
	PPH	TPY

List the method(s) used to calculate the potential emissions (include dates of any stack tests conducted, versions of software used, source and dates of emission factors, etc.).

Applicable Requirements

List all applicable requirements for this emission unit. For each applicable requirement, include the underlying rule/regulation citation and/or construction permit with the condition number. (Note: Title V permit condition numbers alone are not the underlying applicable requirements). If an emission limit is calculated based on the type of source and design capacity or if a standard is based on a design parameter, this information should also be included.

From current Title V permit:

____ Permit Shield

For all applicable requirements listed above, provide monitoring/testing/recordkeeping/reporting which shall be used to demonstrate compliance. If the method is based on a permit or rule, include the condition number or citation. (Note: Each requirement listed above must have an associated method of demonstrating compliance. If there is not already a required method in place, then a method must be proposed.)

From current Title V permit:

Are you in compliance with all applicable requirements for this emission unit? Yes No

If no, complete the **Schedule of Compliance Form** as ATTACHMENT F.

ATTACHMENT E - Emission Unit Form

Emission Unit Description: *Storage Tank*

Emission unit ID number: 9740	Emission unit name: Tank 9740	List any control devices associated with this emission unit: N/A
---	---	--

Provide a description of the emission unit (type, method of operation, design parameters, etc.):
Storage tank.

Manufacturer:	Model number:	Serial number:
----------------------	----------------------	-----------------------

Construction date: See Attachment D Equipment Table	Installation date: See Attachment D Equipment Table	Modification date(s): See Attachment D Equipment Table
---	---	--

Design Capacity (examples: furnaces - tons/hr, tanks - gallons): See Attachment D Equipment Table

Maximum Hourly Throughput:	Maximum Annual Throughput:	Maximum Operating Schedule: 24 hrs/day, 365 days/yr
-----------------------------------	-----------------------------------	---

Fuel Usage Data (fill out all applicable fields)

Does this emission unit combust fuel? ___Yes ___X___ No	If yes, is it? ___ Indirect Fired ___ Direct Fired
--	--

Maximum design heat input and/or maximum horsepower rating:	Type and Btu/hr rating of burners:
--	---

List the primary fuel type(s) and if applicable, the secondary fuel type(s). For each fuel type listed, provide the maximum hourly and annual fuel usage for each.

Describe each fuel expected to be used during the term of the permit.

Fuel Type	Max. Sulfur Content	Max. Ash Content	BTU Value

<i>Emissions Data</i>		
Criteria Pollutants	Potential Emissions	
	PPH	TPY
Carbon Monoxide (CO)		
Nitrogen Oxides (NO _x)		
Lead (Pb)		
Particulate Matter (PM _{2.5})		
Particulate Matter (PM ₁₀)		
Total Particulate Matter (TSP)		
Sulfur Dioxide (SO ₂)		
Volatile Organic Compounds (VOC)		
Hazardous Air Pollutants	Potential Emissions	
	PPH	TPY
Regulated Pollutants other than Criteria and HAP	Potential Emissions	
	PPH	TPY

List the method(s) used to calculate the potential emissions (include dates of any stack tests conducted, versions of software used, source and dates of emission factors, etc.).

Applicable Requirements

List all applicable requirements for this emission unit. For each applicable requirement, include the underlying rule/regulation citation and/or construction permit with the condition number. (Note: Title V permit condition numbers alone are not the underlying applicable requirements). If an emission limit is calculated based on the type of source and design capacity or if a standard is based on a design parameter, this information should also be included.

From current Title V permit:

____ Permit Shield

For all applicable requirements listed above, provide monitoring/testing/recordkeeping/reporting which shall be used to demonstrate compliance. If the method is based on a permit or rule, include the condition number or citation. (Note: Each requirement listed above must have an associated method of demonstrating compliance. If there is not already a required method in place, then a method must be proposed.)

From current Title V permit:

Are you in compliance with all applicable requirements for this emission unit? Yes No

If no, complete the **Schedule of Compliance Form** as ATTACHMENT F.

ATTACHMENT E - Emission Unit Form

Emission Unit Description: *Storage Tank*

Emission unit ID number: 9749	Emission unit name: Tank 9749	List any control devices associated with this emission unit: N/A
---	---	--

Provide a description of the emission unit (type, method of operation, design parameters, etc.):
Storage tank.

Manufacturer:	Model number:	Serial number:
----------------------	----------------------	-----------------------

Construction date: See Attachment D Equipment Table	Installation date: See Attachment D Equipment Table	Modification date(s): See Attachment D Equipment Table
---	---	--

Design Capacity (examples: furnaces - tons/hr, tanks - gallons): See Attachment D Equipment Table

Maximum Hourly Throughput:	Maximum Annual Throughput:	Maximum Operating Schedule: 24 hrs/day, 365 days/yr
-----------------------------------	-----------------------------------	---

Fuel Usage Data (fill out all applicable fields)

Does this emission unit combust fuel? <input type="checkbox"/> Yes <input checked="" type="checkbox"/> No	If yes, is it? <input type="checkbox"/> Indirect Fired <input type="checkbox"/> Direct Fired
--	--

Maximum design heat input and/or maximum horsepower rating:	Type and Btu/hr rating of burners:
--	---

List the primary fuel type(s) and if applicable, the secondary fuel type(s). For each fuel type listed, provide the maximum hourly and annual fuel usage for each.

Describe each fuel expected to be used during the term of the permit.

Fuel Type	Max. Sulfur Content	Max. Ash Content	BTU Value

<i>Emissions Data</i>		
Criteria Pollutants	Potential Emissions	
	PPH	TPY
Carbon Monoxide (CO)		
Nitrogen Oxides (NO _x)		
Lead (Pb)		
Particulate Matter (PM _{2.5})		
Particulate Matter (PM ₁₀)		
Total Particulate Matter (TSP)		
Sulfur Dioxide (SO ₂)		
Volatile Organic Compounds (VOC)		
Hazardous Air Pollutants	Potential Emissions	
	PPH	TPY
Regulated Pollutants other than Criteria and HAP	Potential Emissions	
	PPH	TPY

List the method(s) used to calculate the potential emissions (include dates of any stack tests conducted, versions of software used, source and dates of emission factors, etc.).

Applicable Requirements

List all applicable requirements for this emission unit. For each applicable requirement, include the underlying rule/regulation citation and/or construction permit with the condition number. (Note: Title V permit condition numbers alone are not the underlying applicable requirements). If an emission limit is calculated based on the type of source and design capacity or if a standard is based on a design parameter, this information should also be included.

From current Title V permit:

____ Permit Shield

For all applicable requirements listed above, provide monitoring/testing/recordkeeping/reporting which shall be used to demonstrate compliance. If the method is based on a permit or rule, include the condition number or citation. (Note: Each requirement listed above must have an associated method of demonstrating compliance. If there is not already a required method in place, then a method must be proposed.)

From current Title V permit:

Are you in compliance with all applicable requirements for this emission unit? Yes No

If no, complete the **Schedule of Compliance Form** as ATTACHMENT F.

ATTACHMENT E - Emission Unit Form

Emission Unit Description: *Storage Tank*

Emission unit ID number: 9750	Emission unit name: Tank 9750	List any control devices associated with this emission unit: N/A
---	---	--

Provide a description of the emission unit (type, method of operation, design parameters, etc.):
Storage tank – sulfuric acid.

Manufacturer:	Model number:	Serial number:
----------------------	----------------------	-----------------------

Construction date: See Attachment D Equipment Table	Installation date: See Attachment D Equipment Table	Modification date(s): See Attachment D Equipment Table
---	---	--

Design Capacity (examples: furnaces - tons/hr, tanks - gallons): See Attachment D Equipment Table

Maximum Hourly Throughput:	Maximum Annual Throughput:	Maximum Operating Schedule: 24 hrs/day, 365 days/yr
-----------------------------------	-----------------------------------	---

Fuel Usage Data (fill out all applicable fields)

Does this emission unit combust fuel? ___Yes ___X___ No	If yes, is it? ___ Indirect Fired ___ Direct Fired
--	--

Maximum design heat input and/or maximum horsepower rating:	Type and Btu/hr rating of burners:
--	---

List the primary fuel type(s) and if applicable, the secondary fuel type(s). For each fuel type listed, provide the maximum hourly and annual fuel usage for each.

Describe each fuel expected to be used during the term of the permit.

Fuel Type	Max. Sulfur Content	Max. Ash Content	BTU Value

<i>Emissions Data</i>		
Criteria Pollutants	Potential Emissions	
	PPH	TPY
Carbon Monoxide (CO)		
Nitrogen Oxides (NO _x)		
Lead (Pb)		
Particulate Matter (PM _{2.5})		
Particulate Matter (PM ₁₀)		
Total Particulate Matter (TSP)		
Sulfur Dioxide (SO ₂)		
Volatile Organic Compounds (VOC)		
Hazardous Air Pollutants	Potential Emissions	
	PPH	TPY
Regulated Pollutants other than Criteria and HAP	Potential Emissions	
	PPH	TPY

List the method(s) used to calculate the potential emissions (include dates of any stack tests conducted, versions of software used, source and dates of emission factors, etc.).

Applicable Requirements

List all applicable requirements for this emission unit. For each applicable requirement, include the underlying rule/regulation citation and/or construction permit with the condition number. (Note: Title V permit condition numbers alone are not the underlying applicable requirements). If an emission limit is calculated based on the type of source and design capacity or if a standard is based on a design parameter, this information should also be included.

From current Title V permit:

____ Permit Shield

For all applicable requirements listed above, provide monitoring/testing/recordkeeping/reporting which shall be used to demonstrate compliance. If the method is based on a permit or rule, include the condition number or citation. (Note: Each requirement listed above must have an associated method of demonstrating compliance. If there is not already a required method in place, then a method must be proposed.)

From current Title V permit:

Are you in compliance with all applicable requirements for this emission unit? Yes No

If no, complete the **Schedule of Compliance Form** as ATTACHMENT F.

ATTACHMENT E - Emission Unit Form

Emission Unit Description: *Storage Tank*

Emission unit ID number: 9751	Emission unit name: Tank 9751	List any control devices associated with this emission unit: N/A
---	---	--

Provide a description of the emission unit (type, method of operation, design parameters, etc.):
Storage tank.

Manufacturer:	Model number:	Serial number:
----------------------	----------------------	-----------------------

Construction date: See Attachment D Equipment Table	Installation date: See Attachment D Equipment Table	Modification date(s): See Attachment D Equipment Table
---	---	--

Design Capacity (examples: furnaces - tons/hr, tanks - gallons): See Attachment D Equipment Table

Maximum Hourly Throughput:	Maximum Annual Throughput:	Maximum Operating Schedule: 24 hrs/day, 365 days/yr
-----------------------------------	-----------------------------------	---

Fuel Usage Data (fill out all applicable fields)

Does this emission unit combust fuel? ___Yes ___X___ No	If yes, is it? ___ Indirect Fired ___ Direct Fired
--	--

Maximum design heat input and/or maximum horsepower rating:	Type and Btu/hr rating of burners:
--	---

List the primary fuel type(s) and if applicable, the secondary fuel type(s). For each fuel type listed, provide the maximum hourly and annual fuel usage for each.

Describe each fuel expected to be used during the term of the permit.

Fuel Type	Max. Sulfur Content	Max. Ash Content	BTU Value

<i>Emissions Data</i>		
Criteria Pollutants	Potential Emissions	
	PPH	TPY
Carbon Monoxide (CO)		
Nitrogen Oxides (NO _x)		
Lead (Pb)		
Particulate Matter (PM _{2.5})		
Particulate Matter (PM ₁₀)		
Total Particulate Matter (TSP)		
Sulfur Dioxide (SO ₂)		
Volatile Organic Compounds (VOC)		
Hazardous Air Pollutants	Potential Emissions	
	PPH	TPY
Regulated Pollutants other than Criteria and HAP	Potential Emissions	
	PPH	TPY

List the method(s) used to calculate the potential emissions (include dates of any stack tests conducted, versions of software used, source and dates of emission factors, etc.).

Applicable Requirements

List all applicable requirements for this emission unit. For each applicable requirement, include the underlying rule/regulation citation and/or construction permit with the condition number. (Note: Title V permit condition numbers alone are not the underlying applicable requirements). If an emission limit is calculated based on the type of source and design capacity or if a standard is based on a design parameter, this information should also be included.

From current Title V permit:

____ Permit Shield

For all applicable requirements listed above, provide monitoring/testing/recordkeeping/reporting which shall be used to demonstrate compliance. If the method is based on a permit or rule, include the condition number or citation. (Note: Each requirement listed above must have an associated method of demonstrating compliance. If there is not already a required method in place, then a method must be proposed.)

From current Title V permit:

Are you in compliance with all applicable requirements for this emission unit? Yes No

If no, complete the **Schedule of Compliance Form** as ATTACHMENT F.

ATTACHMENT E - Emission Unit Form

Emission Unit Description: *Storage Tank*

Emission unit ID number: 9752	Emission unit name: Tank 9752	List any control devices associated with this emission unit: N/A
---	---	--

Provide a description of the emission unit (type, method of operation, design parameters, etc.):
Storage tank.

Manufacturer:	Model number:	Serial number:
----------------------	----------------------	-----------------------

Construction date: See Attachment D Equipment Table	Installation date: See Attachment D Equipment Table	Modification date(s): See Attachment D Equipment Table
---	---	--

Design Capacity (examples: furnaces - tons/hr, tanks - gallons): See Attachment D Equipment Table

Maximum Hourly Throughput:	Maximum Annual Throughput:	Maximum Operating Schedule: 24 hrs/day, 365 days/yr
-----------------------------------	-----------------------------------	---

Fuel Usage Data (fill out all applicable fields)

Does this emission unit combust fuel? <input type="checkbox"/> Yes <input checked="" type="checkbox"/> No	If yes, is it? <input type="checkbox"/> Indirect Fired <input type="checkbox"/> Direct Fired
--	--

Maximum design heat input and/or maximum horsepower rating:	Type and Btu/hr rating of burners:
--	---

List the primary fuel type(s) and if applicable, the secondary fuel type(s). For each fuel type listed, provide the maximum hourly and annual fuel usage for each.

Describe each fuel expected to be used during the term of the permit.

Fuel Type	Max. Sulfur Content	Max. Ash Content	BTU Value

<i>Emissions Data</i>		
Criteria Pollutants	Potential Emissions	
	PPH	TPY
Carbon Monoxide (CO)		
Nitrogen Oxides (NO _x)		
Lead (Pb)		
Particulate Matter (PM _{2.5})		
Particulate Matter (PM ₁₀)		
Total Particulate Matter (TSP)		
Sulfur Dioxide (SO ₂)		
Volatile Organic Compounds (VOC)		
Hazardous Air Pollutants	Potential Emissions	
	PPH	TPY
Regulated Pollutants other than Criteria and HAP	Potential Emissions	
	PPH	TPY

List the method(s) used to calculate the potential emissions (include dates of any stack tests conducted, versions of software used, source and dates of emission factors, etc.).

Applicable Requirements

List all applicable requirements for this emission unit. For each applicable requirement, include the underlying rule/regulation citation and/or construction permit with the condition number. (Note: Title V permit condition numbers alone are not the underlying applicable requirements). If an emission limit is calculated based on the type of source and design capacity or if a standard is based on a design parameter, this information should also be included.

From current Title V permit:

____ Permit Shield

For all applicable requirements listed above, provide monitoring/testing/recordkeeping/reporting which shall be used to demonstrate compliance. If the method is based on a permit or rule, include the condition number or citation. (Note: Each requirement listed above must have an associated method of demonstrating compliance. If there is not already a required method in place, then a method must be proposed.)

From current Title V permit:

Are you in compliance with all applicable requirements for this emission unit? Yes No

If no, complete the **Schedule of Compliance Form** as ATTACHMENT F.

ATTACHMENT E - Emission Unit Form

Emission Unit Description: *Storage Tank*

Emission unit ID number: 9756	Emission unit name: Tank 9756	List any control devices associated with this emission unit: N/A
---	---	--

Provide a description of the emission unit (type, method of operation, design parameters, etc.):
Storage tank.

Manufacturer:	Model number:	Serial number:
----------------------	----------------------	-----------------------

Construction date: See Attachment D Equipment Table	Installation date: See Attachment D Equipment Table	Modification date(s): See Attachment D Equipment Table
---	---	--

Design Capacity (examples: furnaces - tons/hr, tanks - gallons): See Attachment D Equipment Table

Maximum Hourly Throughput:	Maximum Annual Throughput:	Maximum Operating Schedule: 24 hrs/day, 365 days/yr
-----------------------------------	-----------------------------------	---

Fuel Usage Data (fill out all applicable fields)

Does this emission unit combust fuel? ___Yes ___X___ No	If yes, is it? ___ Indirect Fired ___ Direct Fired
--	--

Maximum design heat input and/or maximum horsepower rating:	Type and Btu/hr rating of burners:
--	---

List the primary fuel type(s) and if applicable, the secondary fuel type(s). For each fuel type listed, provide the maximum hourly and annual fuel usage for each.

Describe each fuel expected to be used during the term of the permit.

Fuel Type	Max. Sulfur Content	Max. Ash Content	BTU Value

<i>Emissions Data</i>		
Criteria Pollutants	Potential Emissions	
	PPH	TPY
Carbon Monoxide (CO)		
Nitrogen Oxides (NO _x)		
Lead (Pb)		
Particulate Matter (PM _{2.5})		
Particulate Matter (PM ₁₀)		
Total Particulate Matter (TSP)		
Sulfur Dioxide (SO ₂)		
Volatile Organic Compounds (VOC)		
Hazardous Air Pollutants	Potential Emissions	
	PPH	TPY
Regulated Pollutants other than Criteria and HAP	Potential Emissions	
	PPH	TPY

List the method(s) used to calculate the potential emissions (include dates of any stack tests conducted, versions of software used, source and dates of emission factors, etc.).

Applicable Requirements

List all applicable requirements for this emission unit. For each applicable requirement, include the underlying rule/regulation citation and/or construction permit with the condition number. (Note: Title V permit condition numbers alone are not the underlying applicable requirements). If an emission limit is calculated based on the type of source and design capacity or if a standard is based on a design parameter, this information should also be included.

From current Title V permit:

____ Permit Shield

For all applicable requirements listed above, provide monitoring/testing/recordkeeping/reporting which shall be used to demonstrate compliance. If the method is based on a permit or rule, include the condition number or citation. (Note: Each requirement listed above must have an associated method of demonstrating compliance. If there is not already a required method in place, then a method must be proposed.)

From current Title V permit:

Are you in compliance with all applicable requirements for this emission unit? Yes No

If no, complete the **Schedule of Compliance Form** as ATTACHMENT F.

ATTACHMENT E - Emission Unit Form

Emission Unit Description: *Storage Tank*

Emission unit ID number: 9757	Emission unit name: Tank 9757	List any control devices associated with this emission unit: N/A
---	---	--

Provide a description of the emission unit (type, method of operation, design parameters, etc.):
Storage tank.

Manufacturer:	Model number:	Serial number:
----------------------	----------------------	-----------------------

Construction date: See Attachment D Equipment Table	Installation date: See Attachment D Equipment Table	Modification date(s): See Attachment D Equipment Table
---	---	--

Design Capacity (examples: furnaces - tons/hr, tanks - gallons): See Attachment D Equipment Table

Maximum Hourly Throughput:	Maximum Annual Throughput:	Maximum Operating Schedule: 24 hrs/day, 365 days/yr
-----------------------------------	-----------------------------------	---

Fuel Usage Data (fill out all applicable fields)

Does this emission unit combust fuel? <input type="checkbox"/> Yes <input checked="" type="checkbox"/> No	If yes, is it? <input type="checkbox"/> Indirect Fired <input type="checkbox"/> Direct Fired
--	--

Maximum design heat input and/or maximum horsepower rating:	Type and Btu/hr rating of burners:
--	---

List the primary fuel type(s) and if applicable, the secondary fuel type(s). For each fuel type listed, provide the maximum hourly and annual fuel usage for each.

Describe each fuel expected to be used during the term of the permit.

Fuel Type	Max. Sulfur Content	Max. Ash Content	BTU Value

<i>Emissions Data</i>		
Criteria Pollutants	Potential Emissions	
	PPH	TPY
Carbon Monoxide (CO)		
Nitrogen Oxides (NO _x)		
Lead (Pb)		
Particulate Matter (PM _{2.5})		
Particulate Matter (PM ₁₀)		
Total Particulate Matter (TSP)		
Sulfur Dioxide (SO ₂)		
Volatile Organic Compounds (VOC)		
Hazardous Air Pollutants	Potential Emissions	
	PPH	TPY
Regulated Pollutants other than Criteria and HAP	Potential Emissions	
	PPH	TPY

List the method(s) used to calculate the potential emissions (include dates of any stack tests conducted, versions of software used, source and dates of emission factors, etc.).

Applicable Requirements

List all applicable requirements for this emission unit. For each applicable requirement, include the underlying rule/regulation citation and/or construction permit with the condition number. (Note: Title V permit condition numbers alone are not the underlying applicable requirements). If an emission limit is calculated based on the type of source and design capacity or if a standard is based on a design parameter, this information should also be included.

From current Title V permit:

____ Permit Shield

For all applicable requirements listed above, provide monitoring/testing/recordkeeping/reporting which shall be used to demonstrate compliance. If the method is based on a permit or rule, include the condition number or citation. (Note: Each requirement listed above must have an associated method of demonstrating compliance. If there is not already a required method in place, then a method must be proposed.)

From current Title V permit:

Are you in compliance with all applicable requirements for this emission unit? Yes No

If no, complete the **Schedule of Compliance Form** as ATTACHMENT F.

ATTACHMENT E - Emission Unit Form

Emission Unit Description: *Storage Tank*

Emission unit ID number: 9771	Emission unit name: Tank 9771	List any control devices associated with this emission unit: N/A
---	---	--

Provide a description of the emission unit (type, method of operation, design parameters, etc.):

Storage tank.

Manufacturer:	Model number:	Serial number:
----------------------	----------------------	-----------------------

Construction date: See Attachment D Equipment Table	Installation date: See Attachment D Equipment Table	Modification date(s): See Attachment D Equipment Table
---	---	--

Design Capacity (examples: furnaces - tons/hr, tanks - gallons): See Attachment D Equipment Table

Maximum Hourly Throughput:	Maximum Annual Throughput:	Maximum Operating Schedule: 24 hrs/day, 365 days/yr
-----------------------------------	-----------------------------------	---

Fuel Usage Data (fill out all applicable fields)

Does this emission unit combust fuel? ___Yes ___X___ No	If yes, is it? ___ Indirect Fired ___ Direct Fired
--	--

Maximum design heat input and/or maximum horsepower rating:	Type and Btu/hr rating of burners:
--	---

List the primary fuel type(s) and if applicable, the secondary fuel type(s). For each fuel type listed, provide the maximum hourly and annual fuel usage for each.

Describe each fuel expected to be used during the term of the permit.

Fuel Type	Max. Sulfur Content	Max. Ash Content	BTU Value

<i>Emissions Data</i>		
Criteria Pollutants	Potential Emissions	
	PPH	TPY
Carbon Monoxide (CO)		
Nitrogen Oxides (NO _x)		
Lead (Pb)		
Particulate Matter (PM _{2.5})		
Particulate Matter (PM ₁₀)		
Total Particulate Matter (TSP)		
Sulfur Dioxide (SO ₂)		
Volatile Organic Compounds (VOC)		
Hazardous Air Pollutants	Potential Emissions	
	PPH	TPY
Regulated Pollutants other than Criteria and HAP	Potential Emissions	
	PPH	TPY

List the method(s) used to calculate the potential emissions (include dates of any stack tests conducted, versions of software used, source and dates of emission factors, etc.).

Applicable Requirements

List all applicable requirements for this emission unit. For each applicable requirement, include the underlying rule/regulation citation and/or construction permit with the condition number. (Note: Title V permit condition numbers alone are not the underlying applicable requirements). If an emission limit is calculated based on the type of source and design capacity or if a standard is based on a design parameter, this information should also be included.

From current Title V permit:

____ Permit Shield

For all applicable requirements listed above, provide monitoring/testing/recordkeeping/reporting which shall be used to demonstrate compliance. If the method is based on a permit or rule, include the condition number or citation. (Note: Each requirement listed above must have an associated method of demonstrating compliance. If there is not already a required method in place, then a method must be proposed.)

From current Title V permit:

Are you in compliance with all applicable requirements for this emission unit? Yes No

If no, complete the **Schedule of Compliance Form** as ATTACHMENT F.

ATTACHMENT E - Emission Unit Form

Emission Unit Description: *Storage Tank*

Emission unit ID number: 9772	Emission unit name: Tank 9772	List any control devices associated with this emission unit: N/A
---	---	--

Provide a description of the emission unit (type, method of operation, design parameters, etc.):
Storage tank.

Manufacturer:	Model number:	Serial number:
----------------------	----------------------	-----------------------

Construction date: See Attachment D Equipment Table	Installation date: See Attachment D Equipment Table	Modification date(s): See Attachment D Equipment Table
---	---	--

Design Capacity (examples: furnaces - tons/hr, tanks - gallons): See Attachment D Equipment Table

Maximum Hourly Throughput:	Maximum Annual Throughput:	Maximum Operating Schedule: 24 hrs/day, 365 days/yr
-----------------------------------	-----------------------------------	---

Fuel Usage Data (fill out all applicable fields)

Does this emission unit combust fuel? <input type="checkbox"/> Yes <input checked="" type="checkbox"/> No	If yes, is it? <input type="checkbox"/> Indirect Fired <input type="checkbox"/> Direct Fired
--	--

Maximum design heat input and/or maximum horsepower rating:	Type and Btu/hr rating of burners:
--	---

List the primary fuel type(s) and if applicable, the secondary fuel type(s). For each fuel type listed, provide the maximum hourly and annual fuel usage for each.

Describe each fuel expected to be used during the term of the permit.

Fuel Type	Max. Sulfur Content	Max. Ash Content	BTU Value

<i>Emissions Data</i>		
Criteria Pollutants	Potential Emissions	
	PPH	TPY
Carbon Monoxide (CO)		
Nitrogen Oxides (NO _x)		
Lead (Pb)		
Particulate Matter (PM _{2.5})		
Particulate Matter (PM ₁₀)		
Total Particulate Matter (TSP)		
Sulfur Dioxide (SO ₂)		
Volatile Organic Compounds (VOC)		
Hazardous Air Pollutants	Potential Emissions	
	PPH	TPY
Regulated Pollutants other than Criteria and HAP	Potential Emissions	
	PPH	TPY

List the method(s) used to calculate the potential emissions (include dates of any stack tests conducted, versions of software used, source and dates of emission factors, etc.).

Applicable Requirements

List all applicable requirements for this emission unit. For each applicable requirement, include the underlying rule/regulation citation and/or construction permit with the condition number. (Note: Title V permit condition numbers alone are not the underlying applicable requirements). If an emission limit is calculated based on the type of source and design capacity or if a standard is based on a design parameter, this information should also be included.

From current Title V permit:

____ Permit Shield

For all applicable requirements listed above, provide monitoring/testing/recordkeeping/reporting which shall be used to demonstrate compliance. If the method is based on a permit or rule, include the condition number or citation. (Note: Each requirement listed above must have an associated method of demonstrating compliance. If there is not already a required method in place, then a method must be proposed.)

From current Title V permit:

Are you in compliance with all applicable requirements for this emission unit? Yes No

If no, complete the **Schedule of Compliance Form** as ATTACHMENT F.

ATTACHMENT E - Emission Unit Form

Emission Unit Description: *Storage Tank*

Emission unit ID number: 9773	Emission unit name: Tank 9773	List any control devices associated with this emission unit: N/A
---	---	--

Provide a description of the emission unit (type, method of operation, design parameters, etc.):
Storage tank.

Manufacturer:	Model number:	Serial number:
----------------------	----------------------	-----------------------

Construction date: See Attachment D Equipment Table	Installation date: See Attachment D Equipment Table	Modification date(s): See Attachment D Equipment Table
---	---	--

Design Capacity (examples: furnaces - tons/hr, tanks - gallons): See Attachment D Equipment Table

Maximum Hourly Throughput:	Maximum Annual Throughput:	Maximum Operating Schedule: 24 hrs/day, 365 days/yr
-----------------------------------	-----------------------------------	---

Fuel Usage Data (fill out all applicable fields)

Does this emission unit combust fuel? <input type="checkbox"/> Yes <input checked="" type="checkbox"/> No	If yes, is it? <input type="checkbox"/> Indirect Fired <input type="checkbox"/> Direct Fired
--	--

Maximum design heat input and/or maximum horsepower rating:	Type and Btu/hr rating of burners:
--	---

List the primary fuel type(s) and if applicable, the secondary fuel type(s). For each fuel type listed, provide the maximum hourly and annual fuel usage for each.

Describe each fuel expected to be used during the term of the permit.

Fuel Type	Max. Sulfur Content	Max. Ash Content	BTU Value

<i>Emissions Data</i>		
Criteria Pollutants	Potential Emissions	
	PPH	TPY
Carbon Monoxide (CO)		
Nitrogen Oxides (NO _x)		
Lead (Pb)		
Particulate Matter (PM _{2.5})		
Particulate Matter (PM ₁₀)		
Total Particulate Matter (TSP)		
Sulfur Dioxide (SO ₂)		
Volatile Organic Compounds (VOC)		
Hazardous Air Pollutants	Potential Emissions	
	PPH	TPY
Regulated Pollutants other than Criteria and HAP	Potential Emissions	
	PPH	TPY

List the method(s) used to calculate the potential emissions (include dates of any stack tests conducted, versions of software used, source and dates of emission factors, etc.).

Applicable Requirements

List all applicable requirements for this emission unit. For each applicable requirement, include the underlying rule/regulation citation and/or construction permit with the condition number. (Note: Title V permit condition numbers alone are not the underlying applicable requirements). If an emission limit is calculated based on the type of source and design capacity or if a standard is based on a design parameter, this information should also be included.

From current Title V permit:

____ Permit Shield

For all applicable requirements listed above, provide monitoring/testing/recordkeeping/reporting which shall be used to demonstrate compliance. If the method is based on a permit or rule, include the condition number or citation. (Note: Each requirement listed above must have an associated method of demonstrating compliance. If there is not already a required method in place, then a method must be proposed.)

From current Title V permit:

Are you in compliance with all applicable requirements for this emission unit? Yes No

If no, complete the **Schedule of Compliance Form** as ATTACHMENT F.

ATTACHMENT E - Emission Unit Form

Emission Unit Description: *Storage Tank*

Emission unit ID number: 9774	Emission unit name: Tank 9774	List any control devices associated with this emission unit: N/A
---	---	--

Provide a description of the emission unit (type, method of operation, design parameters, etc.):
Storage tank.

Manufacturer:	Model number:	Serial number:
----------------------	----------------------	-----------------------

Construction date: See Attachment D Equipment Table	Installation date: See Attachment D Equipment Table	Modification date(s): See Attachment D Equipment Table
---	---	--

Design Capacity (examples: furnaces - tons/hr, tanks - gallons): See Attachment D Equipment Table

Maximum Hourly Throughput:	Maximum Annual Throughput:	Maximum Operating Schedule: 24 hrs/day, 365 days/yr
-----------------------------------	-----------------------------------	---

Fuel Usage Data (fill out all applicable fields)

Does this emission unit combust fuel? <input type="checkbox"/> Yes <input checked="" type="checkbox"/> No	If yes, is it? <input type="checkbox"/> Indirect Fired <input type="checkbox"/> Direct Fired
--	--

Maximum design heat input and/or maximum horsepower rating:	Type and Btu/hr rating of burners:
--	---

List the primary fuel type(s) and if applicable, the secondary fuel type(s). For each fuel type listed, provide the maximum hourly and annual fuel usage for each.

Describe each fuel expected to be used during the term of the permit.

Fuel Type	Max. Sulfur Content	Max. Ash Content	BTU Value

<i>Emissions Data</i>		
Criteria Pollutants	Potential Emissions	
	PPH	TPY
Carbon Monoxide (CO)		
Nitrogen Oxides (NO _x)		
Lead (Pb)		
Particulate Matter (PM _{2.5})		
Particulate Matter (PM ₁₀)		
Total Particulate Matter (TSP)		
Sulfur Dioxide (SO ₂)		
Volatile Organic Compounds (VOC)		
Hazardous Air Pollutants	Potential Emissions	
	PPH	TPY
Regulated Pollutants other than Criteria and HAP	Potential Emissions	
	PPH	TPY

List the method(s) used to calculate the potential emissions (include dates of any stack tests conducted, versions of software used, source and dates of emission factors, etc.).

Applicable Requirements

List all applicable requirements for this emission unit. For each applicable requirement, include the underlying rule/regulation citation and/or construction permit with the condition number. (Note: Title V permit condition numbers alone are not the underlying applicable requirements). If an emission limit is calculated based on the type of source and design capacity or if a standard is based on a design parameter, this information should also be included.

From current Title V permit:

____ Permit Shield

For all applicable requirements listed above, provide monitoring/testing/recordkeeping/reporting which shall be used to demonstrate compliance. If the method is based on a permit or rule, include the condition number or citation. (Note: Each requirement listed above must have an associated method of demonstrating compliance. If there is not already a required method in place, then a method must be proposed.)

From current Title V permit:

Are you in compliance with all applicable requirements for this emission unit? Yes No

If no, complete the **Schedule of Compliance Form** as ATTACHMENT F.

ATTACHMENT E - Emission Unit Form

Emission Unit Description: *Storage Tank*

Emission unit ID number: 9775	Emission unit name: Tank 9775	List any control devices associated with this emission unit: N/A
---	---	--

Provide a description of the emission unit (type, method of operation, design parameters, etc.):
Storage tank.

Manufacturer:	Model number:	Serial number:
----------------------	----------------------	-----------------------

Construction date: See Attachment D Equipment Table	Installation date: See Attachment D Equipment Table	Modification date(s): See Attachment D Equipment Table
---	---	--

Design Capacity (examples: furnaces - tons/hr, tanks - gallons): See Attachment D Equipment Table

Maximum Hourly Throughput:	Maximum Annual Throughput:	Maximum Operating Schedule: 24 hrs/day, 365 days/yr
-----------------------------------	-----------------------------------	---

Fuel Usage Data (fill out all applicable fields)

Does this emission unit combust fuel? <input type="checkbox"/> Yes <input checked="" type="checkbox"/> No	If yes, is it? <input type="checkbox"/> Indirect Fired <input type="checkbox"/> Direct Fired
--	--

Maximum design heat input and/or maximum horsepower rating:	Type and Btu/hr rating of burners:
--	---

List the primary fuel type(s) and if applicable, the secondary fuel type(s). For each fuel type listed, provide the maximum hourly and annual fuel usage for each.

Describe each fuel expected to be used during the term of the permit.

Fuel Type	Max. Sulfur Content	Max. Ash Content	BTU Value

<i>Emissions Data</i>		
Criteria Pollutants	Potential Emissions	
	PPH	TPY
Carbon Monoxide (CO)		
Nitrogen Oxides (NO _x)		
Lead (Pb)		
Particulate Matter (PM _{2.5})		
Particulate Matter (PM ₁₀)		
Total Particulate Matter (TSP)		
Sulfur Dioxide (SO ₂)		
Volatile Organic Compounds (VOC)		
Hazardous Air Pollutants	Potential Emissions	
	PPH	TPY
Regulated Pollutants other than Criteria and HAP	Potential Emissions	
	PPH	TPY

List the method(s) used to calculate the potential emissions (include dates of any stack tests conducted, versions of software used, source and dates of emission factors, etc.).

Applicable Requirements

List all applicable requirements for this emission unit. For each applicable requirement, include the underlying rule/regulation citation and/or construction permit with the condition number. (Note: Title V permit condition numbers alone are not the underlying applicable requirements). If an emission limit is calculated based on the type of source and design capacity or if a standard is based on a design parameter, this information should also be included.

From current Title V permit:

____ Permit Shield

For all applicable requirements listed above, provide monitoring/testing/recordkeeping/reporting which shall be used to demonstrate compliance. If the method is based on a permit or rule, include the condition number or citation. (Note: Each requirement listed above must have an associated method of demonstrating compliance. If there is not already a required method in place, then a method must be proposed.)

From current Title V permit:

Are you in compliance with all applicable requirements for this emission unit? Yes No

If no, complete the **Schedule of Compliance Form** as ATTACHMENT F.

ATTACHMENT E - Emission Unit Form

Emission Unit Description: *Storage Tank*

Emission unit ID number: 9776	Emission unit name: Tank 9776	List any control devices associated with this emission unit: N/A
---	---	--

Provide a description of the emission unit (type, method of operation, design parameters, etc.):
Storage tank.

Manufacturer:	Model number:	Serial number:
----------------------	----------------------	-----------------------

Construction date: See Attachment D Equipment Table	Installation date: See Attachment D Equipment Table	Modification date(s): See Attachment D Equipment Table
---	---	--

Design Capacity (examples: furnaces - tons/hr, tanks - gallons): See Attachment D Equipment Table

Maximum Hourly Throughput:	Maximum Annual Throughput:	Maximum Operating Schedule: 24 hrs/day, 365 days/yr
-----------------------------------	-----------------------------------	---

Fuel Usage Data (fill out all applicable fields)

Does this emission unit combust fuel? <input type="checkbox"/> Yes <input checked="" type="checkbox"/> No	If yes, is it? <input type="checkbox"/> Indirect Fired <input type="checkbox"/> Direct Fired
--	--

Maximum design heat input and/or maximum horsepower rating:	Type and Btu/hr rating of burners:
--	---

List the primary fuel type(s) and if applicable, the secondary fuel type(s). For each fuel type listed, provide the maximum hourly and annual fuel usage for each.

Describe each fuel expected to be used during the term of the permit.

Fuel Type	Max. Sulfur Content	Max. Ash Content	BTU Value

<i>Emissions Data</i>		
Criteria Pollutants	Potential Emissions	
	PPH	TPY
Carbon Monoxide (CO)		
Nitrogen Oxides (NO _x)		
Lead (Pb)		
Particulate Matter (PM _{2.5})		
Particulate Matter (PM ₁₀)		
Total Particulate Matter (TSP)		
Sulfur Dioxide (SO ₂)		
Volatile Organic Compounds (VOC)		
Hazardous Air Pollutants	Potential Emissions	
	PPH	TPY
Regulated Pollutants other than Criteria and HAP	Potential Emissions	
	PPH	TPY

List the method(s) used to calculate the potential emissions (include dates of any stack tests conducted, versions of software used, source and dates of emission factors, etc.).

Applicable Requirements

List all applicable requirements for this emission unit. For each applicable requirement, include the underlying rule/regulation citation and/or construction permit with the condition number. (Note: Title V permit condition numbers alone are not the underlying applicable requirements). If an emission limit is calculated based on the type of source and design capacity or if a standard is based on a design parameter, this information should also be included.

From current Title V permit:

____ Permit Shield

For all applicable requirements listed above, provide monitoring/testing/recordkeeping/reporting which shall be used to demonstrate compliance. If the method is based on a permit or rule, include the condition number or citation. (Note: Each requirement listed above must have an associated method of demonstrating compliance. If there is not already a required method in place, then a method must be proposed.)

From current Title V permit:

Are you in compliance with all applicable requirements for this emission unit? Yes No

If no, complete the **Schedule of Compliance Form** as ATTACHMENT F.

ATTACHMENT E - Emission Unit Form

Emission Unit Description _ Chlorobenzene/Chlorohydrin (Area 42) Remediation System

Emission unit ID number: CLBVE/A42VE	Emission unit name: Groundwater/soil vapor extraction process with associated regenerative thermal oxidizer and packed bed scrubber.	List any control devices associated with this emission unit: A42INC and A42PBS
--	--	--

Provide a description of the emission unit (type, method of operation, design parameters, etc.):
 Vapor Extractive System is used to extract volatile organic compounds (VOCs) from soil and groundwater. The system includes a vacuum source, knock-out pot, incinerator, packed bed scrubber and associated piping to strip VOCs from soil and groundwater.

Manufacturer: Custom Design	Model number: Not Applicable	Serial number: Not Applicable
Construction date: See Attachment D Equipment Table	Installation date: See Attachment D Equipment Table	Modification date(s): See Attachment D Equipment Table

Design Capacity (examples: furnaces - tons/hr, tanks - gallons): See Attachment D Equipment Table

Maximum Hourly Throughput:	Maximum Annual Throughput:	Maximum Operating Schedule: 24 hrs/day, 365 days/yr
-----------------------------------	-----------------------------------	---

Fuel Usage Data (fill out all applicable fields)

Does this emission unit combust fuel? <input type="checkbox"/> Yes <input checked="" type="checkbox"/> No	If yes, is it? <input type="checkbox"/> Indirect Fired <input type="checkbox"/> Direct Fired
--	--

Maximum design heat input and/or maximum horsepower rating:	Type and Btu/hr rating of burners:
--	---

List the primary fuel type(s) and if applicable, the secondary fuel type(s). For each fuel type listed, provide the maximum hourly and annual fuel usage for each.

Describe each fuel expected to be used during the term of the permit.			
Fuel Type	Max. Sulfur Content	Max. Ash Content	BTU Value
Emissions Data: See Emission Unit Form for			
Criteria Pollutants	Potential Emissions (See Emission Unit Form for Catalytic Incinerator. Potential emissions limited by Regulation 13 Permit R13-3025A)		
	PPH	TPY	
Carbon Monoxide (CO)			
Nitrogen Oxides (NO _x)			
Lead (Pb)			
Particulate Matter (PM _{2.5})			
Particulate Matter (PM ₁₀)			
Total Particulate Matter (TSP)			
Sulfur Dioxide (SO ₂)			
Volatile Organic Compounds (VOC)			
Hazardous Air Pollutants	Potential Emissions		
	PPH	TPY	
Hexane			
Benzene			
Total HAPs			
Regulated Pollutants other than Criteria and HAP	Potential Emissions		
	PPH	TPY	
List the method(s) used to calculate the potential emissions (include dates of any stack tests conducted, versions of software used, source and dates of emission factors, etc.).			
Engineering calculations.			

Applicable Requirements

List all applicable requirements for this emission unit. For each applicable requirement, include the underlying rule/regulation citation and/or construction permit with the condition number. (Note: Title V permit condition numbers alone are not the underlying applicable requirements). If an emission limit is calculated based on the type of source and design capacity or if a standard is based on a design parameter, this information should also be included.

Applicable requirements, monitoring, recordkeeping, reporting and testing copied from current permit R30-03900003-2018 as amended. See Attachment I.

Permit Shield

For all applicable requirements listed above, provide monitoring/testing/recordkeeping/reporting which shall be used to demonstrate compliance. If the method is based on a permit or rule, include the condition number or citation. (Note: Each requirement listed above must have an associated method of demonstrating compliance. If there is not already a required method in place, then a method must be proposed.)

Applicable requirements, monitoring, recordkeeping, reporting and testing copied from current permit R30-03900003-2018 as amended. See Attachment I.

Are you in compliance with all applicable requirements for this emission unit? Yes No

If no, complete the **Schedule of Compliance Form** as **ATTACHMENT F**.

ATTACHMENT E - Emission Unit Form

Emission Unit Description _ Chlorobenzene/Chlorohydrin (Area 42) Remediation System

Emission unit ID number: CLB2VE	Emission unit name: Chlorobenzene Area 2 Vapor Extraction System	List any control devices associated with this emission unit: A42INC/A42PBS or CLB2VGAC
---	--	--

Provide a description of the emission unit (type, method of operation, design parameters, etc.):
Soil remediation system using in-situ thermal treatment. Vapor stream emissions will be controlled through regenerative thermal oxidizer (RTO) followed by a packed bed scrubber or granulated activated carbon for VOHAP emissions during instances where RTO is offline. Total maximum flow rate from the systems will be approximately 800 scfm.

Manufacturer: Custom Design	Model number: Not Applicable	Serial number: Not Applicable
---------------------------------------	--	---

Construction date: See Attachment D Equipment Table	Installation date: See Attachment D Equipment Table	Modification date(s): See Attachment D Equipment Table
---	---	--

Design Capacity (examples: furnaces - tons/hr, tanks - gallons): See Attachment D Equipment Table

Maximum Hourly Throughput:	Maximum Annual Throughput:	Maximum Operating Schedule: 24 hrs/day, 365 days/year
-----------------------------------	-----------------------------------	---

Fuel Usage Data (fill out all applicable fields)

Does this emission unit combust fuel? <input type="checkbox"/> Yes <input checked="" type="checkbox"/> No	If yes, is it? <input type="checkbox"/> Indirect Fired <input type="checkbox"/> Direct Fired
--	--

Maximum design heat input and/or maximum horsepower rating:	Type and Btu/hr rating of burners:
--	---

List the primary fuel type(s) and if applicable, the secondary fuel type(s). For each fuel type listed, provide the maximum hourly and annual fuel usage for each.

Describe each fuel expected to be used during the term of the permit.			
Fuel Type	Max. Sulfur Content	Max. Ash Content	BTU Value
Emissions Data: (See current Title V permit for emissions routed through A42INC/A42PBS.) Emissions from use of alternative control device, CLB2VGAC, are listed below and come from R13-2840E, issued May 11, 2022.)			
Criteria Pollutants	Potential Emissions		
	PPH	TPY	
Carbon Monoxide (CO)			
Nitrogen Oxides (NO _x)			
Lead (Pb)			
Particulate Matter (PM _{2.5})			
Particulate Matter (PM ₁₀)			
Total Particulate Matter (TSP)			
Sulfur Dioxide (SO ₂)			
Volatile Organic Compounds (VOC)			
Hazardous Air Pollutants	Potential Emissions		
	PPH	TPY	
Ethylbenzene	0.01	0.01	
Naphthalene	0.08	0.14	
Xylene	0.01	0.01	
Regulated Pollutants other than Criteria and HAP	Potential Emissions		
	PPH	TPY	
List the method(s) used to calculate the potential emissions (include dates of any stack tests conducted, versions of software used, source and dates of emission factors, etc.).			
Engineering calculations.			

Applicable Requirements

List all applicable requirements for this emission unit. For each applicable requirement, include the underlying rule/regulation citation and/or construction permit with the condition number. (Note: Title V permit condition numbers alone are not the underlying applicable requirements). If an emission limit is calculated based on the type of source and design capacity or if a standard is based on a design parameter, this information should also be included.

Applicable requirements, monitoring, recordkeeping, reporting and testing copied from current permit R13-2840E. See Attachment J. This equipment has not been installed yet. It was added to R13-2840E, which was issued on May 11, 2022.

Permit Shield

For all applicable requirements listed above, provide monitoring/testing/recordkeeping/reporting which shall be used to demonstrate compliance. If the method is based on a permit or rule, include the condition number or citation. (Note: Each requirement listed above must have an associated method of demonstrating compliance. If there is not already a required method in place, then a method must be proposed.)

Applicable requirements, monitoring, recordkeeping, reporting and testing copied from current permit R13-2840E. See Attachment J. This equipment has not been installed yet. It was added to R13-2840E, which was issued on May 11, 2022.

Are you in compliance with all applicable requirements for this emission unit? Yes No

If no, complete the **Schedule of Compliance Form** as **ATTACHMENT F**.

ATTACHMENT E - Emission Unit Form

Emission Unit Description _ Middle Island Groundwater Containment System

Emission unit ID number: MIGCS	Emission unit name: Middle Island (MI) Groundwater Containment System with associated electric catalytic oxidizer and granular activated carbon	List any control devices associated with this emission unit: MIGCS CO or MIGCS GAC
--	---	--

Provide a description of the emission unit (type, method of operation, design parameters, etc.):
 MI Groundwater Containment System extracts contaminated groundwater from the subsurface and treats it via an oil/water separator, clarifier, siphon tank, and cascade aerator. Emissions from the groundwater treatment train are routed through an electric catalytic oxidizer (MIGCS CO) for further reduction of VOHAP concentrations. The vapor system is also permitted to use granular activated carbon (MIGCS GAC) as alternative treatment device.

Manufacturer: Custom Design	Model number: Not Applicable	Serial number: Not Applicable
---------------------------------------	--	---

Construction date: See Attachment D Equipment Table	Installation date: See Attachment D Equipment Table	Modification date(s): See Attachment D Equipment Table
---	---	--

Design Capacity (examples: furnaces - tons/hr, tanks - gallons): See Attachment D Equipment Table

Maximum Hourly Throughput:	Maximum Annual Throughput:	Maximum Operating Schedule: 24 hrs/day, 365 days/yr
-----------------------------------	-----------------------------------	---

Fuel Usage Data (fill out all applicable fields)

Does this emission unit combust fuel? <input type="checkbox"/> Yes <input checked="" type="checkbox"/> No	If yes, is it? <input type="checkbox"/> Indirect Fired <input type="checkbox"/> Direct Fired
--	--

Maximum design heat input and/or maximum horsepower rating:	Type and Btu/hr rating of burners:
--	---

List the primary fuel type(s) and if applicable, the secondary fuel type(s). For each fuel type listed, provide the maximum hourly and annual fuel usage for each.

Describe each fuel expected to be used during the term of the permit.			
Fuel Type	Max. Sulfur Content	Max. Ash Content	BTU Value
Emissions Data: (See current Title V permit.) (Potential emissions limited by Rule 13 Permit R13-3308B.)			
Criteria Pollutants	Potential Emissions		
	PPH	TPY	
Carbon Monoxide (CO)			
Nitrogen Oxides (NO _x)			
Lead (Pb)			
Particulate Matter (PM _{2.5})			
Particulate Matter (PM ₁₀)			
Total Particulate Matter (TSP)			
Sulfur Dioxide (SO ₂)			
Volatile Organic Compounds (VOC)			
Hazardous Air Pollutants	Potential Emissions		
	PPH	TPY	
Total HAPs			
Regulated Pollutants other than Criteria and HAP	Potential Emissions		
	PPH	TPY	
List the method(s) used to calculate the potential emissions (include dates of any stack tests conducted, versions of software used, source and dates of emission factors, etc.).			
Engineering calculations.			

Applicable Requirements

List all applicable requirements for this emission unit. For each applicable requirement, include the underlying rule/regulation citation and/or construction permit with the condition number. (Note: Title V permit condition numbers alone are not the underlying applicable requirements). If an emission limit is calculated based on the type of source and design capacity or if a standard is based on a design parameter, this information should also be included.

Applicable requirements, monitoring, recordkeeping, reporting and testing copied from current permit R30-03900003-2018 as amended. See Attachment I.

____ Permit Shield

For all applicable requirements listed above, provide monitoring/testing/recordkeeping/reporting which shall be used to demonstrate compliance. If the method is based on a permit or rule, include the condition number or citation. (Note: Each requirement listed above must have an associated method of demonstrating compliance. If there is not already a required method in place, then a method must be proposed.)

Applicable requirements, monitoring, recordkeeping, reporting and testing copied from current permit R30-03900003-2018 as amended. See Attachment I.

Are you in compliance with all applicable requirements for this emission unit? Yes No

If no, complete the **Schedule of Compliance Form** as **ATTACHMENT F**.

ATTACHMENT E - Emission Unit Form

Emission Unit Description

Emission unit ID number: A42INC	Emission unit name: Regenerative Thermal Oxidizer	List any control devices associated with this emission unit: A42PBS
---	---	---

Provide a description of the emission unit (type, method of operation, design parameters, etc.):
The regenerative thermal oxidizer has a design capacity of 850 scfm and 109 lb/hr of VOCs.

Manufacturer: Anguil	Model number: AES-15103	Serial number:
--------------------------------	-----------------------------------	-----------------------

Construction date: See Attachment D Equipment Table	Installation date: See Attachment D Equipment Table	Modification date(s): See Attachment D Equipment Table
---	---	--

Design Capacity (examples: furnaces - tons/hr, tanks - gallons): See Attachment D Equipment Table
850 scfm, 109 lb/hr of VOCs

Maximum Hourly Throughput: 109 lb/hr of VOCs	Maximum Annual Throughput: 477 tpy of VOCs	Maximum Operating Schedule: 24 hrs/day, 365 days/yr
--	--	---

Fuel Usage Data (fill out all applicable fields)

Does this emission unit combust fuel? <input checked="" type="checkbox"/> Yes <input type="checkbox"/> No	If yes, is it? <input type="checkbox"/> Indirect Fired <input checked="" type="checkbox"/> Direct Fired
--	---

Maximum design heat input and/or maximum horsepower rating:	Type and Btu/hr rating of burners: -Maxon – nozzle mix burner. 175,000 Btu/hr
--	---

List the primary fuel type(s) and if applicable, the secondary fuel type(s). For each fuel type listed, provide the maximum hourly and annual fuel usage for each.

Natural Gas
Max hourly fuel usage- 1 MMBtu/hr
Estimated annual fuel usage- 300 MMBtu/yr

Describe each fuel expected to be used during the term of the permit.			
Fuel Type	Max. Sulfur Content	Max. Ash Content	BTU Value
Natural Gas	None	None	>1,050 Btu/scf
<i>Emissions Data</i>			
Criteria Pollutants	Potential Emissions		
	PPH	TPY	
Carbon Monoxide (CO)			
Nitrogen Oxides (NO _x)			
Lead (Pb)			
Particulate Matter (PM _{2.5})			
Particulate Matter (PM ₁₀)			
Total Particulate Matter (TSP)			
Sulfur Dioxide (SO ₂)			
Volatile Organic Compounds (VOC)			
Hazardous Air Pollutants	Potential Emissions		
	PPH	TPY	
Regulated Pollutants other than Criteria and HAP	Potential Emissions		
	PPH	TPY	
List the method(s) used to calculate the potential emissions (include dates of any stack tests conducted, versions of software used, source and dates of emission factors, etc.).			
Engineering calculations.			

Applicable Requirements

List all applicable requirements for this emission unit. For each applicable requirement, include the underlying rule/regulation citation and/or construction permit with the condition number. (Note: Title V permit condition numbers alone are not the underlying applicable requirements). If an emission limit is calculated based on the type of source and design capacity or if a standard is based on a design parameter, this information should also be included.

Applicable requirements, monitoring, recordkeeping, reporting and testing copied from current permit R30-03900003-2018 as amended. See Attachment I.

Permit Shield

For all applicable requirements listed above, provide monitoring/testing/recordkeeping/reporting which shall be used to demonstrate compliance. If the method is based on a permit or rule, include the condition number or citation. (Note: Each requirement listed above must have an associated method of demonstrating compliance. If there is not already a required method in place, then a method must be proposed.)

Applicable requirements, monitoring, recordkeeping, reporting and testing copied from current permit R30-03900003-2018 as amended. See Attachment I.

Are you in compliance with all applicable requirements for this emission unit? Yes No

If no, complete the **Schedule of Compliance Form** as ATTACHMENT F.

ATTACHMENT E - Emission Unit Form

Emission Unit Description _ Middle Island Source 2

Emission unit ID number: MI2CO	Emission unit name: Catalytic Oxidizer	List any control devices associated with this emission unit: MI2CO
--	--	--

Provide a description of the emission unit (type, method of operation, design parameters, etc.):
Vapor Extractive System is used to extract volatile organic compounds (VOCs) from soil and groundwater. The system includes a vacuum source and associated piping to strip VOCs from soil and groundwater.

Manufacturer: Anguil	Model number: Model OA10,-Unit 17336	Serial number: 17336
--------------------------------	--	--------------------------------

Construction date: See Attachment D Equipment Table	Installation date: See Attachment D Equipment Table	Modification date(s): See Attachment D Equipment Table
---	---	--

Design Capacity (examples: furnaces - tons/hr, tanks - gallons): See Attachment D Equipment Table

Maximum Hourly Throughput:	Maximum Annual Throughput:	Maximum Operating Schedule: 24 hrs/day, 365 days/yr
-----------------------------------	-----------------------------------	---

Fuel Usage Data (fill out all applicable fields)

Does this emission unit combust fuel? <input type="checkbox"/> Yes <input checked="" type="checkbox"/> No	If yes, is it? <input type="checkbox"/> Indirect Fired <input type="checkbox"/> Direct Fired
--	--

Maximum design heat input and/or maximum horsepower rating:	Type and Btu/hr rating of burners:
--	---

List the primary fuel type(s) and if applicable, the secondary fuel type(s). For each fuel type listed, provide the maximum hourly and annual fuel usage for each.
None: electricity used for heating of unit.

Describe each fuel expected to be used during the term of the permit.

Fuel Type	Max. Sulfur Content	Max. Ash Content	BTU Value

Emissions Data			
Criteria Pollutants	Potential Emissions – (Potential emissions limited by Regulation 13 Permit R13-3025A)		
	PPH	TPY	
Carbon Monoxide (CO)			
Nitrogen Oxides (NO _x)			
Lead (Pb)			
Particulate Matter (PM _{2.5})			
Particulate Matter (PM ₁₀)			
Total Particulate Matter (TSP)			
Sulfur Dioxide (SO ₂)			
Volatile Organic Compounds (VOC)	0.46	1.24	
Hazardous Air Pollutants	Potential Emissions		
	PPH	TPY	
Hexane	0.07	0.23	
Benzene	0.13	0.42	
Other HAPs* (e.g. includes but not limited to Acenaphthylene, Carbon disulfide, Ethyl benzene, Naphthalene, Styrene, toluene, and Xylenes.	0.10	0.22	
Total HAPs	0.3	0.87	
Regulated Pollutants other than Criteria and HAP	Potential Emissions		
	PPH	TPY	
List the method(s) used to calculate the potential emissions (include dates of any stack tests conducted, versions of software used, source and dates of emission factors, etc.). Engineering calculations.			

Applicable Requirements

List all applicable requirements for this emission unit. For each applicable requirement, include the underlying rule/regulation citation and/or construction permit with the condition number. (Note: Title V permit condition numbers alone are not the underlying applicable requirements). If an emission limit is calculated based on the type of source and design capacity or if a standard is based on a design parameter, this information should also be included.

Applicable requirements, monitoring, recordkeeping, reporting and testing copied from current permit R30-03900003-2018 as amended. See Attachment I.

Permit Shield

For all applicable requirements listed above, provide monitoring/testing/recordkeeping/reporting which shall be used to demonstrate compliance. If the method is based on a permit or rule, include the condition number or citation. (Note: Each requirement listed above must have an associated method of demonstrating compliance. If there is not already a required method in place, then a method must be proposed.)

Applicable requirements, monitoring, recordkeeping, reporting and testing copied from current permit R30-03900003-2018 as amended. See Attachment I.

Are you in compliance with all applicable requirements for this emission unit? Yes No

If no, complete the **Schedule of Compliance Form** as **ATTACHMENT F**.

ATTACHMENT E - Emission Unit Form

Emission Unit Description _ Middle Island Source 2

Emission unit ID number: MI2VE	Emission unit name: Catalytic Oxidizer Vapor Extractive System	List any control devices associated with this emission unit: MI2CO
--	--	--

Provide a description of the emission unit (type, method of operation, design parameters, etc.):
Vapor Extractive System is used to extract volatile organic compounds (VOCs) from soil and groundwater. The system includes a vacuum source, an incinerator and associated piping to strip VOCs from soil and groundwater.

Manufacturer: Custom Design	Model number: Not Applicable	Serial number: Not Applicable
---------------------------------------	--	---

Construction date: See Attachment D Equipment Table	Installation date: See Attachment D Equipment Table	Modification date(s): See Attachment D Equipment Table
---	---	--

Design Capacity (examples: furnaces - tons/hr, tanks - gallons): See Attachment D Equipment Table

Maximum Hourly Throughput:	Maximum Annual Throughput:	Maximum Operating Schedule: 24 hrs/day, 365 days/yr
-----------------------------------	-----------------------------------	---

Fuel Usage Data (fill out all applicable fields)

Does this emission unit combust fuel? <input type="checkbox"/> Yes <input checked="" type="checkbox"/> No	If yes, is it? <input type="checkbox"/> Indirect Fired <input type="checkbox"/> Direct Fired
--	--

Maximum design heat input and/or maximum horsepower rating:	Type and Btu/hr rating of burners:
--	---

List the primary fuel type(s) and if applicable, the secondary fuel type(s). For each fuel type listed, provide the maximum hourly and annual fuel usage for each.

Describe each fuel expected to be used during the term of the permit.

Fuel Type	Max. Sulfur Content	Max. Ash Content	BTU Value

Emissions Data			
Criteria Pollutants	Potential Emissions		
	PPH	TPY	
Carbon Monoxide (CO)			
Nitrogen Oxides (NO _x)			
Lead (Pb)			
Particulate Matter (PM _{2.5})			
Particulate Matter (PM ₁₀)			
Total Particulate Matter (TSP)			
Sulfur Dioxide (SO ₂)			
Volatile Organic Compounds (VOC)			
Hazardous Air Pollutants	Potential Emissions		
	PPH	TPY	
Hexane			
Benzene			
Total HAPs			
Regulated Pollutants other than Criteria and HAP	Potential Emissions		
	PPH	TPY	
<p>List the method(s) used to calculate the potential emissions (include dates of any stack tests conducted, versions of software used, source and dates of emission factors, etc.).</p> <p>Engineering calculations.</p>			

Applicable Requirements

List all applicable requirements for this emission unit. For each applicable requirement, include the underlying rule/regulation citation and/or construction permit with the condition number. (Note: Title V permit condition numbers alone are not the underlying applicable requirements). If an emission limit is calculated based on the type of source and design capacity or if a standard is based on a design parameter, this information should also be included.

Applicable requirements, monitoring, recordkeeping, reporting and testing copied from current permit R30-03900003-2018 as amended. See Attachment I.

Permit Shield

For all applicable requirements listed above, provide monitoring/testing/recordkeeping/reporting which shall be used to demonstrate compliance. If the method is based on a permit or rule, include the condition number or citation. (Note: Each requirement listed above must have an associated method of demonstrating compliance. If there is not already a required method in place, then a method must be proposed.)

Applicable requirements, monitoring, recordkeeping, reporting and testing copied from current permit R30-03900003-2018 as amended. See Attachment I.

Are you in compliance with all applicable requirements for this emission unit? Yes No

If no, complete the **Schedule of Compliance Form** as ATTACHMENT F.

ATTACHMENT E - Emission Unit Form

Emission Unit Description: Storage Tank

Emission unit ID number: 8343	Emission unit name: Tank 8343	List any control devices associated with this emission unit:
---	---	---

Provide a description of the emission unit (type, method of operation, design parameters, etc.):
Storage of volatile organic liquid

Manufacturer:	Model number:	Serial number:
----------------------	----------------------	-----------------------

Construction date: See Attachment D Equipment Table	Installation date: See Attachment D Equipment Table	Modification date(s): See Attachment D Equipment Table
---	---	--

Design Capacity (examples: furnaces - tons/hr, tanks - gallons): See Attachment D Equipment Table

Maximum Hourly Throughput:	Maximum Annual Throughput:	Maximum Operating Schedule: 24 hrs/day, 365 days/yr
-----------------------------------	-----------------------------------	---

Fuel Usage Data (fill out all applicable fields)

Does this emission unit combust fuel? ___ Yes <u> X </u> No	If yes, is it? ___ Indirect Fired ___ Direct Fired
--	--

Maximum design heat input and/or maximum horsepower rating:	Type and Btu/hr rating of burners:
--	---

List the primary fuel type(s) and if applicable, the secondary fuel type(s). For each fuel type listed, provide the maximum hourly and annual fuel usage for each.

Describe each fuel expected to be used during the term of the permit.

Fuel Type	Max. Sulfur Content	Max. Ash Content	BTU Value

Union Carbide Corporation South Charleston Facility – TRITON

<i>Emissions Data</i>		
Criteria Pollutants	Potential Emissions	
	PPH	TPY
Carbon Monoxide (CO)		
Nitrogen Oxides (NO _x)		
Lead (Pb)		
Particulate Matter (PM _{2.5})		
Particulate Matter (PM ₁₀)		
Total Particulate Matter (TSP)		
Sulfur Dioxide (SO ₂)		
Volatile Organic Compounds (VOC)		
Hazardous Air Pollutants	Potential Emissions	
	PPH	TPY
Regulated Pollutants other than Criteria and HAP	Potential Emissions	
	PPH	TPY

List the method(s) used to calculate the potential emissions (include dates of any stack tests conducted, versions of software used, source and dates of emission factors, etc.).

Applicable Requirements

List all applicable requirements for this emission unit. For each applicable requirement, include the underlying rule/regulation citation and/or construction permit with the condition number. (Note: Title V permit condition numbers alone are not the underlying applicable requirements). If an emission limit is calculated based on the type of source and design capacity or if a standard is based on a design parameter, this information should also be included.

See Attachment I for applicable requirements, monitoring, recordkeeping, reporting and testing from existing Title V permit.

X Permit Shield

For all applicable requirements listed above, provide monitoring/testing/recordkeeping/reporting which shall be used to demonstrate compliance. If the method is based on a permit or rule, include the condition number or citation. (Note: Each requirement listed above must have an associated method of demonstrating compliance. If there is not already a required method in place, then a method must be proposed.)

See Attachment I for applicable requirements, monitoring, recordkeeping, reporting and testing from existing Title V permit.

Are you in compliance with all applicable requirements for this emission unit? X Yes No

If no, complete the **Schedule of Compliance Form** as **ATTACHMENT F**.

ATTACHMENT E - Emission Unit Form

Emission Unit Description: Storage Tank

Emission unit ID number: 8334	Emission unit name: Tank 8334	List any control devices associated with this emission unit:
---	---	---

Provide a description of the emission unit (type, method of operation, design parameters, etc.):
Storage of volatile organic liquid

Manufacturer:	Model number:	Serial number:
----------------------	----------------------	-----------------------

Construction date: See Attachment D Equipment Table	Installation date: See Attachment D Equipment Table	Modification date(s): See Attachment D Equipment Table
---	---	--

Design Capacity (examples: furnaces - tons/hr, tanks - gallons): See Attachment D Equipment Table

Maximum Hourly Throughput:	Maximum Annual Throughput:	Maximum Operating Schedule: 24 hrs/day, 365 days/yr
-----------------------------------	-----------------------------------	---

Fuel Usage Data (fill out all applicable fields)

Does this emission unit combust fuel? ___Yes <u>X</u> No	If yes, is it? ___ Indirect Fired ___ Direct Fired
---	--

Maximum design heat input and/or maximum horsepower rating:	Type and Btu/hr rating of burners:
--	---

List the primary fuel type(s) and if applicable, the secondary fuel type(s). For each fuel type listed, provide the maximum hourly and annual fuel usage for each.

Describe each fuel expected to be used during the term of the permit.

Fuel Type	Max. Sulfur Content	Max. Ash Content	BTU Value

Union Carbide Corporation South Charleston Facility – TRITON

<i>Emissions Data</i>		
Criteria Pollutants	Potential Emissions	
	PPH	TPY
Carbon Monoxide (CO)		
Nitrogen Oxides (NO _x)		
Lead (Pb)		
Particulate Matter (PM _{2.5})		
Particulate Matter (PM ₁₀)		
Total Particulate Matter (TSP)		
Sulfur Dioxide (SO ₂)		
Volatile Organic Compounds (VOC)		
Hazardous Air Pollutants	Potential Emissions	
	PPH	TPY
Regulated Pollutants other than Criteria and HAP	Potential Emissions	
	PPH	TPY

List the method(s) used to calculate the potential emissions (include dates of any stack tests conducted, versions of software used, source and dates of emission factors, etc.).

Applicable Requirements

List all applicable requirements for this emission unit. For each applicable requirement, include the underlying rule/regulation citation and/or construction permit with the condition number. (Note: Title V permit condition numbers alone are not the underlying applicable requirements). If an emission limit is calculated based on the type of source and design capacity or if a standard is based on a design parameter, this information should also be included.

See Attachment I for applicable requirements, monitoring, recordkeeping, reporting and testing from existing Title V permit.

Permit Shield

For all applicable requirements listed above, provide monitoring/testing/recordkeeping/reporting which shall be used to demonstrate compliance. If the method is based on a permit or rule, include the condition number or citation. (Note: Each requirement listed above must have an associated method of demonstrating compliance. If there is not already a required method in place, then a method must be proposed.)

See Attachment I for applicable requirements, monitoring, recordkeeping, reporting and testing from existing Title V permit.

Are you in compliance with all applicable requirements for this emission unit? Yes No

If no, complete the **Schedule of Compliance Form** as ATTACHMENT F.

ATTACHMENT E - Emission Unit Form

Emission Unit Description: Storage Tank

Emission unit ID number: 8340	Emission unit name: Tank 8340	List any control devices associated with this emission unit: C8110 and C8130
---	---	--

Provide a description of the emission unit (type, method of operation, design parameters, etc.):
Storage of volatile organic liquid

Manufacturer:	Model number:	Serial number:
----------------------	----------------------	-----------------------

Construction date: See Attachment D Equipment Table	Installation date: See Attachment D Equipment Table	Modification date(s): See Attachment D Equipment Table
---	---	--

Design Capacity (examples: furnaces - tons/hr, tanks - gallons): See Attachment D Equipment Table

Maximum Hourly Throughput:	Maximum Annual Throughput:	Maximum Operating Schedule: 24 hrs/day, 365 days/yr
-----------------------------------	-----------------------------------	---

Fuel Usage Data (fill out all applicable fields)

Does this emission unit combust fuel? ___Yes <u>X</u> No	If yes, is it? ___ Indirect Fired ___ Direct Fired
---	--

Maximum design heat input and/or maximum horsepower rating:	Type and Btu/hr rating of burners:
--	---

List the primary fuel type(s) and if applicable, the secondary fuel type(s). For each fuel type listed, provide the maximum hourly and annual fuel usage for each.

Describe each fuel expected to be used during the term of the permit.

Fuel Type	Max. Sulfur Content	Max. Ash Content	BTU Value

Union Carbide Corporation South Charleston Facility – TRITON

<i>Emissions Data</i>		
Criteria Pollutants	Potential Emissions	
	PPH	TPY
Carbon Monoxide (CO)		
Nitrogen Oxides (NO _x)		
Lead (Pb)		
Particulate Matter (PM _{2.5})		
Particulate Matter (PM ₁₀)		
Total Particulate Matter (TSP)		
Sulfur Dioxide (SO ₂)		
Volatile Organic Compounds (VOC)		
Hazardous Air Pollutants	Potential Emissions	
	PPH	TPY
Regulated Pollutants other than Criteria and HAP	Potential Emissions	
	PPH	TPY

List the method(s) used to calculate the potential emissions (include dates of any stack tests conducted, versions of software used, source and dates of emission factors, etc.).

Applicable Requirements

List all applicable requirements for this emission unit. For each applicable requirement, include the underlying rule/regulation citation and/or construction permit with the condition number. (Note: Title V permit condition numbers alone are not the underlying applicable requirements). If an emission limit is calculated based on the type of source and design capacity or if a standard is based on a design parameter, this information should also be included.

See Attachment I for applicable requirements, monitoring, recordkeeping, reporting and testing from existing Title V permit.

X Permit Shield

For all applicable requirements listed above, provide monitoring/testing/recordkeeping/reporting which shall be used to demonstrate compliance. If the method is based on a permit or rule, include the condition number or citation. (Note: Each requirement listed above must have an associated method of demonstrating compliance. If there is not already a required method in place, then a method must be proposed.)

See Attachment I for applicable requirements, monitoring, recordkeeping, reporting and testing from existing Title V permit.

Are you in compliance with all applicable requirements for this emission unit? X Yes No

If no, complete the **Schedule of Compliance Form** as **ATTACHMENT F**.

ATTACHMENT E - Emission Unit Form

Emission Unit Description: Storage Tank

Emission unit ID number: 8331	Emission unit name: Tank 8331	List any control devices associated with this emission unit:
---	---	---

Provide a description of the emission unit (type, method of operation, design parameters, etc.):
Storage of volatile organic liquid

Manufacturer:	Model number:	Serial number:
----------------------	----------------------	-----------------------

Construction date: See Attachment D Equipment Table	Installation date: See Attachment D Equipment Table	Modification date(s): See Attachment D Equipment Table
---	---	--

Design Capacity (examples: furnaces - tons/hr, tanks - gallons): See Attachment D Equipment Table

Maximum Hourly Throughput:	Maximum Annual Throughput:	Maximum Operating Schedule: 24 hrs/day, 365 days/yr
-----------------------------------	-----------------------------------	---

Fuel Usage Data (fill out all applicable fields)

Does this emission unit combust fuel? ___Yes <u>X</u> No	If yes, is it? ___ Indirect Fired ___ Direct Fired
---	--

Maximum design heat input and/or maximum horsepower rating:	Type and Btu/hr rating of burners:
--	---

List the primary fuel type(s) and if applicable, the secondary fuel type(s). For each fuel type listed, provide the maximum hourly and annual fuel usage for each.

Describe each fuel expected to be used during the term of the permit.

Fuel Type	Max. Sulfur Content	Max. Ash Content	BTU Value

Union Carbide Corporation South Charleston Facility – TRITON

<i>Emissions Data</i>		
Criteria Pollutants	Potential Emissions	
	PPH	TPY
Carbon Monoxide (CO)		
Nitrogen Oxides (NO _x)		
Lead (Pb)		
Particulate Matter (PM _{2.5})		
Particulate Matter (PM ₁₀)		
Total Particulate Matter (TSP)		
Sulfur Dioxide (SO ₂)		
Volatile Organic Compounds (VOC)		
Hazardous Air Pollutants	Potential Emissions	
	PPH	TPY
Regulated Pollutants other than Criteria and HAP	Potential Emissions	
	PPH	TPY

List the method(s) used to calculate the potential emissions (include dates of any stack tests conducted, versions of software used, source and dates of emission factors, etc.).

Applicable Requirements

List all applicable requirements for this emission unit. For each applicable requirement, include the underlying rule/regulation citation and/or construction permit with the condition number. (Note: Title V permit condition numbers alone are not the underlying applicable requirements). If an emission limit is calculated based on the type of source and design capacity or if a standard is based on a design parameter, this information should also be included.

See Attachment I for applicable requirements, monitoring, recordkeeping, reporting and testing from existing Title V permit.

X Permit Shield

For all applicable requirements listed above, provide monitoring/testing/recordkeeping/reporting which shall be used to demonstrate compliance. If the method is based on a permit or rule, include the condition number or citation. (Note: Each requirement listed above must have an associated method of demonstrating compliance. If there is not already a required method in place, then a method must be proposed.)

See Attachment I for applicable requirements, monitoring, recordkeeping, reporting and testing from existing Title V permit.

Are you in compliance with all applicable requirements for this emission unit? X Yes No

If no, complete the **Schedule of Compliance Form** as ATTACHMENT F.

ATTACHMENT E - Emission Unit Form

Emission Unit Description: Storage Tank

Emission unit ID number: 8333	Emission unit name: Tank 8333	List any control devices associated with this emission unit:
---	---	---

Provide a description of the emission unit (type, method of operation, design parameters, etc.):
Storage of volatile organic liquid

Manufacturer:	Model number:	Serial number:
----------------------	----------------------	-----------------------

Construction date: See Attachment D Equipment Table	Installation date: See Attachment D Equipment Table	Modification date(s): See Attachment D Equipment Table
---	---	--

Design Capacity (examples: furnaces - tons/hr, tanks - gallons): See Attachment D Equipment Table

Maximum Hourly Throughput:	Maximum Annual Throughput:	Maximum Operating Schedule: 24 hrs/day, 365 days/yr
-----------------------------------	-----------------------------------	---

Fuel Usage Data (fill out all applicable fields)

Does this emission unit combust fuel? ___Yes <u>X</u> No	If yes, is it? ___ Indirect Fired ___ Direct Fired
---	--

Maximum design heat input and/or maximum horsepower rating:	Type and Btu/hr rating of burners:
--	---

List the primary fuel type(s) and if applicable, the secondary fuel type(s). For each fuel type listed, provide the maximum hourly and annual fuel usage for each.

Describe each fuel expected to be used during the term of the permit.

Fuel Type	Max. Sulfur Content	Max. Ash Content	BTU Value

Union Carbide Corporation South Charleston Facility – TRITON

<i>Emissions Data</i>		
Criteria Pollutants	Potential Emissions	
	PPH	TPY
Carbon Monoxide (CO)		
Nitrogen Oxides (NO _x)		
Lead (Pb)		
Particulate Matter (PM _{2.5})		
Particulate Matter (PM ₁₀)		
Total Particulate Matter (TSP)		
Sulfur Dioxide (SO ₂)		
Volatile Organic Compounds (VOC)		
Hazardous Air Pollutants	Potential Emissions	
	PPH	TPY
Regulated Pollutants other than Criteria and HAP	Potential Emissions	
	PPH	TPY

List the method(s) used to calculate the potential emissions (include dates of any stack tests conducted, versions of software used, source and dates of emission factors, etc.).

Applicable Requirements

List all applicable requirements for this emission unit. For each applicable requirement, include the underlying rule/regulation citation and/or construction permit with the condition number. (Note: Title V permit condition numbers alone are not the underlying applicable requirements). If an emission limit is calculated based on the type of source and design capacity or if a standard is based on a design parameter, this information should also be included.

See Attachment I for applicable requirements, monitoring, recordkeeping, reporting and testing from existing Title V permit.

X Permit Shield

For all applicable requirements listed above, provide monitoring/testing/recordkeeping/reporting which shall be used to demonstrate compliance. If the method is based on a permit or rule, include the condition number or citation. (Note: Each requirement listed above must have an associated method of demonstrating compliance. If there is not already a required method in place, then a method must be proposed.)

See Attachment I for applicable requirements, monitoring, recordkeeping, reporting and testing from existing Title V permit.

Are you in compliance with all applicable requirements for this emission unit? X Yes No

If no, complete the **Schedule of Compliance Form** as ATTACHMENT F.

ATTACHMENT E - Emission Unit Form

Emission Unit Description: Storage Tank

Emission unit ID number: 8332	Emission unit name: Tank 8332	List any control devices associated with this emission unit:
---	---	---

Provide a description of the emission unit (type, method of operation, design parameters, etc.):
Storage of volatile organic liquid

Manufacturer:	Model number:	Serial number:
----------------------	----------------------	-----------------------

Construction date: See Attachment D Equipment Table	Installation date: See Attachment D Equipment Table	Modification date(s): See Attachment D Equipment Table
---	---	--

Design Capacity (examples: furnaces - tons/hr, tanks - gallons): See Attachment D Equipment Table

Maximum Hourly Throughput:	Maximum Annual Throughput:	Maximum Operating Schedule: 24 hrs/day, 365 days/yr
-----------------------------------	-----------------------------------	---

Fuel Usage Data (fill out all applicable fields)

Does this emission unit combust fuel? ___ Yes <u> X </u> No	If yes, is it? ___ Indirect Fired ___ Direct Fired
--	--

Maximum design heat input and/or maximum horsepower rating:	Type and Btu/hr rating of burners:
--	---

List the primary fuel type(s) and if applicable, the secondary fuel type(s). For each fuel type listed, provide the maximum hourly and annual fuel usage for each.

Describe each fuel expected to be used during the term of the permit.

Fuel Type	Max. Sulfur Content	Max. Ash Content	BTU Value

Union Carbide Corporation South Charleston Facility – TRITON

<i>Emissions Data</i>		
Criteria Pollutants	Potential Emissions	
	PPH	TPY
Carbon Monoxide (CO)		
Nitrogen Oxides (NO _x)		
Lead (Pb)		
Particulate Matter (PM _{2.5})		
Particulate Matter (PM ₁₀)		
Total Particulate Matter (TSP)		
Sulfur Dioxide (SO ₂)		
Volatile Organic Compounds (VOC)		
Hazardous Air Pollutants	Potential Emissions	
	PPH	TPY
Regulated Pollutants other than Criteria and HAP	Potential Emissions	
	PPH	TPY

List the method(s) used to calculate the potential emissions (include dates of any stack tests conducted, versions of software used, source and dates of emission factors, etc.).

Applicable Requirements

List all applicable requirements for this emission unit. For each applicable requirement, include the underlying rule/regulation citation and/or construction permit with the condition number. (Note: Title V permit condition numbers alone are not the underlying applicable requirements). If an emission limit is calculated based on the type of source and design capacity or if a standard is based on a design parameter, this information should also be included.

See Attachment I for applicable requirements, monitoring, recordkeeping, reporting and testing from existing Title V permit.

X Permit Shield

For all applicable requirements listed above, provide monitoring/testing/recordkeeping/reporting which shall be used to demonstrate compliance. If the method is based on a permit or rule, include the condition number or citation. (Note: Each requirement listed above must have an associated method of demonstrating compliance. If there is not already a required method in place, then a method must be proposed.)

See Attachment I for applicable requirements, monitoring, recordkeeping, reporting and testing from existing Title V permit.

Are you in compliance with all applicable requirements for this emission unit? X Yes No

If no, complete the **Schedule of Compliance Form** as ATTACHMENT F.

ATTACHMENT E - Emission Unit Form

Emission Unit Description: Storage Tank

Emission unit ID number: 8330	Emission unit name: Tank 8330	List any control devices associated with this emission unit:
---	---	---

Provide a description of the emission unit (type, method of operation, design parameters, etc.):
Storage of volatile organic liquid

Manufacturer:	Model number:	Serial number:
----------------------	----------------------	-----------------------

Construction date: See Attachment D Equipment Table	Installation date: See Attachment D Equipment Table	Modification date(s): See Attachment D Equipment Table
---	---	--

Design Capacity (examples: furnaces - tons/hr, tanks - gallons): See Attachment D Equipment Table

Maximum Hourly Throughput:	Maximum Annual Throughput:	Maximum Operating Schedule: 24 hrs/day, 365 days/yr
-----------------------------------	-----------------------------------	---

Fuel Usage Data (fill out all applicable fields)

Does this emission unit combust fuel? ___Yes <u>X</u> No	If yes, is it? ___ Indirect Fired ___ Direct Fired
---	--

Maximum design heat input and/or maximum horsepower rating:	Type and Btu/hr rating of burners:
--	---

List the primary fuel type(s) and if applicable, the secondary fuel type(s). For each fuel type listed, provide the maximum hourly and annual fuel usage for each.

Describe each fuel expected to be used during the term of the permit.

Fuel Type	Max. Sulfur Content	Max. Ash Content	BTU Value

Union Carbide Corporation South Charleston Facility – TRITON

<i>Emissions Data</i>		
Criteria Pollutants	Potential Emissions	
	PPH	TPY
Carbon Monoxide (CO)		
Nitrogen Oxides (NO _x)		
Lead (Pb)		
Particulate Matter (PM _{2.5})		
Particulate Matter (PM ₁₀)		
Total Particulate Matter (TSP)		
Sulfur Dioxide (SO ₂)		
Volatile Organic Compounds (VOC)		
Hazardous Air Pollutants	Potential Emissions	
	PPH	TPY
Regulated Pollutants other than Criteria and HAP	Potential Emissions	
	PPH	TPY

List the method(s) used to calculate the potential emissions (include dates of any stack tests conducted, versions of software used, source and dates of emission factors, etc.).

Applicable Requirements

List all applicable requirements for this emission unit. For each applicable requirement, include the underlying rule/regulation citation and/or construction permit with the condition number. (Note: Title V permit condition numbers alone are not the underlying applicable requirements). If an emission limit is calculated based on the type of source and design capacity or if a standard is based on a design parameter, this information should also be included.

See Attachment I for applicable requirements, monitoring, recordkeeping, reporting and testing from existing Title V permit.

X Permit Shield

For all applicable requirements listed above, provide monitoring/testing/recordkeeping/reporting which shall be used to demonstrate compliance. If the method is based on a permit or rule, include the condition number or citation. (Note: Each requirement listed above must have an associated method of demonstrating compliance. If there is not already a required method in place, then a method must be proposed.)

See Attachment I for applicable requirements, monitoring, recordkeeping, reporting and testing from existing Title V permit.

Are you in compliance with all applicable requirements for this emission unit? X Yes No

If no, complete the **Schedule of Compliance Form** as **ATTACHMENT F**.

ATTACHMENT E - Emission Unit Form

Emission Unit Description: Storage Tank

Emission unit ID number: 8321	Emission unit name: Tank 8321	List any control devices associated with this emission unit:
---	---	---

Provide a description of the emission unit (type, method of operation, design parameters, etc.):

Storage of volatile organic liquid

Manufacturer:	Model number:	Serial number:
Construction date: See Attachment D Equipment Table	Installation date: See Attachment D Equipment Table	Modification date(s): See Attachment D Equipment Table

Design Capacity (examples: furnaces - tons/hr, tanks - gallons): See Attachment D Equipment Table

Maximum Hourly Throughput:	Maximum Annual Throughput:	Maximum Operating Schedule: 24 hrs/day, 365 days/yr
-----------------------------------	-----------------------------------	---

Fuel Usage Data (fill out all applicable fields)

Does this emission unit combust fuel? ___Yes <u>X</u> No	If yes, is it? ___ Indirect Fired ___ Direct Fired
Maximum design heat input and/or maximum horsepower rating:	Type and Btu/hr rating of burners:

List the primary fuel type(s) and if applicable, the secondary fuel type(s). For each fuel type listed, provide the maximum hourly and annual fuel usage for each.

Describe each fuel expected to be used during the term of the permit.

Fuel Type	Max. Sulfur Content	Max. Ash Content	BTU Value

Union Carbide Corporation South Charleston Facility – TRITON

<i>Emissions Data</i>		
Criteria Pollutants	Potential Emissions	
	PPH	TPY
Carbon Monoxide (CO)		
Nitrogen Oxides (NO _x)		
Lead (Pb)		
Particulate Matter (PM _{2.5})		
Particulate Matter (PM ₁₀)		
Total Particulate Matter (TSP)		
Sulfur Dioxide (SO ₂)		
Volatile Organic Compounds (VOC)		
Hazardous Air Pollutants	Potential Emissions	
	PPH	TPY
Regulated Pollutants other than Criteria and HAP	Potential Emissions	
	PPH	TPY

List the method(s) used to calculate the potential emissions (include dates of any stack tests conducted, versions of software used, source and dates of emission factors, etc.).

Applicable Requirements

List all applicable requirements for this emission unit. For each applicable requirement, include the underlying rule/regulation citation and/or construction permit with the condition number. (Note: Title V permit condition numbers alone are not the underlying applicable requirements). If an emission limit is calculated based on the type of source and design capacity or if a standard is based on a design parameter, this information should also be included.

See current Title V permit.

X Permit Shield

For all applicable requirements listed above, provide monitoring/testing/recordkeeping/reporting which shall be used to demonstrate compliance. If the method is based on a permit or rule, include the condition number or citation. (Note: Each requirement listed above must have an associated method of demonstrating compliance. If there is not already a required method in place, then a method must be proposed.)

See current Title V permit.

Are you in compliance with all applicable requirements for this emission unit? X Yes No

If no, complete the **Schedule of Compliance Form** as ATTACHMENT F.

ATTACHMENT E - Emission Unit Form

Emission Unit Description: Storage Tank			
Emission unit ID number: 8323	Emission unit name: Tank 8323	List any control devices associated with this emission unit:	
Provide a description of the emission unit (type, method of operation, design parameters, etc.): Storage of volatile organic liquid			
Manufacturer:	Model number:	Serial number:	
Construction date: See Attachment D Equipment Table	Installation date: See Attachment D Equipment Table	Modification date(s): See Attachment D Equipment Table	
Design Capacity (examples: furnaces - tons/hr, tanks - gallons): See Attachment D Equipment Table			
Maximum Hourly Throughput:	Maximum Annual Throughput:	Maximum Operating Schedule: 24 hrs/day, 365 days/yr	
Fuel Usage Data (fill out all applicable fields)			
Does this emission unit combust fuel? ___Yes <input checked="" type="checkbox"/> No		If yes, is it? ___ Indirect Fired ___ Direct Fired	
Maximum design heat input and/or maximum horsepower rating:		Type and Btu/hr rating of burners:	
List the primary fuel type(s) and if applicable, the secondary fuel type(s). For each fuel type listed, provide the maximum hourly and annual fuel usage for each.			
Describe each fuel expected to be used during the term of the permit.			
Fuel Type	Max. Sulfur Content	Max. Ash Content	BTU Value

Union Carbide Corporation South Charleston Facility – TRITON

<i>Emissions Data</i>		
Criteria Pollutants	Potential Emissions	
	PPH	TPY
Carbon Monoxide (CO)		
Nitrogen Oxides (NO _x)		
Lead (Pb)		
Particulate Matter (PM _{2.5})		
Particulate Matter (PM ₁₀)		
Total Particulate Matter (TSP)		
Sulfur Dioxide (SO ₂)		
Volatile Organic Compounds (VOC)		
Hazardous Air Pollutants	Potential Emissions	
	PPH	TPY
Regulated Pollutants other than Criteria and HAP	Potential Emissions	
	PPH	TPY

List the method(s) used to calculate the potential emissions (include dates of any stack tests conducted, versions of software used, source and dates of emission factors, etc.).

Applicable Requirements

List all applicable requirements for this emission unit. For each applicable requirement, include the underlying rule/regulation citation and/or construction permit with the condition number. (Note: Title V permit condition numbers alone are not the underlying applicable requirements). If an emission limit is calculated based on the type of source and design capacity or if a standard is based on a design parameter, this information should also be included.

See Attachment I for applicable requirements, monitoring, recordkeeping, reporting and testing from existing Title V permit.

Permit Shield

For all applicable requirements listed above, provide monitoring/testing/recordkeeping/reporting which shall be used to demonstrate compliance. If the method is based on a permit or rule, include the condition number or citation. (Note: Each requirement listed above must have an associated method of demonstrating compliance. If there is not already a required method in place, then a method must be proposed.)

See Attachment I for applicable requirements, monitoring, recordkeeping, reporting and testing from existing Title V permit.

Are you in compliance with all applicable requirements for this emission unit? Yes No

If no, complete the **Schedule of Compliance Form** as ATTACHMENT F.

ATTACHMENT E - Emission Unit Form

Emission Unit Description: Storage Tank			
Emission unit ID number: 8324	Emission unit name: Tank 8324	List any control devices associated with this emission unit:	
Provide a description of the emission unit (type, method of operation, design parameters, etc.): Storage of volatile organic liquid			
Manufacturer:	Model number:	Serial number:	
Construction date: See Attachment D Equipment Table	Installation date: See Attachment D Equipment Table	Modification date(s): See Attachment D Equipment Table	
Design Capacity (examples: furnaces - tons/hr, tanks - gallons): See Attachment D Equipment Table			
Maximum Hourly Throughput:	Maximum Annual Throughput:	Maximum Operating Schedule: 24 hrs/day, 365 days/yr	
Fuel Usage Data (fill out all applicable fields)			
Does this emission unit combust fuel? ___ Yes <input checked="" type="checkbox"/> No		If yes, is it? ___ Indirect Fired ___ Direct Fired	
Maximum design heat input and/or maximum horsepower rating:		Type and Btu/hr rating of burners:	
List the primary fuel type(s) and if applicable, the secondary fuel type(s). For each fuel type listed, provide the maximum hourly and annual fuel usage for each.			
Describe each fuel expected to be used during the term of the permit.			
Fuel Type	Max. Sulfur Content	Max. Ash Content	BTU Value

Union Carbide Corporation South Charleston Facility – TRITON

Emissions Data		
Criteria Pollutants	Potential Emissions	
	PPH	TPY
Carbon Monoxide (CO)		
Nitrogen Oxides (NO _x)		
Lead (Pb)		
Particulate Matter (PM _{2.5})		
Particulate Matter (PM ₁₀)		
Total Particulate Matter (TSP)		
Sulfur Dioxide (SO ₂)		
Volatile Organic Compounds (VOC)		
Hazardous Air Pollutants	Potential Emissions	
	PPH	TPY
Regulated Pollutants other than Criteria and HAP	Potential Emissions	
	PPH	TPY

List the method(s) used to calculate the potential emissions (include dates of any stack tests conducted, versions of software used, source and dates of emission factors, etc.).

Applicable Requirements

List all applicable requirements for this emission unit. For each applicable requirement, include the underlying rule/regulation citation and/or construction permit with the condition number. (Note: Title V permit condition numbers alone are not the underlying applicable requirements). If an emission limit is calculated based on the type of source and design capacity or if a standard is based on a design parameter, this information should also be included.

See Attachment I for applicable requirements, monitoring, recordkeeping, reporting and testing from existing Title V permit.

X Permit Shield

For all applicable requirements listed above, provide monitoring/testing/recordkeeping/reporting which shall be used to demonstrate compliance. If the method is based on a permit or rule, include the condition number or citation. (Note: Each requirement listed above must have an associated method of demonstrating compliance. If there is not already a required method in place, then a method must be proposed.)

See Attachment I for applicable requirements, monitoring, recordkeeping, reporting and testing from existing Title V permit.

Are you in compliance with all applicable requirements for this emission unit? X Yes No

If no, complete the **Schedule of Compliance Form** as **ATTACHMENT F**.

ATTACHMENT E - Emission Unit Form

Emission Unit Description: Storage Tank

Emission unit ID number: 8322	Emission unit name: Tank 8322	List any control devices associated with this emission unit:
---	---	---

Provide a description of the emission unit (type, method of operation, design parameters, etc.):

Storage of volatile organic liquid

Manufacturer:	Model number:	Serial number:
Construction date: See Attachment D Equipment Table	Installation date: See Attachment D Equipment Table	Modification date(s): See Attachment D Equipment Table

Design Capacity (examples: furnaces - tons/hr, tanks - gallons): See Attachment D Equipment Table

Maximum Hourly Throughput:	Maximum Annual Throughput:	Maximum Operating Schedule: 24 hrs/day, 365 days/yr
-----------------------------------	-----------------------------------	---

Fuel Usage Data (fill out all applicable fields)

Does this emission unit combust fuel? ___Yes <u>X</u> No	If yes, is it? ___ Indirect Fired ___ Direct Fired
Maximum design heat input and/or maximum horsepower rating:	Type and Btu/hr rating of burners:

List the primary fuel type(s) and if applicable, the secondary fuel type(s). For each fuel type listed, provide the maximum hourly and annual fuel usage for each.

Describe each fuel expected to be used during the term of the permit.

Fuel Type	Max. Sulfur Content	Max. Ash Content	BTU Value

Union Carbide Corporation South Charleston Facility – TRITON

<i>Emissions Data</i>		
Criteria Pollutants	Potential Emissions	
	PPH	TPY
Carbon Monoxide (CO)		
Nitrogen Oxides (NO _x)		
Lead (Pb)		
Particulate Matter (PM _{2.5})		
Particulate Matter (PM ₁₀)		
Total Particulate Matter (TSP)		
Sulfur Dioxide (SO ₂)		
Volatile Organic Compounds (VOC)		
Hazardous Air Pollutants	Potential Emissions	
	PPH	TPY
Regulated Pollutants other than Criteria and HAP	Potential Emissions	
	PPH	TPY

List the method(s) used to calculate the potential emissions (include dates of any stack tests conducted, versions of software used, source and dates of emission factors, etc.).

Applicable Requirements

List all applicable requirements for this emission unit. For each applicable requirement, include the underlying rule/regulation citation and/or construction permit with the condition number. (Note: Title V permit condition numbers alone are not the underlying applicable requirements). If an emission limit is calculated based on the type of source and design capacity or if a standard is based on a design parameter, this information should also be included.

See Attachment I for applicable requirements, monitoring, recordkeeping, reporting and testing from existing Title V permit.

Permit Shield

For all applicable requirements listed above, provide monitoring/testing/recordkeeping/reporting which shall be used to demonstrate compliance. If the method is based on a permit or rule, include the condition number or citation. (Note: Each requirement listed above must have an associated method of demonstrating compliance. If there is not already a required method in place, then a method must be proposed.)

See Attachment I for applicable requirements, monitoring, recordkeeping, reporting and testing from existing Title V permit.

Are you in compliance with all applicable requirements for this emission unit? Yes No

If no, complete the **Schedule of Compliance Form** as ATTACHMENT F.

ATTACHMENT E - Emission Unit Form

Emission Unit Description: Storage Tank

Emission unit ID number: 8314	Emission unit name: Tank 8314	List any control devices associated with this emission unit:
---	---	---

Provide a description of the emission unit (type, method of operation, design parameters, etc.):
Storage of volatile organic liquid

Manufacturer:	Model number:	Serial number:
----------------------	----------------------	-----------------------

Construction date: See Attachment D Equipment Table	Installation date: See Attachment D Equipment Table	Modification date(s): See Attachment D Equipment Table
---	---	--

Design Capacity (examples: furnaces - tons/hr, tanks - gallons): See Attachment D Equipment Table

Maximum Hourly Throughput:	Maximum Annual Throughput:	Maximum Operating Schedule: 24 hrs/day, 365 days/yr
-----------------------------------	-----------------------------------	---

Fuel Usage Data (fill out all applicable fields)

Does this emission unit combust fuel? ___ Yes <u> X </u> No	If yes, is it? ___ Indirect Fired ___ Direct Fired
--	--

Maximum design heat input and/or maximum horsepower rating:	Type and Btu/hr rating of burners:
--	---

List the primary fuel type(s) and if applicable, the secondary fuel type(s). For each fuel type listed, provide the maximum hourly and annual fuel usage for each.

Describe each fuel expected to be used during the term of the permit.

Fuel Type	Max. Sulfur Content	Max. Ash Content	BTU Value

Union Carbide Corporation South Charleston Facility – TRITON

<i>Emissions Data</i>		
Criteria Pollutants	Potential Emissions	
	PPH	TPY
Carbon Monoxide (CO)		
Nitrogen Oxides (NO _x)		
Lead (Pb)		
Particulate Matter (PM _{2.5})		
Particulate Matter (PM ₁₀)		
Total Particulate Matter (TSP)		
Sulfur Dioxide (SO ₂)		
Volatile Organic Compounds (VOC)		
Hazardous Air Pollutants	Potential Emissions	
	PPH	TPY
Regulated Pollutants other than Criteria and HAP	Potential Emissions	
	PPH	TPY

List the method(s) used to calculate the potential emissions (include dates of any stack tests conducted, versions of software used, source and dates of emission factors, etc.).

Applicable Requirements

List all applicable requirements for this emission unit. For each applicable requirement, include the underlying rule/regulation citation and/or **construction permit** with the condition number. (Note: Title V permit condition numbers alone are not the underlying applicable requirements). If an emission limit is calculated based on the type of source and design capacity or if a standard is based on a design parameter, this information should also be included.

See current Title V permit.

Permit Shield

For all applicable requirements listed above, provide monitoring/testing/recordkeeping/reporting which shall be used to demonstrate compliance. If the method is based on a permit or rule, include the condition number or citation. (Note: Each requirement listed above must have an associated method of demonstrating compliance. If there is not already a required method in place, then a method must be proposed.)

See current Title V permit.

Are you in compliance with all applicable requirements for this emission unit? Yes No

If no, complete the **Schedule of Compliance Form** as ATTACHMENT F.

ATTACHMENT E - Emission Unit Form

Emission Unit Description: Storage Tank

Emission unit ID number: 8320	Emission unit name: Tank 8320	List any control devices associated with this emission unit:
---	---	---

Provide a description of the emission unit (type, method of operation, design parameters, etc.):

Storage of volatile organic liquid

Manufacturer:	Model number:	Serial number:
Construction date: See Attachment D Equipment Table	Installation date: See Attachment D Equipment Table	Modification date(s): See Attachment D Equipment Table

Design Capacity (examples: furnaces - tons/hr, tanks - gallons): See Attachment D Equipment Table

Maximum Hourly Throughput:	Maximum Annual Throughput:	Maximum Operating Schedule: 24 hrs/day, 365 days/yr
-----------------------------------	-----------------------------------	---

Fuel Usage Data (fill out all applicable fields)

Does this emission unit combust fuel? ___Yes <u>X</u> No	If yes, is it? ___ Indirect Fired ___ Direct Fired
Maximum design heat input and/or maximum horsepower rating:	Type and Btu/hr rating of burners:

List the primary fuel type(s) and if applicable, the secondary fuel type(s). For each fuel type listed, provide the maximum hourly and annual fuel usage for each.

Describe each fuel expected to be used during the term of the permit.

Fuel Type	Max. Sulfur Content	Max. Ash Content	BTU Value

Union Carbide Corporation South Charleston Facility – TRITON

<i>Emissions Data</i>		
Criteria Pollutants	Potential Emissions	
	PPH	TPY
Carbon Monoxide (CO)		
Nitrogen Oxides (NO _x)		
Lead (Pb)		
Particulate Matter (PM _{2.5})		
Particulate Matter (PM ₁₀)		
Total Particulate Matter (TSP)		
Sulfur Dioxide (SO ₂)		
Volatile Organic Compounds (VOC)		
Hazardous Air Pollutants	Potential Emissions	
	PPH	TPY
Regulated Pollutants other than Criteria and HAP	Potential Emissions	
	PPH	TPY

List the method(s) used to calculate the potential emissions (include dates of any stack tests conducted, versions of software used, source and dates of emission factors, etc.).

Applicable Requirements

List all applicable requirements for this emission unit. For each applicable requirement, include the underlying rule/regulation citation and/or construction permit with the condition number. (Note: Title V permit condition numbers alone are not the underlying applicable requirements). If an emission limit is calculated based on the type of source and design capacity or if a standard is based on a design parameter, this information should also be included.

See current Title V permit.

X Permit Shield

For all applicable requirements listed above, provide monitoring/testing/recordkeeping/reporting which shall be used to demonstrate compliance. If the method is based on a permit or rule, include the condition number or citation. (Note: Each requirement listed above must have an associated method of demonstrating compliance. If there is not already a required method in place, then a method must be proposed.)

See current Title V permit.

Are you in compliance with all applicable requirements for this emission unit? X Yes No

If no, complete the **Schedule of Compliance Form** as ATTACHMENT F.

ATTACHMENT E - Emission Unit Form

Emission Unit Description: Vessel

Emission unit ID number: 8101	Emission unit name: Vessel 8101	List any control devices associated with this emission unit:
---	---	---

Provide a description of the emission unit (type, method of operation, design parameters, etc.):

Storage of volatile organic liquid

Manufacturer:	Model number:	Serial number:
Construction date: See Attachment D Equipment Table	Installation date: See Attachment D Equipment Table	Modification date(s): See Attachment D Equipment Table

Design Capacity (examples: furnaces - tons/hr, tanks - gallons): See Attachment D Equipment Table

Maximum Hourly Throughput:	Maximum Annual Throughput:	Maximum Operating Schedule: 24 hrs/day, 365 days/yr
-----------------------------------	-----------------------------------	---

Fuel Usage Data (fill out all applicable fields)

Does this emission unit combust fuel? ___Yes <u>X</u> No	If yes, is it? ___ Indirect Fired ___ Direct Fired
Maximum design heat input and/or maximum horsepower rating:	Type and Btu/hr rating of burners:

List the primary fuel type(s) and if applicable, the secondary fuel type(s). For each fuel type listed, provide the maximum hourly and annual fuel usage for each.

Describe each fuel expected to be used during the term of the permit.

Fuel Type	Max. Sulfur Content	Max. Ash Content	BTU Value

Union Carbide Corporation South Charleston Facility – TRITON

<i>Emissions Data</i>		
Criteria Pollutants	Potential Emissions	
	PPH	TPY
Carbon Monoxide (CO)		
Nitrogen Oxides (NO _x)		
Lead (Pb)		
Particulate Matter (PM _{2.5})		
Particulate Matter (PM ₁₀)		
Total Particulate Matter (TSP)		
Sulfur Dioxide (SO ₂)		
Volatile Organic Compounds (VOC)		
Hazardous Air Pollutants	Potential Emissions	
	PPH	TPY
Regulated Pollutants other than Criteria and HAP	Potential Emissions	
	PPH	TPY

List the method(s) used to calculate the potential emissions (include dates of any stack tests conducted, versions of software used, source and dates of emission factors, etc.).

Applicable Requirements

List all applicable requirements for this emission unit. For each applicable requirement, include the underlying rule/regulation citation and/or construction permit with the condition number. (Note: Title V permit condition numbers alone are not the underlying applicable requirements). If an emission limit is calculated based on the type of source and design capacity or if a standard is based on a design parameter, this information should also be included.

See current Title V permit.

X Permit Shield

For all applicable requirements listed above, provide monitoring/testing/recordkeeping/reporting which shall be used to demonstrate compliance. If the method is based on a permit or rule, include the condition number or citation. (Note: Each requirement listed above must have an associated method of demonstrating compliance. If there is not already a required method in place, then a method must be proposed.)

See current Title V permit.

Are you in compliance with all applicable requirements for this emission unit? X Yes No

If no, complete the **Schedule of Compliance Form** as ATTACHMENT F.

ATTACHMENT E - Emission Unit Form

Emission Unit Description: Storage Tank

Emission unit ID number: 8313	Emission unit name: Tank 8313	List any control devices associated with this emission unit:
---	---	---

Provide a description of the emission unit (type, method of operation, design parameters, etc.):

Storage of volatile organic liquid

Manufacturer:	Model number:	Serial number:
Construction date: See Attachment D Equipment Table	Installation date: See Attachment D Equipment Table	Modification date(s): See Attachment D Equipment Table

Design Capacity (examples: furnaces - tons/hr, tanks - gallons): See Attachment D Equipment Table

Maximum Hourly Throughput:	Maximum Annual Throughput:	Maximum Operating Schedule: 24 hrs/day, 365 days/yr
-----------------------------------	-----------------------------------	---

Fuel Usage Data (fill out all applicable fields)

Does this emission unit combust fuel? ___Yes <u>X</u> No	If yes, is it? ___ Indirect Fired ___ Direct Fired
Maximum design heat input and/or maximum horsepower rating:	Type and Btu/hr rating of burners:

List the primary fuel type(s) and if applicable, the secondary fuel type(s). For each fuel type listed, provide the maximum hourly and annual fuel usage for each.

Describe each fuel expected to be used during the term of the permit.

Fuel Type	Max. Sulfur Content	Max. Ash Content	BTU Value

Union Carbide Corporation South Charleston Facility – TRITON

<i>Emissions Data</i>		
Criteria Pollutants	Potential Emissions	
	PPH	TPY
Carbon Monoxide (CO)		
Nitrogen Oxides (NO _x)		
Lead (Pb)		
Particulate Matter (PM _{2.5})		
Particulate Matter (PM ₁₀)		
Total Particulate Matter (TSP)		
Sulfur Dioxide (SO ₂)		
Volatile Organic Compounds (VOC)		
Hazardous Air Pollutants	Potential Emissions	
	PPH	TPY
Regulated Pollutants other than Criteria and HAP	Potential Emissions	
	PPH	TPY

List the method(s) used to calculate the potential emissions (include dates of any stack tests conducted, versions of software used, source and dates of emission factors, etc.).

Applicable Requirements

List all applicable requirements for this emission unit. For each applicable requirement, include the underlying rule/regulation citation and/or construction permit with the condition number. (Note: Title V permit condition numbers alone are not the underlying applicable requirements). If an emission limit is calculated based on the type of source and design capacity or if a standard is based on a design parameter, this information should also be included.

See current Title V permit.

X Permit Shield

For all applicable requirements listed above, provide monitoring/testing/recordkeeping/reporting which shall be used to demonstrate compliance. If the method is based on a permit or rule, include the condition number or citation. (Note: Each requirement listed above must have an associated method of demonstrating compliance. If there is not already a required method in place, then a method must be proposed.)

See current Title V permit.

Are you in compliance with all applicable requirements for this emission unit? X Yes No

If no, complete the **Schedule of Compliance Form** as ATTACHMENT F.

ATTACHMENT E - Emission Unit Form

Emission Unit Description: Reactor

Emission unit ID number: 8800	Emission unit name: 8800 Reactor	List any control devices associated with this emission unit: C8130 or none
---	--	--

Provide a description of the emission unit (type, method of operation, design parameters, etc.):

Manufacturer:	Model number:	Serial number:
----------------------	----------------------	-----------------------

Construction date: See Attachment D Equipment Table	Installation date: See Attachment D Equipment Table	Modification date(s): See Attachment D Equipment Table
---	---	--

Design Capacity (examples: furnaces - tons/hr, tanks - gallons): See Attachment D Equipment Table

Maximum Hourly Throughput:	Maximum Annual Throughput:	Maximum Operating Schedule: 24 hrs/day, 365 days/yr
-----------------------------------	-----------------------------------	---

Fuel Usage Data (fill out all applicable fields)

Does this emission unit combust fuel? ___ Yes <u> X </u> No	If yes, is it? ___ Indirect Fired ___ Direct Fired
--	--

Maximum design heat input and/or maximum horsepower rating:	Type and Btu/hr rating of burners:
--	---

List the primary fuel type(s) and if applicable, the secondary fuel type(s). For each fuel type listed, provide the maximum hourly and annual fuel usage for each.

Describe each fuel expected to be used during the term of the permit.

Fuel Type	Max. Sulfur Content	Max. Ash Content	BTU Value

Union Carbide Corporation South Charleston Facility – TRITON

<i>Emissions Data</i>		
Criteria Pollutants	Potential Emissions	
	PPH	TPY
Carbon Monoxide (CO)		
Nitrogen Oxides (NO _x)		
Lead (Pb)		
Particulate Matter (PM _{2.5})		
Particulate Matter (PM ₁₀)		
Total Particulate Matter (TSP)		
Sulfur Dioxide (SO ₂)		
Volatile Organic Compounds (VOC)		
Hazardous Air Pollutants	Potential Emissions	
	PPH	TPY
Regulated Pollutants other than Criteria and HAP	Potential Emissions	
	PPH	TPY

List the method(s) used to calculate the potential emissions (include dates of any stack tests conducted, versions of software used, source and dates of emission factors, etc.).

Applicable Requirements

List all applicable requirements for this emission unit. For each applicable requirement, include the underlying rule/regulation citation and/or construction permit with the condition number. (Note: Title V permit condition numbers alone are not the underlying applicable requirements). If an emission limit is calculated based on the type of source and design capacity or if a standard is based on a design parameter, this information should also be included.

See Attachment I for applicable requirements, monitoring, recordkeeping, reporting and testing from existing Title V permit.

X Permit Shield

For all applicable requirements listed above, provide monitoring/testing/recordkeeping/reporting which shall be used to demonstrate compliance. If the method is based on a permit or rule, include the condition number or citation. (Note: Each requirement listed above must have an associated method of demonstrating compliance. If there is not already a required method in place, then a method must be proposed.)

See Attachment I for applicable requirements, monitoring, recordkeeping, reporting and testing from existing Title V permit.

Are you in compliance with all applicable requirements for this emission unit? X Yes No

If no, complete the **Schedule of Compliance Form** as **ATTACHMENT F**.

ATTACHMENT E - Emission Unit Form

Emission Unit Description: Storage Tank

Emission unit ID number: 8621	Emission unit name: Tank 8621	List any control devices associated with this emission unit: C8130
---	---	--

Provide a description of the emission unit (type, method of operation, design parameters, etc.):
Storage of volatile organic compounds

Manufacturer:	Model number:	Serial number:
----------------------	----------------------	-----------------------

Construction date: See Attachment D Equipment Table	Installation date: See Attachment D Equipment Table	Modification date(s): See Attachment D Equipment Table
---	---	--

Design Capacity (examples: furnaces - tons/hr, tanks - gallons): See Attachment D Equipment Table

Maximum Hourly Throughput:	Maximum Annual Throughput:	Maximum Operating Schedule: 24 hrs/day, 365 days/yr
-----------------------------------	-----------------------------------	---

Fuel Usage Data (fill out all applicable fields)

Does this emission unit combust fuel? ___Yes <u>X</u> No	If yes, is it? ___ Indirect Fired ___Direct Fired
---	---

Maximum design heat input and/or maximum horsepower rating:	Type and Btu/hr rating of burners:
--	---

List the primary fuel type(s) and if applicable, the secondary fuel type(s). For each fuel type listed, provide the maximum hourly and annual fuel usage for each.

Describe each fuel expected to be used during the term of the permit.

Fuel Type	Max. Sulfur Content	Max. Ash Content	BTU Value

Union Carbide Corporation South Charleston Facility – TRITON

<i>Emissions Data</i>		
Criteria Pollutants	Potential Emissions	
	PPH	TPY
Carbon Monoxide (CO)		
Nitrogen Oxides (NO _x)		
Lead (Pb)		
Particulate Matter (PM _{2.5})		
Particulate Matter (PM ₁₀)		
Total Particulate Matter (TSP)		
Sulfur Dioxide (SO ₂)		
Volatile Organic Compounds (VOC)		
Hazardous Air Pollutants	Potential Emissions	
	PPH	TPY
Regulated Pollutants other than Criteria and HAP	Potential Emissions	
	PPH	TPY

List the method(s) used to calculate the potential emissions (include dates of any stack tests conducted, versions of software used, source and dates of emission factors, etc.).

Applicable Requirements

List all applicable requirements for this emission unit. For each applicable requirement, include the underlying rule/regulation citation and/or construction permit with the condition number. (Note: Title V permit condition numbers alone are not the underlying applicable requirements). If an emission limit is calculated based on the type of source and design capacity or if a standard is based on a design parameter, this information should also be included.

See Attachment I for applicable requirements, monitoring, recordkeeping, reporting and testing from existing Title V permit.

X Permit Shield

For all applicable requirements listed above, provide monitoring/testing/recordkeeping/reporting which shall be used to demonstrate compliance. If the method is based on a permit or rule, include the condition number or citation. (Note: Each requirement listed above must have an associated method of demonstrating compliance. If there is not already a required method in place, then a method must be proposed.)

See Attachment I for applicable requirements, monitoring, recordkeeping, reporting and testing from existing Title V permit.

Are you in compliance with all applicable requirements for this emission unit? X Yes No

If no, complete the **Schedule of Compliance Form** as **ATTACHMENT F**.

ATTACHMENT E - Emission Unit Form

Emission Unit Description: Storage Tank

Emission unit ID number: 8540	Emission unit name: Tank 8540	List any control devices associated with this emission unit: C8110 and C8130
---	---	--

Provide a description of the emission unit (type, method of operation, design parameters, etc.):
Storage of volatile organic compounds

Manufacturer:	Model number:	Serial number:
----------------------	----------------------	-----------------------

Construction date: See Attachment D Equipment Table	Installation date: See Attachment D Equipment Table	Modification date(s): See Attachment D Equipment Table
---	---	--

Design Capacity (examples: furnaces - tons/hr, tanks - gallons): See Attachment D Equipment Table

Maximum Hourly Throughput:	Maximum Annual Throughput:	Maximum Operating Schedule: 24 hrs/day, 365 days/yr
-----------------------------------	-----------------------------------	---

Fuel Usage Data (fill out all applicable fields)

Does this emission unit combust fuel? ___Yes <u>X</u> No	If yes, is it? ___ Indirect Fired ___Direct Fired
---	---

Maximum design heat input and/or maximum horsepower rating:	Type and Btu/hr rating of burners:
--	---

List the primary fuel type(s) and if applicable, the secondary fuel type(s). For each fuel type listed, provide the maximum hourly and annual fuel usage for each.

Describe each fuel expected to be used during the term of the permit.

Fuel Type	Max. Sulfur Content	Max. Ash Content	BTU Value

Union Carbide Corporation South Charleston Facility – TRITON

<i>Emissions Data</i>		
Criteria Pollutants	Potential Emissions	
	PPH	TPY
Carbon Monoxide (CO)		
Nitrogen Oxides (NO _x)		
Lead (Pb)		
Particulate Matter (PM _{2.5})		
Particulate Matter (PM ₁₀)		
Total Particulate Matter (TSP)		
Sulfur Dioxide (SO ₂)		
Volatile Organic Compounds (VOC)		
Hazardous Air Pollutants	Potential Emissions	
	PPH	TPY
Regulated Pollutants other than Criteria and HAP	Potential Emissions	
	PPH	TPY

List the method(s) used to calculate the potential emissions (include dates of any stack tests conducted, versions of software used, source and dates of emission factors, etc.).

Applicable Requirements

List all applicable requirements for this emission unit. For each applicable requirement, include the underlying rule/regulation citation and/or construction permit with the condition number. (Note: Title V permit condition numbers alone are not the underlying applicable requirements). If an emission limit is calculated based on the type of source and design capacity or if a standard is based on a design parameter, this information should also be included.

See Attachment I for applicable requirements, monitoring, recordkeeping, reporting and testing from existing Title V permit.

X Permit Shield

For all applicable requirements listed above, provide monitoring/testing/recordkeeping/reporting which shall be used to demonstrate compliance. If the method is based on a permit or rule, include the condition number or citation. (Note: Each requirement listed above must have an associated method of demonstrating compliance. If there is not already a required method in place, then a method must be proposed.)

See Attachment I for applicable requirements, monitoring, recordkeeping, reporting and testing from existing Title V permit.

Are you in compliance with all applicable requirements for this emission unit? X Yes No

If no, complete the **Schedule of Compliance Form** as **ATTACHMENT F**.

ATTACHMENT E - Emission Unit Form

Emission Unit Description: Storage Tank

Emission unit ID number: 8528	Emission unit name: Tank 8528	List any control devices associated with this emission unit: C8110 and C8130
---	---	--

Provide a description of the emission unit (type, method of operation, design parameters, etc.):
Storage of volatile organic compounds

Manufacturer:	Model number:	Serial number:
----------------------	----------------------	-----------------------

Construction date: See Attachment D Equipment Table	Installation date: See Attachment D Equipment Table	Modification date(s): See Attachment D Equipment Table
---	---	--

Design Capacity (examples: furnaces - tons/hr, tanks - gallons): See Attachment D Equipment Table

Maximum Hourly Throughput:	Maximum Annual Throughput:	Maximum Operating Schedule: 24 hrs/day, 365 days/yr
-----------------------------------	-----------------------------------	---

Fuel Usage Data (fill out all applicable fields)

Does this emission unit combust fuel? ___Yes <u>X</u> No	If yes, is it? ___ Indirect Fired ___Direct Fired
---	---

Maximum design heat input and/or maximum horsepower rating:	Type and Btu/hr rating of burners:
--	---

List the primary fuel type(s) and if applicable, the secondary fuel type(s). For each fuel type listed, provide the maximum hourly and annual fuel usage for each.

Describe each fuel expected to be used during the term of the permit.

Fuel Type	Max. Sulfur Content	Max. Ash Content	BTU Value

Union Carbide Corporation South Charleston Facility – TRITON

<i>Emissions Data</i>		
Criteria Pollutants	Potential Emissions	
	PPH	TPY
Carbon Monoxide (CO)		
Nitrogen Oxides (NO _x)		
Lead (Pb)		
Particulate Matter (PM _{2.5})		
Particulate Matter (PM ₁₀)		
Total Particulate Matter (TSP)		
Sulfur Dioxide (SO ₂)		
Volatile Organic Compounds (VOC)		
Hazardous Air Pollutants	Potential Emissions	
	PPH	TPY
Regulated Pollutants other than Criteria and HAP	Potential Emissions	
	PPH	TPY

List the method(s) used to calculate the potential emissions (include dates of any stack tests conducted, versions of software used, source and dates of emission factors, etc.).

Applicable Requirements

List all applicable requirements for this emission unit. For each applicable requirement, include the underlying rule/regulation citation and/or construction permit with the condition number. (Note: Title V permit condition numbers alone are not the underlying applicable requirements). If an emission limit is calculated based on the type of source and design capacity or if a standard is based on a design parameter, this information should also be included.

See Attachment I for applicable requirements, monitoring, recordkeeping, reporting and testing from existing Title V permit.

X Permit Shield

For all applicable requirements listed above, provide monitoring/testing/recordkeeping/reporting which shall be used to demonstrate compliance. If the method is based on a permit or rule, include the condition number or citation. (Note: Each requirement listed above must have an associated method of demonstrating compliance. If there is not already a required method in place, then a method must be proposed.)

See Attachment I for applicable requirements, monitoring, recordkeeping, reporting and testing from existing Title V permit.

Are you in compliance with all applicable requirements for this emission unit? X Yes No

If no, complete the **Schedule of Compliance Form** as **ATTACHMENT F**.

ATTACHMENT E - Emission Unit Form

Emission Unit Description: Reactor

Emission unit ID number: 8500	Emission unit name: 8500 Reactor	List any control devices associated with this emission unit: C8110 or C8110 and C8130 or none	
Provide a description of the emission unit (type, method of operation, design parameters, etc.): Reactor			
Manufacturer:	Model number:	Serial number:	
Construction date: See Attachment D Equipment Table	Installation date: See Attachment D Equipment Table	Modification date(s): See Attachment D Equipment Table	
Design Capacity (examples: furnaces - tons/hr, tanks - gallons): See Attachment D Equipment Table			
Maximum Hourly Throughput:	Maximum Annual Throughput:	Maximum Operating Schedule: 24 hrs/day, 365 days/yr	
Fuel Usage Data (fill out all applicable fields)			
Does this emission unit combust fuel? ___ Yes <input checked="" type="checkbox"/> No		If yes, is it? ___ Indirect Fired ___ Direct Fired	
Maximum design heat input and/or maximum horsepower rating:		Type and Btu/hr rating of burners:	
List the primary fuel type(s) and if applicable, the secondary fuel type(s). For each fuel type listed, provide the maximum hourly and annual fuel usage for each.			
Describe each fuel expected to be used during the term of the permit.			
Fuel Type	Max. Sulfur Content	Max. Ash Content	BTU Value

Union Carbide Corporation South Charleston Facility – TRITON

Emissions Data		
Criteria Pollutants	Potential Emissions	
	PPH	TPY
Carbon Monoxide (CO)		
Nitrogen Oxides (NO _x)		
Lead (Pb)		
Particulate Matter (PM _{2.5})		
Particulate Matter (PM ₁₀)		
Total Particulate Matter (TSP)		
Sulfur Dioxide (SO ₂)		
Volatile Organic Compounds (VOC)		
Hazardous Air Pollutants	Potential Emissions	
	PPH	TPY
Regulated Pollutants other than Criteria and HAP	Potential Emissions	
	PPH	TPY

List the method(s) used to calculate the potential emissions (include dates of any stack tests conducted, versions of software used, source and dates of emission factors, etc.).

Applicable Requirements

List all applicable requirements for this emission unit. For each applicable requirement, include the underlying rule/regulation citation and/or construction permit with the condition number. (Note: Title V permit condition numbers alone are not the underlying applicable requirements). If an emission limit is calculated based on the type of source and design capacity or if a standard is based on a design parameter, this information should also be included.

See Attachment I for applicable requirements, monitoring, recordkeeping, reporting and testing from existing Title V permit.

X Permit Shield

For all applicable requirements listed above, provide monitoring/testing/recordkeeping/reporting which shall be used to demonstrate compliance. If the method is based on a permit or rule, include the condition number or citation. (Note: Each requirement listed above must have an associated method of demonstrating compliance. If there is not already a required method in place, then a method must be proposed.)

See Attachment I for applicable requirements, monitoring, recordkeeping, reporting and testing from existing Title V permit.

Are you in compliance with all applicable requirements for this emission unit? X Yes No

If no, complete the **Schedule of Compliance Form** as **ATTACHMENT F**.

ATTACHMENT E - Emission Unit Form

Emission Unit Description: Storage Tank

Emission unit ID number: 8310	Emission unit name: Tank 8310	List any control devices associated with this emission unit: C8110 and C8130
---	---	--

Provide a description of the emission unit (type, method of operation, design parameters, etc.):
Storage of volatile organic liquid

Manufacturer:	Model number:	Serial number:
----------------------	----------------------	-----------------------

Construction date: See Attachment D Equipment Table	Installation date: See Attachment D Equipment Table	Modification date(s): See Attachment D Equipment Table
---	---	--

Design Capacity (examples: furnaces - tons/hr, tanks - gallons): See Attachment D Equipment Table

Maximum Hourly Throughput:	Maximum Annual Throughput:	Maximum Operating Schedule: 24 hrs/day, 365 days/yr
-----------------------------------	-----------------------------------	---

Fuel Usage Data (fill out all applicable fields)

Does this emission unit combust fuel? ___Yes <u>X</u> No	If yes, is it? ___ Indirect Fired ___ Direct Fired
---	--

Maximum design heat input and/or maximum horsepower rating:	Type and Btu/hr rating of burners:
--	---

List the primary fuel type(s) and if applicable, the secondary fuel type(s). For each fuel type listed, provide the maximum hourly and annual fuel usage for each.

Describe each fuel expected to be used during the term of the permit.

Fuel Type	Max. Sulfur Content	Max. Ash Content	BTU Value

Union Carbide Corporation South Charleston Facility – TRITON

<i>Emissions Data</i>		
Criteria Pollutants	Potential Emissions	
	PPH	TPY
Carbon Monoxide (CO)		
Nitrogen Oxides (NO _x)		
Lead (Pb)		
Particulate Matter (PM _{2.5})		
Particulate Matter (PM ₁₀)		
Total Particulate Matter (TSP)		
Sulfur Dioxide (SO ₂)		
Volatile Organic Compounds (VOC)		
Hazardous Air Pollutants	Potential Emissions	
	PPH	TPY
Regulated Pollutants other than Criteria and HAP	Potential Emissions	
	PPH	TPY

List the method(s) used to calculate the potential emissions (include dates of any stack tests conducted, versions of software used, source and dates of emission factors, etc.).

Applicable Requirements

List all applicable requirements for this emission unit. For each applicable requirement, include the underlying rule/regulation citation and/or construction permit with the condition number. (Note: Title V permit condition numbers alone are not the underlying applicable requirements). If an emission limit is calculated based on the type of source and design capacity or if a standard is based on a design parameter, this information should also be included.

See current Title V permit.

X Permit Shield

For all applicable requirements listed above, provide monitoring/testing/recordkeeping/reporting which shall be used to demonstrate compliance. If the method is based on a permit or rule, include the condition number or citation. (Note: Each requirement listed above must have an associated method of demonstrating compliance. If there is not already a required method in place, then a method must be proposed.)

See current Title V permit.

Are you in compliance with all applicable requirements for this emission unit? X Yes No

If no, complete the **Schedule of Compliance Form** as ATTACHMENT F.

ATTACHMENT E - Emission Unit Form

Emission Unit Description: Transfer Rack

Emission unit ID number: L1004	Emission unit name: Loading Rack L1004	List any control devices associated with this emission unit: N/A
--	--	--

Provide a description of the emission unit (type, method of operation, design parameters, etc.):

Manufacturer:	Model number:	Serial number:
----------------------	----------------------	-----------------------

Construction date: See Attachment D Equipment Table	Installation date: See Attachment D Equipment Table	Modification date(s): See Attachment D Equipment Table
---	---	--

Design Capacity (examples: furnaces - tons/hr, tanks - gallons): See Attachment D Equipment Table

Maximum Hourly Throughput:	Maximum Annual Throughput:	Maximum Operating Schedule: 24 hrs/day, 365 days/yr
-----------------------------------	-----------------------------------	---

Fuel Usage Data (fill out all applicable fields)

Does this emission unit combust fuel? ___ Yes <u> X </u> No	If yes, is it? ___ Indirect Fired ___ Direct Fired
--	--

Maximum design heat input and/or maximum horsepower rating:	Type and Btu/hr rating of burners:
--	---

List the primary fuel type(s) and if applicable, the secondary fuel type(s). For each fuel type listed, provide the maximum hourly and annual fuel usage for each.

Describe each fuel expected to be used during the term of the permit.

Fuel Type	Max. Sulfur Content	Max. Ash Content	BTU Value

Union Carbide Corporation South Charleston Facility – TRITON

<i>Emissions Data</i>		
Criteria Pollutants	Potential Emissions	
	PPH	TPY
Carbon Monoxide (CO)		
Nitrogen Oxides (NO _x)		
Lead (Pb)		
Particulate Matter (PM _{2.5})		
Particulate Matter (PM ₁₀)		
Total Particulate Matter (TSP)		
Sulfur Dioxide (SO ₂)		
Volatile Organic Compounds (VOC)		
Hazardous Air Pollutants	Potential Emissions	
	PPH	TPY
Regulated Pollutants other than Criteria and HAP	Potential Emissions	
	PPH	TPY

List the method(s) used to calculate the potential emissions (include dates of any stack tests conducted, versions of software used, source and dates of emission factors, etc.).

Applicable Requirements

List all applicable requirements for this emission unit. For each applicable requirement, include the underlying rule/regulation citation and/or construction permit with the condition number. (Note: Title V permit condition numbers alone are not the underlying applicable requirements). If an emission limit is calculated based on the type of source and design capacity or if a standard is based on a design parameter, this information should also be included.

See current Title V permit.

X Permit Shield

For all applicable requirements listed above, provide monitoring/testing/recordkeeping/reporting which shall be used to demonstrate compliance. If the method is based on a permit or rule, include the condition number or citation. (Note: Each requirement listed above must have an associated method of demonstrating compliance. If there is not already a required method in place, then a method must be proposed.)

See Attachment I for applicable requirements, monitoring, recordkeeping, reporting and testing from existing Title V permit.

Are you in compliance with all applicable requirements for this emission unit? X Yes No

If no, complete the **Schedule of Compliance Form** as ATTACHMENT F.

ATTACHMENT E - Emission Unit Form

Emission Unit Description: Transfer Rack

Emission unit ID number: L1005	Emission unit name: Loading Rack L1005	List any control devices associated with this emission unit: N/A
--	--	--

Provide a description of the emission unit (type, method of operation, design parameters, etc.):

Manufacturer:	Model number:	Serial number:
Construction date: See Attachment D Equipment Table	Installation date: See Attachment D Equipment Table	Modification date(s): See Attachment D Equipment Table

Design Capacity (examples: furnaces - tons/hr, tanks - gallons): See Attachment D Equipment Table

Maximum Hourly Throughput:	Maximum Annual Throughput:	Maximum Operating Schedule: 24 hrs/day, 365 days/yr
-----------------------------------	-----------------------------------	---

Fuel Usage Data (fill out all applicable fields)

Does this emission unit combust fuel? ___ Yes <input checked="" type="checkbox"/> No	If yes, is it? ___ Indirect Fired ___ Direct Fired
---	--

Maximum design heat input and/or maximum horsepower rating:	Type and Btu/hr rating of burners:
--	---

List the primary fuel type(s) and if applicable, the secondary fuel type(s). For each fuel type listed, provide the maximum hourly and annual fuel usage for each.

Describe each fuel expected to be used during the term of the permit.

Fuel Type	Max. Sulfur Content	Max. Ash Content	BTU Value

Union Carbide Corporation South Charleston Facility – TRITON

<i>Emissions Data</i>		
Criteria Pollutants	Potential Emissions	
	PPH	TPY
Carbon Monoxide (CO)		
Nitrogen Oxides (NO _x)		
Lead (Pb)		
Particulate Matter (PM _{2.5})		
Particulate Matter (PM ₁₀)		
Total Particulate Matter (TSP)		
Sulfur Dioxide (SO ₂)		
Volatile Organic Compounds (VOC)		
Hazardous Air Pollutants	Potential Emissions	
	PPH	TPY
Regulated Pollutants other than Criteria and HAP	Potential Emissions	
	PPH	TPY

List the method(s) used to calculate the potential emissions (include dates of any stack tests conducted, versions of software used, source and dates of emission factors, etc.).

Applicable Requirements

List all applicable requirements for this emission unit. For each applicable requirement, include the underlying rule/regulation citation and/or construction permit with the condition number. (Note: Title V permit condition numbers alone are not the underlying applicable requirements). If an emission limit is calculated based on the type of source and design capacity or if a standard is based on a design parameter, this information should also be included.

See Attachment I for applicable requirements, monitoring, recordkeeping, reporting and testing from existing Title V permit.

X Permit Shield

For all applicable requirements listed above, provide monitoring/testing/recordkeeping/reporting which shall be used to demonstrate compliance. If the method is based on a permit or rule, include the condition number or citation. (Note: Each requirement listed above must have an associated method of demonstrating compliance. If there is not already a required method in place, then a method must be proposed.)

See Attachment I for applicable requirements, monitoring, recordkeeping, reporting and testing from existing Title V permit.

Are you in compliance with all applicable requirements for this emission unit? X Yes No

If no, complete the **Schedule of Compliance Form** as **ATTACHMENT F**.

ATTACHMENT E - Emission Unit Form

Emission Unit Description: Transfer Rack

Emission unit ID number: L1001	Emission unit name: Loading Rack L1001	List any control devices associated with this emission unit: N/A
--	--	--

Provide a description of the emission unit (type, method of operation, design parameters, etc.):

Manufacturer:	Model number:	Serial number:
Construction date: See Attachment D Equipment Table	Installation date: See Attachment D Equipment Table	Modification date(s): See Attachment D Equipment Table

Design Capacity (examples: furnaces - tons/hr, tanks - gallons): See Attachment D Equipment Table

Maximum Hourly Throughput:	Maximum Annual Throughput:	Maximum Operating Schedule: 24 hrs/day, 365 days/yr
-----------------------------------	-----------------------------------	---

Fuel Usage Data (fill out all applicable fields)

Does this emission unit combust fuel? ___ Yes <u> X </u> No	If yes, is it? ___ Indirect Fired ___ Direct Fired
--	--

Maximum design heat input and/or maximum horsepower rating:	Type and Btu/hr rating of burners:
--	---

List the primary fuel type(s) and if applicable, the secondary fuel type(s). For each fuel type listed, provide the maximum hourly and annual fuel usage for each.

Describe each fuel expected to be used during the term of the permit.

Fuel Type	Max. Sulfur Content	Max. Ash Content	BTU Value

Union Carbide Corporation South Charleston Facility – TRITON

<i>Emissions Data</i>		
Criteria Pollutants	Potential Emissions	
	PPH	TPY
Carbon Monoxide (CO)		
Nitrogen Oxides (NO _x)		
Lead (Pb)		
Particulate Matter (PM _{2.5})		
Particulate Matter (PM ₁₀)		
Total Particulate Matter (TSP)		
Sulfur Dioxide (SO ₂)		
Volatile Organic Compounds (VOC)		
Hazardous Air Pollutants	Potential Emissions	
	PPH	TPY
Regulated Pollutants other than Criteria and HAP	Potential Emissions	
	PPH	TPY

List the method(s) used to calculate the potential emissions (include dates of any stack tests conducted, versions of software used, source and dates of emission factors, etc.).

Applicable Requirements

List all applicable requirements for this emission unit. For each applicable requirement, include the underlying rule/regulation citation and/or construction permit with the condition number. (Note: Title V permit condition numbers alone are not the underlying applicable requirements). If an emission limit is calculated based on the type of source and design capacity or if a standard is based on a design parameter, this information should also be included.

See Attachment I for applicable requirements, monitoring, recordkeeping, reporting and testing from existing Title V permit.

Permit Shield

For all applicable requirements listed above, provide monitoring/testing/recordkeeping/reporting which shall be used to demonstrate compliance. If the method is based on a permit or rule, include the condition number or citation. (Note: Each requirement listed above must have an associated method of demonstrating compliance. If there is not already a required method in place, then a method must be proposed.)

See Attachment I for applicable requirements, monitoring, recordkeeping, reporting and testing from existing Title V permit.

Are you in compliance with all applicable requirements for this emission unit? Yes No

If no, complete the **Schedule of Compliance Form** as ATTACHMENT F.

ATTACHMENT E - Emission Unit Form

Emission Unit Description: Transfer Rack

Emission unit ID number: L1003	Emission unit name: Loading Rack L1003	List any control devices associated with this emission unit: N/A
--	--	--

Provide a description of the emission unit (type, method of operation, design parameters, etc.):

Manufacturer:	Model number:	Serial number:
----------------------	----------------------	-----------------------

Construction date: See Attachment D Equipment Table	Installation date: See Attachment D Equipment Table	Modification date(s): See Attachment D Equipment Table
---	---	--

Design Capacity (examples: furnaces - tons/hr, tanks - gallons): See Attachment D Equipment Table

Maximum Hourly Throughput:	Maximum Annual Throughput:	Maximum Operating Schedule: 24 hrs/day, 365 days/yr
-----------------------------------	-----------------------------------	---

Fuel Usage Data (fill out all applicable fields)

Does this emission unit combust fuel? ___ Yes <u> X </u> No	If yes, is it? ___ Indirect Fired ___ Direct Fired
--	--

Maximum design heat input and/or maximum horsepower rating:	Type and Btu/hr rating of burners:
--	---

List the primary fuel type(s) and if applicable, the secondary fuel type(s). For each fuel type listed, provide the maximum hourly and annual fuel usage for each.

Describe each fuel expected to be used during the term of the permit.

Fuel Type	Max. Sulfur Content	Max. Ash Content	BTU Value

Union Carbide Corporation South Charleston Facility – TRITON

<i>Emissions Data</i>		
Criteria Pollutants	Potential Emissions	
	PPH	TPY
Carbon Monoxide (CO)		
Nitrogen Oxides (NO _x)		
Lead (Pb)		
Particulate Matter (PM _{2.5})		
Particulate Matter (PM ₁₀)		
Total Particulate Matter (TSP)		
Sulfur Dioxide (SO ₂)		
Volatile Organic Compounds (VOC)		
Hazardous Air Pollutants	Potential Emissions	
	PPH	TPY
Regulated Pollutants other than Criteria and HAP	Potential Emissions	
	PPH	TPY

List the method(s) used to calculate the potential emissions (include dates of any stack tests conducted, versions of software used, source and dates of emission factors, etc.).

Applicable Requirements

List all applicable requirements for this emission unit. For each applicable requirement, include the underlying rule/regulation citation and/or construction permit with the condition number. (Note: Title V permit condition numbers alone are not the underlying applicable requirements). If an emission limit is calculated based on the type of source and design capacity or if a standard is based on a design parameter, this information should also be included.

See Attachment I for applicable requirements, monitoring, recordkeeping, reporting and testing from existing Title V permit.

X Permit Shield

For all applicable requirements listed above, provide monitoring/testing/recordkeeping/reporting which shall be used to demonstrate compliance. If the method is based on a permit or rule, include the condition number or citation. (Note: Each requirement listed above must have an associated method of demonstrating compliance. If there is not already a required method in place, then a method must be proposed.)

See Attachment I for applicable requirements, monitoring, recordkeeping, reporting and testing from existing Title V permit.

Are you in compliance with all applicable requirements for this emission unit? X Yes No

If no, complete the **Schedule of Compliance Form** as **ATTACHMENT F**.

ATTACHMENT E - Emission Unit Form

Emission Unit Description: Transfer Rack

Emission unit ID number: L1002	Emission unit name: Loading Rack L1002	List any control devices associated with this emission unit: N/A
--	--	--

Provide a description of the emission unit (type, method of operation, design parameters, etc.):

Manufacturer:	Model number:	Serial number:
----------------------	----------------------	-----------------------

Construction date: See Attachment D Equipment Table	Installation date: See Attachment D Equipment Table	Modification date(s): See Attachment D Equipment Table
---	---	--

Design Capacity (examples: furnaces - tons/hr, tanks - gallons): See Attachment D Equipment Table

Maximum Hourly Throughput:	Maximum Annual Throughput:	Maximum Operating Schedule: 24 hrs/day, 365 days/yr
-----------------------------------	-----------------------------------	---

Fuel Usage Data (fill out all applicable fields)

Does this emission unit combust fuel? ___ Yes <u> X </u> No	If yes, is it? ___ Indirect Fired ___ Direct Fired
--	--

Maximum design heat input and/or maximum horsepower rating:	Type and Btu/hr rating of burners:
--	---

List the primary fuel type(s) and if applicable, the secondary fuel type(s). For each fuel type listed, provide the maximum hourly and annual fuel usage for each.

Describe each fuel expected to be used during the term of the permit.

Fuel Type	Max. Sulfur Content	Max. Ash Content	BTU Value

Union Carbide Corporation South Charleston Facility – TRITON

<i>Emissions Data</i>		
Criteria Pollutants	Potential Emissions	
	PPH	TPY
Carbon Monoxide (CO)		
Nitrogen Oxides (NO _x)		
Lead (Pb)		
Particulate Matter (PM _{2.5})		
Particulate Matter (PM ₁₀)		
Total Particulate Matter (TSP)		
Sulfur Dioxide (SO ₂)		
Volatile Organic Compounds (VOC)		
Hazardous Air Pollutants	Potential Emissions	
	PPH	TPY
Regulated Pollutants other than Criteria and HAP	Potential Emissions	
	PPH	TPY

List the method(s) used to calculate the potential emissions (include dates of any stack tests conducted, versions of software used, source and dates of emission factors, etc.).

Applicable Requirements

List all applicable requirements for this emission unit. For each applicable requirement, include the underlying rule/regulation citation and/or construction permit with the condition number. (Note: Title V permit condition numbers alone are not the underlying applicable requirements). If an emission limit is calculated based on the type of source and design capacity or if a standard is based on a design parameter, this information should also be included.

See Attachment I for applicable requirements, monitoring, recordkeeping, reporting and testing from existing Title V permit.

 X Permit Shield

For all applicable requirements listed above, provide monitoring/testing/recordkeeping/reporting which shall be used to demonstrate compliance. If the method is based on a permit or rule, include the condition number or citation. (Note: Each requirement listed above must have an associated method of demonstrating compliance. If there is not already a required method in place, then a method must be proposed.)

See Attachment I for applicable requirements, monitoring, recordkeeping, reporting and testing from existing Title V permit.

Are you in compliance with all applicable requirements for this emission unit? X Yes No

If no, complete the **Schedule of Compliance Form** as **ATTACHMENT F**.

ATTACHMENT E - Emission Unit Form

Emission Unit Description: Condenser

Emission unit ID number: E8105	Emission unit name: Condenser	List any control devices associated with this emission unit:	
Provide a description of the emission unit (type, method of operation, design parameters, etc.): Storage of volatile organic compounds			
Manufacturer:	Model number:	Serial number:	
Construction date: See Attachment D Equipment Table	Installation date: See Attachment D Equipment Table	Modification date(s): See Attachment D Equipment Table	
Design Capacity (examples: furnaces - tons/hr, tanks - gallons): See Attachment D Equipment Table			
Maximum Hourly Throughput:	Maximum Annual Throughput:	Maximum Operating Schedule: 24 hrs/day, 365 days/yr	
Fuel Usage Data (fill out all applicable fields)			
Does this emission unit combust fuel? ___ Yes <input checked="" type="checkbox"/> No		If yes, is it? ___ Indirect Fired ___ Direct Fired	
Maximum design heat input and/or maximum horsepower rating:		Type and Btu/hr rating of burners:	
List the primary fuel type(s) and if applicable, the secondary fuel type(s). For each fuel type listed, provide the maximum hourly and annual fuel usage for each.			
Describe each fuel expected to be used during the term of the permit.			
Fuel Type	Max. Sulfur Content	Max. Ash Content	BTU Value

Union Carbide Corporation South Charleston Facility – TRITON

<i>Emissions Data</i>		
Criteria Pollutants	Potential Emissions	
	PPH	TPY
Carbon Monoxide (CO)		
Nitrogen Oxides (NO _x)		
Lead (Pb)		
Particulate Matter (PM _{2.5})		
Particulate Matter (PM ₁₀)		
Total Particulate Matter (TSP)		
Sulfur Dioxide (SO ₂)		
Volatile Organic Compounds (VOC)		
Hazardous Air Pollutants	Potential Emissions	
	PPH	TPY
Regulated Pollutants other than Criteria and HAP	Potential Emissions	
	PPH	TPY

List the method(s) used to calculate the potential emissions (include dates of any stack tests conducted, versions of software used, source and dates of emission factors, etc.).

Applicable Requirements

List all applicable requirements for this emission unit. For each applicable requirement, include the underlying rule/regulation citation and/or construction permit with the condition number. (Note: Title V permit condition numbers alone are not the underlying applicable requirements). If an emission limit is calculated based on the type of source and design capacity or if a standard is based on a design parameter, this information should also be included.

See Attachment I for applicable requirements, monitoring, recordkeeping, reporting and testing from existing Title V permit.

X Permit Shield

For all applicable requirements listed above, provide monitoring/testing/recordkeeping/reporting which shall be used to demonstrate compliance. If the method is based on a permit or rule, include the condition number or citation. (Note: Each requirement listed above must have an associated method of demonstrating compliance. If there is not already a required method in place, then a method must be proposed.)

See Attachment I for applicable requirements, monitoring, recordkeeping, reporting and testing from existing Title V permit.

Are you in compliance with all applicable requirements for this emission unit? X Yes No

If no, complete the **Schedule of Compliance Form** as **ATTACHMENT F**.

ATTACHMENT E - Emission Unit Form

Emission Unit Description: Filter Press

Emission unit ID number: 8820	Emission unit name: West Filter Press	List any control devices associated with this emission unit: N/A
---	---	--

Provide a description of the emission unit (type, method of operation, design parameters, etc.):

Manufacturer:	Model number:	Serial number:
----------------------	----------------------	-----------------------

Construction date: See Attachment D Equipment Table	Installation date: See Attachment D Equipment Table	Modification date(s): See Attachment D Equipment Table
---	---	--

Design Capacity (examples: furnaces - tons/hr, tanks - gallons): See Attachment D Equipment Table

Maximum Hourly Throughput:	Maximum Annual Throughput:	Maximum Operating Schedule: 24 hrs/day, 365 days/yr
-----------------------------------	-----------------------------------	---

Fuel Usage Data (fill out all applicable fields)

Does this emission unit combust fuel? ___ Yes <input checked="" type="checkbox"/> No	If yes, is it? ___ Indirect Fired ___ Direct Fired
---	--

Maximum design heat input and/or maximum horsepower rating:	Type and Btu/hr rating of burners:
--	---

List the primary fuel type(s) and if applicable, the secondary fuel type(s). For each fuel type listed, provide the maximum hourly and annual fuel usage for each.

Describe each fuel expected to be used during the term of the permit.

Fuel Type	Max. Sulfur Content	Max. Ash Content	BTU Value

Union Carbide Corporation South Charleston Facility – TRITON

<i>Emissions Data</i>		
Criteria Pollutants	Potential Emissions	
	PPH	TPY
Carbon Monoxide (CO)		
Nitrogen Oxides (NO _x)		
Lead (Pb)		
Particulate Matter (PM _{2.5})		
Particulate Matter (PM ₁₀)		
Total Particulate Matter (TSP)		
Sulfur Dioxide (SO ₂)		
Volatile Organic Compounds (VOC)		
Hazardous Air Pollutants	Potential Emissions	
	PPH	TPY
Regulated Pollutants other than Criteria and HAP	Potential Emissions	
	PPH	TPY

List the method(s) used to calculate the potential emissions (include dates of any stack tests conducted, versions of software used, source and dates of emission factors, etc.).

Applicable Requirements

List all applicable requirements for this emission unit. For each applicable requirement, include the underlying rule/regulation citation and/or construction permit with the condition number. (Note: Title V permit condition numbers alone are not the underlying applicable requirements). If an emission limit is calculated based on the type of source and design capacity or if a standard is based on a design parameter, this information should also be included.

See Attachment I for applicable requirements, monitoring, recordkeeping, reporting and testing from existing Title V permit.

X Permit Shield

For all applicable requirements listed above, provide monitoring/testing/recordkeeping/reporting which shall be used to demonstrate compliance. If the method is based on a permit or rule, include the condition number or citation. (Note: Each requirement listed above must have an associated method of demonstrating compliance. If there is not already a required method in place, then a method must be proposed.)

See Attachment I for applicable requirements, monitoring, recordkeeping, reporting and testing from existing Title V permit.

Are you in compliance with all applicable requirements for this emission unit? X Yes No

If no, complete the **Schedule of Compliance Form** as **ATTACHMENT F**.

ATTACHMENT E - Emission Unit Form

Emission Unit Description: Storage Tank			
Emission unit ID number: 8835	Emission unit name: Tank 8835	List any control devices associated with this emission unit: N/A	
Provide a description of the emission unit (type, method of operation, design parameters, etc.): Storage of volatile organic compounds			
Manufacturer:	Model number:	Serial number:	
Construction date: See Attachment D Equipment Table	Installation date: See Attachment D Equipment Table	Modification date(s): See Attachment D Equipment Table	
Design Capacity (examples: furnaces - tons/hr, tanks - gallons): See Attachment D Equipment Table			
Maximum Hourly Throughput:	Maximum Annual Throughput:	Maximum Operating Schedule: 24 hrs/day, 365 days/yr	
Fuel Usage Data (fill out all applicable fields)			
Does this emission unit combust fuel? ___ Yes <input checked="" type="checkbox"/> No		If yes, is it? ___ Indirect Fired ___ Direct Fired	
Maximum design heat input and/or maximum horsepower rating:		Type and Btu/hr rating of burners:	
List the primary fuel type(s) and if applicable, the secondary fuel type(s). For each fuel type listed, provide the maximum hourly and annual fuel usage for each.			
Describe each fuel expected to be used during the term of the permit.			
Fuel Type	Max. Sulfur Content	Max. Ash Content	BTU Value

Union Carbide Corporation South Charleston Facility – TRITON

Emissions Data		
Criteria Pollutants	Potential Emissions	
	PPH	TPY
Carbon Monoxide (CO)		
Nitrogen Oxides (NO _x)		
Lead (Pb)		
Particulate Matter (PM _{2.5})		
Particulate Matter (PM ₁₀)		
Total Particulate Matter (TSP)		
Sulfur Dioxide (SO ₂)		
Volatile Organic Compounds (VOC)		
Hazardous Air Pollutants	Potential Emissions	
	PPH	TPY
Regulated Pollutants other than Criteria and HAP	Potential Emissions	
	PPH	TPY

List the method(s) used to calculate the potential emissions (include dates of any stack tests conducted, versions of software used, source and dates of emission factors, etc.).

Applicable Requirements

List all applicable requirements for this emission unit. For each applicable requirement, include the underlying rule/regulation citation and/or construction permit with the condition number. (Note: Title V permit condition numbers alone are not the underlying applicable requirements). If an emission limit is calculated based on the type of source and design capacity or if a standard is based on a design parameter, this information should also be included.

See Attachment I for applicable requirements, monitoring, recordkeeping, reporting and testing from existing Title V permit.

Permit Shield

For all applicable requirements listed above, provide monitoring/testing/recordkeeping/reporting which shall be used to demonstrate compliance. If the method is based on a permit or rule, include the condition number or citation. (Note: Each requirement listed above must have an associated method of demonstrating compliance. If there is not already a required method in place, then a method must be proposed.)

See Attachment I for applicable requirements, monitoring, recordkeeping, reporting and testing from existing Title V permit.

Are you in compliance with all applicable requirements for this emission unit? Yes No

If no, complete the **Schedule of Compliance Form** as ATTACHMENT F.

ATTACHMENT E - Emission Unit Form

Emission Unit Description: Storage Tank

Emission unit ID number: 8817	Emission unit name: Tank 8817	List any control devices associated with this emission unit: N/A
---	---	--

Provide a description of the emission unit (type, method of operation, design parameters, etc.):

Storage of volatile organic compounds

Manufacturer:	Model number:	Serial number:
----------------------	----------------------	-----------------------

Construction date: See Attachment D Equipment Table	Installation date: See Attachment D Equipment Table	Modification date(s): See Attachment D Equipment Table
---	---	--

Design Capacity (examples: furnaces - tons/hr, tanks - gallons): See Attachment D Equipment Table

Maximum Hourly Throughput:	Maximum Annual Throughput:	Maximum Operating Schedule: 24 hrs/day, 365 days/yr
-----------------------------------	-----------------------------------	---

Fuel Usage Data (fill out all applicable fields)

Does this emission unit combust fuel? ___ Yes <u> X </u> No	If yes, is it? ___ Indirect Fired ___ Direct Fired
--	--

Maximum design heat input and/or maximum horsepower rating:	Type and Btu/hr rating of burners:
--	---

List the primary fuel type(s) and if applicable, the secondary fuel type(s). For each fuel type listed, provide the maximum hourly and annual fuel usage for each.

Describe each fuel expected to be used during the term of the permit.

Fuel Type	Max. Sulfur Content	Max. Ash Content	BTU Value

Union Carbide Corporation South Charleston Facility – TRITON

<i>Emissions Data</i>		
Criteria Pollutants	Potential Emissions	
	PPH	TPY
Carbon Monoxide (CO)		
Nitrogen Oxides (NO _x)		
Lead (Pb)		
Particulate Matter (PM _{2.5})		
Particulate Matter (PM ₁₀)		
Total Particulate Matter (TSP)		
Sulfur Dioxide (SO ₂)		
Volatile Organic Compounds (VOC)		
Hazardous Air Pollutants	Potential Emissions	
	PPH	TPY
Regulated Pollutants other than Criteria and HAP	Potential Emissions	
	PPH	TPY

List the method(s) used to calculate the potential emissions (include dates of any stack tests conducted, versions of software used, source and dates of emission factors, etc.).

Applicable Requirements

List all applicable requirements for this emission unit. For each applicable requirement, include the underlying rule/regulation citation and/or construction permit with the condition number. (Note: Title V permit condition numbers alone are not the underlying applicable requirements). If an emission limit is calculated based on the type of source and design capacity or if a standard is based on a design parameter, this information should also be included.

See Attachment I for applicable requirements, monitoring, recordkeeping, reporting and testing from existing Title V permit.

X Permit Shield

For all applicable requirements listed above, provide monitoring/testing/recordkeeping/reporting which shall be used to demonstrate compliance. If the method is based on a permit or rule, include the condition number or citation. (Note: Each requirement listed above must have an associated method of demonstrating compliance. If there is not already a required method in place, then a method must be proposed.)

See Attachment I for applicable requirements, monitoring, recordkeeping, reporting and testing from existing Title V permit.

Are you in compliance with all applicable requirements for this emission unit? X Yes No

If no, complete the **Schedule of Compliance Form** as **ATTACHMENT F**.

ATTACHMENT E - Emission Unit Form

Emission Unit Description: Storage Tank

Emission unit ID number: 8738	Emission unit name: Tank 8738	List any control devices associated with this emission unit:
---	---	---

Provide a description of the emission unit (type, method of operation, design parameters, etc.):

Storage of volatile organic compounds

Manufacturer:	Model number:	Serial number:
----------------------	----------------------	-----------------------

Construction date: See Attachment D Equipment Table	Installation date: See Attachment D Equipment Table	Modification date(s): See Attachment D Equipment Table
---	---	--

Design Capacity (examples: furnaces - tons/hr, tanks - gallons): See Attachment D Equipment Table

Maximum Hourly Throughput:	Maximum Annual Throughput:	Maximum Operating Schedule: 24 hrs/day, 365 days/yr
-----------------------------------	-----------------------------------	---

Fuel Usage Data (fill out all applicable fields)

Does this emission unit combust fuel? ___ Yes <u> X </u> No	If yes, is it? ___ Indirect Fired ___ Direct Fired
--	--

Maximum design heat input and/or maximum horsepower rating:	Type and Btu/hr rating of burners:
--	---

List the primary fuel type(s) and if applicable, the secondary fuel type(s). For each fuel type listed, provide the maximum hourly and annual fuel usage for each.

Describe each fuel expected to be used during the term of the permit.

Fuel Type	Max. Sulfur Content	Max. Ash Content	BTU Value

Union Carbide Corporation South Charleston Facility – TRITON

<i>Emissions Data</i>		
Criteria Pollutants	Potential Emissions	
	PPH	TPY
Carbon Monoxide (CO)		
Nitrogen Oxides (NO _x)		
Lead (Pb)		
Particulate Matter (PM _{2.5})		
Particulate Matter (PM ₁₀)		
Total Particulate Matter (TSP)		
Sulfur Dioxide (SO ₂)		
Volatile Organic Compounds (VOC)		
Hazardous Air Pollutants	Potential Emissions	
	PPH	TPY
Regulated Pollutants other than Criteria and HAP	Potential Emissions	
	PPH	TPY

List the method(s) used to calculate the potential emissions (include dates of any stack tests conducted, versions of software used, source and dates of emission factors, etc.).

Applicable Requirements

List all applicable requirements for this emission unit. For each applicable requirement, include the underlying rule/regulation citation and/or construction permit with the condition number. (Note: Title V permit condition numbers alone are not the underlying applicable requirements). If an emission limit is calculated based on the type of source and design capacity or if a standard is based on a design parameter, this information should also be included.

See Attachment I for applicable requirements, monitoring, recordkeeping, reporting and testing from existing Title V permit.

X Permit Shield

For all applicable requirements listed above, provide monitoring/testing/recordkeeping/reporting which shall be used to demonstrate compliance. If the method is based on a permit or rule, include the condition number or citation. (Note: Each requirement listed above must have an associated method of demonstrating compliance. If there is not already a required method in place, then a method must be proposed.)

See Attachment I for applicable requirements, monitoring, recordkeeping, reporting and testing from existing Title V permit.

Are you in compliance with all applicable requirements for this emission unit? X Yes No

If no, complete the **Schedule of Compliance Form** as **ATTACHMENT F**.

ATTACHMENT E - Emission Unit Form

Emission Unit Description: Storage Tank			
Emission unit ID number: 8723	Emission unit name: Tank 8723	List any control devices associated with this emission unit: N/A	
Provide a description of the emission unit (type, method of operation, design parameters, etc.): Storage of volatile organic compounds			
Manufacturer:	Model number:	Serial number:	
Construction date: See Attachment D Equipment Table	Installation date: See Attachment D Equipment Table	Modification date(s): See Attachment D Equipment Table	
Design Capacity (examples: furnaces - tons/hr, tanks - gallons): See Attachment D Equipment Table			
Maximum Hourly Throughput:	Maximum Annual Throughput:	Maximum Operating Schedule: 24 hrs/day, 365 days/yr	
Fuel Usage Data (fill out all applicable fields)			
Does this emission unit combust fuel? ___Yes <input checked="" type="checkbox"/> No		If yes, is it? ___ Indirect Fired ___Direct Fired	
Maximum design heat input and/or maximum horsepower rating:		Type and Btu/hr rating of burners:	
List the primary fuel type(s) and if applicable, the secondary fuel type(s). For each fuel type listed, provide the maximum hourly and annual fuel usage for each.			
Describe each fuel expected to be used during the term of the permit.			
Fuel Type	Max. Sulfur Content	Max. Ash Content	BTU Value

Union Carbide Corporation South Charleston Facility – TRITON

<i>Emissions Data</i>		
Criteria Pollutants	Potential Emissions	
	PPH	TPY
Carbon Monoxide (CO)		
Nitrogen Oxides (NO _x)		
Lead (Pb)		
Particulate Matter (PM _{2.5})		
Particulate Matter (PM ₁₀)		
Total Particulate Matter (TSP)		
Sulfur Dioxide (SO ₂)		
Volatile Organic Compounds (VOC)		
Hazardous Air Pollutants	Potential Emissions	
	PPH	TPY
Regulated Pollutants other than Criteria and HAP	Potential Emissions	
	PPH	TPY

List the method(s) used to calculate the potential emissions (include dates of any stack tests conducted, versions of software used, source and dates of emission factors, etc.).

Applicable Requirements

List all applicable requirements for this emission unit. For each applicable requirement, include the underlying rule/regulation citation and/or construction permit with the condition number. (Note: Title V permit condition numbers alone are not the underlying applicable requirements). If an emission limit is calculated based on the type of source and design capacity or if a standard is based on a design parameter, this information should also be included.

See Attachment I for applicable requirements, monitoring, recordkeeping, reporting and testing from existing Title V permit.

 X Permit Shield

For all applicable requirements listed above, provide monitoring/testing/recordkeeping/reporting which shall be used to demonstrate compliance. If the method is based on a permit or rule, include the condition number or citation. (Note: Each requirement listed above must have an associated method of demonstrating compliance. If there is not already a required method in place, then a method must be proposed.)

See Attachment I for applicable requirements, monitoring, recordkeeping, reporting and testing from existing Title V permit.

Are you in compliance with all applicable requirements for this emission unit? X Yes No

If no, complete the **Schedule of Compliance Form** as **ATTACHMENT F**.

ATTACHMENT E - Emission Unit Form

Emission Unit Description: Storage Tank

Emission unit ID number: 8721	Emission unit name: Tank 8721	List any control devices associated with this emission unit: N/A
---	---	--

Provide a description of the emission unit (type, method of operation, design parameters, etc.):
Storage of volatile organic compounds

Manufacturer:	Model number:	Serial number:
----------------------	----------------------	-----------------------

Construction date: See Attachment D Equipment Table	Installation date: See Attachment D Equipment Table	Modification date(s): See Attachment D Equipment Table
---	---	--

Design Capacity (examples: furnaces - tons/hr, tanks - gallons): See Attachment D Equipment Table

Maximum Hourly Throughput:	Maximum Annual Throughput:	Maximum Operating Schedule: 24 hrs/day, 365 days/yr
-----------------------------------	-----------------------------------	---

Fuel Usage Data (fill out all applicable fields)

Does this emission unit combust fuel? ___Yes <u>X</u> No	If yes, is it? ___ Indirect Fired ___Direct Fired
---	---

Maximum design heat input and/or maximum horsepower rating:	Type and Btu/hr rating of burners:
--	---

List the primary fuel type(s) and if applicable, the secondary fuel type(s). For each fuel type listed, provide the maximum hourly and annual fuel usage for each.

Describe each fuel expected to be used during the term of the permit.

Fuel Type	Max. Sulfur Content	Max. Ash Content	BTU Value

Union Carbide Corporation South Charleston Facility – TRITON

<i>Emissions Data</i>		
Criteria Pollutants	Potential Emissions	
	PPH	TPY
Carbon Monoxide (CO)		
Nitrogen Oxides (NO _x)		
Lead (Pb)		
Particulate Matter (PM _{2.5})		
Particulate Matter (PM ₁₀)		
Total Particulate Matter (TSP)		
Sulfur Dioxide (SO ₂)		
Volatile Organic Compounds (VOC)		
Hazardous Air Pollutants	Potential Emissions	
	PPH	TPY
Regulated Pollutants other than Criteria and HAP	Potential Emissions	
	PPH	TPY

List the method(s) used to calculate the potential emissions (include dates of any stack tests conducted, versions of software used, source and dates of emission factors, etc.).

Applicable Requirements

List all applicable requirements for this emission unit. For each applicable requirement, include the underlying rule/regulation citation and/or construction permit with the condition number. (Note: Title V permit condition numbers alone are not the underlying applicable requirements). If an emission limit is calculated based on the type of source and design capacity or if a standard is based on a design parameter, this information should also be included.

See Attachment I for applicable requirements, monitoring, recordkeeping, reporting and testing from existing Title V permit.

Permit Shield

For all applicable requirements listed above, provide monitoring/testing/recordkeeping/reporting which shall be used to demonstrate compliance. If the method is based on a permit or rule, include the condition number or citation. (Note: Each requirement listed above must have an associated method of demonstrating compliance. If there is not already a required method in place, then a method must be proposed.)

See Attachment I for applicable requirements, monitoring, recordkeeping, reporting and testing from existing Title V permit.

Are you in compliance with all applicable requirements for this emission unit? Yes No

If no, complete the **Schedule of Compliance Form** as ATTACHMENT F.

ATTACHMENT E - Emission Unit Form

Emission Unit Description: Storage Tank

Emission unit ID number: 8729	Emission unit name: Tank 8729	List any control devices associated with this emission unit: N/A
---	---	--

Provide a description of the emission unit (type, method of operation, design parameters, etc.):

No regulated pollutant

Manufacturer:	Model number:	Serial number:
----------------------	----------------------	-----------------------

Construction date: See Attachment D Equipment Table	Installation date: See Attachment D Equipment Table	Modification date(s): See Attachment D Equipment Table
---	---	--

Design Capacity (examples: furnaces - tons/hr, tanks - gallons): See Attachment D Equipment Table

Maximum Hourly Throughput:	Maximum Annual Throughput:	Maximum Operating Schedule: 24 hrs/day, 365 days/yr
-----------------------------------	-----------------------------------	---

Fuel Usage Data (fill out all applicable fields)

Does this emission unit combust fuel? ___Yes <u>X</u> No	If yes, is it? ___ Indirect Fired ___Direct Fired
---	---

Maximum design heat input and/or maximum horsepower rating:	Type and Btu/hr rating of burners:
--	---

List the primary fuel type(s) and if applicable, the secondary fuel type(s). For each fuel type listed, provide the maximum hourly and annual fuel usage for each.

Describe each fuel expected to be used during the term of the permit.

Fuel Type	Max. Sulfur Content	Max. Ash Content	BTU Value

Union Carbide Corporation South Charleston Facility – TRITON

<i>Emissions Data</i>		
Criteria Pollutants	Potential Emissions	
	PPH	TPY
Carbon Monoxide (CO)		
Nitrogen Oxides (NO _x)		
Lead (Pb)		
Particulate Matter (PM _{2.5})		
Particulate Matter (PM ₁₀)		
Total Particulate Matter (TSP)		
Sulfur Dioxide (SO ₂)		
Volatile Organic Compounds (VOC)		
Hazardous Air Pollutants	Potential Emissions	
	PPH	TPY
Regulated Pollutants other than Criteria and HAP	Potential Emissions	
	PPH	TPY

List the method(s) used to calculate the potential emissions (include dates of any stack tests conducted, versions of software used, source and dates of emission factors, etc.).

Applicable Requirements

List all applicable requirements for this emission unit. For each applicable requirement, include the underlying rule/regulation citation and/or construction permit with the condition number. (Note: Title V permit condition numbers alone are not the underlying applicable requirements). If an emission limit is calculated based on the type of source and design capacity or if a standard is based on a design parameter, this information should also be included.

See Attachment I for applicable requirements, monitoring, recordkeeping, reporting and testing from existing Title V permit.

X Permit Shield

For all applicable requirements listed above, provide monitoring/testing/recordkeeping/reporting which shall be used to demonstrate compliance. If the method is based on a permit or rule, include the condition number or citation. (Note: Each requirement listed above must have an associated method of demonstrating compliance. If there is not already a required method in place, then a method must be proposed.)

See Attachment I for applicable requirements, monitoring, recordkeeping, reporting and testing from existing Title V permit.

Are you in compliance with all applicable requirements for this emission unit? X Yes No

If no, complete the **Schedule of Compliance Form** as **ATTACHMENT F**.

ATTACHMENT E - Emission Unit Form

Emission Unit Description: Storage Tank			
Emission unit ID number: 8725	Emission unit name: Tank 8725	List any control devices associated with this emission unit: N/A	
Provide a description of the emission unit (type, method of operation, design parameters, etc.): Storage of volatile organic compounds			
Manufacturer:	Model number:	Serial number:	
Construction date: See Attachment D Equipment Table	Installation date: See Attachment D Equipment Table	Modification date(s): See Attachment D Equipment Table	
Design Capacity (examples: furnaces - tons/hr, tanks - gallons): See Attachment D Equipment Table			
Maximum Hourly Throughput:	Maximum Annual Throughput:	Maximum Operating Schedule: 24 hrs/day, 365 days/yr	
Fuel Usage Data (fill out all applicable fields)			
Does this emission unit combust fuel? ___Yes <input checked="" type="checkbox"/> No		If yes, is it? ___ Indirect Fired ___Direct Fired	
Maximum design heat input and/or maximum horsepower rating:		Type and Btu/hr rating of burners:	
List the primary fuel type(s) and if applicable, the secondary fuel type(s). For each fuel type listed, provide the maximum hourly and annual fuel usage for each.			
Describe each fuel expected to be used during the term of the permit.			
Fuel Type	Max. Sulfur Content	Max. Ash Content	BTU Value

Union Carbide Corporation South Charleston Facility – TRITON

<i>Emissions Data</i>		
Criteria Pollutants	Potential Emissions	
	PPH	TPY
Carbon Monoxide (CO)		
Nitrogen Oxides (NO _x)		
Lead (Pb)		
Particulate Matter (PM _{2.5})		
Particulate Matter (PM ₁₀)		
Total Particulate Matter (TSP)		
Sulfur Dioxide (SO ₂)		
Volatile Organic Compounds (VOC)		
Hazardous Air Pollutants	Potential Emissions	
	PPH	TPY
Regulated Pollutants other than Criteria and HAP	Potential Emissions	
	PPH	TPY

List the method(s) used to calculate the potential emissions (include dates of any stack tests conducted, versions of software used, source and dates of emission factors, etc.).

Applicable Requirements

List all applicable requirements for this emission unit. For each applicable requirement, include the underlying rule/regulation citation and/or construction permit with the condition number. (Note: Title V permit condition numbers alone are not the underlying applicable requirements). If an emission limit is calculated based on the type of source and design capacity or if a standard is based on a design parameter, this information should also be included.

See Attachment I for applicable requirements, monitoring, recordkeeping, reporting and testing from existing Title V permit.

X Permit Shield

For all applicable requirements listed above, provide monitoring/testing/recordkeeping/reporting which shall be used to demonstrate compliance. If the method is based on a permit or rule, include the condition number or citation. (Note: Each requirement listed above must have an associated method of demonstrating compliance. If there is not already a required method in place, then a method must be proposed.)

See Attachment I for applicable requirements, monitoring, recordkeeping, reporting and testing from existing Title V permit.

Are you in compliance with all applicable requirements for this emission unit? X Yes No

If no, complete the **Schedule of Compliance Form** as ATTACHMENT F.

ATTACHMENT E - Emission Unit Form

Emission Unit Description: Storage Tank

Emission unit ID number: 8706	Emission unit name: Tank 8706	List any control devices associated with this emission unit: N/A
---	---	--

Provide a description of the emission unit (type, method of operation, design parameters, etc.):
Storage of volatile organic compounds

Manufacturer:	Model number:	Serial number:
----------------------	----------------------	-----------------------

Construction date: See Attachment D Equipment Table	Installation date: See Attachment D Equipment Table	Modification date(s): See Attachment D Equipment Table
---	---	--

Design Capacity (examples: furnaces - tons/hr, tanks - gallons): See Attachment D Equipment Table

Maximum Hourly Throughput:	Maximum Annual Throughput:	Maximum Operating Schedule: 24 hrs/day, 365 days/yr
-----------------------------------	-----------------------------------	---

Fuel Usage Data (fill out all applicable fields)

Does this emission unit combust fuel? ___Yes <u>X</u> No	If yes, is it? ___ Indirect Fired ___Direct Fired
---	---

Maximum design heat input and/or maximum horsepower rating:	Type and Btu/hr rating of burners:
--	---

List the primary fuel type(s) and if applicable, the secondary fuel type(s). For each fuel type listed, provide the maximum hourly and annual fuel usage for each.

Describe each fuel expected to be used during the term of the permit.

Fuel Type	Max. Sulfur Content	Max. Ash Content	BTU Value

Union Carbide Corporation South Charleston Facility – TRITON

<i>Emissions Data</i>		
Criteria Pollutants	Potential Emissions	
	PPH	TPY
Carbon Monoxide (CO)		
Nitrogen Oxides (NO _x)		
Lead (Pb)		
Particulate Matter (PM _{2.5})		
Particulate Matter (PM ₁₀)		
Total Particulate Matter (TSP)		
Sulfur Dioxide (SO ₂)		
Volatile Organic Compounds (VOC)		
Hazardous Air Pollutants	Potential Emissions	
	PPH	TPY
Regulated Pollutants other than Criteria and HAP	Potential Emissions	
	PPH	TPY

List the method(s) used to calculate the potential emissions (include dates of any stack tests conducted, versions of software used, source and dates of emission factors, etc.).

Applicable Requirements

List all applicable requirements for this emission unit. For each applicable requirement, include the underlying rule/regulation citation and/or construction permit with the condition number. (Note: Title V permit condition numbers alone are not the underlying applicable requirements). If an emission limit is calculated based on the type of source and design capacity or if a standard is based on a design parameter, this information should also be included.

See Attachment I for applicable requirements, monitoring, recordkeeping, reporting and testing from existing Title V permit.

X Permit Shield

For all applicable requirements listed above, provide monitoring/testing/recordkeeping/reporting which shall be used to demonstrate compliance. If the method is based on a permit or rule, include the condition number or citation. (Note: Each requirement listed above must have an associated method of demonstrating compliance. If there is not already a required method in place, then a method must be proposed.)

See Attachment I for applicable requirements, monitoring, recordkeeping, reporting and testing from existing Title V permit.

Are you in compliance with all applicable requirements for this emission unit? X Yes No

If no, complete the **Schedule of Compliance Form** as **ATTACHMENT F**.

ATTACHMENT E - Emission Unit Form

Emission Unit Description: Storage Tank

Emission unit ID number: 8709	Emission unit name: Tank 8709	List any control devices associated with this emission unit: N/A
---	---	--

Provide a description of the emission unit (type, method of operation, design parameters, etc.):

Storage of volatile organic compounds

Manufacturer:	Model number:	Serial number:
----------------------	----------------------	-----------------------

Construction date: See Attachment D Equipment Table	Installation date: See Attachment D Equipment Table	Modification date(s): See Attachment D Equipment Table
---	---	--

Design Capacity (examples: furnaces - tons/hr, tanks - gallons): See Attachment D Equipment Table

Maximum Hourly Throughput:	Maximum Annual Throughput:	Maximum Operating Schedule: 24 hrs/day, 365 days/yr
-----------------------------------	-----------------------------------	---

Fuel Usage Data (fill out all applicable fields)

Does this emission unit combust fuel? ___Yes <u>X</u> No	If yes, is it? ___ Indirect Fired ___Direct Fired
---	---

Maximum design heat input and/or maximum horsepower rating:	Type and Btu/hr rating of burners:
--	---

List the primary fuel type(s) and if applicable, the secondary fuel type(s). For each fuel type listed, provide the maximum hourly and annual fuel usage for each.

Describe each fuel expected to be used during the term of the permit.

Fuel Type	Max. Sulfur Content	Max. Ash Content	BTU Value

Union Carbide Corporation South Charleston Facility – TRITON

<i>Emissions Data</i>		
Criteria Pollutants	Potential Emissions	
	PPH	TPY
Carbon Monoxide (CO)		
Nitrogen Oxides (NO _x)		
Lead (Pb)		
Particulate Matter (PM _{2.5})		
Particulate Matter (PM ₁₀)		
Total Particulate Matter (TSP)		
Sulfur Dioxide (SO ₂)		
Volatile Organic Compounds (VOC)		
Hazardous Air Pollutants	Potential Emissions	
	PPH	TPY
Regulated Pollutants other than Criteria and HAP	Potential Emissions	
	PPH	TPY

List the method(s) used to calculate the potential emissions (include dates of any stack tests conducted, versions of software used, source and dates of emission factors, etc.).

Applicable Requirements

List all applicable requirements for this emission unit. For each applicable requirement, include the underlying rule/regulation citation and/or construction permit with the condition number. (Note: Title V permit condition numbers alone are not the underlying applicable requirements). If an emission limit is calculated based on the type of source and design capacity or if a standard is based on a design parameter, this information should also be included.

See Attachment I for applicable requirements, monitoring, recordkeeping, reporting and testing from existing Title V permit.

 X Permit Shield

For all applicable requirements listed above, provide monitoring/testing/recordkeeping/reporting which shall be used to demonstrate compliance. If the method is based on a permit or rule, include the condition number or citation. (Note: Each requirement listed above must have an associated method of demonstrating compliance. If there is not already a required method in place, then a method must be proposed.)

See Attachment I for applicable requirements, monitoring, recordkeeping, reporting and testing from existing Title V permit.

Are you in compliance with all applicable requirements for this emission unit? X Yes No

If no, complete the **Schedule of Compliance Form** as **ATTACHMENT F**.

ATTACHMENT E - Emission Unit Form

Emission Unit Description: Reactor

Emission unit ID number: 8617	Emission unit name: 8617 Reactor	List any control devices associated with this emission unit: C8130 or none
---	--	--

Provide a description of the emission unit (type, method of operation, design parameters, etc.):

Manufacturer:	Model number:	Serial number:
----------------------	----------------------	-----------------------

Construction date: See Attachment D Equipment Table	Installation date: See Attachment D Equipment Table	Modification date(s): See Attachment D Equipment Table
---	---	--

Design Capacity (examples: furnaces - tons/hr, tanks - gallons): See Attachment D Equipment Table

Maximum Hourly Throughput:	Maximum Annual Throughput:	Maximum Operating Schedule: 24 hrs/day, 365 days/yr
-----------------------------------	-----------------------------------	---

Fuel Usage Data (fill out all applicable fields)

Does this emission unit combust fuel? ___ Yes <u> X </u> No	If yes, is it? ___ Indirect Fired ___ Direct Fired
--	--

Maximum design heat input and/or maximum horsepower rating:	Type and Btu/hr rating of burners:
--	---

List the primary fuel type(s) and if applicable, the secondary fuel type(s). For each fuel type listed, provide the maximum hourly and annual fuel usage for each.

Describe each fuel expected to be used during the term of the permit.

Fuel Type	Max. Sulfur Content	Max. Ash Content	BTU Value

Union Carbide Corporation South Charleston Facility – TRITON

<i>Emissions Data</i>		
Criteria Pollutants	Potential Emissions	
	PPH	TPY
Carbon Monoxide (CO)		
Nitrogen Oxides (NO _x)		
Lead (Pb)		
Particulate Matter (PM _{2.5})		
Particulate Matter (PM ₁₀)		
Total Particulate Matter (TSP)		
Sulfur Dioxide (SO ₂)		
Volatile Organic Compounds (VOC)		
Hazardous Air Pollutants	Potential Emissions	
	PPH	TPY
Regulated Pollutants other than Criteria and HAP	Potential Emissions	
	PPH	TPY

List the method(s) used to calculate the potential emissions (include dates of any stack tests conducted, versions of software used, source and dates of emission factors, etc.).

Applicable Requirements

List all applicable requirements for this emission unit. For each applicable requirement, include the underlying rule/regulation citation and/or construction permit with the condition number. (Note: Title V permit condition numbers alone are not the underlying applicable requirements). If an emission limit is calculated based on the type of source and design capacity or if a standard is based on a design parameter, this information should also be included.

See Attachment I for applicable requirements, monitoring, recordkeeping, reporting and testing from existing Title V permit.

X Permit Shield

For all applicable requirements listed above, provide monitoring/testing/recordkeeping/reporting which shall be used to demonstrate compliance. If the method is based on a permit or rule, include the condition number or citation. (Note: Each requirement listed above must have an associated method of demonstrating compliance. If there is not already a required method in place, then a method must be proposed.)

See Attachment I for applicable requirements, monitoring, recordkeeping, reporting and testing from existing Title V permit.

Are you in compliance with all applicable requirements for this emission unit? X Yes No

If no, complete the **Schedule of Compliance Form** as ATTACHMENT F.

ATTACHMENT E - Emission Unit Form

Emission Unit Description: Storage Tank

Emission unit ID number: 8701	Emission unit name: Tank 8701	List any control devices associated with this emission unit: C-1087-1
---	---	---

Provide a description of the emission unit (type, method of operation, design parameters, etc.):
Storage of volatile organic compounds

Manufacturer:	Model number:	Serial number:
----------------------	----------------------	-----------------------

Construction date: See Attachment D Equipment Table	Installation date: See Attachment D Equipment Table	Modification date(s): See Attachment D Equipment Table
---	---	--

Design Capacity (examples: furnaces - tons/hr, tanks - gallons): See Attachment D Equipment Table

Maximum Hourly Throughput:	Maximum Annual Throughput:	Maximum Operating Schedule: 24 hrs/day, 365 days/yr
-----------------------------------	-----------------------------------	---

Fuel Usage Data (fill out all applicable fields)

Does this emission unit combust fuel? ___ Yes <u> X </u> No	If yes, is it? ___ Indirect Fired ___ Direct Fired
--	--

Maximum design heat input and/or maximum horsepower rating:	Type and Btu/hr rating of burners:
--	---

List the primary fuel type(s) and if applicable, the secondary fuel type(s). For each fuel type listed, provide the maximum hourly and annual fuel usage for each.

Describe each fuel expected to be used during the term of the permit.

Fuel Type	Max. Sulfur Content	Max. Ash Content	BTU Value

Union Carbide Corporation South Charleston Facility – TRITON

Emissions Data		
Criteria Pollutants	Potential Emissions	
	PPH	TPY
Carbon Monoxide (CO)		
Nitrogen Oxides (NO _x)		
Lead (Pb)		
Particulate Matter (PM _{2.5})		
Particulate Matter (PM ₁₀)		
Total Particulate Matter (TSP)		
Sulfur Dioxide (SO ₂)		
Volatile Organic Compounds (VOC)		
Hazardous Air Pollutants	Potential Emissions	
	PPH	TPY
Regulated Pollutants other than Criteria and HAP	Potential Emissions	
	PPH	TPY

List the method(s) used to calculate the potential emissions (include dates of any stack tests conducted, versions of software used, source and dates of emission factors, etc.).

Applicable Requirements

List all applicable requirements for this emission unit. For each applicable requirement, include the underlying rule/regulation citation and/or construction permit with the condition number. (Note: Title V permit condition numbers alone are not the underlying applicable requirements). If an emission limit is calculated based on the type of source and design capacity or if a standard is based on a design parameter, this information should also be included.

See Attachment I for applicable requirements, monitoring, recordkeeping, reporting and testing from existing Title V permit.

 X Permit Shield

For all applicable requirements listed above, provide monitoring/testing/recordkeeping/reporting which shall be used to demonstrate compliance. If the method is based on a permit or rule, include the condition number or citation. (Note: Each requirement listed above must have an associated method of demonstrating compliance. If there is not already a required method in place, then a method must be proposed.)

See Attachment I for applicable requirements, monitoring, recordkeeping, reporting and testing from existing Title V permit.

Are you in compliance with all applicable requirements for this emission unit? X Yes No

If no, complete the **Schedule of Compliance Form** as **ATTACHMENT F**.

ATTACHMENT E - Emission Unit Form

Emission Unit Description: Reactor

Emission unit ID number: 8600	Emission unit name: 8600 Reactor	List any control devices associated with this emission unit: C8130 or none
---	--	--

Provide a description of the emission unit (type, method of operation, design parameters, etc.):

Manufacturer:	Model number:	Serial number:
----------------------	----------------------	-----------------------

Construction date: See Attachment D Equipment Table	Installation date: See Attachment D Equipment Table	Modification date(s): See Attachment D Equipment Table
---	---	--

Design Capacity (examples: furnaces - tons/hr, tanks - gallons): See Attachment D Equipment Table

Maximum Hourly Throughput:	Maximum Annual Throughput:	Maximum Operating Schedule: 24 hrs/day, 365 days/yr
-----------------------------------	-----------------------------------	---

Fuel Usage Data (fill out all applicable fields)

Does this emission unit combust fuel? ___ Yes <u> X </u> No	If yes, is it? ___ Indirect Fired ___ Direct Fired
--	--

Maximum design heat input and/or maximum horsepower rating:	Type and Btu/hr rating of burners:
--	---

List the primary fuel type(s) and if applicable, the secondary fuel type(s). For each fuel type listed, provide the maximum hourly and annual fuel usage for each.

Describe each fuel expected to be used during the term of the permit.

Fuel Type	Max. Sulfur Content	Max. Ash Content	BTU Value

Union Carbide Corporation South Charleston Facility – TRITON

<i>Emissions Data</i>		
Criteria Pollutants	Potential Emissions	
	PPH	TPY
Carbon Monoxide (CO)		
Nitrogen Oxides (NO _x)		
Lead (Pb)		
Particulate Matter (PM _{2.5})		
Particulate Matter (PM ₁₀)		
Total Particulate Matter (TSP)		
Sulfur Dioxide (SO ₂)		
Volatile Organic Compounds (VOC)		
Hazardous Air Pollutants	Potential Emissions	
	PPH	TPY
Regulated Pollutants other than Criteria and HAP	Potential Emissions	
	PPH	TPY

List the method(s) used to calculate the potential emissions (include dates of any stack tests conducted, versions of software used, source and dates of emission factors, etc.).

Applicable Requirements

List all applicable requirements for this emission unit. For each applicable requirement, include the underlying rule/regulation citation and/or construction permit with the condition number. (Note: Title V permit condition numbers alone are not the underlying applicable requirements). If an emission limit is calculated based on the type of source and design capacity or if a standard is based on a design parameter, this information should also be included.

See Attachment I for applicable requirements, monitoring, recordkeeping, reporting and testing from existing Title V permit.

X Permit Shield

For all applicable requirements listed above, provide monitoring/testing/recordkeeping/reporting which shall be used to demonstrate compliance. If the method is based on a permit or rule, include the condition number or citation. (Note: Each requirement listed above must have an associated method of demonstrating compliance. If there is not already a required method in place, then a method must be proposed.)

See Attachment I for applicable requirements, monitoring, recordkeeping, reporting and testing from existing Title V permit.

Are you in compliance with all applicable requirements for this emission unit? X Yes No

If no, complete the **Schedule of Compliance Form** as **ATTACHMENT F**.

ATTACHMENT E - Emission Unit Form

Emission Unit Description: Vessel

Emission unit ID number: 8518	Emission unit name: Vessel 8518	List any control devices associated with this emission unit:
---	---	---

Provide a description of the emission unit (type, method of operation, design parameters, etc.):

Manufacturer:	Model number:	Serial number:
Construction date: See Attachment D Equipment Table	Installation date: See Attachment D Equipment Table	Modification date(s): See Attachment D Equipment Table

Design Capacity (examples: furnaces - tons/hr, tanks - gallons): See Attachment D Equipment Table

Maximum Hourly Throughput:	Maximum Annual Throughput:	Maximum Operating Schedule: 24 hrs/day, 365 days/yr
-----------------------------------	-----------------------------------	---

Fuel Usage Data (fill out all applicable fields)

Does this emission unit combust fuel? ___Yes <u>X</u> No	If yes, is it? ___ Indirect Fired ___Direct Fired
Maximum design heat input and/or maximum horsepower rating:	Type and Btu/hr rating of burners:

List the primary fuel type(s) and if applicable, the secondary fuel type(s). For each fuel type listed, provide the maximum hourly and annual fuel usage for each.

Describe each fuel expected to be used during the term of the permit.

Fuel Type	Max. Sulfur Content	Max. Ash Content	BTU Value

Union Carbide Corporation South Charleston Facility – TRITON

<i>Emissions Data</i>		
Criteria Pollutants	Potential Emissions	
	PPH	TPY
Carbon Monoxide (CO)		
Nitrogen Oxides (NO _x)		
Lead (Pb)		
Particulate Matter (PM _{2.5})		
Particulate Matter (PM ₁₀)		
Total Particulate Matter (TSP)		
Sulfur Dioxide (SO ₂)		
Volatile Organic Compounds (VOC)		
Hazardous Air Pollutants	Potential Emissions	
	PPH	TPY
Regulated Pollutants other than Criteria and HAP	Potential Emissions	
	PPH	TPY

List the method(s) used to calculate the potential emissions (include dates of any stack tests conducted, versions of software used, source and dates of emission factors, etc.).

Applicable Requirements

List all applicable requirements for this emission unit. For each applicable requirement, include the underlying rule/regulation citation and/or construction permit with the condition number. (Note: Title V permit condition numbers alone are not the underlying applicable requirements). If an emission limit is calculated based on the type of source and design capacity or if a standard is based on a design parameter, this information should also be included.

See Attachment I for applicable requirements, monitoring, recordkeeping, reporting and testing from existing Title V permit.

X Permit Shield

For all applicable requirements listed above, provide monitoring/testing/recordkeeping/reporting which shall be used to demonstrate compliance. If the method is based on a permit or rule, include the condition number or citation. (Note: Each requirement listed above must have an associated method of demonstrating compliance. If there is not already a required method in place, then a method must be proposed.)

See Attachment I for applicable requirements, monitoring, recordkeeping, reporting and testing from existing Title V permit.

Are you in compliance with all applicable requirements for this emission unit? X Yes No

If no, complete the **Schedule of Compliance Form** as **ATTACHMENT F**.

ATTACHMENT E - Emission Unit Form

Emission Unit Description: Storage Tank

Emission unit ID number: 8520	Emission unit name: Tank 8520	List any control devices associated with this emission unit:
---	---	---

Provide a description of the emission unit (type, method of operation, design parameters, etc.):

Storage of volatile organic compounds

Manufacturer:	Model number:	Serial number:
----------------------	----------------------	-----------------------

Construction date: See Attachment D Equipment Table	Installation date: See Attachment D Equipment Table	Modification date(s): See Attachment D Equipment Table
---	---	--

Design Capacity (examples: furnaces - tons/hr, tanks - gallons): See Attachment D Equipment Table

Maximum Hourly Throughput:	Maximum Annual Throughput:	Maximum Operating Schedule: 24 hrs/day, 365 days/yr
-----------------------------------	-----------------------------------	---

Fuel Usage Data (fill out all applicable fields)

Does this emission unit combust fuel? ___Yes <u>X</u> No	If yes, is it? ___ Indirect Fired ___Direct Fired
---	---

Maximum design heat input and/or maximum horsepower rating:	Type and Btu/hr rating of burners:
--	---

List the primary fuel type(s) and if applicable, the secondary fuel type(s). For each fuel type listed, provide the maximum hourly and annual fuel usage for each.

Describe each fuel expected to be used during the term of the permit.

Fuel Type	Max. Sulfur Content	Max. Ash Content	BTU Value

Union Carbide Corporation South Charleston Facility – TRITON

<i>Emissions Data</i>		
Criteria Pollutants	Potential Emissions	
	PPH	TPY
Carbon Monoxide (CO)		
Nitrogen Oxides (NO _x)		
Lead (Pb)		
Particulate Matter (PM _{2.5})		
Particulate Matter (PM ₁₀)		
Total Particulate Matter (TSP)		
Sulfur Dioxide (SO ₂)		
Volatile Organic Compounds (VOC)		
Hazardous Air Pollutants	Potential Emissions	
	PPH	TPY
Regulated Pollutants other than Criteria and HAP	Potential Emissions	
	PPH	TPY

List the method(s) used to calculate the potential emissions (include dates of any stack tests conducted, versions of software used, source and dates of emission factors, etc.).

Applicable Requirements

List all applicable requirements for this emission unit. For each applicable requirement, include the underlying rule/regulation citation and/or construction permit with the condition number. (Note: Title V permit condition numbers alone are not the underlying applicable requirements). If an emission limit is calculated based on the type of source and design capacity or if a standard is based on a design parameter, this information should also be included.

See Attachment I for applicable requirements, monitoring, recordkeeping, reporting and testing from existing Title V permit.

Permit Shield

For all applicable requirements listed above, provide monitoring/testing/recordkeeping/reporting which shall be used to demonstrate compliance. If the method is based on a permit or rule, include the condition number or citation. (Note: Each requirement listed above must have an associated method of demonstrating compliance. If there is not already a required method in place, then a method must be proposed.)

See Attachment I for applicable requirements, monitoring, recordkeeping, reporting and testing from existing Title V permit.

Are you in compliance with all applicable requirements for this emission unit? Yes No

If no, complete the **Schedule of Compliance Form** as ATTACHMENT F.

ATTACHMENT E - Emission Unit Form

Emission Unit Description: Hotwell

Emission unit ID number: 8515	Emission unit name: LCAP Hotwell	List any control devices associated with this emission unit: N/A
---	--	--

Provide a description of the emission unit (type, method of operation, design parameters, etc.):

Manufacturer:	Model number:	Serial number:
----------------------	----------------------	-----------------------

Construction date: See Attachment D Equipment Table	Installation date: See Attachment D Equipment Table	Modification date(s): See Attachment D Equipment Table
---	---	--

Design Capacity (examples: furnaces - tons/hr, tanks - gallons): See Attachment D Equipment Table

Maximum Hourly Throughput:	Maximum Annual Throughput:	Maximum Operating Schedule: 24 hrs/day, 365 days/yr
-----------------------------------	-----------------------------------	---

Fuel Usage Data (fill out all applicable fields)

Does this emission unit combust fuel? ___ Yes <u>X</u> No	If yes, is it? ___ Indirect Fired ___ Direct Fired
--	--

Maximum design heat input and/or maximum horsepower rating:	Type and Btu/hr rating of burners:
--	---

List the primary fuel type(s) and if applicable, the secondary fuel type(s). For each fuel type listed, provide the maximum hourly and annual fuel usage for each.

Describe each fuel expected to be used during the term of the permit.

Fuel Type	Max. Sulfur Content	Max. Ash Content	BTU Value

Union Carbide Corporation South Charleston Facility – TRITON

<i>Emissions Data</i>		
Criteria Pollutants	Potential Emissions	
	PPH	TPY
Carbon Monoxide (CO)		
Nitrogen Oxides (NO _x)		
Lead (Pb)		
Particulate Matter (PM _{2.5})		
Particulate Matter (PM ₁₀)		
Total Particulate Matter (TSP)		
Sulfur Dioxide (SO ₂)		
Volatile Organic Compounds (VOC)		
Hazardous Air Pollutants	Potential Emissions	
	PPH	TPY
Regulated Pollutants other than Criteria and HAP	Potential Emissions	
	PPH	TPY

List the method(s) used to calculate the potential emissions (include dates of any stack tests conducted, versions of software used, source and dates of emission factors, etc.).

Applicable Requirements

List all applicable requirements for this emission unit. For each applicable requirement, include the underlying rule/regulation citation and/or construction permit with the condition number. (Note: Title V permit condition numbers alone are not the underlying applicable requirements). If an emission limit is calculated based on the type of source and design capacity or if a standard is based on a design parameter, this information should also be included.

See Attachment I for applicable requirements, monitoring, recordkeeping, reporting and testing from existing Title V permit.

X Permit Shield

For all applicable requirements listed above, provide monitoring/testing/recordkeeping/reporting which shall be used to demonstrate compliance. If the method is based on a permit or rule, include the condition number or citation. (Note: Each requirement listed above must have an associated method of demonstrating compliance. If there is not already a required method in place, then a method must be proposed.)

See Attachment I for applicable requirements, monitoring, recordkeeping, reporting and testing from existing Title V permit.

Are you in compliance with all applicable requirements for this emission unit? X Yes No

If no, complete the **Schedule of Compliance Form** as **ATTACHMENT F**.

ATTACHMENT E - Emission Unit Form

Emission Unit Description: Storage Tank

Emission unit ID number: 8420	Emission unit name: Tank 8420	List any control devices associated with this emission unit:
---	---	---

Provide a description of the emission unit (type, method of operation, design parameters, etc.):
Storage of volatile organic compounds

Manufacturer:	Model number:	Serial number:
----------------------	----------------------	-----------------------

Construction date: See Attachment D Equipment Table	Installation date: See Attachment D Equipment Table	Modification date(s): See Attachment D Equipment Table
---	---	--

Design Capacity (examples: furnaces - tons/hr, tanks - gallons): See Attachment D Equipment Table

Maximum Hourly Throughput:	Maximum Annual Throughput:	Maximum Operating Schedule: 24 hrs/day, 365 days/yr
-----------------------------------	-----------------------------------	---

Fuel Usage Data (fill out all applicable fields)

Does this emission unit combust fuel? ___ Yes <u> X </u> No	If yes, is it? ___ Indirect Fired ___ Direct Fired
--	--

Maximum design heat input and/or maximum horsepower rating:	Type and Btu/hr rating of burners:
--	---

List the primary fuel type(s) and if applicable, the secondary fuel type(s). For each fuel type listed, provide the maximum hourly and annual fuel usage for each.

Describe each fuel expected to be used during the term of the permit.

Fuel Type	Max. Sulfur Content	Max. Ash Content	BTU Value

Union Carbide Corporation South Charleston Facility – TRITON

<i>Emissions Data</i>		
Criteria Pollutants	Potential Emissions	
	PPH	TPY
Carbon Monoxide (CO)		
Nitrogen Oxides (NO _x)		
Lead (Pb)		
Particulate Matter (PM _{2.5})		
Particulate Matter (PM ₁₀)		
Total Particulate Matter (TSP)		
Sulfur Dioxide (SO ₂)		
Volatile Organic Compounds (VOC)		
Hazardous Air Pollutants	Potential Emissions	
	PPH	TPY
Regulated Pollutants other than Criteria and HAP	Potential Emissions	
	PPH	TPY

List the method(s) used to calculate the potential emissions (include dates of any stack tests conducted, versions of software used, source and dates of emission factors, etc.).

Applicable Requirements

List all applicable requirements for this emission unit. For each applicable requirement, include the underlying rule/regulation citation and/or construction permit with the condition number. (Note: Title V permit condition numbers alone are not the underlying applicable requirements). If an emission limit is calculated based on the type of source and design capacity or if a standard is based on a design parameter, this information should also be included.

See Attachment I for applicable requirements, monitoring, recordkeeping, reporting and testing from existing Title V permit.

X Permit Shield

For all applicable requirements listed above, provide monitoring/testing/recordkeeping/reporting which shall be used to demonstrate compliance. If the method is based on a permit or rule, include the condition number or citation. (Note: Each requirement listed above must have an associated method of demonstrating compliance. If there is not already a required method in place, then a method must be proposed.)

See Attachment I for applicable requirements, monitoring, recordkeeping, reporting and testing from existing Title V permit.

Are you in compliance with all applicable requirements for this emission unit? X Yes No

If no, complete the **Schedule of Compliance Form** as **ATTACHMENT F**.

ATTACHMENT E - Emission Unit Form

<i>Emission Unit Description: Storage Tank</i>			
Emission unit ID number: 8435	Emission unit name: Tank 8435	List any control devices associated with this emission unit:	
Provide a description of the emission unit (type, method of operation, design parameters, etc.): Storage of volatile organic compounds			
Manufacturer:	Model number:	Serial number:	
Construction date: See Attachment D Equipment Table	Installation date: See Attachment D Equipment Table	Modification date(s): See Attachment D Equipment Table	
Design Capacity (examples: furnaces - tons/hr, tanks - gallons): See Attachment D Equipment Table			
Maximum Hourly Throughput:	Maximum Annual Throughput:	Maximum Operating Schedule: 24 hrs/day, 365 days/yr	
Fuel Usage Data (fill out all applicable fields)			
Does this emission unit combust fuel? ___ Yes <input checked="" type="checkbox"/> No		If yes, is it? ___ Indirect Fired ___ Direct Fired	
Maximum design heat input and/or maximum horsepower rating:		Type and Btu/hr rating of burners:	
List the primary fuel type(s) and if applicable, the secondary fuel type(s). For each fuel type listed, provide the maximum hourly and annual fuel usage for each.			
Describe each fuel expected to be used during the term of the permit.			
Fuel Type	Max. Sulfur Content	Max. Ash Content	BTU Value

Union Carbide Corporation South Charleston Facility – TRITON

<i>Emissions Data</i>		
Criteria Pollutants	Potential Emissions	
	PPH	TPY
Carbon Monoxide (CO)		
Nitrogen Oxides (NO _x)		
Lead (Pb)		
Particulate Matter (PM _{2.5})		
Particulate Matter (PM ₁₀)		
Total Particulate Matter (TSP)		
Sulfur Dioxide (SO ₂)		
Volatile Organic Compounds (VOC)		
Hazardous Air Pollutants	Potential Emissions	
	PPH	TPY
Regulated Pollutants other than Criteria and HAP	Potential Emissions	
	PPH	TPY

List the method(s) used to calculate the potential emissions (include dates of any stack tests conducted, versions of software used, source and dates of emission factors, etc.).

Applicable Requirements

List all applicable requirements for this emission unit. For each applicable requirement, include the underlying rule/regulation citation and/or construction permit with the condition number. (Note: Title V permit condition numbers alone are not the underlying applicable requirements). If an emission limit is calculated based on the type of source and design capacity or if a standard is based on a design parameter, this information should also be included.

See Attachment I for applicable requirements, monitoring, recordkeeping, reporting and testing from existing Title V permit.

X Permit Shield

For all applicable requirements listed above, provide monitoring/testing/recordkeeping/reporting which shall be used to demonstrate compliance. If the method is based on a permit or rule, include the condition number or citation. (Note: Each requirement listed above must have an associated method of demonstrating compliance. If there is not already a required method in place, then a method must be proposed.)

See Attachment I for applicable requirements, monitoring, recordkeeping, reporting and testing from existing Title V permit.

Are you in compliance with all applicable requirements for this emission unit? X Yes No

If no, complete the **Schedule of Compliance Form** as **ATTACHMENT F**.

ATTACHMENT E - Emission Unit Form

Emission Unit Description: Storage Tank

Emission unit ID number: 8433	Emission unit name: Tank 8433	List any control devices associated with this emission unit:
---	---	---

Provide a description of the emission unit (type, method of operation, design parameters, etc.):

Storage of phosphoric acid

Manufacturer:	Model number:	Serial number:
Construction date: See Attachment D Equipment Table	Installation date: See Attachment D Equipment Table	Modification date(s): See Attachment D Equipment Table

Design Capacity (examples: furnaces - tons/hr, tanks - gallons): See Attachment D Equipment Table

Maximum Hourly Throughput:	Maximum Annual Throughput:	Maximum Operating Schedule: 24 hrs/day, 365 days/yr
-----------------------------------	-----------------------------------	---

Fuel Usage Data (fill out all applicable fields)

Does this emission unit combust fuel? ___Yes <u>X</u> No	If yes, is it? ___ Indirect Fired ___ Direct Fired
Maximum design heat input and/or maximum horsepower rating:	Type and Btu/hr rating of burners:

List the primary fuel type(s) and if applicable, the secondary fuel type(s). For each fuel type listed, provide the maximum hourly and annual fuel usage for each.

Describe each fuel expected to be used during the term of the permit.

Fuel Type	Max. Sulfur Content	Max. Ash Content	BTU Value

Union Carbide Corporation South Charleston Facility – TRITON

<i>Emissions Data</i>		
Criteria Pollutants	Potential Emissions	
	PPH	TPY
Carbon Monoxide (CO)		
Nitrogen Oxides (NO _x)		
Lead (Pb)		
Particulate Matter (PM _{2.5})		
Particulate Matter (PM ₁₀)		
Total Particulate Matter (TSP)		
Sulfur Dioxide (SO ₂)		
Volatile Organic Compounds (VOC)		
Hazardous Air Pollutants	Potential Emissions	
	PPH	TPY
Regulated Pollutants other than Criteria and HAP	Potential Emissions	
	PPH	TPY

List the method(s) used to calculate the potential emissions (include dates of any stack tests conducted, versions of software used, source and dates of emission factors, etc.).

Applicable Requirements

List all applicable requirements for this emission unit. For each applicable requirement, include the underlying rule/regulation citation and/or construction permit with the condition number. (Note: Title V permit condition numbers alone are not the underlying applicable requirements). If an emission limit is calculated based on the type of source and design capacity or if a standard is based on a design parameter, this information should also be included.

See Attachment I for applicable requirements, monitoring, recordkeeping, reporting and testing from existing Title V permit.

 X Permit Shield

For all applicable requirements listed above, provide monitoring/testing/recordkeeping/reporting which shall be used to demonstrate compliance. If the method is based on a permit or rule, include the condition number or citation. (Note: Each requirement listed above must have an associated method of demonstrating compliance. If there is not already a required method in place, then a method must be proposed.)

See Attachment I for applicable requirements, monitoring, recordkeeping, reporting and testing from existing Title V permit.

Are you in compliance with all applicable requirements for this emission unit? X Yes No

If no, complete the **Schedule of Compliance Form** as ATTACHMENT F.

ATTACHMENT E - Emission Unit Form

Emission Unit Description: Reactor

Emission unit ID number: 8400	Emission unit name: 8400 Reactor	List any control devices associated with this emission unit: C8110 or none	
Provide a description of the emission unit (type, method of operation, design parameters, etc.): Reactor			
Manufacturer:	Model number:	Serial number:	
Construction date: See Attachment D Equipment Table	Installation date: See Attachment D Equipment Table	Modification date(s): See Attachment D Equipment Table	
Design Capacity (examples: furnaces - tons/hr, tanks - gallons): See Attachment D Equipment Table			
Maximum Hourly Throughput:	Maximum Annual Throughput:	Maximum Operating Schedule: 24 hrs/day, 365 days/yr	
Fuel Usage Data (fill out all applicable fields)			
Does this emission unit combust fuel? ___Yes <input checked="" type="checkbox"/> No		If yes, is it? ___ Indirect Fired ___ Direct Fired	
Maximum design heat input and/or maximum horsepower rating:		Type and Btu/hr rating of burners:	
List the primary fuel type(s) and if applicable, the secondary fuel type(s). For each fuel type listed, provide the maximum hourly and annual fuel usage for each.			
Describe each fuel expected to be used during the term of the permit.			
Fuel Type	Max. Sulfur Content	Max. Ash Content	BTU Value

Union Carbide Corporation South Charleston Facility – TRITON

<i>Emissions Data</i>		
Criteria Pollutants	Potential Emissions	
	PPH	TPY
Carbon Monoxide (CO)		
Nitrogen Oxides (NO _x)		
Lead (Pb)		
Particulate Matter (PM _{2.5})		
Particulate Matter (PM ₁₀)		
Total Particulate Matter (TSP)		
Sulfur Dioxide (SO ₂)		
Volatile Organic Compounds (VOC)		
Hazardous Air Pollutants	Potential Emissions	
	PPH	TPY
Regulated Pollutants other than Criteria and HAP	Potential Emissions	
	PPH	TPY

List the method(s) used to calculate the potential emissions (include dates of any stack tests conducted, versions of software used, source and dates of emission factors, etc.).

Applicable Requirements

List all applicable requirements for this emission unit. For each applicable requirement, include the underlying rule/regulation citation and/or construction permit with the condition number. (Note: Title V permit condition numbers alone are not the underlying applicable requirements). If an emission limit is calculated based on the type of source and design capacity or if a standard is based on a design parameter, this information should also be included.

See Attachment I for applicable requirements, monitoring, recordkeeping, reporting and testing from existing Title V permit.

Permit Shield

For all applicable requirements listed above, provide monitoring/testing/recordkeeping/reporting which shall be used to demonstrate compliance. If the method is based on a permit or rule, include the condition number or citation. (Note: Each requirement listed above must have an associated method of demonstrating compliance. If there is not already a required method in place, then a method must be proposed.)

See Attachment I for applicable requirements, monitoring, recordkeeping, reporting and testing from existing Title V permit.

Are you in compliance with all applicable requirements for this emission unit? Yes No

If no, complete the **Schedule of Compliance Form** as ATTACHMENT F.

ATTACHMENT E - Emission Unit Form

Emission Unit Description: Hotwell

Emission unit ID number: 8415	Emission unit name: Triad Hotwell	List any control devices associated with this emission unit: N/A
---	---	--

Provide a description of the emission unit (type, method of operation, design parameters, etc.):

Manufacturer:	Model number:	Serial number:
----------------------	----------------------	-----------------------

Construction date: See Attachment D Equipment Table	Installation date: See Attachment D Equipment Table	Modification date(s): See Attachment D Equipment Table
---	---	--

Design Capacity (examples: furnaces - tons/hr, tanks - gallons): See Attachment D Equipment Table

Maximum Hourly Throughput:	Maximum Annual Throughput:	Maximum Operating Schedule: 24 hrs/day, 365 days/yr
-----------------------------------	-----------------------------------	---

Fuel Usage Data (fill out all applicable fields)

Does this emission unit combust fuel? ___ Yes <input checked="" type="checkbox"/> No	If yes, is it? ___ Indirect Fired ___ Direct Fired
---	--

Maximum design heat input and/or maximum horsepower rating:	Type and Btu/hr rating of burners:
--	---

List the primary fuel type(s) and if applicable, the secondary fuel type(s). For each fuel type listed, provide the maximum hourly and annual fuel usage for each.

Describe each fuel expected to be used during the term of the permit.

Fuel Type	Max. Sulfur Content	Max. Ash Content	BTU Value

Union Carbide Corporation South Charleston Facility – TRITON

<i>Emissions Data</i>		
Criteria Pollutants	Potential Emissions	
	PPH	TPY
Carbon Monoxide (CO)		
Nitrogen Oxides (NO _x)		
Lead (Pb)		
Particulate Matter (PM _{2.5})		
Particulate Matter (PM ₁₀)		
Total Particulate Matter (TSP)		
Sulfur Dioxide (SO ₂)		
Volatile Organic Compounds (VOC)		
Hazardous Air Pollutants	Potential Emissions	
	PPH	TPY
Regulated Pollutants other than Criteria and HAP	Potential Emissions	
	PPH	TPY

List the method(s) used to calculate the potential emissions (include dates of any stack tests conducted, versions of software used, source and dates of emission factors, etc.).

Applicable Requirements

List all applicable requirements for this emission unit. For each applicable requirement, include the underlying rule/regulation citation and/or construction permit with the condition number. (Note: Title V permit condition numbers alone are not the underlying applicable requirements). If an emission limit is calculated based on the type of source and design capacity or if a standard is based on a design parameter, this information should also be included.

See Attachment I for applicable requirements, monitoring, recordkeeping, reporting and testing from existing Title V permit.

X Permit Shield

For all applicable requirements listed above, provide monitoring/testing/recordkeeping/reporting which shall be used to demonstrate compliance. If the method is based on a permit or rule, include the condition number or citation. (Note: Each requirement listed above must have an associated method of demonstrating compliance. If there is not already a required method in place, then a method must be proposed.)

See Attachment I for applicable requirements, monitoring, recordkeeping, reporting and testing from existing Title V permit.

Are you in compliance with all applicable requirements for this emission unit? X Yes No

If no, complete the **Schedule of Compliance Form** as **ATTACHMENT F**.

ATTACHMENT E - Emission Unit Form

Emission Unit Description: Storage Tank

Emission unit ID number: 8392	Emission unit name: Tank 8392	List any control devices associated with this emission unit:
---	---	---

Provide a description of the emission unit (type, method of operation, design parameters, etc.):
Storage of volatile organic liquid

Manufacturer:	Model number:	Serial number:
----------------------	----------------------	-----------------------

Construction date: See Attachment D Equipment Table	Installation date: See Attachment D Equipment Table	Modification date(s): See Attachment D Equipment Table
---	---	--

Design Capacity (examples: furnaces - tons/hr, tanks - gallons): See Attachment D Equipment Table

Maximum Hourly Throughput:	Maximum Annual Throughput:	Maximum Operating Schedule: 24 hrs/day, 365 days/yr
-----------------------------------	-----------------------------------	---

Fuel Usage Data (fill out all applicable fields)

Does this emission unit combust fuel? ___ Yes <u> X </u> No	If yes, is it? ___ Indirect Fired ___ Direct Fired
--	--

Maximum design heat input and/or maximum horsepower rating:	Type and Btu/hr rating of burners:
--	---

List the primary fuel type(s) and if applicable, the secondary fuel type(s). For each fuel type listed, provide the maximum hourly and annual fuel usage for each.

Describe each fuel expected to be used during the term of the permit.

Fuel Type	Max. Sulfur Content	Max. Ash Content	BTU Value

Union Carbide Corporation South Charleston Facility – TRITON

<i>Emissions Data</i>		
Criteria Pollutants	Potential Emissions	
	PPH	TPY
Carbon Monoxide (CO)		
Nitrogen Oxides (NO _x)		
Lead (Pb)		
Particulate Matter (PM _{2.5})		
Particulate Matter (PM ₁₀)		
Total Particulate Matter (TSP)		
Sulfur Dioxide (SO ₂)		
Volatile Organic Compounds (VOC)		
Hazardous Air Pollutants	Potential Emissions	
	PPH	TPY
Regulated Pollutants other than Criteria and HAP	Potential Emissions	
	PPH	TPY

List the method(s) used to calculate the potential emissions (include dates of any stack tests conducted, versions of software used, source and dates of emission factors, etc.).

Applicable Requirements

List all applicable requirements for this emission unit. For each applicable requirement, include the underlying rule/regulation citation and/or construction permit with the condition number. (Note: Title V permit condition numbers alone are not the underlying applicable requirements). If an emission limit is calculated based on the type of source and design capacity or if a standard is based on a design parameter, this information should also be included.

See Attachment I for applicable requirements, monitoring, recordkeeping, reporting and testing from existing Title V permit.

X Permit Shield

For all applicable requirements listed above, provide monitoring/testing/recordkeeping/reporting which shall be used to demonstrate compliance. If the method is based on a permit or rule, include the condition number or citation. (Note: Each requirement listed above must have an associated method of demonstrating compliance. If there is not already a required method in place, then a method must be proposed.)

See Attachment I for applicable requirements, monitoring, recordkeeping, reporting and testing from existing Title V permit.

Are you in compliance with all applicable requirements for this emission unit? X Yes No

If no, complete the **Schedule of Compliance Form** as **ATTACHMENT F**.

ATTACHMENT E - Emission Unit Form

Emission Unit Description: Storage Tank			
Emission unit ID number: 8393	Emission unit name: Tank 8393	List any control devices associated with this emission unit:	
Provide a description of the emission unit (type, method of operation, design parameters, etc.): Storage of volatile organic liquid			
Manufacturer:	Model number:	Serial number:	
Construction date: See Attachment D Equipment Table	Installation date: See Attachment D Equipment Table	Modification date(s): See Attachment D Equipment Table	
Design Capacity (examples: furnaces - tons/hr, tanks - gallons): See Attachment D Equipment Table			
Maximum Hourly Throughput:	Maximum Annual Throughput:	Maximum Operating Schedule: 24 hrs/day, 365 days/yr	
Fuel Usage Data (fill out all applicable fields)			
Does this emission unit combust fuel? ___ Yes <input checked="" type="checkbox"/> No		If yes, is it? ___ Indirect Fired ___ Direct Fired	
Maximum design heat input and/or maximum horsepower rating:		Type and Btu/hr rating of burners:	
List the primary fuel type(s) and if applicable, the secondary fuel type(s). For each fuel type listed, provide the maximum hourly and annual fuel usage for each.			
Describe each fuel expected to be used during the term of the permit.			
Fuel Type	Max. Sulfur Content	Max. Ash Content	BTU Value

Union Carbide Corporation South Charleston Facility – TRITON

<i>Emissions Data</i>		
Criteria Pollutants	Potential Emissions	
	PPH	TPY
Carbon Monoxide (CO)		
Nitrogen Oxides (NO _x)		
Lead (Pb)		
Particulate Matter (PM _{2.5})		
Particulate Matter (PM ₁₀)		
Total Particulate Matter (TSP)		
Sulfur Dioxide (SO ₂)		
Volatile Organic Compounds (VOC)		
Hazardous Air Pollutants	Potential Emissions	
	PPH	TPY
Regulated Pollutants other than Criteria and HAP	Potential Emissions	
	PPH	TPY

List the method(s) used to calculate the potential emissions (include dates of any stack tests conducted, versions of software used, source and dates of emission factors, etc.).

Applicable Requirements

List all applicable requirements for this emission unit. For each applicable requirement, include the underlying rule/regulation citation and/or construction permit with the condition number. (Note: Title V permit condition numbers alone are not the underlying applicable requirements). If an emission limit is calculated based on the type of source and design capacity or if a standard is based on a design parameter, this information should also be included.

See Attachment I for applicable requirements, monitoring, recordkeeping, reporting and testing from existing Title V permit.

Permit Shield

For all applicable requirements listed above, provide monitoring/testing/recordkeeping/reporting which shall be used to demonstrate compliance. If the method is based on a permit or rule, include the condition number or citation. (Note: Each requirement listed above must have an associated method of demonstrating compliance. If there is not already a required method in place, then a method must be proposed.)

See Attachment I for applicable requirements, monitoring, recordkeeping, reporting and testing from existing Title V permit.

Are you in compliance with all applicable requirements for this emission unit? Yes No

If no, complete the **Schedule of Compliance Form** as ATTACHMENT F.

ATTACHMENT E - Emission Unit Form

Emission Unit Description: Storage Tank

Emission unit ID number: 8391	Emission unit name: Tank 8391	List any control devices associated with this emission unit:
---	---	---

Provide a description of the emission unit (type, method of operation, design parameters, etc.):
Storage of volatile organic liquid

Manufacturer:	Model number:	Serial number:
----------------------	----------------------	-----------------------

Construction date: See Attachment D Equipment Table	Installation date: See Attachment D Equipment Table	Modification date(s): See Attachment D Equipment Table
---	---	--

Design Capacity (examples: furnaces - tons/hr, tanks - gallons): See Attachment D Equipment Table

Maximum Hourly Throughput:	Maximum Annual Throughput:	Maximum Operating Schedule: 24 hrs/day, 365 days/yr
-----------------------------------	-----------------------------------	---

Fuel Usage Data (fill out all applicable fields)

Does this emission unit combust fuel? ___ Yes <u> X </u> No	If yes, is it? ___ Indirect Fired ___ Direct Fired
--	--

Maximum design heat input and/or maximum horsepower rating:	Type and Btu/hr rating of burners:
--	---

List the primary fuel type(s) and if applicable, the secondary fuel type(s). For each fuel type listed, provide the maximum hourly and annual fuel usage for each.

Describe each fuel expected to be used during the term of the permit.

Fuel Type	Max. Sulfur Content	Max. Ash Content	BTU Value

Union Carbide Corporation South Charleston Facility – TRITON

<i>Emissions Data</i>		
Criteria Pollutants	Potential Emissions	
	PPH	TPY
Carbon Monoxide (CO)		
Nitrogen Oxides (NO _x)		
Lead (Pb)		
Particulate Matter (PM _{2.5})		
Particulate Matter (PM ₁₀)		
Total Particulate Matter (TSP)		
Sulfur Dioxide (SO ₂)		
Volatile Organic Compounds (VOC)		
Hazardous Air Pollutants	Potential Emissions	
	PPH	TPY
Regulated Pollutants other than Criteria and HAP	Potential Emissions	
	PPH	TPY
<p>List the method(s) used to calculate the potential emissions (include dates of any stack tests conducted, versions of software used, source and dates of emission factors, etc.).</p>		

Applicable Requirements

List all applicable requirements for this emission unit. For each applicable requirement, include the underlying rule/regulation citation and/or construction permit with the condition number. (Note: Title V permit condition numbers alone are not the underlying applicable requirements). If an emission limit is calculated based on the type of source and design capacity or if a standard is based on a design parameter, this information should also be included.

See Attachment I for applicable requirements, monitoring, recordkeeping, reporting and testing from existing Title V permit.

X Permit Shield

For all applicable requirements listed above, provide monitoring/testing/recordkeeping/reporting which shall be used to demonstrate compliance. If the method is based on a permit or rule, include the condition number or citation. (Note: Each requirement listed above must have an associated method of demonstrating compliance. If there is not already a required method in place, then a method must be proposed.)

See Attachment I for applicable requirements, monitoring, recordkeeping, reporting and testing from existing Title V permit.

Are you in compliance with all applicable requirements for this emission unit? X Yes No

If no, complete the **Schedule of Compliance Form** as **ATTACHMENT F**.

ATTACHMENT E - Emission Unit Form

Emission Unit Description: Storage Tank			
Emission unit ID number: 8390	Emission unit name: Tank 8390	List any control devices associated with this emission unit:	
Provide a description of the emission unit (type, method of operation, design parameters, etc.): Storage of volatile organic liquid			
Manufacturer:	Model number:	Serial number:	
Construction date: See Attachment D Equipment Table	Installation date: See Attachment D Equipment Table	Modification date(s): See Attachment D Equipment Table	
Design Capacity (examples: furnaces - tons/hr, tanks - gallons): See Attachment D Equipment Table			
Maximum Hourly Throughput:	Maximum Annual Throughput:	Maximum Operating Schedule: 24 hrs/day, 365 days/yr	
Fuel Usage Data (fill out all applicable fields)			
Does this emission unit combust fuel? ___Yes <input checked="" type="checkbox"/> No		If yes, is it? ___ Indirect Fired ___ Direct Fired	
Maximum design heat input and/or maximum horsepower rating:		Type and Btu/hr rating of burners:	
List the primary fuel type(s) and if applicable, the secondary fuel type(s). For each fuel type listed, provide the maximum hourly and annual fuel usage for each.			
Describe each fuel expected to be used during the term of the permit.			
Fuel Type	Max. Sulfur Content	Max. Ash Content	BTU Value

Union Carbide Corporation South Charleston Facility – TRITON

<i>Emissions Data</i>		
Criteria Pollutants	Potential Emissions	
	PPH	TPY
Carbon Monoxide (CO)		
Nitrogen Oxides (NO _x)		
Lead (Pb)		
Particulate Matter (PM _{2.5})		
Particulate Matter (PM ₁₀)		
Total Particulate Matter (TSP)		
Sulfur Dioxide (SO ₂)		
Volatile Organic Compounds (VOC)		
Hazardous Air Pollutants	Potential Emissions	
	PPH	TPY
Regulated Pollutants other than Criteria and HAP	Potential Emissions	
	PPH	TPY

List the method(s) used to calculate the potential emissions (include dates of any stack tests conducted, versions of software used, source and dates of emission factors, etc.).

Applicable Requirements

List all applicable requirements for this emission unit. For each applicable requirement, include the underlying rule/regulation citation and/or construction permit with the condition number. (Note: Title V permit condition numbers alone are not the underlying applicable requirements). If an emission limit is calculated based on the type of source and design capacity or if a standard is based on a design parameter, this information should also be included.

See Attachment I for applicable requirements, monitoring, recordkeeping, reporting and testing from existing Title V permit.

Permit Shield

For all applicable requirements listed above, provide monitoring/testing/recordkeeping/reporting which shall be used to demonstrate compliance. If the method is based on a permit or rule, include the condition number or citation. (Note: Each requirement listed above must have an associated method of demonstrating compliance. If there is not already a required method in place, then a method must be proposed.)

See Attachment I for applicable requirements, monitoring, recordkeeping, reporting and testing from existing Title V permit.

Are you in compliance with all applicable requirements for this emission unit? Yes No

If no, complete the **Schedule of Compliance Form** as ATTACHMENT F.

ATTACHMENT E - Emission Unit Form

Emission Unit Description: Storage Tank

Emission unit ID number: 8380	Emission unit name: Tank 8380	List any control devices associated with this emission unit:
---	---	---

Provide a description of the emission unit (type, method of operation, design parameters, etc.):
Storage of volatile organic liquid

Manufacturer:	Model number:	Serial number:
----------------------	----------------------	-----------------------

Construction date: See Attachment D Equipment Table	Installation date: See Attachment D Equipment Table	Modification date(s): See Attachment D Equipment Table
---	---	--

Design Capacity (examples: furnaces - tons/hr, tanks - gallons): See Attachment D Equipment Table

Maximum Hourly Throughput:	Maximum Annual Throughput:	Maximum Operating Schedule: 24 hrs/day, 365 days/yr
-----------------------------------	-----------------------------------	---

Fuel Usage Data (fill out all applicable fields)

Does this emission unit combust fuel? ___ Yes <u> X </u> No	If yes, is it? ___ Indirect Fired ___ Direct Fired
--	--

Maximum design heat input and/or maximum horsepower rating:	Type and Btu/hr rating of burners:
--	---

List the primary fuel type(s) and if applicable, the secondary fuel type(s). For each fuel type listed, provide the maximum hourly and annual fuel usage for each.

Describe each fuel expected to be used during the term of the permit.

Fuel Type	Max. Sulfur Content	Max. Ash Content	BTU Value

Union Carbide Corporation South Charleston Facility – TRITON

<i>Emissions Data</i>		
Criteria Pollutants	Potential Emissions	
	PPH	TPY
Carbon Monoxide (CO)		
Nitrogen Oxides (NO _x)		
Lead (Pb)		
Particulate Matter (PM _{2.5})		
Particulate Matter (PM ₁₀)		
Total Particulate Matter (TSP)		
Sulfur Dioxide (SO ₂)		
Volatile Organic Compounds (VOC)		
Hazardous Air Pollutants	Potential Emissions	
	PPH	TPY
Regulated Pollutants other than Criteria and HAP	Potential Emissions	
	PPH	TPY

List the method(s) used to calculate the potential emissions (include dates of any stack tests conducted, versions of software used, source and dates of emission factors, etc.).

Applicable Requirements

List all applicable requirements for this emission unit. For each applicable requirement, include the underlying rule/regulation citation and/or construction permit with the condition number. (Note: Title V permit condition numbers alone are not the underlying applicable requirements). If an emission limit is calculated based on the type of source and design capacity or if a standard is based on a design parameter, this information should also be included.

See Attachment I for applicable requirements, monitoring, recordkeeping, reporting and testing from existing Title V permit.

Permit Shield

For all applicable requirements listed above, provide monitoring/testing/recordkeeping/reporting which shall be used to demonstrate compliance. If the method is based on a permit or rule, include the condition number or citation. (Note: Each requirement listed above must have an associated method of demonstrating compliance. If there is not already a required method in place, then a method must be proposed.)

See Attachment I for applicable requirements, monitoring, recordkeeping, reporting and testing from existing Title V permit.

Are you in compliance with all applicable requirements for this emission unit? Yes No

If no, complete the **Schedule of Compliance Form** as ATTACHMENT F.

ATTACHMENT E - Emission Unit Form

Emission Unit Description: Storage Tank

Emission unit ID number: 8381	Emission unit name: Tank 8381	List any control devices associated with this emission unit:
---	---	---

Provide a description of the emission unit (type, method of operation, design parameters, etc.):
Storage of volatile organic liquid

Manufacturer:	Model number:	Serial number:
----------------------	----------------------	-----------------------

Construction date: See Attachment D Equipment Table	Installation date: See Attachment D Equipment Table	Modification date(s): See Attachment D Equipment Table
---	---	--

Design Capacity (examples: furnaces - tons/hr, tanks - gallons): See Attachment D Equipment Table

Maximum Hourly Throughput:	Maximum Annual Throughput:	Maximum Operating Schedule: 24 hrs/day, 365 days/yr
-----------------------------------	-----------------------------------	---

Fuel Usage Data (fill out all applicable fields)

Does this emission unit combust fuel? ___Yes <u>X</u> No	If yes, is it? ___ Indirect Fired ___ Direct Fired
---	--

Maximum design heat input and/or maximum horsepower rating:	Type and Btu/hr rating of burners:
--	---

List the primary fuel type(s) and if applicable, the secondary fuel type(s). For each fuel type listed, provide the maximum hourly and annual fuel usage for each.

Describe each fuel expected to be used during the term of the permit.

Fuel Type	Max. Sulfur Content	Max. Ash Content	BTU Value

Union Carbide Corporation South Charleston Facility – TRITON

<i>Emissions Data</i>		
Criteria Pollutants	Potential Emissions	
	PPH	TPY
Carbon Monoxide (CO)		
Nitrogen Oxides (NO _x)		
Lead (Pb)		
Particulate Matter (PM _{2.5})		
Particulate Matter (PM ₁₀)		
Total Particulate Matter (TSP)		
Sulfur Dioxide (SO ₂)		
Volatile Organic Compounds (VOC)		
Hazardous Air Pollutants	Potential Emissions	
	PPH	TPY
Regulated Pollutants other than Criteria and HAP	Potential Emissions	
	PPH	TPY

List the method(s) used to calculate the potential emissions (include dates of any stack tests conducted, versions of software used, source and dates of emission factors, etc.).

Applicable Requirements

List all applicable requirements for this emission unit. For each applicable requirement, include the underlying rule/regulation citation and/or construction permit with the condition number. (Note: Title V permit condition numbers alone are not the underlying applicable requirements). If an emission limit is calculated based on the type of source and design capacity or if a standard is based on a design parameter, this information should also be included.

See Attachment I for applicable requirements, monitoring, recordkeeping, reporting and testing from existing Title V permit.

X Permit Shield

For all applicable requirements listed above, provide monitoring/testing/recordkeeping/reporting which shall be used to demonstrate compliance. If the method is based on a permit or rule, include the condition number or citation. (Note: Each requirement listed above must have an associated method of demonstrating compliance. If there is not already a required method in place, then a method must be proposed.)

See Attachment I for applicable requirements, monitoring, recordkeeping, reporting and testing from existing Title V permit.

Are you in compliance with all applicable requirements for this emission unit? X Yes No

If no, complete the **Schedule of Compliance Form** as ATTACHMENT F.

ATTACHMENT E - Emission Unit Form

Emission Unit Description: Storage Tank

Emission unit ID number: 8383	Emission unit name: Tank 8383	List any control devices associated with this emission unit:
---	---	---

Provide a description of the emission unit (type, method of operation, design parameters, etc.):
Storage of volatile organic liquid

Manufacturer:	Model number:	Serial number:
----------------------	----------------------	-----------------------

Construction date: See Attachment D Equipment Table	Installation date: See Attachment D Equipment Table	Modification date(s): See Attachment D Equipment Table
---	---	--

Design Capacity (examples: furnaces - tons/hr, tanks - gallons): See Attachment D Equipment Table

Maximum Hourly Throughput:	Maximum Annual Throughput:	Maximum Operating Schedule: 24 hrs/day, 365 days/yr
-----------------------------------	-----------------------------------	---

Fuel Usage Data (fill out all applicable fields)

Does this emission unit combust fuel? ___Yes <u>X</u> No	If yes, is it? ___ Indirect Fired ___ Direct Fired
---	--

Maximum design heat input and/or maximum horsepower rating:	Type and Btu/hr rating of burners:
--	---

List the primary fuel type(s) and if applicable, the secondary fuel type(s). For each fuel type listed, provide the maximum hourly and annual fuel usage for each.

Describe each fuel expected to be used during the term of the permit.

Fuel Type	Max. Sulfur Content	Max. Ash Content	BTU Value

Union Carbide Corporation South Charleston Facility – TRITON

<i>Emissions Data</i>		
Criteria Pollutants	Potential Emissions	
	PPH	TPY
Carbon Monoxide (CO)		
Nitrogen Oxides (NO _x)		
Lead (Pb)		
Particulate Matter (PM _{2.5})		
Particulate Matter (PM ₁₀)		
Total Particulate Matter (TSP)		
Sulfur Dioxide (SO ₂)		
Volatile Organic Compounds (VOC)		
Hazardous Air Pollutants	Potential Emissions	
	PPH	TPY
Regulated Pollutants other than Criteria and HAP	Potential Emissions	
	PPH	TPY

List the method(s) used to calculate the potential emissions (include dates of any stack tests conducted, versions of software used, source and dates of emission factors, etc.).

Applicable Requirements

List all applicable requirements for this emission unit. For each applicable requirement, include the underlying rule/regulation citation and/or construction permit with the condition number. (Note: Title V permit condition numbers alone are not the underlying applicable requirements). If an emission limit is calculated based on the type of source and design capacity or if a standard is based on a design parameter, this information should also be included.

See Attachment I for applicable requirements, monitoring, recordkeeping, reporting and testing from existing Title V permit.

 X Permit Shield

For all applicable requirements listed above, provide monitoring/testing/recordkeeping/reporting which shall be used to demonstrate compliance. If the method is based on a permit or rule, include the condition number or citation. (Note: Each requirement listed above must have an associated method of demonstrating compliance. If there is not already a required method in place, then a method must be proposed.)

See Attachment I for applicable requirements, monitoring, recordkeeping, reporting and testing from existing Title V permit.

Are you in compliance with all applicable requirements for this emission unit? X Yes No

If no, complete the **Schedule of Compliance Form** as **ATTACHMENT F**.

ATTACHMENT E - Emission Unit Form

Emission Unit Description: Storage Tank

Emission unit ID number: 8382	Emission unit name: Tank 8382	List any control devices associated with this emission unit: C8130
---	---	--

Provide a description of the emission unit (type, method of operation, design parameters, etc.):
Storage of volatile organic liquid

Manufacturer:	Model number:	Serial number:
----------------------	----------------------	-----------------------

Construction date: See Attachment D Equipment Table	Installation date: See Attachment D Equipment Table	Modification date(s): See Attachment D Equipment Table
---	---	--

Design Capacity (examples: furnaces - tons/hr, tanks - gallons): See Attachment D Equipment Table

Maximum Hourly Throughput:	Maximum Annual Throughput:	Maximum Operating Schedule: 24 hrs/day, 365 days/yr
-----------------------------------	-----------------------------------	---

Fuel Usage Data (fill out all applicable fields)

Does this emission unit combust fuel? ___Yes <u>X</u> No	If yes, is it? ___ Indirect Fired ___ Direct Fired
---	--

Maximum design heat input and/or maximum horsepower rating:	Type and Btu/hr rating of burners:
--	---

List the primary fuel type(s) and if applicable, the secondary fuel type(s). For each fuel type listed, provide the maximum hourly and annual fuel usage for each.

Describe each fuel expected to be used during the term of the permit.

Fuel Type	Max. Sulfur Content	Max. Ash Content	BTU Value

Union Carbide Corporation South Charleston Facility – TRITON

<i>Emissions Data</i>		
Criteria Pollutants	Potential Emissions	
	PPH	TPY
Carbon Monoxide (CO)		
Nitrogen Oxides (NO _x)		
Lead (Pb)		
Particulate Matter (PM _{2.5})		
Particulate Matter (PM ₁₀)		
Total Particulate Matter (TSP)		
Sulfur Dioxide (SO ₂)		
Volatile Organic Compounds (VOC)		
Hazardous Air Pollutants	Potential Emissions	
	PPH	TPY
Regulated Pollutants other than Criteria and HAP	Potential Emissions	
	PPH	TPY

List the method(s) used to calculate the potential emissions (include dates of any stack tests conducted, versions of software used, source and dates of emission factors, etc.).

Applicable Requirements

List all applicable requirements for this emission unit. For each applicable requirement, include the underlying rule/regulation citation and/or construction permit with the condition number. (Note: Title V permit condition numbers alone are not the underlying applicable requirements). If an emission limit is calculated based on the type of source and design capacity or if a standard is based on a design parameter, this information should also be included.

See Attachment I for applicable requirements, monitoring, recordkeeping, reporting and testing from existing Title V permit.

X Permit Shield

For all applicable requirements listed above, provide monitoring/testing/recordkeeping/reporting which shall be used to demonstrate compliance. If the method is based on a permit or rule, include the condition number or citation. (Note: Each requirement listed above must have an associated method of demonstrating compliance. If there is not already a required method in place, then a method must be proposed.)

See Attachment I for applicable requirements, monitoring, recordkeeping, reporting and testing from existing Title V permit.

Are you in compliance with all applicable requirements for this emission unit? X Yes No

If no, complete the **Schedule of Compliance Form** as **ATTACHMENT F**.

ATTACHMENT E - Emission Unit Form

Emission Unit Description: Storage Tank			
Emission unit ID number: 8375	Emission unit name: Tank 8375	List any control devices associated with this emission unit:	
Provide a description of the emission unit (type, method of operation, design parameters, etc.): Storage of volatile organic liquid			
Manufacturer:	Model number:	Serial number:	
Construction date: See Attachment D Equipment Table	Installation date: See Attachment D Equipment Table	Modification date(s): See Attachment D Equipment Table	
Design Capacity (examples: furnaces - tons/hr, tanks - gallons): See Attachment D Equipment Table			
Maximum Hourly Throughput:	Maximum Annual Throughput:	Maximum Operating Schedule: 24 hrs/day, 365 days/yr	
Fuel Usage Data (fill out all applicable fields)			
Does this emission unit combust fuel? ___Yes <input checked="" type="checkbox"/> No		If yes, is it? ___ Indirect Fired ___ Direct Fired	
Maximum design heat input and/or maximum horsepower rating:		Type and Btu/hr rating of burners:	
List the primary fuel type(s) and if applicable, the secondary fuel type(s). For each fuel type listed, provide the maximum hourly and annual fuel usage for each.			
Describe each fuel expected to be used during the term of the permit.			
Fuel Type	Max. Sulfur Content	Max. Ash Content	BTU Value

Union Carbide Corporation South Charleston Facility – TRITON

<i>Emissions Data</i>		
Criteria Pollutants	Potential Emissions	
	PPH	TPY
Carbon Monoxide (CO)		
Nitrogen Oxides (NO _x)		
Lead (Pb)		
Particulate Matter (PM _{2.5})		
Particulate Matter (PM ₁₀)		
Total Particulate Matter (TSP)		
Sulfur Dioxide (SO ₂)		
Volatile Organic Compounds (VOC)		
Hazardous Air Pollutants	Potential Emissions	
	PPH	TPY
Regulated Pollutants other than Criteria and HAP	Potential Emissions	
	PPH	TPY

List the method(s) used to calculate the potential emissions (include dates of any stack tests conducted, versions of software used, source and dates of emission factors, etc.).

Applicable Requirements

List all applicable requirements for this emission unit. For each applicable requirement, include the underlying rule/regulation citation and/or construction permit with the condition number. (Note: Title V permit condition numbers alone are not the underlying applicable requirements). If an emission limit is calculated based on the type of source and design capacity or if a standard is based on a design parameter, this information should also be included.

See Attachment I for applicable requirements, monitoring, recordkeeping, reporting and testing from existing Title V permit.

Permit Shield

For all applicable requirements listed above, provide monitoring/testing/recordkeeping/reporting which shall be used to demonstrate compliance. If the method is based on a permit or rule, include the condition number or citation. (Note: Each requirement listed above must have an associated method of demonstrating compliance. If there is not already a required method in place, then a method must be proposed.)

See Attachment I for applicable requirements, monitoring, recordkeeping, reporting and testing from existing Title V permit.

Are you in compliance with all applicable requirements for this emission unit? Yes No

If no, complete the **Schedule of Compliance Form** as ATTACHMENT F.

ATTACHMENT E - Emission Unit Form

Emission Unit Description: Storage Tank

Emission unit ID number: 8376	Emission unit name: Tank 8376	List any control devices associated with this emission unit:
---	---	---

Provide a description of the emission unit (type, method of operation, design parameters, etc.):
Storage of volatile organic liquid

Manufacturer:	Model number:	Serial number:
----------------------	----------------------	-----------------------

Construction date: See Attachment D Equipment Table	Installation date: See Attachment D Equipment Table	Modification date(s): See Attachment D Equipment Table
---	---	--

Design Capacity (examples: furnaces - tons/hr, tanks - gallons): See Attachment D Equipment Table

Maximum Hourly Throughput:	Maximum Annual Throughput:	Maximum Operating Schedule: 24 hrs/day, 365 days/yr
-----------------------------------	-----------------------------------	---

Fuel Usage Data (fill out all applicable fields)

Does this emission unit combust fuel? ___Yes <u>X</u> No	If yes, is it? ___ Indirect Fired ___ Direct Fired
---	--

Maximum design heat input and/or maximum horsepower rating:	Type and Btu/hr rating of burners:
--	---

List the primary fuel type(s) and if applicable, the secondary fuel type(s). For each fuel type listed, provide the maximum hourly and annual fuel usage for each.

Describe each fuel expected to be used during the term of the permit.

Fuel Type	Max. Sulfur Content	Max. Ash Content	BTU Value

Union Carbide Corporation South Charleston Facility – TRITON

<i>Emissions Data</i>		
Criteria Pollutants	Potential Emissions	
	PPH	TPY
Carbon Monoxide (CO)		
Nitrogen Oxides (NO _x)		
Lead (Pb)		
Particulate Matter (PM _{2.5})		
Particulate Matter (PM ₁₀)		
Total Particulate Matter (TSP)		
Sulfur Dioxide (SO ₂)		
Volatile Organic Compounds (VOC)		
Hazardous Air Pollutants	Potential Emissions	
	PPH	TPY
Regulated Pollutants other than Criteria and HAP	Potential Emissions	
	PPH	TPY

List the method(s) used to calculate the potential emissions (include dates of any stack tests conducted, versions of software used, source and dates of emission factors, etc.).

Applicable Requirements

List all applicable requirements for this emission unit. For each applicable requirement, include the underlying rule/regulation citation and/or construction permit with the condition number. (Note: Title V permit condition numbers alone are not the underlying applicable requirements). If an emission limit is calculated based on the type of source and design capacity or if a standard is based on a design parameter, this information should also be included.

See Attachment I for applicable requirements, monitoring, recordkeeping, reporting and testing from existing Title V permit.

X Permit Shield

For all applicable requirements listed above, provide monitoring/testing/recordkeeping/reporting which shall be used to demonstrate compliance. If the method is based on a permit or rule, include the condition number or citation. (Note: Each requirement listed above must have an associated method of demonstrating compliance. If there is not already a required method in place, then a method must be proposed.)

See Attachment I for applicable requirements, monitoring, recordkeeping, reporting and testing from existing Title V permit.

Are you in compliance with all applicable requirements for this emission unit? X Yes No

If no, complete the **Schedule of Compliance Form** as **ATTACHMENT F**.

ATTACHMENT E - Emission Unit Form

Emission Unit Description: Storage Tank			
Emission unit ID number: 8371	Emission unit name: Tank 8371	List any control devices associated with this emission unit:	
Provide a description of the emission unit (type, method of operation, design parameters, etc.): Storage of volatile organic liquid			
Manufacturer:	Model number:	Serial number:	
Construction date: See Attachment D Equipment Table	Installation date: See Attachment D Equipment Table	Modification date(s): See Attachment D Equipment Table	
Design Capacity (examples: furnaces - tons/hr, tanks - gallons): See Attachment D Equipment Table			
Maximum Hourly Throughput:	Maximum Annual Throughput:	Maximum Operating Schedule: 24 hrs/day, 365 days/yr	
Fuel Usage Data (fill out all applicable fields)			
Does this emission unit combust fuel? ___ Yes <input checked="" type="checkbox"/> No		If yes, is it? ___ Indirect Fired ___ Direct Fired	
Maximum design heat input and/or maximum horsepower rating:		Type and Btu/hr rating of burners:	
List the primary fuel type(s) and if applicable, the secondary fuel type(s). For each fuel type listed, provide the maximum hourly and annual fuel usage for each.			
Describe each fuel expected to be used during the term of the permit.			
Fuel Type	Max. Sulfur Content	Max. Ash Content	BTU Value

Union Carbide Corporation South Charleston Facility – TRITON

<i>Emissions Data</i>		
Criteria Pollutants	Potential Emissions	
	PPH	TPY
Carbon Monoxide (CO)		
Nitrogen Oxides (NO _x)		
Lead (Pb)		
Particulate Matter (PM _{2.5})		
Particulate Matter (PM ₁₀)		
Total Particulate Matter (TSP)		
Sulfur Dioxide (SO ₂)		
Volatile Organic Compounds (VOC)		
Hazardous Air Pollutants	Potential Emissions	
	PPH	TPY
Regulated Pollutants other than Criteria and HAP	Potential Emissions	
	PPH	TPY

List the method(s) used to calculate the potential emissions (include dates of any stack tests conducted, versions of software used, source and dates of emission factors, etc.).

Applicable Requirements

List all applicable requirements for this emission unit. For each applicable requirement, include the underlying rule/regulation citation and/or construction permit with the condition number. (Note: Title V permit condition numbers alone are not the underlying applicable requirements). If an emission limit is calculated based on the type of source and design capacity or if a standard is based on a design parameter, this information should also be included.

See Attachment I for applicable requirements, monitoring, recordkeeping, reporting and testing from existing Title V permit.

X Permit Shield

For all applicable requirements listed above, provide monitoring/testing/recordkeeping/reporting which shall be used to demonstrate compliance. If the method is based on a permit or rule, include the condition number or citation. (Note: Each requirement listed above must have an associated method of demonstrating compliance. If there is not already a required method in place, then a method must be proposed.)

See Attachment I for applicable requirements, monitoring, recordkeeping, reporting and testing from existing Title V permit.

Are you in compliance with all applicable requirements for this emission unit? X Yes No

If no, complete the **Schedule of Compliance Form** as **ATTACHMENT F**.

ATTACHMENT E - Emission Unit Form

Emission Unit Description: Storage Tank

Emission unit ID number: 8373	Emission unit name: Tank 8373	List any control devices associated with this emission unit:
---	---	---

Provide a description of the emission unit (type, method of operation, design parameters, etc.):
Storage of volatile organic liquid

Manufacturer:	Model number:	Serial number:
----------------------	----------------------	-----------------------

Construction date: See Attachment D Equipment Table	Installation date: See Attachment D Equipment Table	Modification date(s): See Attachment D Equipment Table
---	---	--

Design Capacity (examples: furnaces - tons/hr, tanks - gallons): See Attachment D Equipment Table

Maximum Hourly Throughput:	Maximum Annual Throughput:	Maximum Operating Schedule: 24 hrs/day, 365 days/yr
-----------------------------------	-----------------------------------	---

Fuel Usage Data (fill out all applicable fields)

Does this emission unit combust fuel? ___Yes <u>X</u> No	If yes, is it? ___ Indirect Fired ___ Direct Fired
---	--

Maximum design heat input and/or maximum horsepower rating:	Type and Btu/hr rating of burners:
--	---

List the primary fuel type(s) and if applicable, the secondary fuel type(s). For each fuel type listed, provide the maximum hourly and annual fuel usage for each.

Describe each fuel expected to be used during the term of the permit.

Fuel Type	Max. Sulfur Content	Max. Ash Content	BTU Value

Union Carbide Corporation South Charleston Facility – TRITON

<i>Emissions Data</i>		
Criteria Pollutants	Potential Emissions	
	PPH	TPY
Carbon Monoxide (CO)		
Nitrogen Oxides (NO _x)		
Lead (Pb)		
Particulate Matter (PM _{2.5})		
Particulate Matter (PM ₁₀)		
Total Particulate Matter (TSP)		
Sulfur Dioxide (SO ₂)		
Volatile Organic Compounds (VOC)		
Hazardous Air Pollutants	Potential Emissions	
	PPH	TPY
Regulated Pollutants other than Criteria and HAP	Potential Emissions	
	PPH	TPY

List the method(s) used to calculate the potential emissions (include dates of any stack tests conducted, versions of software used, source and dates of emission factors, etc.).

Applicable Requirements

List all applicable requirements for this emission unit. For each applicable requirement, include the underlying rule/regulation citation and/or construction permit with the condition number. (Note: Title V permit condition numbers alone are not the underlying applicable requirements). If an emission limit is calculated based on the type of source and design capacity or if a standard is based on a design parameter, this information should also be included.

See Attachment I for applicable requirements, monitoring, recordkeeping, reporting and testing from existing Title V permit.

X Permit Shield

For all applicable requirements listed above, provide monitoring/testing/recordkeeping/reporting which shall be used to demonstrate compliance. If the method is based on a permit or rule, include the condition number or citation. (Note: Each requirement listed above must have an associated method of demonstrating compliance. If there is not already a required method in place, then a method must be proposed.)

See Attachment I for applicable requirements, monitoring, recordkeeping, reporting and testing from existing Title V permit.

Are you in compliance with all applicable requirements for this emission unit? X Yes No

If no, complete the **Schedule of Compliance Form** as ATTACHMENT F.

ATTACHMENT E - Emission Unit Form

Emission Unit Description: Storage Tank

Emission unit ID number: 8372	Emission unit name: Tank 8372	List any control devices associated with this emission unit:
---	---	---

Provide a description of the emission unit (type, method of operation, design parameters, etc.):
Storage of sulfuric acid

Manufacturer:	Model number:	Serial number:
----------------------	----------------------	-----------------------

Construction date: See Attachment D Equipment Table	Installation date: See Attachment D Equipment Table	Modification date(s): See Attachment D Equipment Table
---	---	--

Design Capacity (examples: furnaces - tons/hr, tanks - gallons): See Attachment D Equipment Table

Maximum Hourly Throughput:	Maximum Annual Throughput:	Maximum Operating Schedule: 24 hrs/day, 365 days/yr
-----------------------------------	-----------------------------------	---

Fuel Usage Data (fill out all applicable fields)

Does this emission unit combust fuel? ___Yes <u>X</u> No	If yes, is it? ___ Indirect Fired ___ Direct Fired
---	--

Maximum design heat input and/or maximum horsepower rating:	Type and Btu/hr rating of burners:
--	---

List the primary fuel type(s) and if applicable, the secondary fuel type(s). For each fuel type listed, provide the maximum hourly and annual fuel usage for each.

Describe each fuel expected to be used during the term of the permit.

Fuel Type	Max. Sulfur Content	Max. Ash Content	BTU Value

Union Carbide Corporation South Charleston Facility – TRITON

<i>Emissions Data</i>		
Criteria Pollutants	Potential Emissions	
	PPH	TPY
Carbon Monoxide (CO)		
Nitrogen Oxides (NO _x)		
Lead (Pb)		
Particulate Matter (PM _{2.5})		
Particulate Matter (PM ₁₀)		
Total Particulate Matter (TSP)		
Sulfur Dioxide (SO ₂)		
Volatile Organic Compounds (VOC)		
Hazardous Air Pollutants	Potential Emissions	
	PPH	TPY
Regulated Pollutants other than Criteria and HAP	Potential Emissions	
	PPH	TPY

List the method(s) used to calculate the potential emissions (include dates of any stack tests conducted, versions of software used, source and dates of emission factors, etc.).

Applicable Requirements

List all applicable requirements for this emission unit. For each applicable requirement, include the underlying rule/regulation citation and/or construction permit with the condition number. (Note: Title V permit condition numbers alone are not the underlying applicable requirements). If an emission limit is calculated based on the type of source and design capacity or if a standard is based on a design parameter, this information should also be included.

See Attachment I for applicable requirements, monitoring, recordkeeping, reporting and testing from existing Title V permit.

X Permit Shield

For all applicable requirements listed above, provide monitoring/testing/recordkeeping/reporting which shall be used to demonstrate compliance. If the method is based on a permit or rule, include the condition number or citation. (Note: Each requirement listed above must have an associated method of demonstrating compliance. If there is not already a required method in place, then a method must be proposed.)

See Attachment I for applicable requirements, monitoring, recordkeeping, reporting and testing from existing Title V permit.

Are you in compliance with all applicable requirements for this emission unit? X Yes No

If no, complete the **Schedule of Compliance Form** as **ATTACHMENT F**.

ATTACHMENT E - Emission Unit Form

Emission Unit Description: Storage Tank

Emission unit ID number: 8370	Emission unit name: Tank 8370	List any control devices associated with this emission unit: C8130
---	---	--

Provide a description of the emission unit (type, method of operation, design parameters, etc.):

Storage of volatile organic liquid

Manufacturer:	Model number:	Serial number:
Construction date: See Attachment D Equipment Table	Installation date: See Attachment D Equipment Table	Modification date(s): See Attachment D Equipment Table

Design Capacity (examples: furnaces - tons/hr, tanks - gallons): See Attachment D Equipment Table

Maximum Hourly Throughput:	Maximum Annual Throughput:	Maximum Operating Schedule: 24 hrs/day, 365 days/yr
-----------------------------------	-----------------------------------	---

Fuel Usage Data (fill out all applicable fields)

Does this emission unit combust fuel? ___ Yes <u> X </u> No	If yes, is it? ___ Indirect Fired ___ Direct Fired
Maximum design heat input and/or maximum horsepower rating:	Type and Btu/hr rating of burners:

List the primary fuel type(s) and if applicable, the secondary fuel type(s). For each fuel type listed, provide the maximum hourly and annual fuel usage for each.

Describe each fuel expected to be used during the term of the permit.

Fuel Type	Max. Sulfur Content	Max. Ash Content	BTU Value

Union Carbide Corporation South Charleston Facility – TRITON

<i>Emissions Data</i>		
Criteria Pollutants	Potential Emissions	
	PPH	TPY
Carbon Monoxide (CO)		
Nitrogen Oxides (NO _x)		
Lead (Pb)		
Particulate Matter (PM _{2.5})		
Particulate Matter (PM ₁₀)		
Total Particulate Matter (TSP)		
Sulfur Dioxide (SO ₂)		
Volatile Organic Compounds (VOC)		
Hazardous Air Pollutants	Potential Emissions	
	PPH	TPY
Regulated Pollutants other than Criteria and HAP	Potential Emissions	
	PPH	TPY

List the method(s) used to calculate the potential emissions (include dates of any stack tests conducted, versions of software used, source and dates of emission factors, etc.).

Applicable Requirements

List all applicable requirements for this emission unit. For each applicable requirement, include the underlying rule/regulation citation and/or construction permit with the condition number. (Note: Title V permit condition numbers alone are not the underlying applicable requirements). If an emission limit is calculated based on the type of source and design capacity or if a standard is based on a design parameter, this information should also be included.

See Attachment I for applicable requirements, monitoring, recordkeeping, reporting and testing from existing Title V permit.

X Permit Shield

For all applicable requirements listed above, provide monitoring/testing/recordkeeping/reporting which shall be used to demonstrate compliance. If the method is based on a permit or rule, include the condition number or citation. (Note: Each requirement listed above must have an associated method of demonstrating compliance. If there is not already a required method in place, then a method must be proposed.)

See Attachment I for applicable requirements, monitoring, recordkeeping, reporting and testing from existing Title V permit.

Are you in compliance with all applicable requirements for this emission unit? X Yes No

If no, complete the **Schedule of Compliance Form** as ATTACHMENT F.

ATTACHMENT E - Emission Unit Form

Emission Unit Description: Storage Tank

Emission unit ID number: 8363	Emission unit name: Tank 8363	List any control devices associated with this emission unit: C8130
---	---	--

Provide a description of the emission unit (type, method of operation, design parameters, etc.):

Storage of volatile organic liquid

Manufacturer:	Model number:	Serial number:
Construction date: See Attachment D Equipment Table	Installation date: See Attachment D Equipment Table	Modification date(s): See Attachment D Equipment Table

Design Capacity (examples: furnaces - tons/hr, tanks - gallons): See Attachment D Equipment Table

Maximum Hourly Throughput:	Maximum Annual Throughput:	Maximum Operating Schedule: 24 hrs/day, 365 days/yr
-----------------------------------	-----------------------------------	---

Fuel Usage Data (fill out all applicable fields)

Does this emission unit combust fuel? ___Yes <u>X</u> No	If yes, is it? ___ Indirect Fired ___ Direct Fired
Maximum design heat input and/or maximum horsepower rating:	Type and Btu/hr rating of burners:

List the primary fuel type(s) and if applicable, the secondary fuel type(s). For each fuel type listed, provide the maximum hourly and annual fuel usage for each.

Describe each fuel expected to be used during the term of the permit.

Fuel Type	Max. Sulfur Content	Max. Ash Content	BTU Value

Union Carbide Corporation South Charleston Facility – TRITON

<i>Emissions Data</i>		
Criteria Pollutants	Potential Emissions	
	PPH	TPY
Carbon Monoxide (CO)		
Nitrogen Oxides (NO _x)		
Lead (Pb)		
Particulate Matter (PM _{2.5})		
Particulate Matter (PM ₁₀)		
Total Particulate Matter (TSP)		
Sulfur Dioxide (SO ₂)		
Volatile Organic Compounds (VOC)		
Hazardous Air Pollutants	Potential Emissions	
	PPH	TPY
Regulated Pollutants other than Criteria and HAP	Potential Emissions	
	PPH	TPY

List the method(s) used to calculate the potential emissions (include dates of any stack tests conducted, versions of software used, source and dates of emission factors, etc.).

Applicable Requirements

List all applicable requirements for this emission unit. For each applicable requirement, include the underlying rule/regulation citation and/or construction permit with the condition number. (Note: Title V permit condition numbers alone are not the underlying applicable requirements). If an emission limit is calculated based on the type of source and design capacity or if a standard is based on a design parameter, this information should also be included.

See Attachment I for applicable requirements, monitoring, recordkeeping, reporting and testing from existing Title V permit.

X Permit Shield

For all applicable requirements listed above, provide monitoring/testing/recordkeeping/reporting which shall be used to demonstrate compliance. If the method is based on a permit or rule, include the condition number or citation. (Note: Each requirement listed above must have an associated method of demonstrating compliance. If there is not already a required method in place, then a method must be proposed.)

See Attachment I for applicable requirements, monitoring, recordkeeping, reporting and testing from existing Title V permit.

Are you in compliance with all applicable requirements for this emission unit? X Yes No

If no, complete the **Schedule of Compliance Form** as **ATTACHMENT F**.

ATTACHMENT E - Emission Unit Form

Emission Unit Description: Storage Tank

Emission unit ID number: 8364	Emission unit name: Tank 8364	List any control devices associated with this emission unit:
---	---	---

Provide a description of the emission unit (type, method of operation, design parameters, etc.):
Storage of volatile organic liquid

Manufacturer:	Model number:	Serial number:
----------------------	----------------------	-----------------------

Construction date: See Attachment D Equipment Table	Installation date: See Attachment D Equipment Table	Modification date(s): See Attachment D Equipment Table
---	---	--

Design Capacity (examples: furnaces - tons/hr, tanks - gallons): See Attachment D Equipment Table

Maximum Hourly Throughput:	Maximum Annual Throughput:	Maximum Operating Schedule: 24 hrs/day, 365 days/yr
-----------------------------------	-----------------------------------	---

Fuel Usage Data (fill out all applicable fields)

Does this emission unit combust fuel? ___Yes <u>X</u> No	If yes, is it? ___ Indirect Fired ___ Direct Fired
---	--

Maximum design heat input and/or maximum horsepower rating:	Type and Btu/hr rating of burners:
--	---

List the primary fuel type(s) and if applicable, the secondary fuel type(s). For each fuel type listed, provide the maximum hourly and annual fuel usage for each.

Describe each fuel expected to be used during the term of the permit.

Fuel Type	Max. Sulfur Content	Max. Ash Content	BTU Value

Union Carbide Corporation South Charleston Facility – TRITON

<i>Emissions Data</i>		
Criteria Pollutants	Potential Emissions	
	PPH	TPY
Carbon Monoxide (CO)		
Nitrogen Oxides (NO _x)		
Lead (Pb)		
Particulate Matter (PM _{2.5})		
Particulate Matter (PM ₁₀)		
Total Particulate Matter (TSP)		
Sulfur Dioxide (SO ₂)		
Volatile Organic Compounds (VOC)		
Hazardous Air Pollutants	Potential Emissions	
	PPH	TPY
Regulated Pollutants other than Criteria and HAP	Potential Emissions	
	PPH	TPY

List the method(s) used to calculate the potential emissions (include dates of any stack tests conducted, versions of software used, source and dates of emission factors, etc.).

Applicable Requirements

List all applicable requirements for this emission unit. For each applicable requirement, include the underlying rule/regulation citation and/or construction permit with the condition number. (Note: Title V permit condition numbers alone are not the underlying applicable requirements). If an emission limit is calculated based on the type of source and design capacity or if a standard is based on a design parameter, this information should also be included.

See Attachment I for applicable requirements, monitoring, recordkeeping, reporting and testing from existing Title V permit.

X Permit Shield

For all applicable requirements listed above, provide monitoring/testing/recordkeeping/reporting which shall be used to demonstrate compliance. If the method is based on a permit or rule, include the condition number or citation. (Note: Each requirement listed above must have an associated method of demonstrating compliance. If there is not already a required method in place, then a method must be proposed.)

See Attachment I for applicable requirements, monitoring, recordkeeping, reporting and testing from existing Title V permit.

Are you in compliance with all applicable requirements for this emission unit? X Yes No

If no, complete the **Schedule of Compliance Form** as **ATTACHMENT F**.

ATTACHMENT E - Emission Unit Form

Emission Unit Description: Storage Tank

Emission unit ID number: 8366	Emission unit name: Tank 8366	List any control devices associated with this emission unit:
---	---	---

Provide a description of the emission unit (type, method of operation, design parameters, etc.):

Storage of volatile organic liquid

Manufacturer:	Model number:	Serial number:
Construction date: See Attachment D Equipment Table	Installation date: See Attachment D Equipment Table	Modification date(s): See Attachment D Equipment Table

Design Capacity (examples: furnaces - tons/hr, tanks - gallons): See Attachment D Equipment Table

Maximum Hourly Throughput:	Maximum Annual Throughput:	Maximum Operating Schedule: 24 hrs/day, 365 days/yr
-----------------------------------	-----------------------------------	---

Fuel Usage Data (fill out all applicable fields)

Does this emission unit combust fuel? ___Yes <u>X</u> No	If yes, is it? ___ Indirect Fired ___ Direct Fired
Maximum design heat input and/or maximum horsepower rating:	Type and Btu/hr rating of burners:

List the primary fuel type(s) and if applicable, the secondary fuel type(s). For each fuel type listed, provide the maximum hourly and annual fuel usage for each.

Describe each fuel expected to be used during the term of the permit.

Fuel Type	Max. Sulfur Content	Max. Ash Content	BTU Value

Union Carbide Corporation South Charleston Facility – TRITON

<i>Emissions Data</i>		
Criteria Pollutants	Potential Emissions	
	PPH	TPY
Carbon Monoxide (CO)		
Nitrogen Oxides (NO _x)		
Lead (Pb)		
Particulate Matter (PM _{2.5})		
Particulate Matter (PM ₁₀)		
Total Particulate Matter (TSP)		
Sulfur Dioxide (SO ₂)		
Volatile Organic Compounds (VOC)		
Hazardous Air Pollutants	Potential Emissions	
	PPH	TPY
Regulated Pollutants other than Criteria and HAP	Potential Emissions	
	PPH	TPY

List the method(s) used to calculate the potential emissions (include dates of any stack tests conducted, versions of software used, source and dates of emission factors, etc.).

Applicable Requirements

List all applicable requirements for this emission unit. For each applicable requirement, include the underlying rule/regulation citation and/or construction permit with the condition number. (Note: Title V permit condition numbers alone are not the underlying applicable requirements). If an emission limit is calculated based on the type of source and design capacity or if a standard is based on a design parameter, this information should also be included.

See Attachment I for applicable requirements, monitoring, recordkeeping, reporting and testing from existing Title V permit.

X Permit Shield

For all applicable requirements listed above, provide monitoring/testing/recordkeeping/reporting which shall be used to demonstrate compliance. If the method is based on a permit or rule, include the condition number or citation. (Note: Each requirement listed above must have an associated method of demonstrating compliance. If there is not already a required method in place, then a method must be proposed.)

See Attachment I for applicable requirements, monitoring, recordkeeping, reporting and testing from existing Title V permit.

Are you in compliance with all applicable requirements for this emission unit? X Yes No

If no, complete the **Schedule of Compliance Form** as **ATTACHMENT F**.

ATTACHMENT E - Emission Unit Form

Emission Unit Description: Storage Tank

Emission unit ID number: 8365	Emission unit name: Tank 8365	List any control devices associated with this emission unit:
---	---	---

Provide a description of the emission unit (type, method of operation, design parameters, etc.):
Storage of volatile organic liquid

Manufacturer:	Model number:	Serial number:
----------------------	----------------------	-----------------------

Construction date: See Attachment D Equipment Table	Installation date: See Attachment D Equipment Table	Modification date(s): See Attachment D Equipment Table
---	---	--

Design Capacity (examples: furnaces - tons/hr, tanks - gallons): See Attachment D Equipment Table

Maximum Hourly Throughput:	Maximum Annual Throughput:	Maximum Operating Schedule: 24 hrs/day, 365 days/yr
-----------------------------------	-----------------------------------	---

Fuel Usage Data (fill out all applicable fields)

Does this emission unit combust fuel? ___ Yes <u> X </u> No	If yes, is it? ___ Indirect Fired ___ Direct Fired
--	--

Maximum design heat input and/or maximum horsepower rating:	Type and Btu/hr rating of burners:
--	---

List the primary fuel type(s) and if applicable, the secondary fuel type(s). For each fuel type listed, provide the maximum hourly and annual fuel usage for each.

Describe each fuel expected to be used during the term of the permit.

Fuel Type	Max. Sulfur Content	Max. Ash Content	BTU Value

Union Carbide Corporation South Charleston Facility – TRITON

Emissions Data		
Criteria Pollutants	Potential Emissions	
	PPH	TPY
Carbon Monoxide (CO)		
Nitrogen Oxides (NO _x)		
Lead (Pb)		
Particulate Matter (PM _{2.5})		
Particulate Matter (PM ₁₀)		
Total Particulate Matter (TSP)		
Sulfur Dioxide (SO ₂)		
Volatile Organic Compounds (VOC)		
Hazardous Air Pollutants	Potential Emissions	
	PPH	TPY
Regulated Pollutants other than Criteria and HAP	Potential Emissions	
	PPH	TPY

List the method(s) used to calculate the potential emissions (include dates of any stack tests conducted, versions of software used, source and dates of emission factors, etc.).

Applicable Requirements

List all applicable requirements for this emission unit. For each applicable requirement, include the underlying rule/regulation citation and/or construction permit with the condition number. (Note: Title V permit condition numbers alone are not the underlying applicable requirements). If an emission limit is calculated based on the type of source and design capacity or if a standard is based on a design parameter, this information should also be included.

See Attachment I for applicable requirements, monitoring, recordkeeping, reporting and testing from existing Title V permit.

Permit Shield

For all applicable requirements listed above, provide monitoring/testing/recordkeeping/reporting which shall be used to demonstrate compliance. If the method is based on a permit or rule, include the condition number or citation. (Note: Each requirement listed above must have an associated method of demonstrating compliance. If there is not already a required method in place, then a method must be proposed.)

See Attachment I for applicable requirements, monitoring, recordkeeping, reporting and testing from existing Title V permit.

Are you in compliance with all applicable requirements for this emission unit? Yes No

If no, complete the **Schedule of Compliance Form** as ATTACHMENT F.

ATTACHMENT E - Emission Unit Form

Emission Unit Description: Storage Tank

Emission unit ID number: 8362	Emission unit name: Tank 8362	List any control devices associated with this emission unit:
---	---	---

Provide a description of the emission unit (type, method of operation, design parameters, etc.):
Storage of volatile organic liquid

Manufacturer:	Model number:	Serial number:
----------------------	----------------------	-----------------------

Construction date: See Attachment D Equipment Table	Installation date: See Attachment D Equipment Table	Modification date(s): See Attachment D Equipment Table
---	---	--

Design Capacity (examples: furnaces - tons/hr, tanks - gallons): See Attachment D Equipment Table

Maximum Hourly Throughput:	Maximum Annual Throughput:	Maximum Operating Schedule: 24 hrs/day, 365 days/yr
-----------------------------------	-----------------------------------	---

Fuel Usage Data (fill out all applicable fields)

Does this emission unit combust fuel? ___Yes <u>X</u> No	If yes, is it? ___ Indirect Fired ___ Direct Fired
---	--

Maximum design heat input and/or maximum horsepower rating:	Type and Btu/hr rating of burners:
--	---

List the primary fuel type(s) and if applicable, the secondary fuel type(s). For each fuel type listed, provide the maximum hourly and annual fuel usage for each.

Describe each fuel expected to be used during the term of the permit.

Fuel Type	Max. Sulfur Content	Max. Ash Content	BTU Value

Union Carbide Corporation South Charleston Facility – TRITON

<i>Emissions Data</i>		
Criteria Pollutants	Potential Emissions	
	PPH	TPY
Carbon Monoxide (CO)		
Nitrogen Oxides (NO _x)		
Lead (Pb)		
Particulate Matter (PM _{2.5})		
Particulate Matter (PM ₁₀)		
Total Particulate Matter (TSP)		
Sulfur Dioxide (SO ₂)		
Volatile Organic Compounds (VOC)		
Hazardous Air Pollutants	Potential Emissions	
	PPH	TPY
Regulated Pollutants other than Criteria and HAP	Potential Emissions	
	PPH	TPY

List the method(s) used to calculate the potential emissions (include dates of any stack tests conducted, versions of software used, source and dates of emission factors, etc.).

Applicable Requirements

List all applicable requirements for this emission unit. For each applicable requirement, include the underlying rule/regulation citation and/or construction permit with the condition number. (Note: Title V permit condition numbers alone are not the underlying applicable requirements). If an emission limit is calculated based on the type of source and design capacity or if a standard is based on a design parameter, this information should also be included.

See Attachment I for applicable requirements, monitoring, recordkeeping, reporting and testing from existing Title V permit.

Permit Shield

For all applicable requirements listed above, provide monitoring/testing/recordkeeping/reporting which shall be used to demonstrate compliance. If the method is based on a permit or rule, include the condition number or citation. (Note: Each requirement listed above must have an associated method of demonstrating compliance. If there is not already a required method in place, then a method must be proposed.)

See Attachment I for applicable requirements, monitoring, recordkeeping, reporting and testing from existing Title V permit.

Are you in compliance with all applicable requirements for this emission unit? Yes No

If no, complete the **Schedule of Compliance Form** as ATTACHMENT F.

ATTACHMENT E - Emission Unit Form

Emission Unit Description: Storage Tank

Emission unit ID number: 8355	Emission unit name: Tank 8355	List any control devices associated with this emission unit:
---	---	---

Provide a description of the emission unit (type, method of operation, design parameters, etc.):
Storage of volatile organic liquid

Manufacturer:	Model number:	Serial number:
----------------------	----------------------	-----------------------

Construction date: See Attachment D Equipment Table	Installation date: See Attachment D Equipment Table	Modification date(s): See Attachment D Equipment Table
---	---	--

Design Capacity (examples: furnaces - tons/hr, tanks - gallons): See Attachment D Equipment Table

Maximum Hourly Throughput:	Maximum Annual Throughput:	Maximum Operating Schedule: 24 hrs/day, 365 days/yr
-----------------------------------	-----------------------------------	---

Fuel Usage Data (fill out all applicable fields)

Does this emission unit combust fuel? ___Yes <u>X</u> No	If yes, is it? ___ Indirect Fired ___ Direct Fired
---	--

Maximum design heat input and/or maximum horsepower rating:	Type and Btu/hr rating of burners:
--	---

List the primary fuel type(s) and if applicable, the secondary fuel type(s). For each fuel type listed, provide the maximum hourly and annual fuel usage for each.

Describe each fuel expected to be used during the term of the permit.

Fuel Type	Max. Sulfur Content	Max. Ash Content	BTU Value

Union Carbide Corporation South Charleston Facility – TRITON

<i>Emissions Data</i>		
Criteria Pollutants	Potential Emissions	
	PPH	TPY
Carbon Monoxide (CO)		
Nitrogen Oxides (NO _x)		
Lead (Pb)		
Particulate Matter (PM _{2.5})		
Particulate Matter (PM ₁₀)		
Total Particulate Matter (TSP)		
Sulfur Dioxide (SO ₂)		
Volatile Organic Compounds (VOC)		
Hazardous Air Pollutants	Potential Emissions	
	PPH	TPY
Regulated Pollutants other than Criteria and HAP	Potential Emissions	
	PPH	TPY

List the method(s) used to calculate the potential emissions (include dates of any stack tests conducted, versions of software used, source and dates of emission factors, etc.).

Applicable Requirements

List all applicable requirements for this emission unit. For each applicable requirement, include the underlying rule/regulation citation and/or construction permit with the condition number. (Note: Title V permit condition numbers alone are not the underlying applicable requirements). If an emission limit is calculated based on the type of source and design capacity or if a standard is based on a design parameter, this information should also be included.

See Attachment I for applicable requirements, monitoring, recordkeeping, reporting and testing from existing Title V permit.

Permit Shield

For all applicable requirements listed above, provide monitoring/testing/recordkeeping/reporting which shall be used to demonstrate compliance. If the method is based on a permit or rule, include the condition number or citation. (Note: Each requirement listed above must have an associated method of demonstrating compliance. If there is not already a required method in place, then a method must be proposed.)

See Attachment I for applicable requirements, monitoring, recordkeeping, reporting and testing from existing Title V permit.

Are you in compliance with all applicable requirements for this emission unit? Yes No

If no, complete the **Schedule of Compliance Form** as ATTACHMENT F.

ATTACHMENT E - Emission Unit Form

Emission Unit Description: Storage Tank			
Emission unit ID number: 8356	Emission unit name: Tank 8356	List any control devices associated with this emission unit:	
Provide a description of the emission unit (type, method of operation, design parameters, etc.): Storage of volatile organic liquid			
Manufacturer:	Model number:	Serial number:	
Construction date: See Attachment D Equipment Table	Installation date: See Attachment D Equipment Table	Modification date(s): See Attachment D Equipment Table	
Design Capacity (examples: furnaces - tons/hr, tanks - gallons): See Attachment D Equipment Table			
Maximum Hourly Throughput:	Maximum Annual Throughput:	Maximum Operating Schedule: 24 hrs/day, 365 days/yr	
Fuel Usage Data (fill out all applicable fields)			
Does this emission unit combust fuel? ___Yes <input checked="" type="checkbox"/> No		If yes, is it? ___ Indirect Fired ___ Direct Fired	
Maximum design heat input and/or maximum horsepower rating:		Type and Btu/hr rating of burners:	
List the primary fuel type(s) and if applicable, the secondary fuel type(s). For each fuel type listed, provide the maximum hourly and annual fuel usage for each.			
Describe each fuel expected to be used during the term of the permit.			
Fuel Type	Max. Sulfur Content	Max. Ash Content	BTU Value

Union Carbide Corporation South Charleston Facility – TRITON

<i>Emissions Data</i>		
Criteria Pollutants	Potential Emissions	
	PPH	TPY
Carbon Monoxide (CO)		
Nitrogen Oxides (NO _x)		
Lead (Pb)		
Particulate Matter (PM _{2.5})		
Particulate Matter (PM ₁₀)		
Total Particulate Matter (TSP)		
Sulfur Dioxide (SO ₂)		
Volatile Organic Compounds (VOC)		
Hazardous Air Pollutants	Potential Emissions	
	PPH	TPY
Regulated Pollutants other than Criteria and HAP	Potential Emissions	
	PPH	TPY

List the method(s) used to calculate the potential emissions (include dates of any stack tests conducted, versions of software used, source and dates of emission factors, etc.).

Applicable Requirements

List all applicable requirements for this emission unit. For each applicable requirement, include the underlying rule/regulation citation and/or construction permit with the condition number. (Note: Title V permit condition numbers alone are not the underlying applicable requirements). If an emission limit is calculated based on the type of source and design capacity or if a standard is based on a design parameter, this information should also be included.

See Attachment I for applicable requirements, monitoring, recordkeeping, reporting and testing from existing Title V permit.

X Permit Shield

For all applicable requirements listed above, provide monitoring/testing/recordkeeping/reporting which shall be used to demonstrate compliance. If the method is based on a permit or rule, include the condition number or citation. (Note: Each requirement listed above must have an associated method of demonstrating compliance. If there is not already a required method in place, then a method must be proposed.)

See Attachment I for applicable requirements, monitoring, recordkeeping, reporting and testing from existing Title V permit.

Are you in compliance with all applicable requirements for this emission unit? X Yes No

If no, complete the **Schedule of Compliance Form** as **ATTACHMENT F**.

ATTACHMENT E - Emission Unit Form

Emission Unit Description: Storage Tank			
Emission unit ID number: 8360	Emission unit name: Tank 8360	List any control devices associated with this emission unit:	
Provide a description of the emission unit (type, method of operation, design parameters, etc.): Storage of volatile organic liquid			
Manufacturer:	Model number:	Serial number:	
Construction date: See Attachment D Equipment Table	Installation date: See Attachment D Equipment Table	Modification date(s): See Attachment D Equipment Table	
Design Capacity (examples: furnaces - tons/hr, tanks - gallons): See Attachment D Equipment Table			
Maximum Hourly Throughput:	Maximum Annual Throughput:	Maximum Operating Schedule: 24 hrs/day, 365 days/yr	
Fuel Usage Data (fill out all applicable fields)			
Does this emission unit combust fuel? ___Yes <input checked="" type="checkbox"/> No		If yes, is it? ___ Indirect Fired ___ Direct Fired	
Maximum design heat input and/or maximum horsepower rating:		Type and Btu/hr rating of burners:	
List the primary fuel type(s) and if applicable, the secondary fuel type(s). For each fuel type listed, provide the maximum hourly and annual fuel usage for each.			
Describe each fuel expected to be used during the term of the permit.			
Fuel Type	Max. Sulfur Content	Max. Ash Content	BTU Value

Union Carbide Corporation South Charleston Facility – TRITON

<i>Emissions Data</i>		
Criteria Pollutants	Potential Emissions	
	PPH	TPY
Carbon Monoxide (CO)		
Nitrogen Oxides (NO _x)		
Lead (Pb)		
Particulate Matter (PM _{2.5})		
Particulate Matter (PM ₁₀)		
Total Particulate Matter (TSP)		
Sulfur Dioxide (SO ₂)		
Volatile Organic Compounds (VOC)		
Hazardous Air Pollutants	Potential Emissions	
	PPH	TPY
Regulated Pollutants other than Criteria and HAP	Potential Emissions	
	PPH	TPY

List the method(s) used to calculate the potential emissions (include dates of any stack tests conducted, versions of software used, source and dates of emission factors, etc.).

Applicable Requirements

List all applicable requirements for this emission unit. For each applicable requirement, include the underlying rule/regulation citation and/or construction permit with the condition number. (Note: Title V permit condition numbers alone are not the underlying applicable requirements). If an emission limit is calculated based on the type of source and design capacity or if a standard is based on a design parameter, this information should also be included.

See Attachment I for applicable requirements, monitoring, recordkeeping, reporting and testing from existing Title V permit.

Permit Shield

For all applicable requirements listed above, provide monitoring/testing/recordkeeping/reporting which shall be used to demonstrate compliance. If the method is based on a permit or rule, include the condition number or citation. (Note: Each requirement listed above must have an associated method of demonstrating compliance. If there is not already a required method in place, then a method must be proposed.)

See Attachment I for applicable requirements, monitoring, recordkeeping, reporting and testing from existing Title V permit.

Are you in compliance with all applicable requirements for this emission unit? Yes No

If no, complete the **Schedule of Compliance Form** as ATTACHMENT F.

ATTACHMENT E - Emission Unit Form

Emission Unit Description: Storage Tank

Emission unit ID number: 8361	Emission unit name: Tank 8361	List any control devices associated with this emission unit:
---	---	---

Provide a description of the emission unit (type, method of operation, design parameters, etc.):
Storage of volatile organic liquid

Manufacturer:	Model number:	Serial number:
----------------------	----------------------	-----------------------

Construction date: See Attachment D Equipment Table	Installation date: See Attachment D Equipment Table	Modification date(s): See Attachment D Equipment Table
---	---	--

Design Capacity (examples: furnaces - tons/hr, tanks - gallons): See Attachment D Equipment Table

Maximum Hourly Throughput:	Maximum Annual Throughput:	Maximum Operating Schedule: 24 hrs/day, 365 days/yr
-----------------------------------	-----------------------------------	---

Fuel Usage Data (fill out all applicable fields)

Does this emission unit combust fuel? ___Yes <u>X</u> No	If yes, is it? ___ Indirect Fired ___ Direct Fired
---	--

Maximum design heat input and/or maximum horsepower rating:	Type and Btu/hr rating of burners:
--	---

List the primary fuel type(s) and if applicable, the secondary fuel type(s). For each fuel type listed, provide the maximum hourly and annual fuel usage for each.

Describe each fuel expected to be used during the term of the permit.

Fuel Type	Max. Sulfur Content	Max. Ash Content	BTU Value

Union Carbide Corporation South Charleston Facility – TRITON

<i>Emissions Data</i>		
Criteria Pollutants	Potential Emissions	
	PPH	TPY
Carbon Monoxide (CO)		
Nitrogen Oxides (NO _x)		
Lead (Pb)		
Particulate Matter (PM _{2.5})		
Particulate Matter (PM ₁₀)		
Total Particulate Matter (TSP)		
Sulfur Dioxide (SO ₂)		
Volatile Organic Compounds (VOC)		
Hazardous Air Pollutants	Potential Emissions	
	PPH	TPY
Regulated Pollutants other than Criteria and HAP	Potential Emissions	
	PPH	TPY

List the method(s) used to calculate the potential emissions (include dates of any stack tests conducted, versions of software used, source and dates of emission factors, etc.).

Applicable Requirements

List all applicable requirements for this emission unit. For each applicable requirement, include the underlying rule/regulation citation and/or construction permit with the condition number. (Note: Title V permit condition numbers alone are not the underlying applicable requirements). If an emission limit is calculated based on the type of source and design capacity or if a standard is based on a design parameter, this information should also be included.

See Attachment I for applicable requirements, monitoring, recordkeeping, reporting and testing from existing Title V permit.

 X Permit Shield

For all applicable requirements listed above, provide monitoring/testing/recordkeeping/reporting which shall be used to demonstrate compliance. If the method is based on a permit or rule, include the condition number or citation. (Note: Each requirement listed above must have an associated method of demonstrating compliance. If there is not already a required method in place, then a method must be proposed.)

See Attachment I for applicable requirements, monitoring, recordkeeping, reporting and testing from existing Title V permit.

Are you in compliance with all applicable requirements for this emission unit? X Yes No

If no, complete the **Schedule of Compliance Form** as **ATTACHMENT F**.

ATTACHMENT E - Emission Unit Form

Emission Unit Description: Storage Tank

Emission unit ID number: 8353	Emission unit name: Tank 8353	List any control devices associated with this emission unit: C8130
---	---	--

Provide a description of the emission unit (type, method of operation, design parameters, etc.):
Storage of volatile organic liquid

Manufacturer:	Model number:	Serial number:
----------------------	----------------------	-----------------------

Construction date: See Attachment D Equipment Table	Installation date: See Attachment D Equipment Table	Modification date(s): See Attachment D Equipment Table
---	---	--

Design Capacity (examples: furnaces - tons/hr, tanks - gallons): See Attachment D Equipment Table

Maximum Hourly Throughput:	Maximum Annual Throughput:	Maximum Operating Schedule: 24 hrs/day, 365 days/yr
-----------------------------------	-----------------------------------	---

Fuel Usage Data (fill out all applicable fields)

Does this emission unit combust fuel? ___Yes <u>X</u> No	If yes, is it? ___ Indirect Fired ___ Direct Fired
---	--

Maximum design heat input and/or maximum horsepower rating:	Type and Btu/hr rating of burners:
--	---

List the primary fuel type(s) and if applicable, the secondary fuel type(s). For each fuel type listed, provide the maximum hourly and annual fuel usage for each.

Describe each fuel expected to be used during the term of the permit.

Fuel Type	Max. Sulfur Content	Max. Ash Content	BTU Value

Union Carbide Corporation South Charleston Facility – TRITON

<i>Emissions Data</i>		
Criteria Pollutants	Potential Emissions	
	PPH	TPY
Carbon Monoxide (CO)		
Nitrogen Oxides (NO _x)		
Lead (Pb)		
Particulate Matter (PM _{2.5})		
Particulate Matter (PM ₁₀)		
Total Particulate Matter (TSP)		
Sulfur Dioxide (SO ₂)		
Volatile Organic Compounds (VOC)		
Hazardous Air Pollutants	Potential Emissions	
	PPH	TPY
Regulated Pollutants other than Criteria and HAP	Potential Emissions	
	PPH	TPY

List the method(s) used to calculate the potential emissions (include dates of any stack tests conducted, versions of software used, source and dates of emission factors, etc.).

Applicable Requirements

List all applicable requirements for this emission unit. For each applicable requirement, include the underlying rule/regulation citation and/or construction permit with the condition number. (Note: Title V permit condition numbers alone are not the underlying applicable requirements). If an emission limit is calculated based on the type of source and design capacity or if a standard is based on a design parameter, this information should also be included.

See Attachment I for applicable requirements, monitoring, recordkeeping, reporting and testing from existing Title V permit.

X Permit Shield

For all applicable requirements listed above, provide monitoring/testing/recordkeeping/reporting which shall be used to demonstrate compliance. If the method is based on a permit or rule, include the condition number or citation. (Note: Each requirement listed above must have an associated method of demonstrating compliance. If there is not already a required method in place, then a method must be proposed.)

See Attachment I for applicable requirements, monitoring, recordkeeping, reporting and testing from existing Title V permit.

Are you in compliance with all applicable requirements for this emission unit? X Yes No

If no, complete the **Schedule of Compliance Form** as **ATTACHMENT F**.

ATTACHMENT E - Emission Unit Form

Emission Unit Description: Storage Tank

Emission unit ID number: 8354	Emission unit name: Tank 8354	List any control devices associated with this emission unit:
---	---	---

Provide a description of the emission unit (type, method of operation, design parameters, etc.):

Storage of volatile organic liquid

Manufacturer:	Model number:	Serial number:
Construction date: See Attachment D Equipment Table	Installation date: See Attachment D Equipment Table	Modification date(s): See Attachment D Equipment Table

Design Capacity (examples: furnaces - tons/hr, tanks - gallons): See Attachment D Equipment Table

Maximum Hourly Throughput:	Maximum Annual Throughput:	Maximum Operating Schedule: 24 hrs/day, 365 days/yr
-----------------------------------	-----------------------------------	---

Fuel Usage Data (fill out all applicable fields)

Does this emission unit combust fuel? ___ Yes <u> X </u> No	If yes, is it? ___ Indirect Fired ___ Direct Fired
Maximum design heat input and/or maximum horsepower rating:	Type and Btu/hr rating of burners:

List the primary fuel type(s) and if applicable, the secondary fuel type(s). For each fuel type listed, provide the maximum hourly and annual fuel usage for each.

Describe each fuel expected to be used during the term of the permit.

Fuel Type	Max. Sulfur Content	Max. Ash Content	BTU Value

Union Carbide Corporation South Charleston Facility – TRITON

<i>Emissions Data</i>		
Criteria Pollutants	Potential Emissions	
	PPH	TPY
Carbon Monoxide (CO)		
Nitrogen Oxides (NO _x)		
Lead (Pb)		
Particulate Matter (PM _{2.5})		
Particulate Matter (PM ₁₀)		
Total Particulate Matter (TSP)		
Sulfur Dioxide (SO ₂)		
Volatile Organic Compounds (VOC)		
Hazardous Air Pollutants	Potential Emissions	
	PPH	TPY
Regulated Pollutants other than Criteria and HAP	Potential Emissions	
	PPH	TPY

List the method(s) used to calculate the potential emissions (include dates of any stack tests conducted, versions of software used, source and dates of emission factors, etc.).

Applicable Requirements

List all applicable requirements for this emission unit. For each applicable requirement, include the underlying rule/regulation citation and/or construction permit with the condition number. (Note: Title V permit condition numbers alone are not the underlying applicable requirements). If an emission limit is calculated based on the type of source and design capacity or if a standard is based on a design parameter, this information should also be included.

See Attachment I for applicable requirements, monitoring, recordkeeping, reporting and testing from existing Title V permit.

X Permit Shield

For all applicable requirements listed above, provide monitoring/testing/recordkeeping/reporting which shall be used to demonstrate compliance. If the method is based on a permit or rule, include the condition number or citation. (Note: Each requirement listed above must have an associated method of demonstrating compliance. If there is not already a required method in place, then a method must be proposed.)

See Attachment I for applicable requirements, monitoring, recordkeeping, reporting and testing from existing Title V permit.

Are you in compliance with all applicable requirements for this emission unit? X Yes No

If no, complete the **Schedule of Compliance Form** as **ATTACHMENT F**.

ATTACHMENT E - Emission Unit Form

Emission Unit Description: Storage Tank			
Emission unit ID number: 8350	Emission unit name: Tank 8350	List any control devices associated with this emission unit:	
Provide a description of the emission unit (type, method of operation, design parameters, etc.): Storage of volatile organic liquid			
Manufacturer:	Model number:	Serial number:	
Construction date: See Attachment D Equipment Table	Installation date: See Attachment D Equipment Table	Modification date(s): See Attachment D Equipment Table	
Design Capacity (examples: furnaces - tons/hr, tanks - gallons): See Attachment D Equipment Table			
Maximum Hourly Throughput:	Maximum Annual Throughput:	Maximum Operating Schedule: 24 hrs/day, 365 days/yr	
Fuel Usage Data (fill out all applicable fields)			
Does this emission unit combust fuel? ___Yes <input checked="" type="checkbox"/> No		If yes, is it? ___ Indirect Fired ___ Direct Fired	
Maximum design heat input and/or maximum horsepower rating:		Type and Btu/hr rating of burners:	
List the primary fuel type(s) and if applicable, the secondary fuel type(s). For each fuel type listed, provide the maximum hourly and annual fuel usage for each.			
Describe each fuel expected to be used during the term of the permit.			
Fuel Type	Max. Sulfur Content	Max. Ash Content	BTU Value

Union Carbide Corporation South Charleston Facility – TRITON

<i>Emissions Data</i>		
Criteria Pollutants	Potential Emissions	
	PPH	TPY
Carbon Monoxide (CO)		
Nitrogen Oxides (NO _x)		
Lead (Pb)		
Particulate Matter (PM _{2.5})		
Particulate Matter (PM ₁₀)		
Total Particulate Matter (TSP)		
Sulfur Dioxide (SO ₂)		
Volatile Organic Compounds (VOC)		
Hazardous Air Pollutants	Potential Emissions	
	PPH	TPY
Regulated Pollutants other than Criteria and HAP	Potential Emissions	
	PPH	TPY

List the method(s) used to calculate the potential emissions (include dates of any stack tests conducted, versions of software used, source and dates of emission factors, etc.).

Applicable Requirements

List all applicable requirements for this emission unit. For each applicable requirement, include the underlying rule/regulation citation and/or construction permit with the condition number. (Note: Title V permit condition numbers alone are not the underlying applicable requirements). If an emission limit is calculated based on the type of source and design capacity or if a standard is based on a design parameter, this information should also be included.

See Attachment I for applicable requirements, monitoring, recordkeeping, reporting and testing from existing Title V permit.

Permit Shield

For all applicable requirements listed above, provide monitoring/testing/recordkeeping/reporting which shall be used to demonstrate compliance. If the method is based on a permit or rule, include the condition number or citation. (Note: Each requirement listed above must have an associated method of demonstrating compliance. If there is not already a required method in place, then a method must be proposed.)

See Attachment I for applicable requirements, monitoring, recordkeeping, reporting and testing from existing Title V permit.

Are you in compliance with all applicable requirements for this emission unit? Yes No

If no, complete the **Schedule of Compliance Form** as ATTACHMENT F.

ATTACHMENT E - Emission Unit Form

Emission Unit Description: Storage Tank			
Emission unit ID number: 8352	Emission unit name: Tank 8352	List any control devices associated with this emission unit:	
Provide a description of the emission unit (type, method of operation, design parameters, etc.): Storage of volatile organic liquid			
Manufacturer:	Model number:	Serial number:	
Construction date: See Attachment D Equipment Table	Installation date: See Attachment D Equipment Table	Modification date(s): See Attachment D Equipment Table	
Design Capacity (examples: furnaces - tons/hr, tanks - gallons): See Attachment D Equipment Table			
Maximum Hourly Throughput:	Maximum Annual Throughput:	Maximum Operating Schedule: 24 hrs/day, 365 days/yr	
Fuel Usage Data (fill out all applicable fields)			
Does this emission unit combust fuel? ___Yes <u>X</u> No		If yes, is it? ___ Indirect Fired ___ Direct Fired	
Maximum design heat input and/or maximum horsepower rating:		Type and Btu/hr rating of burners:	
List the primary fuel type(s) and if applicable, the secondary fuel type(s). For each fuel type listed, provide the maximum hourly and annual fuel usage for each.			
Describe each fuel expected to be used during the term of the permit.			
Fuel Type	Max. Sulfur Content	Max. Ash Content	BTU Value

Union Carbide Corporation South Charleston Facility – TRITON

<i>Emissions Data</i>		
Criteria Pollutants	Potential Emissions	
	PPH	TPY
Carbon Monoxide (CO)		
Nitrogen Oxides (NO _x)		
Lead (Pb)		
Particulate Matter (PM _{2.5})		
Particulate Matter (PM ₁₀)		
Total Particulate Matter (TSP)		
Sulfur Dioxide (SO ₂)		
Volatile Organic Compounds (VOC)		
Hazardous Air Pollutants	Potential Emissions	
	PPH	TPY
Regulated Pollutants other than Criteria and HAP	Potential Emissions	
	PPH	TPY

List the method(s) used to calculate the potential emissions (include dates of any stack tests conducted, versions of software used, source and dates of emission factors, etc.).

Applicable Requirements

List all applicable requirements for this emission unit. For each applicable requirement, include the underlying rule/regulation citation and/or construction permit with the condition number. (Note: Title V permit condition numbers alone are not the underlying applicable requirements). If an emission limit is calculated based on the type of source and design capacity or if a standard is based on a design parameter, this information should also be included.

See Attachment I for applicable requirements, monitoring, recordkeeping, reporting and testing from existing Title V permit.

X Permit Shield

For all applicable requirements listed above, provide monitoring/testing/recordkeeping/reporting which shall be used to demonstrate compliance. If the method is based on a permit or rule, include the condition number or citation. (Note: Each requirement listed above must have an associated method of demonstrating compliance. If there is not already a required method in place, then a method must be proposed.)

See Attachment I for applicable requirements, monitoring, recordkeeping, reporting and testing from existing Title V permit.

Are you in compliance with all applicable requirements for this emission unit? X Yes No

If no, complete the **Schedule of Compliance Form** as **ATTACHMENT F**.

ATTACHMENT E - Emission Unit Form

Emission Unit Description: Storage Tank			
Emission unit ID number: 8351	Emission unit name: Tank 8351	List any control devices associated with this emission unit:	
Provide a description of the emission unit (type, method of operation, design parameters, etc.): Storage of volatile organic liquid			
Manufacturer:	Model number:	Serial number:	
Construction date: See Attachment D Equipment Table	Installation date: See Attachment D Equipment Table	Modification date(s): See Attachment D Equipment Table	
Design Capacity (examples: furnaces - tons/hr, tanks - gallons): See Attachment D Equipment Table			
Maximum Hourly Throughput:	Maximum Annual Throughput:	Maximum Operating Schedule: 24 hrs/day, 365 days/yr	
Fuel Usage Data (fill out all applicable fields)			
Does this emission unit combust fuel? ___Yes <input checked="" type="checkbox"/> No		If yes, is it? ___ Indirect Fired ___ Direct Fired	
Maximum design heat input and/or maximum horsepower rating:		Type and Btu/hr rating of burners:	
List the primary fuel type(s) and if applicable, the secondary fuel type(s). For each fuel type listed, provide the maximum hourly and annual fuel usage for each.			
Describe each fuel expected to be used during the term of the permit.			
Fuel Type	Max. Sulfur Content	Max. Ash Content	BTU Value

Union Carbide Corporation South Charleston Facility – TRITON

<i>Emissions Data</i>		
Criteria Pollutants	Potential Emissions	
	PPH	TPY
Carbon Monoxide (CO)		
Nitrogen Oxides (NO _x)		
Lead (Pb)		
Particulate Matter (PM _{2.5})		
Particulate Matter (PM ₁₀)		
Total Particulate Matter (TSP)		
Sulfur Dioxide (SO ₂)		
Volatile Organic Compounds (VOC)		
Hazardous Air Pollutants	Potential Emissions	
	PPH	TPY
Regulated Pollutants other than Criteria and HAP	Potential Emissions	
	PPH	TPY

List the method(s) used to calculate the potential emissions (include dates of any stack tests conducted, versions of software used, source and dates of emission factors, etc.).

Applicable Requirements

List all applicable requirements for this emission unit. For each applicable requirement, include the underlying rule/regulation citation and/or construction permit with the condition number. (Note: Title V permit condition numbers alone are not the underlying applicable requirements). If an emission limit is calculated based on the type of source and design capacity or if a standard is based on a design parameter, this information should also be included.

See Attachment I for applicable requirements, monitoring, recordkeeping, reporting and testing from existing Title V permit.

X Permit Shield

For all applicable requirements listed above, provide monitoring/testing/recordkeeping/reporting which shall be used to demonstrate compliance. If the method is based on a permit or rule, include the condition number or citation. (Note: Each requirement listed above must have an associated method of demonstrating compliance. If there is not already a required method in place, then a method must be proposed.)

See Attachment I for applicable requirements, monitoring, recordkeeping, reporting and testing from existing Title V permit.

Are you in compliance with all applicable requirements for this emission unit? X Yes No

If no, complete the **Schedule of Compliance Form** as **ATTACHMENT F**.

ATTACHMENT E - Emission Unit Form

Emission Unit Description: Storage Tank

Emission unit ID number: 8346	Emission unit name: Tank 8346	List any control devices associated with this emission unit:
---	---	---

Provide a description of the emission unit (type, method of operation, design parameters, etc.):

Storage of volatile organic liquid

Manufacturer:	Model number:	Serial number:
Construction date: See Attachment D Equipment Table	Installation date: See Attachment D Equipment Table	Modification date(s): See Attachment D Equipment Table

Design Capacity (examples: furnaces - tons/hr, tanks - gallons): See Attachment D Equipment Table

Maximum Hourly Throughput:	Maximum Annual Throughput:	Maximum Operating Schedule: 24 hrs/day, 365 days/yr
-----------------------------------	-----------------------------------	---

Fuel Usage Data (fill out all applicable fields)

Does this emission unit combust fuel? ___Yes <u>X</u> No	If yes, is it? ___ Indirect Fired ___ Direct Fired
Maximum design heat input and/or maximum horsepower rating:	Type and Btu/hr rating of burners:

List the primary fuel type(s) and if applicable, the secondary fuel type(s). For each fuel type listed, provide the maximum hourly and annual fuel usage for each.

Describe each fuel expected to be used during the term of the permit.

Fuel Type	Max. Sulfur Content	Max. Ash Content	BTU Value

Union Carbide Corporation South Charleston Facility – TRITON

<i>Emissions Data</i>		
Criteria Pollutants	Potential Emissions	
	PPH	TPY
Carbon Monoxide (CO)		
Nitrogen Oxides (NO _x)		
Lead (Pb)		
Particulate Matter (PM _{2.5})		
Particulate Matter (PM ₁₀)		
Total Particulate Matter (TSP)		
Sulfur Dioxide (SO ₂)		
Volatile Organic Compounds (VOC)		
Hazardous Air Pollutants	Potential Emissions	
	PPH	TPY
Regulated Pollutants other than Criteria and HAP	Potential Emissions	
	PPH	TPY

List the method(s) used to calculate the potential emissions (include dates of any stack tests conducted, versions of software used, source and dates of emission factors, etc.).

Applicable Requirements

List all applicable requirements for this emission unit. For each applicable requirement, include the underlying rule/regulation citation and/or construction permit with the condition number. (Note: Title V permit condition numbers alone are not the underlying applicable requirements). If an emission limit is calculated based on the type of source and design capacity or if a standard is based on a design parameter, this information should also be included.

See Attachment I for applicable requirements, monitoring, recordkeeping, reporting and testing from existing Title V permit.

Permit Shield

For all applicable requirements listed above, provide monitoring/testing/recordkeeping/reporting which shall be used to demonstrate compliance. If the method is based on a permit or rule, include the condition number or citation. (Note: Each requirement listed above must have an associated method of demonstrating compliance. If there is not already a required method in place, then a method must be proposed.)

See Attachment I for applicable requirements, monitoring, recordkeeping, reporting and testing from existing Title V permit.

Are you in compliance with all applicable requirements for this emission unit? Yes No

If no, complete the **Schedule of Compliance Form** as ATTACHMENT F.

ATTACHMENT E - Emission Unit Form

Emission Unit Description: Storage Tank

Emission unit ID number: 8345	Emission unit name: Tank 8345	List any control devices associated with this emission unit:
---	---	---

Provide a description of the emission unit (type, method of operation, design parameters, etc.):

Storage of volatile organic liquid

Manufacturer:	Model number:	Serial number:
Construction date: See Attachment D Equipment Table	Installation date: See Attachment D Equipment Table	Modification date(s): See Attachment D Equipment Table

Design Capacity (examples: furnaces - tons/hr, tanks - gallons): See Attachment D Equipment Table

Maximum Hourly Throughput:	Maximum Annual Throughput:	Maximum Operating Schedule: 24 hrs/day, 365 days/yr
-----------------------------------	-----------------------------------	---

Fuel Usage Data (fill out all applicable fields)

Does this emission unit combust fuel? ___Yes <u>X</u> No	If yes, is it? ___ Indirect Fired ___ Direct Fired
Maximum design heat input and/or maximum horsepower rating:	Type and Btu/hr rating of burners:

List the primary fuel type(s) and if applicable, the secondary fuel type(s). For each fuel type listed, provide the maximum hourly and annual fuel usage for each.

Describe each fuel expected to be used during the term of the permit.

Fuel Type	Max. Sulfur Content	Max. Ash Content	BTU Value

Union Carbide Corporation South Charleston Facility – TRITON

<i>Emissions Data</i>		
Criteria Pollutants	Potential Emissions	
	PPH	TPY
Carbon Monoxide (CO)		
Nitrogen Oxides (NO _x)		
Lead (Pb)		
Particulate Matter (PM _{2.5})		
Particulate Matter (PM ₁₀)		
Total Particulate Matter (TSP)		
Sulfur Dioxide (SO ₂)		
Volatile Organic Compounds (VOC)		
Hazardous Air Pollutants	Potential Emissions	
	PPH	TPY
Regulated Pollutants other than Criteria and HAP	Potential Emissions	
	PPH	TPY

List the method(s) used to calculate the potential emissions (include dates of any stack tests conducted, versions of software used, source and dates of emission factors, etc.).

Applicable Requirements

List all applicable requirements for this emission unit. For each applicable requirement, include the underlying rule/regulation citation and/or construction permit with the condition number. (Note: Title V permit condition numbers alone are not the underlying applicable requirements). If an emission limit is calculated based on the type of source and design capacity or if a standard is based on a design parameter, this information should also be included.

See Attachment I for applicable requirements, monitoring, recordkeeping, reporting and testing from existing Title V permit.

X Permit Shield

For all applicable requirements listed above, provide monitoring/testing/recordkeeping/reporting which shall be used to demonstrate compliance. If the method is based on a permit or rule, include the condition number or citation. (Note: Each requirement listed above must have an associated method of demonstrating compliance. If there is not already a required method in place, then a method must be proposed.)

See Attachment I for applicable requirements, monitoring, recordkeeping, reporting and testing from existing Title V permit.

Are you in compliance with all applicable requirements for this emission unit? X Yes No

If no, complete the **Schedule of Compliance Form** as **ATTACHMENT F**.

ATTACHMENT E - Emission Unit Form

Emission Unit Description: Storage Tank

Emission unit ID number: 8341	Emission unit name: Tank 8341	List any control devices associated with this emission unit:
---	---	---

Provide a description of the emission unit (type, method of operation, design parameters, etc.):
Storage of volatile organic liquid

Manufacturer:	Model number:	Serial number:
----------------------	----------------------	-----------------------

Construction date: See Attachment D Equipment Table	Installation date: See Attachment D Equipment Table	Modification date(s): See Attachment D Equipment Table
---	---	--

Design Capacity (examples: furnaces - tons/hr, tanks - gallons): See Attachment D Equipment Table

Maximum Hourly Throughput:	Maximum Annual Throughput:	Maximum Operating Schedule: 24 hrs/day, 365 days/yr
-----------------------------------	-----------------------------------	---

Fuel Usage Data (fill out all applicable fields)

Does this emission unit combust fuel? ___Yes <u>X</u> No	If yes, is it? ___ Indirect Fired ___ Direct Fired
---	--

Maximum design heat input and/or maximum horsepower rating:	Type and Btu/hr rating of burners:
--	---

List the primary fuel type(s) and if applicable, the secondary fuel type(s). For each fuel type listed, provide the maximum hourly and annual fuel usage for each.

Describe each fuel expected to be used during the term of the permit.

Fuel Type	Max. Sulfur Content	Max. Ash Content	BTU Value

Union Carbide Corporation South Charleston Facility – TRITON

<i>Emissions Data</i>		
Criteria Pollutants	Potential Emissions	
	PPH	TPY
Carbon Monoxide (CO)		
Nitrogen Oxides (NO _x)		
Lead (Pb)		
Particulate Matter (PM _{2.5})		
Particulate Matter (PM ₁₀)		
Total Particulate Matter (TSP)		
Sulfur Dioxide (SO ₂)		
Volatile Organic Compounds (VOC)		
Hazardous Air Pollutants	Potential Emissions	
	PPH	TPY
Regulated Pollutants other than Criteria and HAP	Potential Emissions	
	PPH	TPY

List the method(s) used to calculate the potential emissions (include dates of any stack tests conducted, versions of software used, source and dates of emission factors, etc.).

Applicable Requirements

List all applicable requirements for this emission unit. For each applicable requirement, include the underlying rule/regulation citation and/or construction permit with the condition number. (Note: Title V permit condition numbers alone are not the underlying applicable requirements). If an emission limit is calculated based on the type of source and design capacity or if a standard is based on a design parameter, this information should also be included.

See Attachment I for applicable requirements, monitoring, recordkeeping, reporting and testing from existing Title V permit.

X Permit Shield

For all applicable requirements listed above, provide monitoring/testing/recordkeeping/reporting which shall be used to demonstrate compliance. If the method is based on a permit or rule, include the condition number or citation. (Note: Each requirement listed above must have an associated method of demonstrating compliance. If there is not already a required method in place, then a method must be proposed.)

See Attachment I for applicable requirements, monitoring, recordkeeping, reporting and testing from existing Title V permit.

Are you in compliance with all applicable requirements for this emission unit? X Yes No

If no, complete the **Schedule of Compliance Form** as **ATTACHMENT F**.

ATTACHMENT E - Emission Unit Form

Emission Unit Description: Storage Tank

Emission unit ID number: 8344	Emission unit name: Tank 8344	List any control devices associated with this emission unit:
---	---	---

Provide a description of the emission unit (type, method of operation, design parameters, etc.):

Storage of volatile organic liquid

Manufacturer:	Model number:	Serial number:
Construction date: See Attachment D Equipment Table	Installation date: See Attachment D Equipment Table	Modification date(s): See Attachment D Equipment Table

Design Capacity (examples: furnaces - tons/hr, tanks - gallons): See Attachment D Equipment Table

Maximum Hourly Throughput:	Maximum Annual Throughput:	Maximum Operating Schedule: 24 hrs/day, 365 days/yr
-----------------------------------	-----------------------------------	---

Fuel Usage Data (fill out all applicable fields)

Does this emission unit combust fuel? ___Yes <u>X</u> No	If yes, is it? ___ Indirect Fired ___ Direct Fired
Maximum design heat input and/or maximum horsepower rating:	Type and Btu/hr rating of burners:

List the primary fuel type(s) and if applicable, the secondary fuel type(s). For each fuel type listed, provide the maximum hourly and annual fuel usage for each.

Describe each fuel expected to be used during the term of the permit.

Fuel Type	Max. Sulfur Content	Max. Ash Content	BTU Value

Union Carbide Corporation South Charleston Facility – TRITON

<i>Emissions Data</i>		
Criteria Pollutants	Potential Emissions	
	PPH	TPY
Carbon Monoxide (CO)		
Nitrogen Oxides (NO _x)		
Lead (Pb)		
Particulate Matter (PM _{2.5})		
Particulate Matter (PM ₁₀)		
Total Particulate Matter (TSP)		
Sulfur Dioxide (SO ₂)		
Volatile Organic Compounds (VOC)		
Hazardous Air Pollutants	Potential Emissions	
	PPH	TPY
Regulated Pollutants other than Criteria and HAP	Potential Emissions	
	PPH	TPY

List the method(s) used to calculate the potential emissions (include dates of any stack tests conducted, versions of software used, source and dates of emission factors, etc.).

Applicable Requirements

List all applicable requirements for this emission unit. For each applicable requirement, include the underlying rule/regulation citation and/or construction permit with the condition number. (Note: Title V permit condition numbers alone are not the underlying applicable requirements). If an emission limit is calculated based on the type of source and design capacity or if a standard is based on a design parameter, this information should also be included.

See Attachment I for applicable requirements, monitoring, recordkeeping, reporting and testing from existing Title V permit.

X Permit Shield

For all applicable requirements listed above, provide monitoring/testing/recordkeeping/reporting which shall be used to demonstrate compliance. If the method is based on a permit or rule, include the condition number or citation. (Note: Each requirement listed above must have an associated method of demonstrating compliance. If there is not already a required method in place, then a method must be proposed.)

See Attachment I for applicable requirements, monitoring, recordkeeping, reporting and testing from existing Title V permit.

Are you in compliance with all applicable requirements for this emission unit? X Yes No

If no, complete the **Schedule of Compliance Form** as **ATTACHMENT F**.

Attachment G

Control Device Sheets

ATTACHMENT G - Air Pollution Control Device Form

Control device ID number: C709	List all emission units associated with this control device. 721T – Product treatment for Vacuum Jet
--	--

Manufacturer:	Model number:	Installation date:
----------------------	----------------------	---------------------------

Type of Air Pollution Control Device:

<input type="checkbox"/> Baghouse/Fabric Filter	<input type="checkbox"/> Venturi Scrubber	<input type="checkbox"/> Multiclone
<input type="checkbox"/> Carbon Bed Adsorber	<input type="checkbox"/> Packed Tower Scrubber	<input type="checkbox"/> Single Cyclone
<input type="checkbox"/> Carbon Drum(s)	<input type="checkbox"/> Other Wet Scrubber	<input type="checkbox"/> Cyclone Bank
<input type="checkbox"/> Catalytic Incinerator	<input checked="" type="checkbox"/> Condenser	<input type="checkbox"/> Settling Chamber
<input type="checkbox"/> Thermal Incinerator	<input type="checkbox"/> Flare	<input type="checkbox"/> Other (describe) _____
<input type="checkbox"/> Wet Plate Electrostatic Precipitator	<input type="checkbox"/> Dry Plate Electrostatic Precipitator	

List the pollutants for which this device is intended to control and the capture and control efficiencies.

Pollutant	Capture Efficiency	Control Efficiency

Explain the characteristic design parameters of this control device (flow rates, pressure drops, number of bags, size, temperatures, etc.).

Operating Parameters:

Is this device subject to the CAM requirements of 40 C.F.R. 64? Yes No

If Yes, **Complete ATTACHMENT H**

If No, **Provide justification.**

Describe the parameters monitored and/or methods used to indicate performance of this control device.

ATTACHMENT G - Air Pollution Control Device Form

Control device ID number: C710 (#2 Jets/Condenser)	List all emission units associated with this control device. 722T – #2 Product treatment for Vacuum Jet
---	---

Manufacturer:	Model number:	Installation date:
----------------------	----------------------	---------------------------

Type of Air Pollution Control Device:

<input type="checkbox"/> Baghouse/Fabric Filter	<input type="checkbox"/> Venturi Scrubber	<input type="checkbox"/> Multiclone
<input type="checkbox"/> Carbon Bed Adsorber	<input type="checkbox"/> Packed Tower Scrubber	<input type="checkbox"/> Single Cyclone
<input type="checkbox"/> Carbon Drum(s)	<input type="checkbox"/> Other Wet Scrubber	<input type="checkbox"/> Cyclone Bank
<input type="checkbox"/> Catalytic Incinerator	<input checked="" type="checkbox"/> Condenser	<input type="checkbox"/> Settling Chamber
<input type="checkbox"/> Thermal Incinerator	<input type="checkbox"/> Flare	<input type="checkbox"/> Other (describe) _____
<input type="checkbox"/> Wet Plate Electrostatic Precipitator	<input type="checkbox"/> Dry Plate Electrostatic Precipitator	

List the pollutants for which this device is intended to control and the capture and control efficiencies.

Pollutant	Capture Efficiency	Control Efficiency

Explain the characteristic design parameters of this control device (flow rates, pressure drops, number of bags, size, temperatures, etc.).

Operating Parameters:

Is this device subject to the CAM requirements of 40 C.F.R. 64? Yes No

If Yes, **Complete ATTACHMENT H**

If No, **Provide justification.**

Describe the parameters monitored and/or methods used to indicate performance of this control device.

ATTACHMENT G - Air Pollution Control Device Form

Control device ID number: C711 (#3 Jets/Condenser)	List all emission units associated with this control device. 723T – #3 Product treatment for Vacuum Jet
---	---

Manufacturer:	Model number:	Installation date:
----------------------	----------------------	---------------------------

Type of Air Pollution Control Device:

<input type="checkbox"/> Baghouse/Fabric Filter	<input type="checkbox"/> Venturi Scrubber	<input type="checkbox"/> Multiclone
<input type="checkbox"/> Carbon Bed Adsorber	<input type="checkbox"/> Packed Tower Scrubber	<input type="checkbox"/> Single Cyclone
<input type="checkbox"/> Carbon Drum(s)	<input type="checkbox"/> Other Wet Scrubber	<input type="checkbox"/> Cyclone Bank
<input type="checkbox"/> Catalytic Incinerator	<input checked="" type="checkbox"/> Condenser	<input type="checkbox"/> Settling Chamber
<input type="checkbox"/> Thermal Incinerator	<input type="checkbox"/> Flare	<input type="checkbox"/> Other (describe) _____
<input type="checkbox"/> Wet Plate Electrostatic Precipitator		<input type="checkbox"/> Dry Plate Electrostatic Precipitator

List the pollutants for which this device is intended to control and the capture and control efficiencies.

Pollutant	Capture Efficiency	Control Efficiency

Explain the characteristic design parameters of this control device (flow rates, pressure drops, number of bags, size, temperatures, etc.).

Operating Parameters:

Is this device subject to the CAM requirements of 40 C.F.R. 64? Yes No

If Yes, **Complete ATTACHMENT H**

If No, **Provide justification.**

Describe the parameters monitored and/or methods used to indicate performance of this control device.

ATTACHMENT G - Air Pollution Control Device Form																				
Control device ID number: A42INC	List all emission units associated with this control device. A42VE																			
Manufacturer: Anguil Environmental Systems, Inc.	Model number: Model 25	Installation date: July 2011																		
Type of Air Pollution Control Device:																				
<table style="width: 100%; border: none;"> <tr> <td style="width: 50%; border: none;"><input type="checkbox"/> Baghouse/Fabric Filter</td> <td style="width: 50%; border: none;"><input type="checkbox"/> Venturi Scrubber</td> </tr> <tr> <td style="border: none;"><input type="checkbox"/> Multiclone</td> <td style="border: none;"><input type="checkbox"/> Packed Tower Scrubber</td> </tr> <tr> <td style="border: none;"><input type="checkbox"/> Carbon Bed Adsorber</td> <td style="border: none;"><input type="checkbox"/> Single Cyclone</td> </tr> <tr> <td style="border: none;"><input type="checkbox"/> Carbon Drum(s)</td> <td style="border: none;"><input type="checkbox"/> Cyclone Bank</td> </tr> <tr> <td style="border: none;"><input type="checkbox"/> Other Wet Scrubber</td> <td style="border: none;"><input type="checkbox"/> Condenser</td> </tr> <tr> <td style="border: none;"><input type="checkbox"/> Catalytic Incinerator</td> <td style="border: none;"><input type="checkbox"/> Settling Chamber</td> </tr> <tr> <td style="border: none;"><input checked="" type="checkbox"/> Thermal Incinerator</td> <td style="border: none;"><input type="checkbox"/> Flare</td> </tr> <tr> <td style="border: none;"><input type="checkbox"/> Wet Plate Electrostatic Precipitator</td> <td style="border: none;"><input type="checkbox"/> Other (describe _____)</td> </tr> <tr> <td style="border: none;"></td> <td style="border: none;"><input type="checkbox"/> Dry Plate Electrostatic Precipitator</td> </tr> </table>			<input type="checkbox"/> Baghouse/Fabric Filter	<input type="checkbox"/> Venturi Scrubber	<input type="checkbox"/> Multiclone	<input type="checkbox"/> Packed Tower Scrubber	<input type="checkbox"/> Carbon Bed Adsorber	<input type="checkbox"/> Single Cyclone	<input type="checkbox"/> Carbon Drum(s)	<input type="checkbox"/> Cyclone Bank	<input type="checkbox"/> Other Wet Scrubber	<input type="checkbox"/> Condenser	<input type="checkbox"/> Catalytic Incinerator	<input type="checkbox"/> Settling Chamber	<input checked="" type="checkbox"/> Thermal Incinerator	<input type="checkbox"/> Flare	<input type="checkbox"/> Wet Plate Electrostatic Precipitator	<input type="checkbox"/> Other (describe _____)		<input type="checkbox"/> Dry Plate Electrostatic Precipitator
<input type="checkbox"/> Baghouse/Fabric Filter	<input type="checkbox"/> Venturi Scrubber																			
<input type="checkbox"/> Multiclone	<input type="checkbox"/> Packed Tower Scrubber																			
<input type="checkbox"/> Carbon Bed Adsorber	<input type="checkbox"/> Single Cyclone																			
<input type="checkbox"/> Carbon Drum(s)	<input type="checkbox"/> Cyclone Bank																			
<input type="checkbox"/> Other Wet Scrubber	<input type="checkbox"/> Condenser																			
<input type="checkbox"/> Catalytic Incinerator	<input type="checkbox"/> Settling Chamber																			
<input checked="" type="checkbox"/> Thermal Incinerator	<input type="checkbox"/> Flare																			
<input type="checkbox"/> Wet Plate Electrostatic Precipitator	<input type="checkbox"/> Other (describe _____)																			
	<input type="checkbox"/> Dry Plate Electrostatic Precipitator																			
List the pollutants for which this device is intended to control and the capture and control efficiencies.																				
Pollutant	Capture Efficiency	Control Efficiency																		
Volatile Organic Compounds/ Organic Hazardous Air Pollutants		98% typical																		
Explain the characteristic design parameters of this control device (flow rates, pressure drops, number of bags, size, temperatures, etc.).																				
<p style="margin-left: 40px;">Design flow rate = 2,500 scfm Static pressure in combustion chamber at design condition = less than atmospheric Minimum operating combustion chamber temperature = 1,400 deg. F</p>																				
Is this device subject to the CAM requirements of 40 C.F.R. 64? <input checked="" type="checkbox"/> Yes <input type="checkbox"/> No																				
If Yes, Complete ATTACHMENT H																				
If No, Provide justification.																				
Describe the parameters monitored and/or methods used to indicate performance of this control device.																				
See current Title V permit																				

ATTACHMENT G - Air Pollution Control Device Form		
Control device ID number: CLB2VGAC	List all emission units associated with this control device. CLB2VE	
Manufacturer: Carbon Filtration Systems, Inc.	Model number: Model VS-2000	Installation date: 2022
Type of Air Pollution Control Device: <div style="display: flex; justify-content: space-between;"> <div style="width: 45%;"> <input type="checkbox"/> Baghouse/Fabric Filter <input type="checkbox"/> Multiclone <input checked="" type="checkbox"/> Carbon Bed Adsorber <input type="checkbox"/> Carbon Drum(s) <input type="checkbox"/> Other Wet Scrubber <input type="checkbox"/> Catalytic Incinerator <input type="checkbox"/> Thermal Incinerator <input type="checkbox"/> Wet Plate Electrostatic Precipitator </div> <div style="width: 45%;"> <input type="checkbox"/> Venturi Scrubber <input type="checkbox"/> Packed Tower Scrubber <input type="checkbox"/> Single Cyclone <input type="checkbox"/> Cyclone Bank <input type="checkbox"/> Condenser <input type="checkbox"/> Settling Chamber <input type="checkbox"/> Flare <input type="checkbox"/> Other (describe) <input type="checkbox"/> Dry Plate Electrostatic Precipitator </div> </div>		
List the pollutants for which this device is intended to control and the capture and control efficiencies.		
Pollutant	Capture Efficiency	Control Efficiency
Volatile Organic Compounds/ Organic Hazardous Air Pollutants		95% typical
Explain the characteristic design parameters of this control device (flow rates, pressure drops, number of bags, size, temperatures, etc.). <p style="margin-left: 40px;">Design flow rate = 796 ACFM @100°F, 50 psia Pressure drop across unit = 4-5 inches of w.c. per vessel Maximum temperature 140 °F</p>		
Is this device subject to the CAM requirements of 40 C.F.R. 64? ___ Yes <input checked="" type="checkbox"/> No If Yes, Complete ATTACHMENT H If No, Provide justification. Pre-control device total HAP and individual HAP emissions are less than major source thresholds (40 C.F.R. §64.2(a)(3)).		
Describe the parameters monitored and/or methods used to indicate performance of this control device. <p style="margin-left: 40px;">See Attachment J, New Applicable Requirements. This equipment has not been installed yet. It was added to R13-2840E, which was issued on May 11, 2022.</p>		

ATTACHMENT G - Air Pollution Control Device Form		
Control device ID number: MIGCS CO	List all emission units associated with this control device. MIGCS	
Manufacturer: Anguil Environmental Systems, Inc.	Model number: Model 25	Installation date: 2017
Type of Air Pollution Control Device:		
<input type="checkbox"/> Baghouse/Fabric Filter	<input type="checkbox"/> Venturi Scrubber	
<input type="checkbox"/> Multiclone	<input type="checkbox"/> Packed Tower Scrubber	
<input type="checkbox"/> Carbon Bed Adsorber	<input type="checkbox"/> Single Cyclone	
<input type="checkbox"/> Carbon Drum(s)	<input type="checkbox"/> Cyclone Bank	
<input type="checkbox"/> Other Wet Scrubber	<input type="checkbox"/> Condenser	
<input checked="" type="checkbox"/> Catalytic Incinerator	<input type="checkbox"/> Settling Chamber	
<input type="checkbox"/> Thermal Incinerator	<input type="checkbox"/> Flare	
_____	<input type="checkbox"/> Other (Describe: _____)	
<input type="checkbox"/> Wet Plate Electrostatic Precipitator	<input type="checkbox"/> Dry Plate Electrostatic Precipitator	
List the pollutants for which this device is intended to control and the capture and control efficiencies.		
Pollutant	Capture Efficiency	Control Efficiency
Volatile Organic Compounds/ Organic Hazardous Air Pollutants		95%
Explain the characteristic design parameters of this control device (flow rates, pressure drops, number of bags, size, temperatures, etc.).		
Maximum design flow rate = 1,000 scfm Temperature catalyst bed inlet/outlet = 600-1200 °F Maximum temperature exhaust stream = 180°F		
Is this device subject to the CAM requirements of 40 C.F.R. 64? <input type="checkbox"/> Yes <input checked="" type="checkbox"/> No		
If Yes, Complete ATTACHMENT H		
If No, Provide justification.		
Uncontrolled emissions are not over 100 percent of the major source threshold amount (40 C.F.R. §64.2(a)(3)).		
Describe the parameters monitored and/or methods used to indicate performance of this control device.		
See current Title V permit.		

ATTACHMENT G - Air Pollution Control Device Form		
Control device ID number: MIGCS GAC	List all emission units associated with this control device. MIGCS	
Manufacturer: Carbon/Air	Model number: Model GPC 3H	Installation date: Has not been installed
Type of Air Pollution Control Device: <div style="display: flex; justify-content: space-between;"> <div style="width: 45%;"> <p><input type="checkbox"/> Baghouse/Fabric Filter</p> <p><input type="checkbox"/> Multiclone</p> <p><input checked="" type="checkbox"/> Carbon Bed Adsorber</p> <p><input type="checkbox"/> Carbon Drum(s)</p> <p><input type="checkbox"/> Other Wet Scrubber</p> <p><input type="checkbox"/> Catalytic Incinerator</p> <p><input type="checkbox"/> Thermal Incinerator</p> <p><input type="checkbox"/> Wet Plate Electrostatic Precipitator</p> </div> <div style="width: 45%;"> <p><input type="checkbox"/> Venturi Scrubber</p> <p><input type="checkbox"/> Packed Tower Scrubber</p> <p><input type="checkbox"/> Single Cyclone</p> <p><input type="checkbox"/> Cyclone Bank</p> <p><input type="checkbox"/> Condenser</p> <p><input type="checkbox"/> Settling Chamber</p> <p><input type="checkbox"/> Flare</p> <p><input type="checkbox"/> Other (describe: _____)</p> <p><input type="checkbox"/> Dry Plate Electrostatic Precipitator</p> </div> </div>		
List the pollutants for which this device is intended to control and the capture and control efficiencies.		
Pollutant	Capture Efficiency	Control Efficiency
Volatile Organic Compounds/ Organic Hazardous Air Pollutants		95% typical
Explain the characteristic design parameters of this control device (flow rates, pressure drops, number of bags, size, temperatures, etc.). <p style="margin-left: 40px;">Design flow rate = 500 acfm @90 °F, 50 psia Pressure Drop across unit = upwards of 25 inches of w.c. per vessel</p>		
Is this device subject to the CAM requirements of 40 C.F.R. 64? <input type="checkbox"/> Yes <input checked="" type="checkbox"/> No If Yes, Complete ATTACHMENT H If No, Provide justification. <p style="margin-left: 40px;">Uncontrolled emissions are not over 100 percent of the major source threshold amount (40 C.F.R. §64.2(a)(3)).</p>		
Describe the parameters monitored and/or methods used to indicate performance of this control device. <p style="margin-left: 40px;">See current Title V permit.</p>		

ATTACHMENT G - Air Pollution Control Device Form		
Control device ID number: A42PBS	List all emission units associated with this control device. A42INC	
Manufacturer: Verantis (Ceilcote Air Pollution Control)	Model number: None specified	Installation date: July 2011
Type of Air Pollution Control Device:		
<input type="checkbox"/> Baghouse/Fabric Filter	<input type="checkbox"/> Venturi Scrubber	<input type="checkbox"/> Multiclone
<input type="checkbox"/> Carbon Bed Adsorber	<input checked="" type="checkbox"/> Packed Tower Scrubber	
<input type="checkbox"/> Carbon Drum(s)	<input type="checkbox"/> Single Cyclone	
<input type="checkbox"/> Catalytic Incinerator	<input type="checkbox"/> Other Wet Scrubber	
<input type="checkbox"/> Thermal Incinerator	<input type="checkbox"/> Cyclone Bank	
<input type="checkbox"/> Wet Plate Electrostatic Precipitator	<input type="checkbox"/> Condenser	
	<input type="checkbox"/> Settling Chamber	
	<input type="checkbox"/> Flare	
	<input type="checkbox"/> Other (describe)	
	<input type="checkbox"/> Dry Plate Electrostatic Precipitator	
List the pollutants for which this device is intended to control and the capture and control efficiencies.		
Pollutant	Capture Efficiency	Control Efficiency
Hydrochloric Acid		99.5%
Explain the characteristic design parameters of this control device (flow rates, pressure drops, number of bags, size, temperatures, etc.).		
Design flow rate = 2,500 scfm (4,924 acfm) Scrubbing fluid = 20% NaOH Packing depth = 10 feet Scrubber tower diameter = 36 in Scrubber tower height = 18 ft 7 in		
Is this device subject to the CAM requirements of 40 C.F.R. 64? <input checked="" type="checkbox"/> Yes <input type="checkbox"/> No		
If Yes, Complete ATTACHMENT H		
If No, Provide justification.		
Describe the parameters monitored and/or methods used to indicate performance of this control device.		
See current Title V permit		

ATTACHMENT G - Air Pollution Control Device Form

Control device ID number: MI2CO	List all emission units associated with this control device. MI2VE
---	--

Manufacturer: Anguil	Model number:	Installation date: 2014
--------------------------------	----------------------	-----------------------------------

Type of Air Pollution Control Device:

<input type="checkbox"/> Baghouse/Fabric Filter	<input type="checkbox"/> Venturi Scrubber	<input type="checkbox"/> Multiclone
<input type="checkbox"/> Carbon Bed Adsorber	<input type="checkbox"/> Packed Tower Scrubber	<input type="checkbox"/> Single Cyclone
<input type="checkbox"/> Carbon Drum(s)	<input type="checkbox"/> Other Wet Scrubber	<input type="checkbox"/> Cyclone Bank
<input checked="" type="checkbox"/> Catalytic Incinerator	<input type="checkbox"/> Condenser	<input type="checkbox"/> Settling Chamber
<input type="checkbox"/> Thermal Incinerator	<input type="checkbox"/> Flare	<input type="checkbox"/> Other (describe) _____
<input type="checkbox"/> Wet Plate Electrostatic Precipitator	<input type="checkbox"/> Dry Plate Electrostatic Precipitator	

List the pollutants for which this device is intended to control and the capture and control efficiencies.

Pollutant	Capture Efficiency	Control Efficiency
VOC	100%	95%

Explain the characteristic design parameters of this control device (flow rates, pressure drops, number of bags, size, temperatures, etc.).

1,000 scfm VOC loading, Catalyst bed outlet temperature range 600-1,200 °F. Permit requires combustion chamber temperature of at least 650°F.

Is this device subject to the CAM requirements of 40 C.F.R. 64? Yes No

If Yes, **Complete ATTACHMENT H**

If No, **Provide justification.** Pre-control device emissions are less than major source thresholds. Refer to significant modification fact sheet of November 6, 2015.

Describe the parameters monitored and/or methods used to indicate performance of this control device.

Refer to current Title V permit.

ATTACHMENT G - Air Pollution Control Device Form

Control device ID number: C-1087-1	List all emission units associated with this control device. Bin 8701
--	---

Manufacturer: Mikropul	Model number: 16S -8	Installation date:
----------------------------------	--------------------------------	---------------------------

Type of Air Pollution Control Device:

<input checked="" type="checkbox"/> Baghouse/Fabric Filter	<input type="checkbox"/> Venturi Scrubber	<input type="checkbox"/> Multiclone
<input type="checkbox"/> Carbon Bed Adsorber	<input type="checkbox"/> Packed Tower Scrubber	<input type="checkbox"/> Single Cyclone
<input type="checkbox"/> Carbon Drum(s)	<input type="checkbox"/> Other Wet Scrubber	<input type="checkbox"/> Cyclone Bank
<input type="checkbox"/> Catalytic Incinerator	<input type="checkbox"/> Condenser	<input type="checkbox"/> Settling Chamber
<input type="checkbox"/> Thermal Incinerator	<input type="checkbox"/> Flare	<input type="checkbox"/> Other (describe) _____
<input type="checkbox"/> Wet Plate Electrostatic Precipitator	<input type="checkbox"/> Dry Plate Electrostatic Precipitator	

List the pollutants for which this device is intended to control and the capture and control efficiencies.

Pollutant	Capture Efficiency	Control Efficiency
Particulate Matter		99% estimated

Explain the characteristic design parameters of this control device (flow rates, pressure drops, number of bags, size, temperatures, etc.).

Atmospheric Bin Vent Filter.
 Area = 151 ft²
 Inlet gas 715 acfm @ 80 F.

Is this device subject to the CAM requirements of 40 C.F.R. 64? Yes No

If Yes, **Complete ATTACHMENT H**

If No, **Provide justification.** Pre-control device particulate emissions are less than 5 tons/yr. The process specific equipment unit has potential pre-control device emissions of particulate matter less than the Title V major source threshold level.

Describe the parameters monitored and/or methods used to indicate performance of this control device.

See current Title V permit requirements.

ATTACHMENT G - Air Pollution Control Device Form

Control device ID number: C8105	List all emission units associated with this control device. 8101 Refining Still	
Manufacturer: N/A – UCC Designed	Model number: N/A	Installation date: N/A

Type of Air Pollution Control Device:

<input type="checkbox"/> Baghouse/Fabric Filter	<input type="checkbox"/> Venturi Scrubber	<input type="checkbox"/> Multiclone
<input type="checkbox"/> Carbon Bed Adsorber	<input type="checkbox"/> Packed Tower Scrubber	<input type="checkbox"/> Single Cyclone
<input type="checkbox"/> Carbon Drum(s)	<input type="checkbox"/> Other Wet Scrubber	<input type="checkbox"/> Cyclone Bank
<input type="checkbox"/> Catalytic Incinerator	<input checked="" type="checkbox"/> Condenser	<input type="checkbox"/> Settling Chamber
<input type="checkbox"/> Thermal Incinerator	<input type="checkbox"/> Flare	<input type="checkbox"/> Other (describe) _____
<input type="checkbox"/> Wet Plate Electrostatic Precipitator	<input type="checkbox"/> Dry Plate Electrostatic Precipitator	

List the pollutants for which this device is intended to control and the capture and control efficiencies.

Pollutant	Capture Efficiency	Control Efficiency
Volatile Organic Compounds/Hazardous Air Pollutants	100%	90% estimated

Explain the characteristic design parameters of this control device (flow rates, pressure drops, number of bags, size, temperatures, etc.).

Coolant flow rate: 1,000 gal/min
 100 °C inlet temperature - 30 °C outlet temperature
 Condenser surface area: 260 ft²

Is this device subject to the CAM requirements of 40 C.F.R. 64? Yes No

If Yes, Complete ATTACHMENT H

If No, Provide justification. Pre-control device volatile organic compound emission are approximately 18 tons/yr. The process specific equipment unit has potential pre-control device emissions of volatile organic compounds and hazardous air pollutants are less than the Title V major source threshold level.

Describe the parameters monitored and/or methods used to indicate performance of this control device.

ATTACHMENT G - Air Pollution Control Device Form

Control device ID number: C8110	List all emission units associated with this control device. Tanks 8310, 8340, 8528, 8540 Reactors 8400, 8500
---	--

Manufacturer: N/A – UCC Designed	Model number: N/A	Installation date: 1976
--	-----------------------------	-----------------------------------

Type of Air Pollution Control Device:

<input type="checkbox"/> Baghouse/Fabric Filter	<input type="checkbox"/> Venturi Scrubber	<input type="checkbox"/> Multiclone
<input type="checkbox"/> Carbon Bed Adsorber	<input type="checkbox"/> Packed Tower Scrubber	<input type="checkbox"/> Single Cyclone
<input type="checkbox"/> Carbon Drum(s)	<input checked="" type="checkbox"/> Other Wet Scrubber	<input type="checkbox"/> Cyclone Bank
<input type="checkbox"/> Catalytic Incinerator	<input type="checkbox"/> Condenser	<input type="checkbox"/> Settling Chamber
<input type="checkbox"/> Thermal Incinerator	<input type="checkbox"/> Flare	<input type="checkbox"/> Other (describe) _____
<input type="checkbox"/> Wet Plate Electrostatic Precipitator	<input type="checkbox"/> Dry Plate Electrostatic Precipitator	

List the pollutants for which this device is intended to control and the capture and control efficiencies.

Pollutant	Capture Efficiency	Control Efficiency
Volatile Organic Compounds	100%	90%

Explain the characteristic design parameters of this control device (flow rates, pressure drops, number of bags, size, temperatures, etc.).

Caustic Scrubber
 2 wt.% aqueous NaOH

Is this device subject to the CAM requirements of 40 C.F.R. 64? Yes No

If Yes, **Complete ATTACHMENT H**

If No, **Provide justification.** Pre-control device volatile organic compound emissions are approximately 8 tons/yr. The process specific equipment unit has potential pre-control device emissions of volatile organic compound less than the Title V major source threshold level.

Describe the parameters monitored and/or methods used to indicate performance of this control device.

See current Title V Permit requirements.

ATTACHMENT G - Air Pollution Control Device Form

Control device ID number: C8130	List all emission units associated with this control device. Tanks 8340, 8353, 8363, 8370, 8382 Reactors 8500, 8600, 8617 Caustic Scrubber C8110	
Manufacturer: N/A – Custom designed by UCC	Model number: N/A	Installation date: 1976

Type of Air Pollution Control Device:

<input type="checkbox"/> Baghouse/Fabric Filter	<input type="checkbox"/> Venturi Scrubber	<input type="checkbox"/> Multiclone
<input type="checkbox"/> Carbon Bed Adsorber	<input checked="" type="checkbox"/> Packed Tower Scrubber	<input type="checkbox"/> Single Cyclone
<input type="checkbox"/> Carbon Drum(s)	<input type="checkbox"/> Other Wet Scrubber	<input type="checkbox"/> Cyclone Bank
<input type="checkbox"/> Catalytic Incinerator	<input type="checkbox"/> Condenser	<input type="checkbox"/> Settling Chamber
<input type="checkbox"/> Thermal Incinerator	<input type="checkbox"/> Flare	<input type="checkbox"/> Other (describe) _____
<input type="checkbox"/> Wet Plate Electrostatic Precipitator		<input type="checkbox"/> Dry Plate Electrostatic Precipitator

List the pollutants for which this device is intended to control and the capture and control efficiencies.

Pollutant	Capture Efficiency	Control Efficiency
Volatile Organic Compounds	100%	90% estimated

Explain the characteristic design parameters of this control device (flow rates, pressure drops, number of bags, size, temperatures, etc.).

Water Scrubber

Is this device subject to the CAM requirements of 40 C.F.R. 64? Yes No

If Yes, **Complete ATTACHMENT H**

If No, **Provide justification.** Pre-control device volatile organic compound emissions are approximately 18 tons/yr. The process specific equipment unit has potential pre-control device emissions of volatile organic compounds less than the Title V major source threshold level.

Describe the parameters monitored and/or methods used to indicate performance of this control device.

See current Title V permit requirements.

Attachment I

New Applicable Requirements

Attachment I

New Applicable Requirements

Minor Modification (submitted February 2022)

Description of Changes - No changes to facility. This revision is being submitted to reassign storage tanks previously subject to the MON MACT (Subpart FFFF) to the Polyether Polyols MACT (Subpart PPP) because of a recent predominant use determination per the storage vessel ownership determination procedure in 40 C.F.R. §63.1420(f). This change affects only condition number 5.1.13 to remove such tanks. As these tanks are considered Group 2 storage vessels per Subpart PPP, there are no applicable emissions or work standards. Only recordkeeping of dimensions and capacity are required. Current Title V condition 5.1.7 incorporates such requirement by reference.

Revised MON and PPP NOCS was submitted on February 28, 2022 to document the changes.

Proposed permit language with strike-throughs indicating removal:

5.1.13. **MON MACT.** The permittee shall comply with the following general requirements for emission limits, work practice standards and compliance requirements as specified by §63.2450.

- The Solvent Recovery Column (Eq. Id. 8101), Group 2 Continuous Process Vent, must be operated with a total resource effectiveness (TRE) index greater than 5.0.
- Rail car and tank truck loading racks used to load organic liquids containing hazardous air pollutants shall be operated as Group 2 transfer operations as defined by the MON Rule. (Rack IDs: L-1001, L-1003, L-1004 and L-1005).
- The following storage vessels shall be operated as Group 2 as defined by the MON Rule.

(Storage Vessel IDs: T8310, T8320, T8321, ~~T8322, T8323~~, T8324, ~~T8331, T8334, T8343, T8344~~, T8345, T8346, T8351, ~~T8353~~, T8355, T8356, T8360, T8361, T8362, ~~T8363~~, T8364, T8365, T8366, T8373, T8375, T8376, ~~T8380, T8381~~, T8382, ~~T8383, T8390, T8391, T8392, T8393, T8420~~, and T8817.

[45CSR34, 40 C.F.R. §63.2450]

Minor Modification (submitted February 2022)

R13 permit revision to R13-2840D, issued as R13-2840E on which covers the installation of a new Chlorobenzene Area 2 remediation site and uses existing control devices and has an alternative control to be used if existing control is off line. Language below reflects the issued R13 permit and is numbered to coincide with the current Title V nomenclature.

Proposed Permit Language

11.0 Source-Specific Requirements for [Groundwater/Soil Remediation Process, Emission Point ID (SVE1, SVE2, [SVE3](#), MI2VE2)]

11.1. Limitations and Standards

11.1.18. Emissions of regulated pollutants from the Chlorobenzene Area 2 Vapor Extraction System (CLB2VE) shall be routed to the Thermal Oxidizer (A42INC) except during Thermal Oxidizer downtime.

11.1.18.1. During Thermal Oxidizer (A42INC) downtime due to planned maintenance or unplanned outages, emissions of regulated pollutants from the Chlorobenzene Area 2 Vapor Extraction System (CLB2VE) shall be routed to the vapor phase granular activated carbon vessels (CLB2VGAC). Downtime of the Thermal Oxidizer shall not exceed 3,571 hours per year.

[45CSR13, R13-2840, 4.1.12]

11.1.19. Pollutant emissions vented from the CLB2VGAC shall not exceed the following:

<u>Pollutant</u>	<u>lb/hr</u>	<u>tpy</u>
<u>Ethylbenzene</u>	<u>0.01</u>	<u>0.01</u>
<u>Xylene</u>	<u>0.01</u>	<u>0.01</u>
<u>Naphthalene</u>	<u>0.08</u>	<u>0.14</u>
<u>Total VOC/HAPs</u>	<u>0.10</u>	<u>0.16</u>

[45CSR13, R13-2840, 4.1.13]

11.1.20. The CLB2VE closed-vent system shall be designed to operate with no detectable organic emissions using the procedure specified in 40 C.F.R. §63.695(c)(2) and monitoring as specified in 40 C.F.R. §63.7928(b)(2).

[45CSR13, R13-2840, 4.1.14; 45CSR34; 40 C.F.R. §63.7925(c)]

11.1.21. Carbon replacement for the vapor phase granular activated carbon vessels (CLB2VGAC) shall be performed at the frequency determined during the initial design evaluation (see 11.2.5) or when monitoring indicates breakthrough has occurred.

[45CSR13, R13-2840, 4.1.15; 45CSR34; 40 C.F.R. §63.7925(h)(2)(i)]

11.2. Testing Requirements

11.2.5. A design evaluation shall be performed on the Chlorobenzene Area 2 vapor extractive system (CLB2VE) in accordance with 40 C.F.R. §63.693(d)(2)(ii)(B) within 180 days of startup of operations. The design evaluation shall assess the CLB2VE vent stream composition, constituent concentrations, flow rate, relative humidity, and temperature. The evaluation shall establish the design exhaust vent stream organic compound concentration, carbon bed capacity, activated carbon type and working capacity, and design carbon replacement interval based on the total carbon working capacity of the control device and emission point operating schedule.

[45CSR13, R13-2840, 4.2.4; 45CSR34; 40 C.F.R. §63.7940(a)]

11.3. Monitoring and Recordkeeping Requirements

11.3.1. (Revision to citation only. See below.)

[45CSR13, Permit Number R13-2840, Condition 4.3.1, Emission Point ID (SVE1 and SVE3)]

11.3.2. (Revision to citation only. See below.)

[45CSR13, Permit Number R13-2840, Condition 4.3.2, Emission Point ID (SVE1 [and SVE3](#))]

11.3.3. (Revision to citation only. See below.)

[45CSR13, Permit Number R13-2840, Condition 4.3.3, Emission Point ID (SVE1 [and SVE3](#))]

11.3.9. To show compliance with the emission limits in 11.1.19, the permittee shall keep a monthly record of hours that the CLB2VE vapors are routed to the two vapor granular carbon vessels CLB2VGAC. These monthly records shall be used to calculate a twelve month rolling total which shall not exceed the hour limit in 11.1.18.1.

[45CSR13, R13-2840, 4.3.7]

11.3.10. To demonstrate compliance with the requirement of 11.1.21, the concentration of organic compounds in the exhaust vent stream of CLB2VGAC shall be monitored according to the requirements in 40 C.F.R. §63.693(d)(4)(iii)(A).

[45CSR13, R13-2840, 4.3.8; 45CSR34; 40 C.F.R. §63.7927(c)]

11.3.11. The permittee shall maintain the following records relating to the CLB2VGAC.

11.3.11.1. Copy of equipment design and installation.

11.3.11.2. Completed maintenance and calibrations.

11.3.11.3. Copy of the site-specific monitoring plan. The plan may refer to the manufacturer's operation and maintenance manual or other documents for procedures covering operation, maintenance, calibrations and inspections, and startup and shutdown, and malfunctions.

11.3.11.4. Copies of all performance tests and design evaluations.

11.3.11.5. Records demonstrating compliance with emission limitations, work practice standards, and operation and maintenance requirements.

[45CSR13, R13-2840, 4.3.9; 45CSR34; 40 C.F.R. §63.7952(c)]

11.4. Reporting Requirements

11.4.2. An initial notification of compliance status will be submitted for Chlorobenzene Area 2 vapor extraction system to certify the closed vent system was installed and inspected according to the requirements of 40 C.F.R. §63.695. The results of the design evaluation and supporting documentation (See 11.2.5) will be included with the certification.

[45CSR13, R13-2840, 4.4.2; 45CSR34; 40 C.F.R. §63.7950(e)(1)]